

Product Specification

SPECIFICATION FOR APPROVAL

- () Preliminary Specification
() Final Specification

Title	15.0" XGA TFT LCD
-------	-------------------

BUYER	
MODEL	

SUPPLIER	LG.Philips LCD Co., Ltd.
MODEL	LP150X1-F2IB
Safety Application Model	LP150X1

SIGNATURE	DATE
/	_____
/	_____
/	_____

Please return 1 copy for your confirmation with your signature and comments.

APPROVED BY	DATE
S.H.Kang / G.Manager	_____
REVIEWED BY S.C.Yoon / Manager B.H.Koo / Manager	_____
PREPARED BY B.K.JUNG / Engineer J.S.JANG / Engineer	_____

Product Engineering Dept.
LG.Philips LCD Co., Ltd.

CONTENTS

NO.	ITEM	Page
-	COVER	1
-	CONTENTS	2
-	RECORD OF REVISIONS	3
1	GENERAL DESCRIPTION	4
2	ABSOLUTE MAXIMUM RATINGS	5
3	ELECTRICAL SPECIFICATIONS	6
3-1	ELECTRICAL CHARACTERISTICS	6
3-2	INTERFACE CONNECTIONS	7
3-3	SIGNAL TIMING SPECIFICATIONS	9
3-4	SIGNAL TIMING WAVEFORMS	10
3-5	COLOR INPUT DATA REFERENCE	11
3-6	POWER SEQUENCE	12
4	OPTICAL SPECIFICATIONS	13
5	MECHANICAL CHARACTERISTICS	14
6	RELIABILITY	18
7	INTERNATIONAL STANDARDS	19
7-1	SAFETY	19
7-2	EMC	19
8	PACKING	20
8-1	DESIGNATION OF LOT MARK	20
8-2	PACKING FORM	20
9	PRECAUTIONS	21
	APPENDIX	
A-1	OPTICAL CHARACTERISTIC MEASUREMENT EQUIPMENT AND METHOD	23
A-2	LUMINANCE	23
A-3	RESPONSE TIME	23
A-4	VIEWING ANGLE	24

1. General Description

The LP150X1-F2IB is a Color Active Matrix Liquid Crystal Display with an integral Cold Cathode Fluorescent Tube(CCFL) back light system. The matrix employs a-Si Thin Film Transistor as the active element. It is a transmissive type display operating in the normally white mode. This TFT-LCD has a 15.0 inch diagonally measured active display area with XGA resolution(768 vertical by 1024 horizontal pixel array). Each pixel is divided into Red, Green and Blue sub-pixels or dots which are arranged in vertical stripes. Gray scale of the brightness of the sub-pixel color is determined with a 6-bit gray scale signal for each dot, thus, presenting a palette of more than 262,144 colors.

The LP150X1- F2IB has been designed to apply the interface method that enables low power, high speed low EMI. Flat Link must be used as a LVDS(Low Voltage Differential Signaling) chip.

The LP150X1- F2IB is intended to support applications where thin thickness, low power are critical factors and graphic displays are important. In combination with the vertical arrangement of the sub-pixels, the LP150X1- F2IB characteristics provide an excellent flat panel display for office automation products.

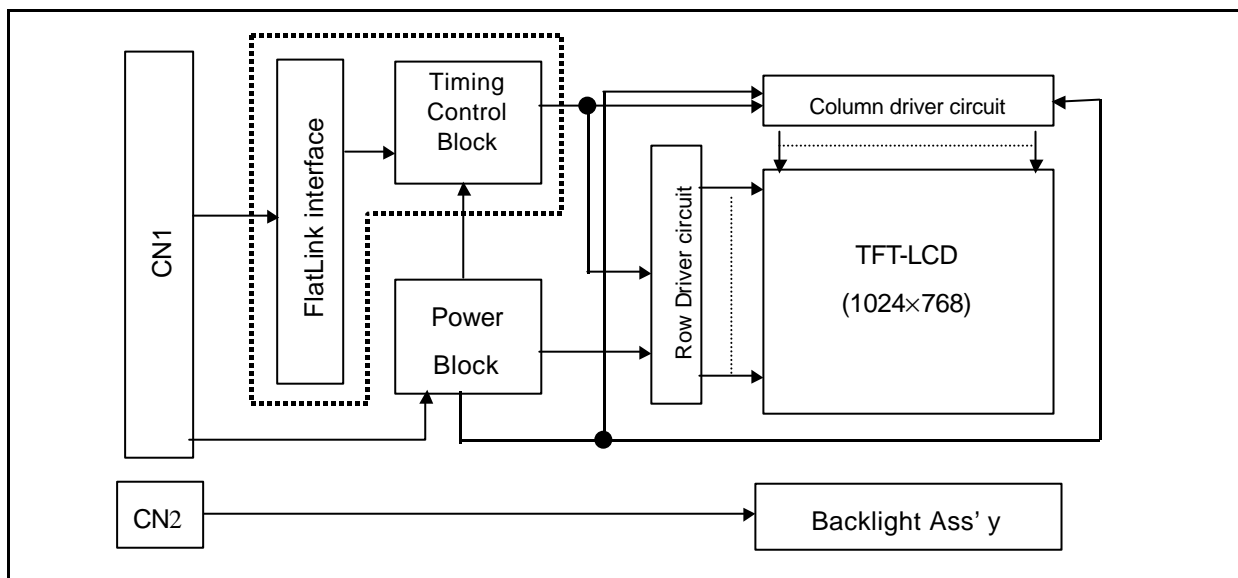

General Features

Active screen size	15.0 inches (38.1cm) diagonal
Outline dimensions	315.5(H) × 242.3(V) × 7.0(D) mm (typ)
Pixel pitch	0.297 mm × 0.297 mm
Pixel format	1024 horiz. By 768 vert. pixels
	RGB stripe arrangement
Color depth	6bit, 262,144 colors
Luminance,White	150 cd/m ² (typ) (center 1 point)
Power Consumption	Total 4.93Watt(typ) (1.15Watt @ VCC=3.3, 3.78Watt@150nit,Lamp)
Weight	685g (typ)
Display operating mode	Transmissive mode, normally white
Surface treatments	Hard coating(3H), Anti-glare treatment of the front polarizer

Product Specification

2. Absolute Maximum Ratings

The following are maximum values which, if exceeded, may cause faulty operation or damage to the unit.

Table 1 ABSOLUTE MAXIMUM RATINGS

Parameter	Symbol	Values		Units	Notes
		Min.	Max.		
Power Input Voltage	V_{CC}	-0.3	+3.6	Vdc	at 25 1,2
Operating Temperature	T_{OP}	0	+50		
Storage Temperature	T_{ST}	-20	+60		

Note: 1. Temperature at 5mm above display center of LCD Module.

$T_a = 40$: 90%RH Max

$T_a > 40$: Absolute Humidity shall be less than $T_a = 40$ 90%RH .

These shall be no dew condensation.

2. Humidity Min. 5%RH, Max. 90%RH

Product Specification

3. Electrical Specifications

3-1. Electrical Characteristics

The LP150X1-F2IB requires two power inputs. One is employed to power the LCD electronics and to drive the TFT array and liquid crystal. The second input which powers the CCFL, is typically generated by an inverter. The inverter is an external unit to the LCD.

Table 2 ELECTRICAL CHARACTERISTICS:

Parameter	Symbol	Values			Units	Note 2
		Min.	Typ.	Max.		
MODULE:						
Power Supply Input Voltage	V_{CC}	3.0	3.3	3.6	Vdc	
Power Supply Input Current	I_{CC}	-	0.350	0.400	A	1
Differential Impedance	Z_m	90	100	110	ohm	2
Power Consumption	P_c	-	1.15	2.2	Watts	1
Rush current	I_{RUSH}	-	1.5	1.8	A	3
LAMP						
Operating Voltage	V_L	600(7mA)	630(6.0mA)	740(3mA)	V_{RMS}	4
Operating Current	I_L	3.0	6.0	7.0	mA	
Established Starting Voltage						5
at 25		-	-	1100	V_{RMS}	
at 0		-	-	1300	V_{RMS}	
Operating Frequency	F_L	40	60	80	KHz	
Discharge Stabilization Time	T_s	-	-	3	Minutes	5
Power Consumption	P_L	-	3.78	4.2	Watts	7
Life Time		10,000	-	-	Hrs	@6.0mA, 25

Note 1:

The design of the inverter must have specifications for the lamp in LCD Assembly.

The performance of the Lamp in LCM, for example life time or brightness, is extremely influenced by the characteristics of the DC-AC Inverter. So all the parameters of an inverter should be carefully designed so as not to produce too much leakage current from high-voltage output of the inverter.

When you design or order the inverter, please make sure unwanted lighting caused by the mismatch of the lamp and the inverter (no lighting, flicker, etc) never occurs. When you confirm it, the LCD Assembly should be operated in the same condition as installed in your instrument.

Note 2:

1. The specified current and power consumption are under the $V_{CC} = 3.3V$, 25 , $f_v = 60Hz$ condition where white 64 gray pattern is displayed.
2. This impedance value is needed to proper display and measured from LVDS Tx to the mating connector.
3. The duration of rush current is about 20ms.
4. The variance of the voltage is $\pm 10\%$.
5. Let's define the brightness of the lamp after being lighted for 5 minutes as 100%.
 T_s is the time required for the brightness of the center of the lamp to be not less than 95%.
6. The transformer output voltage in the inverter must be high considering the loss of the ballast capacitor in the inverter.
7. The lamp power consumption shown above does not include loss of external inverter.
8. The life time is determined as the time at which brightness of lamp is 50% compared to that of initial value at the typical lamp current

Product Specification

3-2. Interface Connections

Interface chip must be used FlatLink , part No. SN75LVDS84(Transmitter) made by Texas Instrument Inc. or equivalent.

This LCD employs two interface connections, a 20 pin connector is used for the module electronics and the other connector is used for the integral backlight system.

The electronics interface connector is a model FI-SEB20P-HF13 manufactured by JAE. The pin configuration for the connector is shown in the table below.

Table 3 MODULE CONNECTOR PIN CONFIGURATION (LVDS)

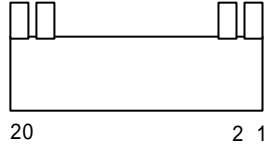
Pin	Symbol	Description	Notes
1	Vcc	Power (3.3V)	1. Interface chips 1.1 LCD : KZ4E038C12 one-chip ASIC including LVDS Receiver 1.2 System : SN75LVDS84 or equivalent * Pin to Pin compatible with THINE LVDS 2. Connector 2.1 LCD : FI-SEB20P-HF13(JAE) or equivalent 2.2 Mating : FI-SEB20S(JAE) or equivalent 2.3 Connector pin arrangement  <p style="text-align: center;">< BOTTOM VIEW</p>
2	Vcc	Power (3.3V)	
3	GND	Ground	
4	GND	Ground	
5	A1M	Differential Signal	
6	A1P	Differential Signal	
7	GND	Ground	
8	A2M	Differential Signal	
9	A2P	Differential Signal	
10	GND	Ground	
11	A3M	Differential Signal	
12	A3P	Differential Signal	
13	GND	Ground	
14	CLKM	Differential Signal	
15	CLKP	Differential Signal	
16	GND	Ground	
17	NC	No Connection	
18	NC	No Connection	
19	GND	Ground	
20	GND	Ground	

The backlight interface connector is a model BHSR-02VS-1, manufactured by JST. The mating connector part number is SM02B-BHSS-1 or equivalent. The pin configuration for the connector is shown in the table below.

Table 4 BACKLIGHT CONNECTOR PIN CONFIGURATION

Pin	Symbol	Description	Notes
1	HV	Lamp power input	1
2	LV	Ground	2

Notes: 1. The input power wire is colored pink. Ground wire color is black.
 2. The lamp ground should be common with GND.

Product Specification

Table 5 REQUIRED SIGNAL ASSIGNMENT FOR FlatLink Transmitter

Pin #	Pin Name	Require Signals	Pin #	Pin Name	Require Signals
1	D4	R4	48	D3	R3
2	Vcc	Vcc	47	D2	R2
3	D5	R5	46	GND	GND
4	D6	G0	45	D1	R1
5	GND	GND	44	D0	R0
6	D7	G1	43	NC	NC
7	D8	G2	42	LVDS GND	LVDS GND
8	Vcc	Vcc	41	Y0M	A0M
9	D9	G3	40	Y0P	A0P
10	D10	G4	39	Y1M	A1M
11	GND	GND	38	Y1P	A1P
12	D11	G5	37	LVDS Vcc	LVDS Vcc
13	D12	B0	36	LVDS GND	LVDS GND
14	NC	NC	35	Y2M	A2M
15	D13	B1	34	Y2P	A2P
16	D14	B2	33	CLKOUTM	CLKM
17	GND	GND	32	CLKOUTP	CLKP
18	D15	B3	31	LVDS GND	LVDS GND
19	D16	B4	30	PLLGND	PLL GND
20	D17	B5	29	PLLVcc	PLL Vcc
21	Vcc	Vcc	28	PLLGND	PLL GND
22	D18	HSYNC	27	$\overline{\text{SHDN}}$	$\overline{\text{SHDN}}$
23	D19	VSYNC	26	CLKIN	Dclk
24	GND	GND	25	D20	DE(Data Enable)

Notes : Refer to LVDS Transmitter Data Sheet for detail descriptions.

Product Specification

3-3. Signal Timing Specifications

This is the signal timing required at the input of the LVDS Transmitter. All of the interface signal timing should be satisfied with the following specifications for it's proper operation.

Table 6 Timing Table

	ITEM	SYMBOL	MIN.	TYP.	MAX.	UNIT	NOTE
Dclk	Period	t_{CLK}	15.2	15.4	16.6	ns	65MHz
Hsync	Period	t_{HP}	1280	1344	1364	t_{CLK}	
	Width-Active	t_{WH}	120	136	146		
Vsync	Period	t_{VP}	801	806	812	t_{HP}	
	Frequency	f_v		60	-	Hz	
	Width-Active	t_{WV}	1	6	24	t_{HP}	
DE (Data Enable)	Horizontal Back Porch	t_{HBP}	65	160	-	t_{CLK}	
	Horizontal Front Porch	t_{HFP}	20	24	45		
	Vertical Back Porch	t_{VBP}	2	29	-	t_{HP}	
	Vertical Front Porch	t_{VFP}	1	3	-		

Product Specification

3-4. Signal Timing Waveforms

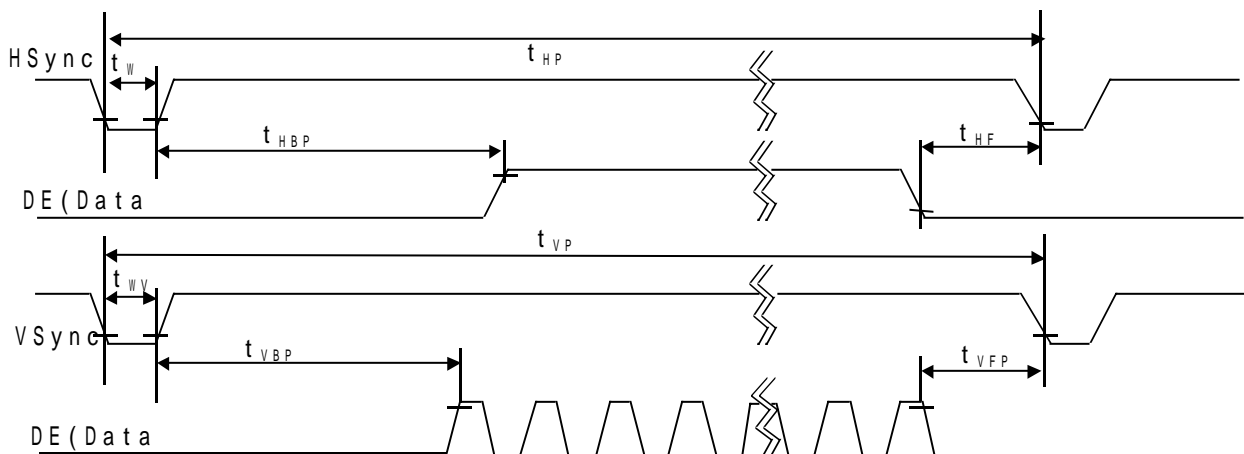
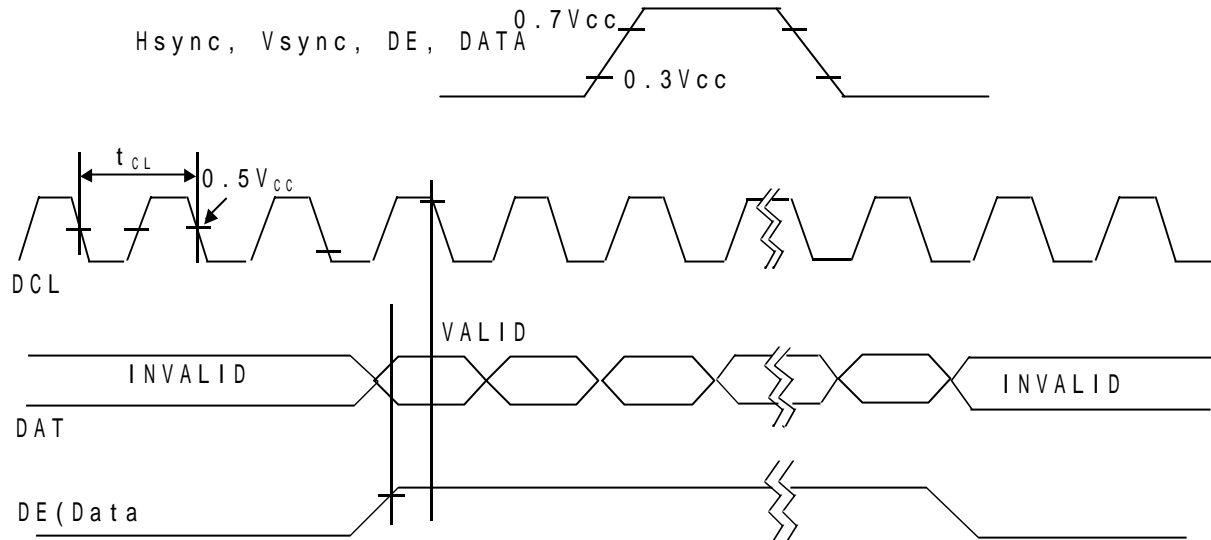

Product Specification

3-5. Color Input Data Reference

The brightness of each primary color(red, green and blue) is based on the 6bit gray scale data input for the color; the higher the binary input, the brighter the color. The table below provides a reference for color versus data input.

Table 7 COLOR DATA REFERENCE

Color		Input Color Data																	
		Red						Green						Blue					
		MSB			LSB			MSB			LSB			MSB		LSB			
		R5	R4	R3	R2	R1	R0	G5	G4	G3	G2	G1	G0	B5	B4	B3	B2	B1	B0
Basic Colors	Black	0	0	0	0	0	0	0	0	0	0	0	0	0	0	0	0	0	0
	Red(63)	1	1	1	1	1	1	0	0	0	0	0	0	0	0	0	0	0	0
	Green(63)	0	0	0	0	0	0	1	1	1	1	1	1	0	0	0	0	0	0
	Blue(63)	0	0	0	0	0	0	0	0	0	0	0	0	1	1	1	1	1	1
	Cyan	0	0	0	0	0	0	1	1	1	1	1	1	1	1	1	1	1	1
	Magenta	1	1	1	1	1	1	0	0	0	0	0	0	1	1	1	1	1	1
	Yellow	1	1	1	1	1	1	1	1	1	1	1	1	0	0	0	0	0	0
	White	1	1	1	1	1	1	1	1	1	1	1	1	1	1	1	1	1	1
Red	Red(00) Dark	0	0	0	0	0	0	0	0	0	0	0	0	0	0	0	0	0	0
	Red(01)	0	0	0	0	0	1	0	0	0	0	0	0	0	0	0	0	0	0
	Red(02)	0	0	0	0	1	0	0	0	0	0	0	0	0	0	0	0	0	0
	:	:	:	:	:	:	:	:	:	:	:	:	:	:	:	:	:	:	:
	Red(61)	1	1	1	1	0	1	0	0	0	0	0	0	0	0	0	0	0	0
	Red(62)	1	1	1	1	1	0	0	0	0	0	0	0	0	0	0	0	0	0
	Red(63) Bright	1	1	1	1	1	1	0	0	0	0	0	0	0	0	0	0	0	0
Green	Green(00)Dark	0	0	0	0	0	0	0	0	0	0	0	0	0	0	0	0	0	0
	Green(01)	0	0	0	0	0	0	0	0	0	0	1	0	0	0	0	0	0	
	Green(02)	0	0	0	0	0	0	0	0	0	0	1	0	0	0	0	0	0	
	:	:	:	:	:	:	:	:	:	:	:	:	:	:	:	:	:	:	
	Green(61)	0	0	0	0	0	0	1	1	1	1	0	1	0	0	0	0	0	
	Green(62)	0	0	0	0	0	0	1	1	1	1	1	0	0	0	0	0	0	
	Green(63)Bright	0	0	0	0	0	0	1	1	1	1	1	1	0	0	0	0	0	
Blue	Blue(00) Dark	0	0	0	0	0	0	0	0	0	0	0	0	0	0	0	0	0	0
	Blue(01)	0	0	0	0	0	0	0	0	0	0	0	0	0	0	0	0	0	1
	Blue(02)	0	0	0	0	0	0	0	0	0	0	0	0	0	0	0	0	1	0
	:	:	:	:	:	:	:	:	:	:	:	:	:	:	:	:	:	:	:
	Blue(61)	0	0	0	0	0	0	0	0	0	0	0	0	1	1	1	1	0	1
	Blue(62)	0	0	0	0	0	0	0	0	0	0	0	0	1	1	1	1	1	0
	Blue(63) Bright	0	0	0	0	0	0	0	0	0	0	0	0	1	1	1	1	1	1

Product Specification

4. Optical Specifications

Optical characteristics are determined after the unit has been 'ON' and stable for approximately 30 minutes in a dark environment at 25 °C. The values specified are at an approximate distance 50cm from the LCD surface at a viewing angle of Φ and θ equal to 0°.

Appendix A -1 presents additional information concerning the measurement equipment and method..

Table 8 OPTICAL CHARACTERISTICS (Ta=25 °C, Vcc=3.3V, f_v =60Hz, Dclk=65MHz, I_L=6.0mA)

Parameter	Symbol	Values			Units	Notes
		Min.	Typ.	Max.		
Contrast Ratio	CR	100	300	-		1
Surface Luminance, white	L _{WH}	130	150	-	cd/m ²	2
Luminance Variation	WHITE	-	-	1.45		3
Response Time	Tr				ms	4
Rise Time	Tr _R	-	-	30		
Decay Time	Tr _D	-	-	50		
CIE Chromaticity						2
Red	X _R	0.547	0.577	0.607		
	Y _R	0.308	0.338	0.368		
Green	X _G	0.280	0.310	0.340		
	Y _G	0.533	0.563	0.593		
Blue	X _B	0.128	0.158	0.188		
	Y _B	0.127	0.157	0.187		
White	X _W	0.283	0.313	0.343		-
	Y _W	0.299	0.329	0.359		-
Viewing Angle					degree	5
x axis, right (Φ =0°)	r	40	-	-		
x axis, left(Φ =180°)	l	40	-	-		
y axis, up(θ =90°)	u	10	-	-		
y axis, down (θ =270°)	d	30	-	-		
Gray Scale		-	-	-		6

Notes 1. Contrast Ratio (CR) is defined mathematically as :

$$\text{Contrast Ratio} = \frac{\text{Surface Luminance with all white pixels}}{\text{Surface Luminance with all black pixels}}$$

2. Surface luminance is measured at the center 1 point of 50cm from the surface with all pixels displaying white. For more information see Appendix A - 2.

The condition of luminance spec is when I_L is typical 6.0mA.

3. The variation in surface Luminance, WHITE is determined by measuring L_{ON} at each test position 1 through 5, and then dividing the maximum L_{ON} of 5 points luminance by minimum L_{ON} of 5 points luminance. For more information see Appendix A - 2.

$$\text{WHITE} = \text{Maximum} (L_{ON1}, L_{ON2}, \dots, L_{ON5}) \div \text{Minimum} (L_{ON1}, L_{ON2}, \dots, L_{ON5})$$

4. Response time is the time required for the display to transition from white to black (Rise Time, Tr_R) and from black to white (Decay Time, Tr_D). For additional information see Appendix A - 3.

Product Specification

5. Viewing angle is the angle at which the contrast ratio is greater than 10. The angles are determined for the horizontal or x axis and the vertical or y axis with respect to the z axis which is normal to the LCD surface. For more information see Appendix A - 4
6. Gray scale specification.

Gray Level	Luminance (%)(typ)
L0	0.5
L7	1.8
L15	4.3
L23	9.6
L31	21.6
L39	38.5
L47	59.6
L55	85.5
L63	100

5. Mechanical Characteristics

The contents provide general mechanical characteristics for the model LP150X1-F2IB LCD. In addition, the figures in the next page are detailed mechanical drawings of the LCD.

Outside dimensions :

Horizontal	315.5 ± 0.5 mm
Vertical	242.3 ± 0.5 mm
Depth	7.0 ± 0.3 mm

Bezel area :

Horizontal	308.5 ± 0.5 mm
Vertical	232.5 ± 0.5 mm

Active Display area :

Horizontal	304.128 mm
Vertical	228.096 mm

Weight (approximate) : 685g (typ), 700g (max)

Surface Treatment : Hard coating 3H.

Anti-glare treatment of the front polarizer

Product Specification

< FRONT VIEW >

Product Specification

< DETAIL DESCRIPTION OF SIDE MOUNTING SCREW >

Structure of joint

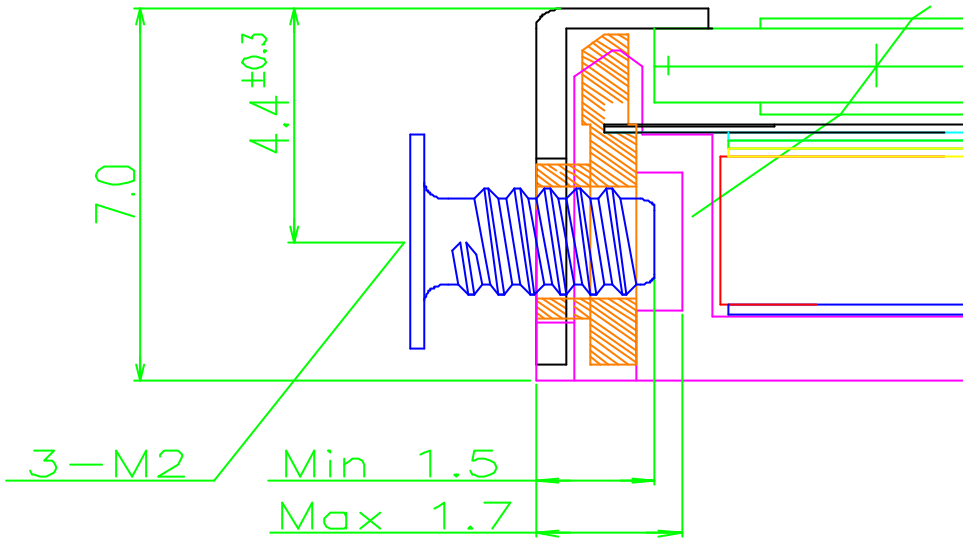

< LEFT >

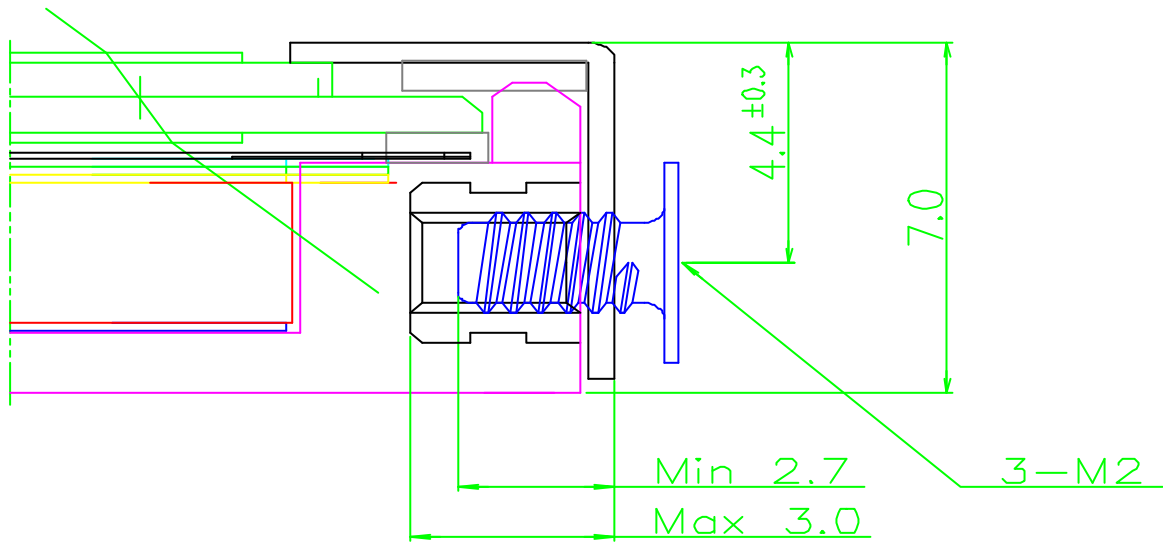

< RIGHT >

* Mounting Screw Depth : 1.5[mm] Min. 1.7[mm] Max. -LEFT

2.7[mm] Min. 3.0[mm] Max. -RIGHT

* Torque : 1.3 ~ 1.5 [kgf · cm]

Product Specification

6. Reliability

- Environment test condition

No.	Test Item	Conditions
1	High temperature storage test	Ta = 60 240h
2	Low temperature storage test	Ta = -20 240h
3	High temperature operation test	Ta = 50 50%RH 240h
4	Low temperature operation test	Ta = 0 240h
5	Vibration test (non-operating)	Sine wave, 10~500~10Hz, 1.5G, 0.37oct/min, 3 axis, 1 hour/axis
6	Shock test (non-operating)	Half sine wave, 180G, 2ms, one shock of each six faces (i.e. run 180G 2ms for all six faces.)
7	Altitude operating storage/shipment	0 - 10,000 feet (3048m) 0 - 40,000 feet (12192m)

{Result Evaluation Criteria}

There should be no change which might affect the practical display function when the display quality test is conducted under normal operating condition.

- ON/OFF Cycle

: The display module will be capable of being operated over 24,000 ON/OFF cycles (Lamp power & Vcc ON/OFF)

- Mean Time Between Failure

: The LCD Panel and interface board assembly (excluding the CCFL) have a mean time between failures of 30,000 hours with a confidence level 90%.

7. International Standards

7-1. Safety

- a) UL 1950 Third Edition, Underwriters Laboratories, Inc. Jan. 28, 1995.
Standard for Safety of Information Technology Equipment Including Electrical Business Equipment.
- b) CAN/CSA C22.2 No. 950-95 Third Edition, Canadian Standards Association, Jan. 28, 1995.
Standard for Safety of Information Technology Equipment Including Electrical Business Equipment.
- c) EN 60950 : 1992 + A1 : 1993 + A2 : 1993 + A3 : 1995 + A4 : 1997 + A11 : 1997
IEC 950 : 1991 + A1 : 1992 + A2 : 1993 + A3 : 1995 + A4 : 1996
European Committee for Electrotechnical Standardization (CENELEC)
EUROPEAN STANDARD for Safety of Information Technology Equipment Including Electrical Business Equipment.

7-2. EMC

- a) ANSI C63.4 "Methods of Measurement of Radio-Noise Emissions from Low-Voltage Electrical and Electronic Equipment in the Range of 9kHz to 40GHz." American National Standards Institute(ANSI),1992.
- b) C.I.S.P.R "Limits and Methods of Measurement of Radio Interference Characteristics of Information Technology Equipment." International Special Committee on Radio Interference
- c) EN 55022 "Limits and Methods of Measurement of Radio Interference Characteristics of Information Technology Equipment." European Committee for Electrotechnical Standardization (CENELEC),1988

Product Specification

8. Packing

8-1. Designation of Lot Mark

a) Lot Mark

A	B	C	D	E	F	G	H	I	J	K	L	M
---	---	---	---	---	---	---	---	---	---	---	---	---

A, B, C : INCH CODE
 D : YEAR
 E : MONTH
 F,G : Panel Code
 H : Assembly Code
 I, J, K, L, M : Serial NO.

Note : 1. YEAR

YEAR	97	98	99	2000	2001	2002	2003	2004	2005	2006	2007
Mark	7	8	9	0	1	2	3	4	5	6	7

2. MONTH

MONTH	Jan.	Feb.	Mar.	Apr.	May	Jun.	Jul.	Aug.	Sep.	Oct.	Nov.	Dec.
Mark	1	2	3	4	5	6	7	8	9	A	B	C

b) Location of Lot Mark

Serial NO. Is printed on the label. The label is attached to the backside of the LCD module.
 This is subject to change without prior notice.

8-2. Packing Form

a) Package quantity in one box : 10 pcs

b) Box Size : 360 X 322 X 391mm

9.PRECAUTIONS

Please pay attention to the followings when you use this TFT LCD module.

9.1 MOUNTING PRECAUTIONS

- (1) You must mount a module using holes arranged in four corners or four sides.
- (2) You should consider the mounting structure so that uneven force (ex. twisted stress) is not applied to the module.
And the case on which a module is mounted should have sufficient strength so that external force is not transmitted directly to the module.
- (3) Please attach a transparent protective plate to the surface in order to protect the polarizer.
Transparent protective plate should have sufficient strength in order to resist external force.
- (4) You should adopt radiation structure to satisfy the temperature specification.
- (5) Acetic acid type and chlorine type materials for the cover case are not desirable because the former generates corrosive gas of attacking the polarizer at high temperature and the latter causes circuit break by electro-chemical reaction.
- (6) Do not touch, push or rub the exposed polarizers with glass, tweezers or anything harder than HB pencil lead. And Please do not rub with dust clothes with chemical treatment.
Do not touch the surface of polarizer for bare hand or greasy cloth. (Some cosmetics are detrimental to the polarizer.)
- (7) When the surface becomes dusty, please wipe gently with absorbent cotton or other soft materials like chamois soaked with petroleum benzene. Normal-hexane is recommended for cleaning the adhesives used to attach front / rear polarizers. Do not use acetone, toluen and alcohol because they cause chemical damage to the polarizer.
- (8) Wipe off saliva or water drops as soon as possible. Their long time contact with polarizer causes deformations and color fading.
- (9) Do not open the case because inside circuits do not have sufficient strength.

9.2 OPERATING PRECAUTIONS

- (1) The spike noise causes the mis-operation of circuits. It should be lower than following voltage :
 $V = \pm 200\text{mV}$ (Over and under shoot voltage).
- (2) Response time depends on the temperature. (In lower temperature, it becomes longer.)
- (3) Brightness depends on the temperature. (In lower temperature, it becomes lower.)
And in lower temperature, response time (required time that brightness is stable after turned on) becomes longer.
- (4) Be careful for condensation at sudden temperature change. Condensation makes damage to polarizer or electrical contacted parts. And after fading condensation, smear or spot will occur.
- (5) When fixed patterns are displayed for a long time, remnant image is likely to occur.
- (6) Module has high frequency circuits. Sufficient suppression to the electromagnetic interference shall be done by system manufacturers. Grounding and shielding methods may be important to

Product Specification

minimize the interference.

9.3 ELECTROSTATIC DISCHARGE CONTROL

Since a module is composed of electronic circuits, it is not strong to electrostatic discharge. Make certain that treatment persons are connected to ground through wrist band etc . And don' t touch interface pin directly.

9.4 PRECAUTIONS FOR STRONG LIGHT EXPOSURE

Strong light exposure causes degradation of polarizer and color filter.

9.5 STORAGE

When storing modules as spares for a long time, the following precautions are necessary.

- (1) Store them in a dark place. Do not expose the module to sunlight or fluorescent light. Keep the temperature between 5 and 35 at normal humidity.
- (2) The polarizer surface should not come in contact with any other object.
It is recommended that they be stored in the container in which they were shipped.

9.6 HANDLING PRECAUTIONS FOR PROTECTION FILM

- (1) When the protection film is peeled off, static electricity is generated between the film and polarizer.
This should be peeled off slowly and carefully by people who are electrically grounded and with well ion- blown equipment or in such a condition, etc..
- (2) The protection film is attached to the polarizer with a small amount of glue. If some stress is applied to rub the protection film against the polarizer during the time you peel off the film, the glue is apt to remain on the polarizer.
Please carefully peel off the protection film without rubbing it against the polarizer.
- (3) When the module with protection film attached is stored for a long time, sometimes there remains a very small amount of glue still on the polarizer after the protection film is peeled off.
- (4) You can remove the glue easily. When the glue remains on the polarizer surface or its vestige is recognized, please wipe them off with absorbent cotton waste or other soft material like chamois soaked with normal-hexane.

