

TENTATIVE

All information in this technical data sheet is tentative
and subject to change without notice.

15.0"XGA

TECHNICAL SPECIFICATION

AA150XN01

mitsubishi / MDTI

Date: Nov.6, '03

CONTENTS

No.	Item	Page
--	COVER	1
--	CONTENTS	2
1	OVERVIEW	3
2	ABSOLUTE MAXIMUM RATINGS	4
3	ELECTRICAL CHARACTERISTICS	4, 5, 6
4	INTERFACE PIN CONNECTION	7, 8
5	INTERFACE TIMING	9, 10, 11, 12, 13
6	BLOCK DIAGRAM	14
7	MECHANICAL SPECIFICATION	15, 16
8	OPTICAL CHARACTERISTICS	17, 18
9	RELIABILITY TEST CONDITION	19
10	HANDLING PRECAUTIONS FOR TFT-LCD MODULE	20, 21, 22

1. OVERVIEW

AA150XN01 is 15.0" color TFT-LCD (Thin Film Transistor Liquid Crystal Display) modules composed of LCD panel, driver ICs, control circuit, and backlight unit.

By applying 6 bit or 8 bit digital data, 1024 × 768, 260K-color or 16.1M-color images are displayed on the 15.0" diagonal screen. Input power voltages are 3.3 V for LCD driving.

General specifications are summarized in the following table:

ITEM	SPECIFICATION
Display Area (mm)	304.1 (H) × 228.1 (V) (15.0-inch diagonal)
Number of Dots	1024 × 3 (H) × 768 (V)
Pixel Pitch (mm)	0.297 (H) × 0.297 (V)
Color Pixel Arrangement	RGB vertical stripe
Display Mode	Normally white TN
Number of Color	260K(6 bit/color) 16.1 M(8 bit/color)
Brightness	250 cd/m ² (Typ.)
Wide Viewing Angle Technology	Optical Compensation Film
Viewing Angle	-75~75° (H) -60~50° (V)
Surface Treatment	Anti-glare and hard-coating 3H
Electrical Interface	LVDS(6 bit/8 bit)
Optimum Viewing Angle(Contrast ratio)	6 o'clock
Module Size (mm)	326.0 (W) × 255.0 (H) × 15.9 (D)
Module Mass (g)	1290
Backlight Unit	CCFL, 2-tubes, edge-light, replaceable

Sign "()" represents preliminary value. Characteristic value without any note is typical value.

The LCD product described in this specification is designed and manufactured for the standard use in OA equipment and consumer products, such as computers, communication equipment, industrial robots, AV equipment and so on.

Do not use the LCD product for the equipment that require the extreme high level of reliability, such as aerospace applications, submarine cables, nuclear power control systems and medical or other equipment for life support.

MDTI assumes no responsibility for any damage resulting from the use of the LCD product in disregard of the conditions and handling precautions in this specification.

If customers intend to use the LCD product for the above items or other no standard items, please contact our sales persons in advance.

2. ABSOLUTE MAXIMUM RATINGS

ITEM	SYMBOL	MIN.	MAX.	UNIT
Power Supply Voltage for LCD	VCC	0	4.0	V
Logic Input Voltage	VI	-0.3	VCC+0.3	V
Lamp Voltage	VL	0	2500	Vrms
Lamp Current	IL	0	10.0	mArms
Lamp Frequency	FL	--	100	kHz
Operation Temperature *)	T _{op}	0	50	°C
Storage Temperature *)	T _{stg}	-20	60	°C

[Note]

*) Top, Tstg ≤ 40°C : 90% RH max. without condensation

Top, Tstg > 40°C : Absolute humidity shall be less than the value of 90% RH at 40°C without condensation.

3. ELECTRICAL CHARACTERISTICS

(1) TFT- LCD

Ambient Temperature : Ta = 25°C

ITEM	SYMBOL	MIN.	TYP.	MAX.	UNIT	Remarks
Power Supply Voltages for LCD	VCC	3.0	3.3	3.6	V	*1)
Power Supply Currents for LCD	ICC	--	(400)	TBD	mA	*2)
Permissible Input Ripple Voltage	VRP	--	--	100	mVp-p	VCC = +3.3 V

*1) Power and signals sequence:

$$\begin{aligned}
 0.5 \leq t_1 \leq 10 \text{ ms} & & 500 \text{ ms} \leq t_4 \\
 0 \leq t_2 \leq 50 \text{ ms} & & 200 \text{ ms} \leq t_5 \\
 0 < t_3 \leq 50 \text{ ms} & & 0 \leq t_6
 \end{aligned}$$

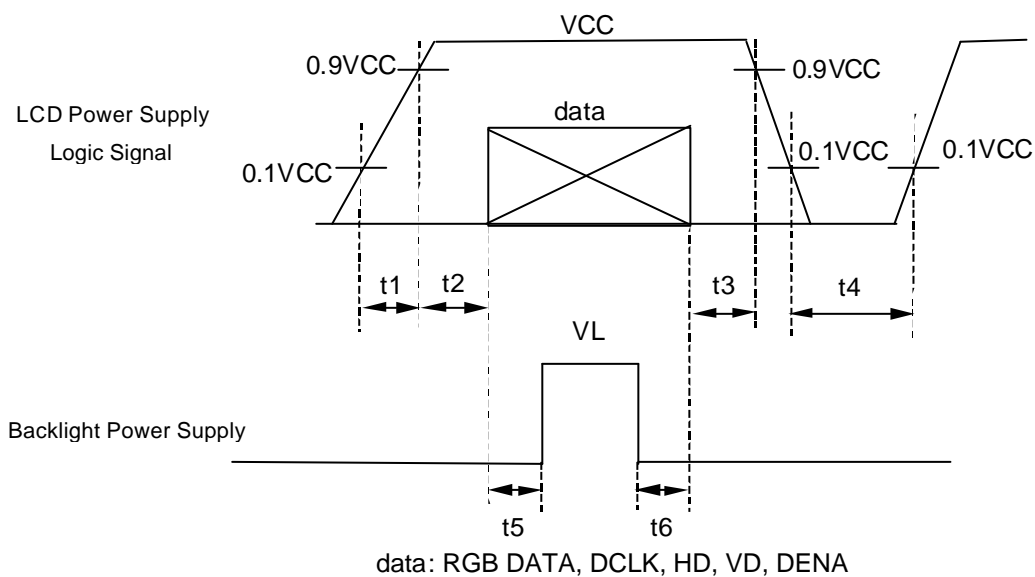

VCC-dip conditions:

- 1) When $2.6\text{ V} \leq VCC < 3.0\text{ V}$, $t_d \leq 10\text{ ms}$
- 2) When $VCC < 2.6\text{ V}$

VCC-dip conditions should also follow the power and signals sequence.

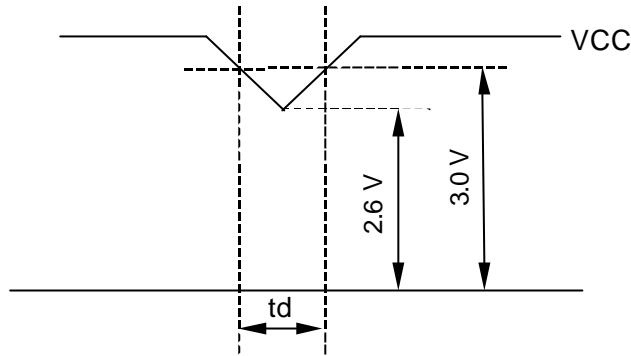

*2) Typical current condition:

- 64-gray-bar pattern(6 bit)
- 253- gray- bar-pattern(8 bit)
- 768 line mode
- $VCC = +3.3\text{ V}$, $f_H = 48.4\text{ kHz}$, $f_V = 60\text{ Hz}$, $f_{CLK} = 65\text{ MHz}$

(2) Backlight

$T_a = 25^\circ\text{C}$

ITEM	SYMBOL	MIN.	TYP.	MAX.	UNIT	Remarks
Lamp Voltage	VL	--	570	--	Vrms	$IL = 6.5\text{ mArms}$
Lamp Current	IL	3.5	6.5	8.0	mArms	*1)*4)
Lamp Frequency	FL	40	--	70	kHz	*2)
Starting Lamp Voltage	VS	1400	--	--	Vrms	$T_a = 0^\circ\text{C}$
		1200	--	--	Vrms	$T_a = 25^\circ\text{C}$
Lamp Life Time	LT	--	50000	--	h	*3), $IL = 6.5\text{ mArms}$, Continuous Operation

*1) Lamp Current measurement method (The current meter is inserted in low voltage line.)

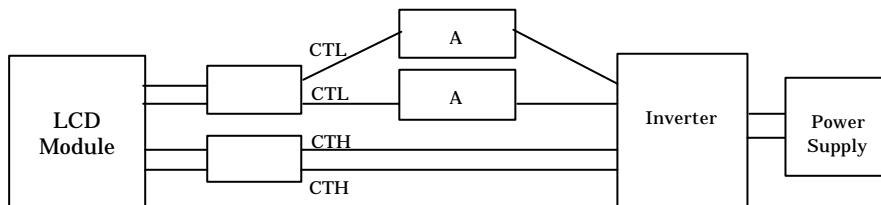

*2) Lamp frequency of inverter may produce interference with horizontal synchronous frequency, and this may cause horizontal beat on the display. Therefore, please adjust lamp frequency, and keep inverter as far from module as possible or use electronic shielding between inverter and module to avoid the interference.

*3) Lamp life time is defined as the time either when the brightness becomes 50% of the initial value, or when the starting lamp voltage does not meet the value specified in this table.

*4) Please use the inverter which has symmetrical current wave form as follows,

The degree of unbalance: less than 10%

The ratio of wave height: less than $\sqrt{2} \pm 10\%$

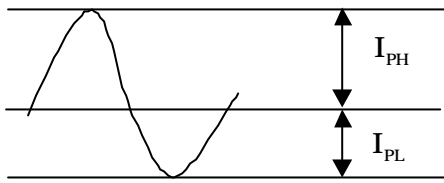

I_{PH} : High side peak

I_{PL} : Low side peak

The degree of unbalance = $|I_{PH} - I_{PL}| / I_{rms} \times 100(\%)$
The ratio of wave height = $I_{PH} \text{ (or } I_{PL}) / I_{rms}$

CURRENT WAVE FORM

4. INTERFACE PIN CONNECTION

(1) CN 1(Interface Signal)

Used Connector: DF14H-20P-1.25H(HIROSE)

Corresponding connector: DF14-20S-1.25C(HIROSE)

Pin No.	Symbol	Function(ISP 6 bit compatibility mode)		Function(ISP 8 bit compatibility mode)
		6 bit input	8 bit input	
1	VCC	+3.3 V Power supply		←
2	VCC	+3.3 V Power supply		←
3	GND	GND		←
4	GND	GND		←
5	Link 0-	R0, R1, R2, R3, R4, R5, G0	R2, R3, R4, R5, R6, R7, G2	R0, R1, R2, R3, R4, R5, G0
6	Link 0+	R0, R1, R2, R3, R4, R5, G0	R2, R3, R4, R5, R6, R7, G2	R0, R1, R2, R3, R4, R5, G0
7	GND	GND		←
8	Link 1-	G1, G2, G3, G4, G5, B0, B1	G3, G4, G5, G6, G7, B2, B3	G1, G2, G3, G4, G5, B0, B1
9	Link 1+	G1, G2, G3, G4, G5, B0, B1	G3, G4, G5, G6, G7, B2, B3	G1, G2, G3, G4, G5, B0, B1
10	GND	GND		←
11	Link 2-	B2, B3, B4, B5, HD, VD, DENA	B4, B5, B6, B7, HD, VD, DENA	B2, B3, B4, B5, HD, VD, DENA
12	Link 2+	B2, B3, B4, B5, HD, VD, DENA	B4, B5, B6, B7, HD, VD, DENA	B2, B3, B4, B5, HD, VD, DENA
13	GND	GND		←
14	CLKIN-	Clock -		←
15	CLKIN+	Clock +		←
16	GND	GND		←
17	Link3-	GND	R0, R1, G0, G1, B0, B1	R6, R7, G6, G7, B6, B7
18	Link3+	GND	R0, R1, G0, G1, B0, B1	R6, R7, G6, G7, B6, B7
19	MODE	L=ISP 6 bit compatibility mode		H=ISP 8 bit compatibility mode
20	SC	Reverse scan control. (L : Normal , H : Reverse)		←

(2) CN 2(Backlight)

Backlight-side connector: BHSR-02VS-1(JST)

Inverter-side connector: SM02B-BHSS-1-TB

Pin No.	Symbol	Function
1, 2	CTH	VBLH (High Voltage)

[Note] VBLH-VBLL = VL

(3) CN 3(Backlight)

Backlight-side connector: BHR-02VS-1(JST)

Inverter-side connector: SM02(4.0)B-BHS-1-TB

Pin No.	Symbol	Function
1, 2	CTL	VBLL (Low Voltage)

[Note] VBLH-VBLL = VL

(4) ISP data mapping

a. ISP 6 bit compatibility mode(6 bit input)

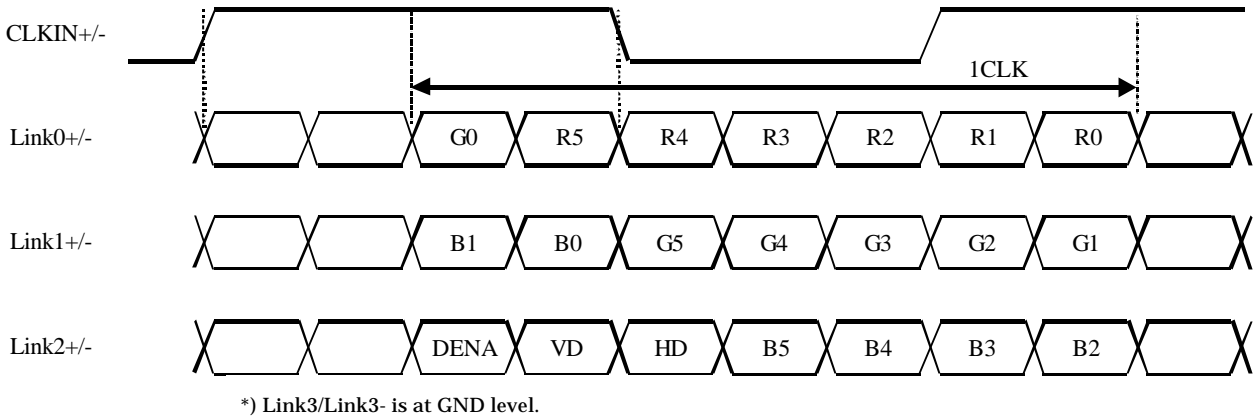

b. ISP 6 bit compatibility mode(8 bit input)

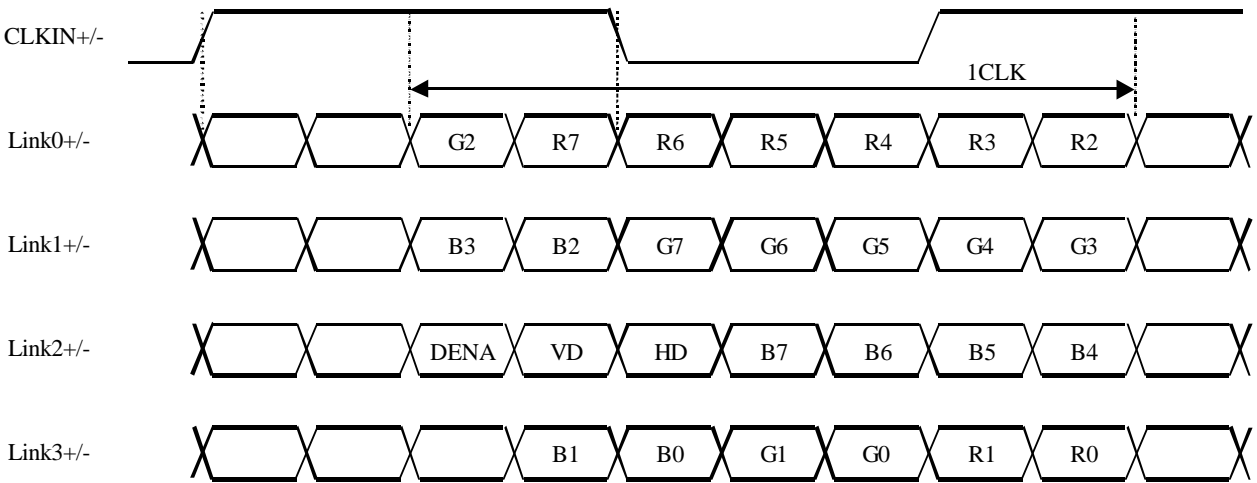

c. ISP 8 bit compatibility mode

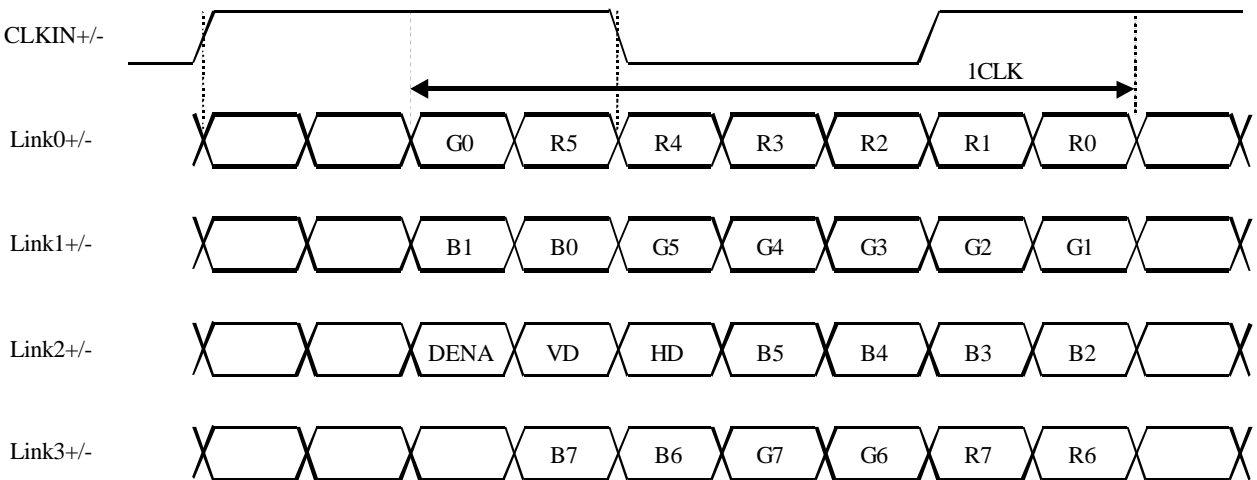

5. INTERFACE TIMING

LVDS transmitter input signal

(1) Timing Specifications

ITEM		SYMBOL	MIN.	TYP.	MAX.	UNIT	
LCD Timing	DCLK	Frequency	f_{CLK}	50	65	80	MHz
		Period	t_{CLK}	12.5	15.4	20	ns
	DENA	Horizontal Active Time	t_{HA}	1024	1024	1024	t_{CLK}
		Horizontal Front Porch	t_{HFP}	0	24	--	t_{CLK}
		Horizontal Back Porch	t_{HBP}	4	296	--	t_{CLK}
		Vertical Active Time	t_{VA}	768	768	768	t_H
		Vertical Front Porch	t_{VFP}	2	3	--	t_H
		Vertical Back Porch	t_{VBP}	1	35	--	t_H
	HD	Frequency	f_H	42.4	48.4	60	kHz
		Period	t_H	16.6	20.7	23.6	μ s
		Low Width	t_{WHL}	1	136	--	t_{CLK}
	VD	Frequency	f_V	55	60	75	Hz
		Period	t_V	13.3	16.7	18.2	ms
		Low Width	t_{WVL}	5	6	--	t_H

[Note]

- *1) Polarities of HD and VD are negative in this specification.
- *2) DENA (Data Enable) should always be positive polarity as shown in the timing specification.
- *3) DCLK should appear during all invalid period, and HD should appear during invalid period of frame cycle.
- *4) LVDS timing follows the timing specifications of LVDS receiver IC: THC63LVDF84A(Thine).
- *5) $t_{HFP} + t_{HBP} \geq 15DCLK$

(2) Timing Chart

a. Horizontal Timing Chart

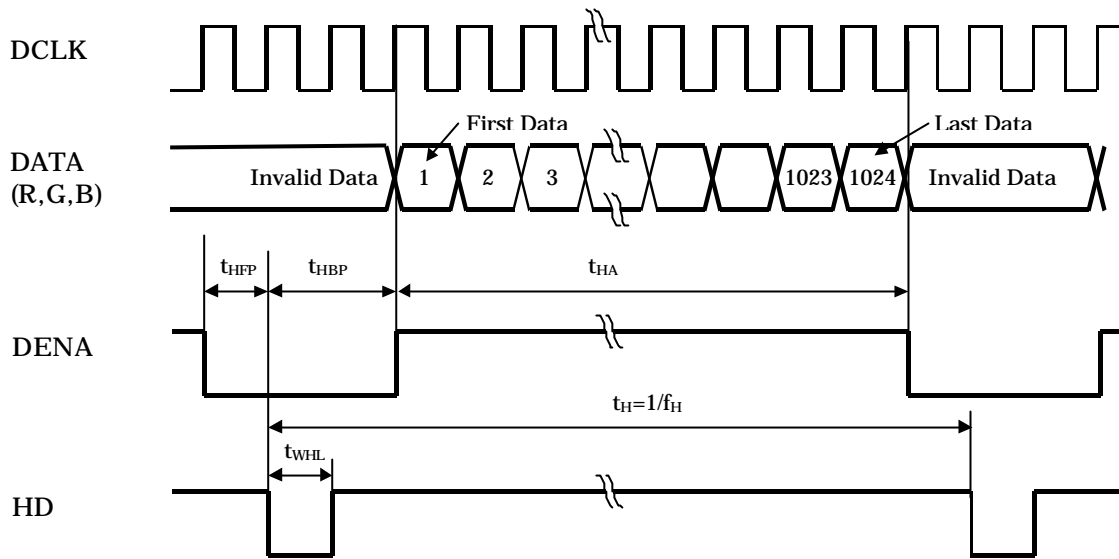

b. Vertical Timing Chart

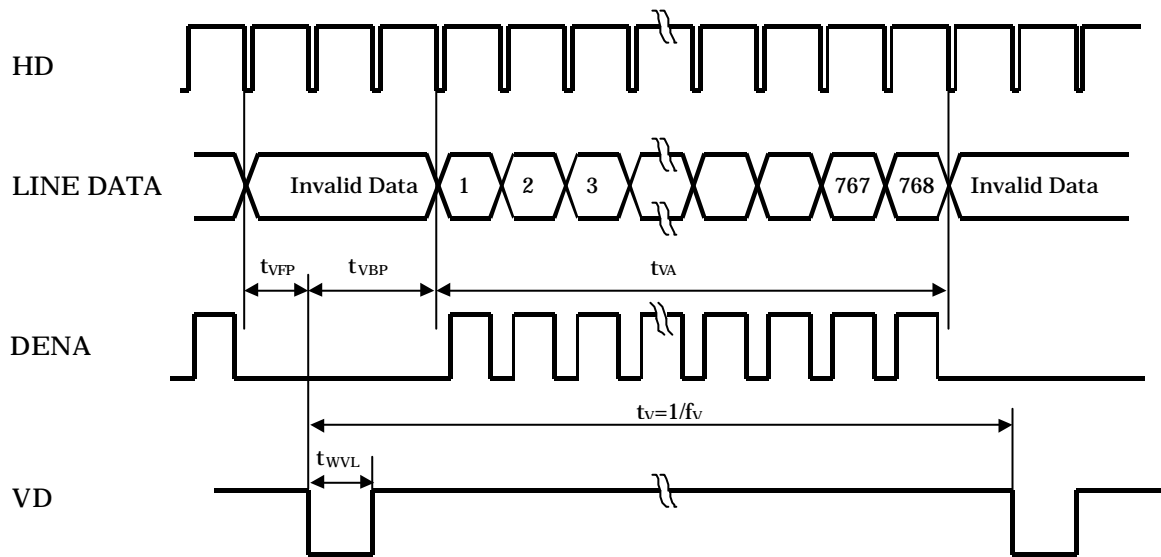

(3) Color Data Assignment

a. 6 bit input

COLOR	INPUT DATA	R DATA						G DATA						B DATA					
		R5	R4	R3	R2	R1	R0	G5	G4	G3	G2	G1	G0	B5	B4	B3	B2	B1	B0
		MSB					LSB	MSB					LSB	MSB					LSB
BASIC COLOR	BLACK	0	0	0	0	0	0	0	0	0	0	0	0	0	0	0	0	0	0
	RED(63)	1	1	1	1	1	1	0	0	0	0	0	0	0	0	0	0	0	0
	GREEN(63)	0	0	0	0	0	0	1	1	1	1	1	1	0	0	0	0	0	0
	BLUE(63)	0	0	0	0	0	0	0	0	0	0	0	0	1	1	1	1	1	1
	CYAN	0	0	0	0	0	0	1	1	1	1	1	1	1	1	1	1	1	1
	MAGENTA	1	1	1	1	1	1	0	0	0	0	0	0	1	1	1	1	1	1
	YELLOW	1	1	1	1	1	1	1	1	1	1	1	1	0	0	0	0	0	0
	WHITE	1	1	1	1	1	1	1	1	1	1	1	1	1	1	1	1	1	1
RED	RED(0)	0	0	0	0	0	0	0	0	0	0	0	0	0	0	0	0	0	0
	RED(1)	0	0	0	0	0	1	0	0	0	0	0	0	0	0	0	0	0	0
	RED(2)	0	0	0	0	1	0	0	0	0	0	0	0	0	0	0	0	0	0
	RED(62)	1	1	1	1	1	0	0	0	0	0	0	0	0	0	0	0	0	0
	RED(63)	1	1	1	1	1	1	0	0	0	0	0	0	0	0	0	0	0	0
GREEN	GREEN(0)	0	0	0	0	0	0	0	0	0	0	0	0	0	0	0	0	0	0
	GREEN(1)	0	0	0	0	0	0	0	0	0	0	0	1	0	0	0	0	0	0
	GREEN(2)	0	0	0	0	0	0	0	0	0	0	1	0	0	0	0	0	0	0
	GREEN(62)	0	0	0	0	0	0	1	1	1	1	1	0	0	0	0	0	0	0
	GREEN(63)	0	0	0	0	0	0	1	1	1	1	1	1	0	0	0	0	0	0
BLUE	BLUE(0)	0	0	0	0	0	0	0	0	0	0	0	0	0	0	0	0	0	0
	BLUE(1)	0	0	0	0	0	0	0	0	0	0	0	0	0	0	0	0	0	1
	BLUE(2)	0	0	0	0	0	0	0	0	0	0	0	0	0	0	0	0	1	0
	BLUE(62)	0	0	0	0	0	0	0	0	0	0	0	0	1	1	1	1	1	0
	BLUE(63)	0	0	0	0	0	0	0	0	0	0	0	0	1	1	1	1	1	1

[Note]

1) Definition of gray scale

Color (n) --- n indicates gray scale level.

Higher n means brighter level.

2) Data

1:High, 0: Low

b. 8 bit input

COLOR	INPUT DATA	R DATA								G DATA								B DATA							
		R7	R6	R5	R4	R3	R2	R1	R0	G7	G6	G5	G4	G3	G2	G1	G0	B7	B6	B5	B4	B3	B2	B1	B0
		MSB							LSB	MSB							LSB	MSB							LSB
BASIC COLOR	BLACK	0	0	0	0	0	0	0	0	0	0	0	0	0	0	0	0	0	0	0	0	0	0	0	0
	RED(252)	1	1	1	1	1	1	*	*	0	0	0	0	0	0	0	0	0	0	0	0	0	0	0	0
	GREEN(252)	0	0	0	0	0	0	0	0	1	1	1	1	1	1	*	*	0	0	0	0	0	0	0	0
	BLUE(252)	0	0	0	0	0	0	0	0	0	0	0	0	0	0	0	0	1	1	1	1	1	1	*	*
	CYAN	0	0	0	0	0	0	0	0	1	1	1	1	1	1	1	1	1	1	1	1	1	1	1	1
	MAGENTA	1	1	1	1	1	1	1	1	0	0	0	0	0	0	0	0	1	1	1	1	1	1	1	1
	YELLOW	1	1	1	1	1	1	1	1	1	1	1	1	1	1	1	1	0	0	0	0	0	0	0	0
	WHITE	1	1	1	1	1	1	1	1	1	1	1	1	1	1	1	1	1	1	1	1	1	1	1	1
RED	RED(0)	0	0	0	0	0	0	0	0	0	0	0	0	0	0	0	0	0	0	0	0	0	0	0	0
	RED(1)	0	0	0	0	0	0	0	1	0	0	0	0	0	0	0	0	0	0	0	0	0	0	0	0
	RED(2)	0	0	0	0	0	0	1	0	0	0	0	0	0	0	0	0	0	0	0	0	0	0	0	0
	RED(252)	1	1	1	1	1	1	*	*	0	0	0	0	0	0	0	0	0	0	0	0	0	0	0	0
GREEN	GREEN(0)	0	0	0	0	0	0	0	0	0	0	0	0	0	0	0	0	0	0	0	0	0	0	0	0
	GREEN(1)	0	0	0	0	0	0	0	0	0	0	0	0	0	0	1	0	0	0	0	0	0	0	0	0
	GREEN(2)	0	0	0	0	0	0	0	0	0	0	0	0	0	1	0	0	0	0	0	0	0	0	0	0
GREEN(252)	0	0	0	0	0	0	0	0	1	1	1	1	1	1	*	*	0	0	0	0	0	0	0	0	
BLUE	BLUE(0)	0	0	0	0	0	0	0	0	0	0	0	0	0	0	0	0	0	0	0	0	0	0	0	0
	BLUE(1)	0	0	0	0	0	0	0	0	0	0	0	0	0	0	0	0	0	0	0	0	0	0	0	1
	BLUE(2)	0	0	0	0	0	0	0	0	0	0	0	0	0	0	0	0	0	0	0	0	0	0	1	0
BLUE(252)	0	0	0	0	0	0	0	0	0	0	0	0	0	0	0	0	1	1	1	1	1	1	*	*	

[Note]

*1) Definition of gray scale

Color (n) --- n indicates gray scale level.
Higher n means brighter level.

*2) Data

1:High, 0: Low, *: High or Low

(4) Data Mapping

D(1, 1)	D(2, 1)	---	D(X, 1)	---	D(1023, 1)	D(1024, 1)
D(1, 2)	D(2, 2)	---	D(X, 2)	---	D(1023, 2)	D(1024, 2)
⋮	⋮	+	⋮	+	⋮	⋮
D(1, Y)	D(2, Y)	---	D(X, Y)	---	D(1023, Y)	D(1024, Y)
⋮	⋮	+	⋮	+	⋮	⋮
D(1,767)	D(2,767)	---	D(X,767)	---	D(1023,767)	D(1024,767)
D(1,768)	D(2,768)	---	D(X,768)	---	D(1023,768)	D(1024,768)

6. BLOCK DIAGRAM

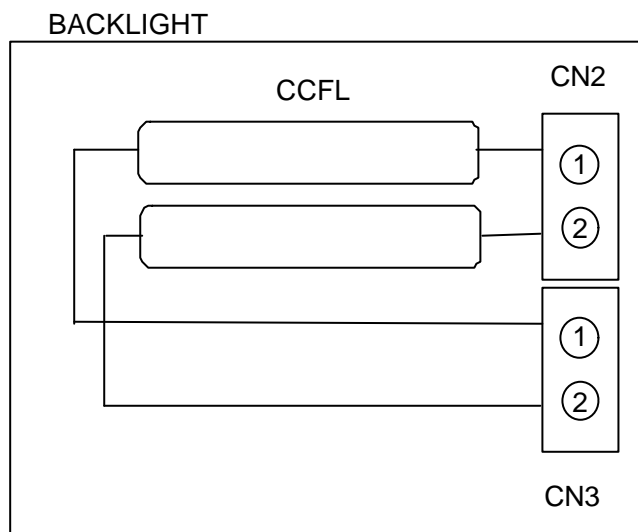
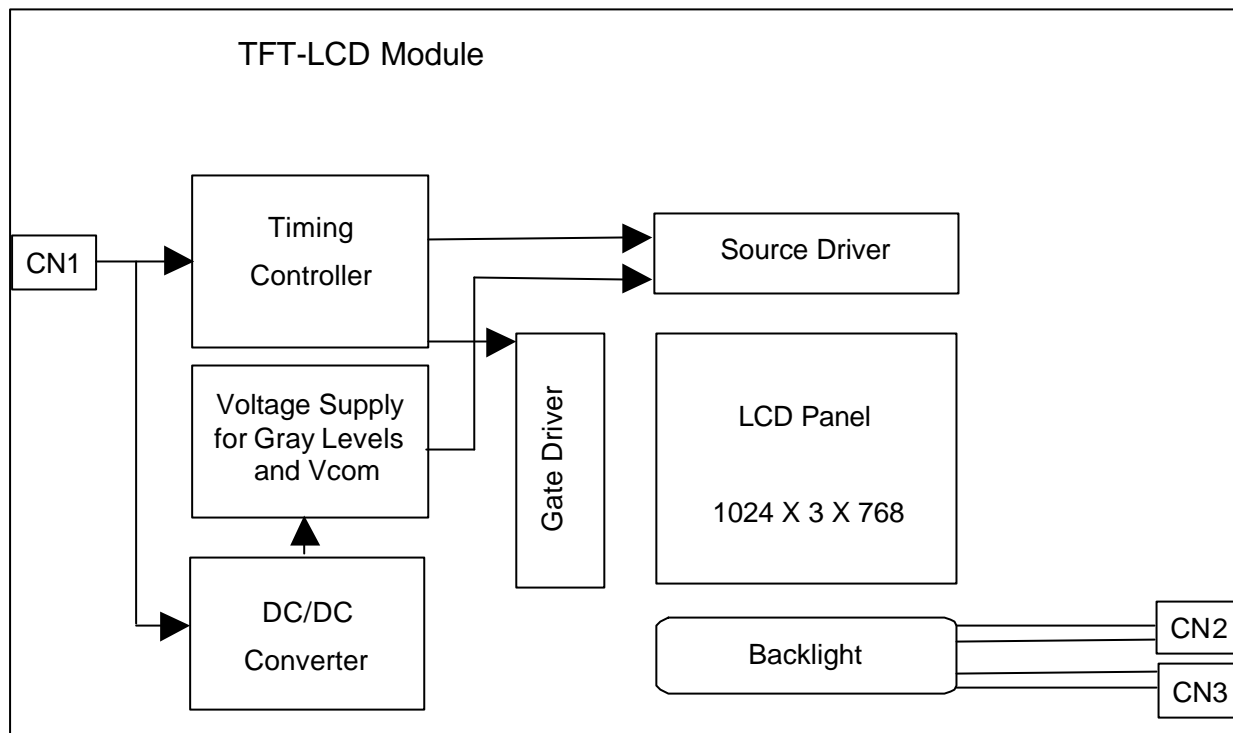

7. MECHANICAL SPECIFICATIONS

(1) Front side

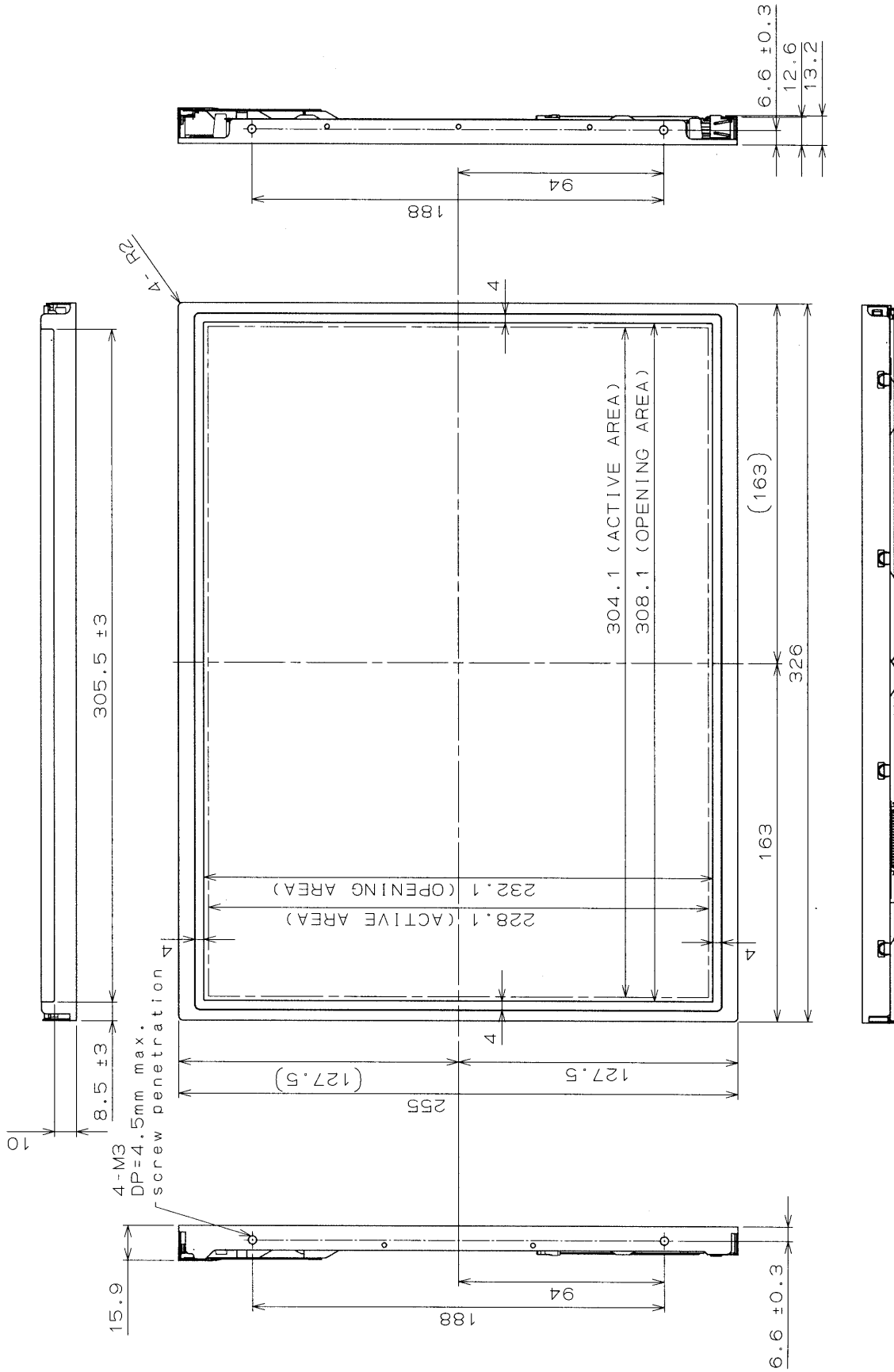

AA150XN01

- 1) Tolerance is ±0.5mm unless noted.
- 2) Except for thickness of PET film.

(2)Rear side

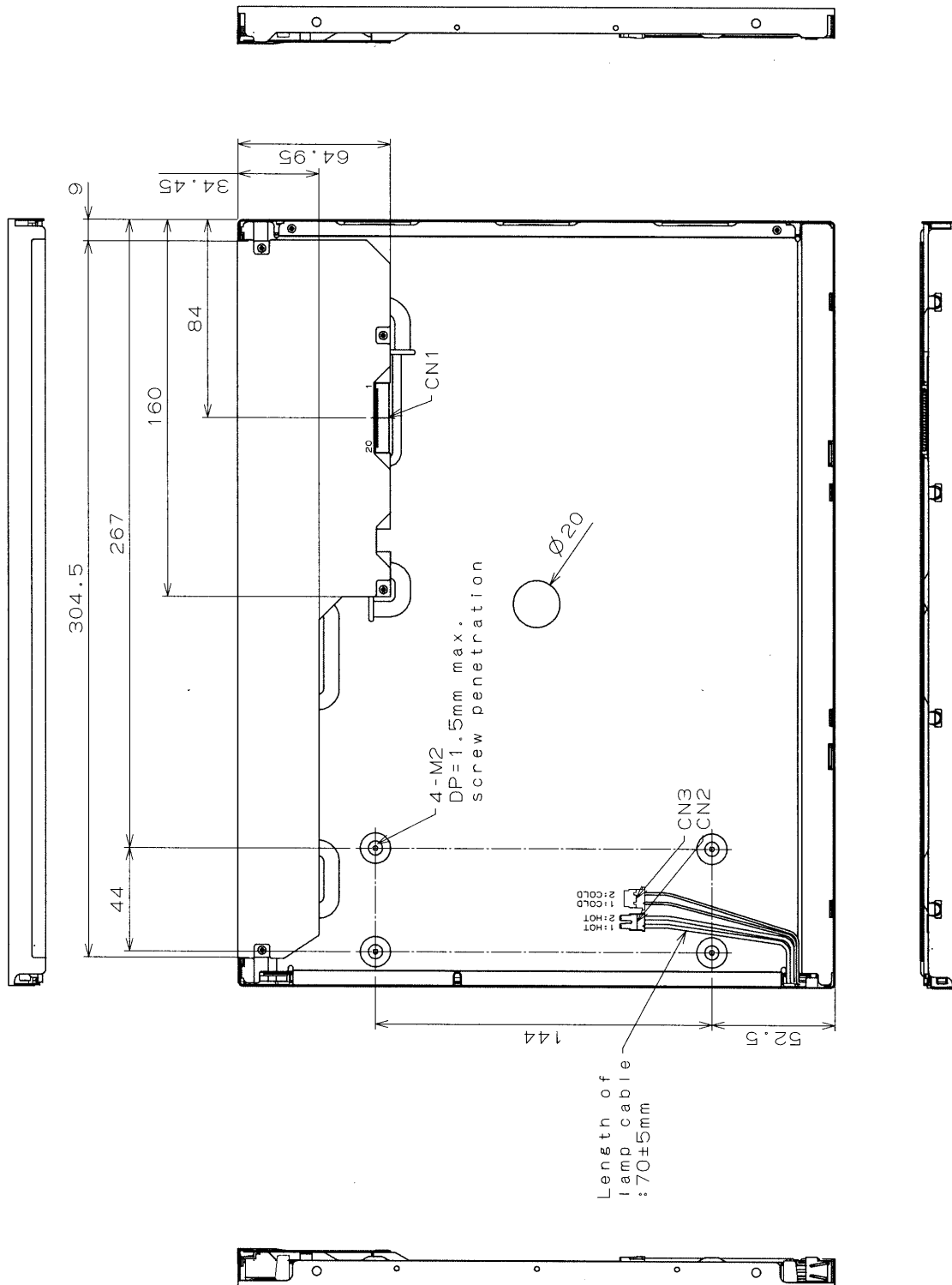

CN1: DF-14H-20P-1.25H(HIROSE)
 CN2: BHSR-02VS-1(JST)
 CN3: BHR-02VS-1(JST)

AA150XN01

1)Tolerance is ±0.5mm unless noted.
 2)Except for thickness of PET film.

[Note]

We recommend you referring to the detailed drawing for your design.
 Please contact our company sales representative when you need the detailed drawing.

8. OPTICAL CHARACTERISTICS

Ta = 25°C, VCC = 3.3 V, Input Signals: Typ. Values shown in Section 5

ITEM	SYMBOL	CONDITION	MIN.	TYP.	MAX.	UNIT	Remarks		
Contrast Ratio	CR	$\theta = \phi = 0^\circ$	300	450	--	--	*1)*3)		
Luminance	Normal	$\theta = \phi = 0^\circ$	200	250	--	cd/m ²	*2)*3)		
	Uniformity	ΔLw	--	--	30	%	*2)*3)		
Response Time	tr	$\theta = \phi = 0^\circ$	--	6	--	ms	*3)*4)		
	tf	$\theta = \phi = 0^\circ$	--	19	--	ms	*3)*4)		
Viewing Angle	Horizontal	ϕ	CR ≥ 10		--	-75~75	--	°	*3)
	Vertical	θ	CR ≥ 10		--	-60~50	--	°	*3)
	Horizontal	ϕ	CR ≥ 5		--	-80~80	--	°	*3)
	Vertical	θ	CR ≥ 5		--	-80~70	--	°	*3)
Image Sticking	tis	2 h	--	--	2	s	*5)		
Color Coordinates	Red	Rx	$\theta = \phi = 0^\circ$	--	(0.597)	--	--	*3)	
		Ry		--	(0.343)	--			
	Green	Gx		--	(0.316)	--			
		Gy		--	(0.566)	--			
	Blue	Bx		--	(0.153)	--			
		By		--	(0.131)	--			
	White	Wx		--	(0.303)	--			
		Wy		--	(0.313)	--			

[Note]

These items are measured using CS1000(MINOLTA) for color coordinates, EZContrast(ELDIM) for viewing angle, and CS1000 or BM-5A(TOPCON) for others under the dark room condition (no ambient light) after more than 30 minutes from turning on the lamp unless noted.

Condition: IL = 6.5 mArms, Inverter frequency: 60 kHz

*1) Definition of Contrast Ratio

CR=ON(White) Luminance / OFF(Black) Luminance: point 5 shown in a figure below

*2) Definition of Luminance and Luminance Uniformity

Lw=ON (White) Luminance: point 5 shown in a figure below

$\Delta Lw = [Lw(\text{MAX})/Lw(\text{MIN}) - 1] \times 100$

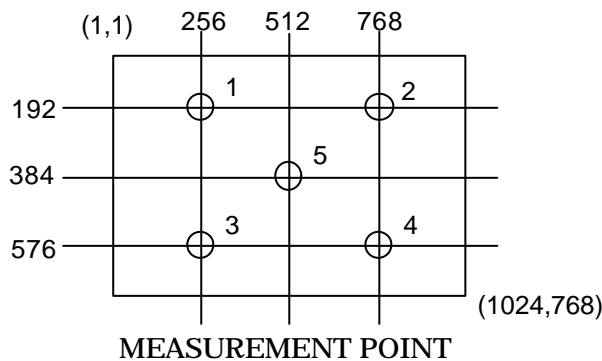

***3) Definition of Viewing Angle(θ , ϕ)**

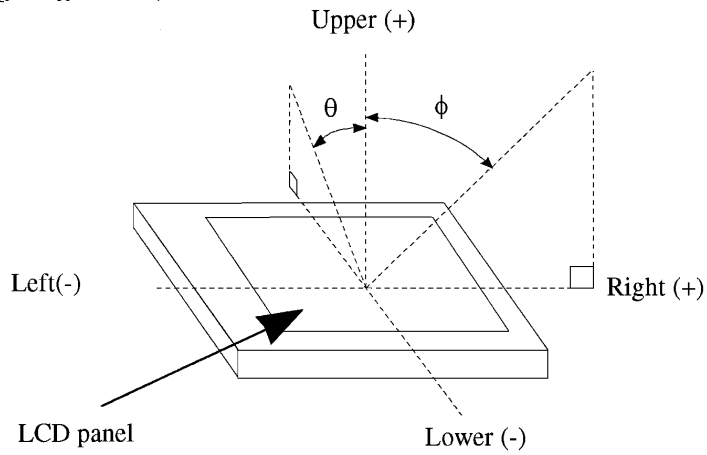

***4) Definition of Response Time**

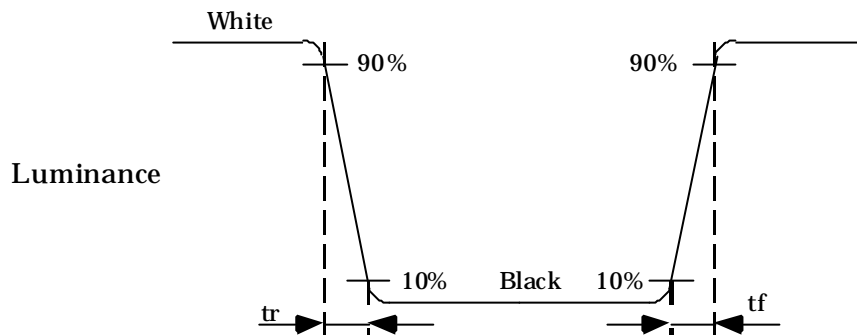

***5) Image Sticking**

Continuously display the test pattern shown in the figure below for two-hours. Then display a completely white screen. The previous image shall not persist more than two seconds at 25°C.

Cols 510-514

Rows 382-386

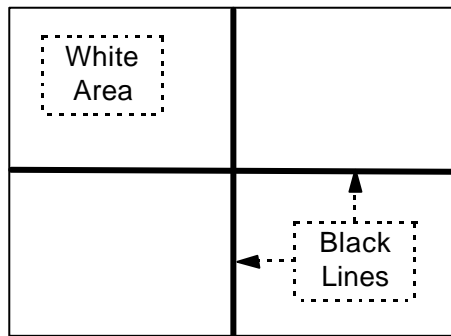

TEST PATTERN FOR IMAGE STICKING TEST

9. RELIABILITY TEST CONDITION

(1) Temperature and Humidity

TEST ITEM	CONDITIONS
HIGH TEMPERATURE HIGH HUMIDITY OPERATION	40°C, 90% RH, 240 h (No condensation)
HIGH TEMPERATURE OPERATION	50°C, 240 h
LOW TEMPERATURE OPERATION	0°C, 240 h
THERMAL SHOCK (Non-Operation)	BETWEEN -20°C (1h) and 60°C(1h), 5 CYCLES
HIGH TEMPERATURE STORAGE	60°C, 240 h
LOW TEMPERATURE STORAGE	-20°C, 240 h

(2) Shock & Vibration

ITEM	CONDITIONS
SHOCK (NON-OPERATION)	Shock level: 980 m/s ² (100 G) Waveform: half sinusoidal wave, 2 ms Number of shocks: one shock input in each direction of three mutually Perpendicular axes for a total of six shock inputs
VIBRATION (NON-OPERATION)	Vibration level: 9.8 m/s ² (1.0 G) zero to peak Waveform: sinusoidal Frequency range: 5 to 500 Hz Frequency sweep rate: 0.5 octave /min Duration: one sweep from 5 to 500 Hz in each of three mutually perpendicular axis(each x,y,z axis: 1 hour, total 3 hours)

(3) Judgment standard

The judgment of the above tests should be made as follow:

Pass: Normal display image with no obvious non-uniformity and no line defect.

Partial transformation of the module parts should be ignored.

Fail: No display image, obvious non-uniformity, or line defects.

10. HANDLING PRECAUTIONS FOR TFT-LCD MODULE

Please pay attention to the followings in handling TFT-LCD products;

(1) ASSEMBLY PRECAUTION

- a. Please mount the LCD module by using mounting hole with a screw clamping torque less than 0.5 Nm. Please do not bend or wrench the LCD module in assembling. Please do not drop, bend or twist the LCD module in handling. Please mount the inverter circuit board by using mounting hole of rear side with a screw clamping torque less than 0.2 Nm.
- b. Please design display housing in accordance with the following guide lines.
 - (a) Housing case must be designed carefully so as not to put stresses on LCD all sides and not to wrench module. The stresses may cause non-uniformity even if there is no non-uniformity statically.
 - (b) Keep sufficient clearance between LCD module back surface and housing when the LCD module is mounted. Approximately 1.0mm of the clearance in the design is recommended taking into account the tolerance of LCD module thickness and mounting structure height on the housing.
 - (c) When some parts, such as, FPC cable and ferrite plate, are installed underneath the LCD module, still sufficient clearance is required, such as 0.5mm. This clearance is, especially, to be reconsidered when the additional parts are implemented for EMI countermeasure.
 - (d) Design the inverter location and connector position carefully so as not to give stress to lamp cable, or not to interface the LCD module by the lamp cable.
 - (e) Keep sufficient clearance between LCD module and the others parts, such as inverter and speaker so as not to interface the LCD module. Approximately 1.0mm of the clearance in the design is recommended.
- c. Please do not push or scratch LCD panel surface with anything hard. And do not soil LCD panel surface by touching with bare hands. (Polarizer film, surface of LCD panel is easy to be flawed.)
- d. Please do not press any parts on the rear side such as source TCP, gate TCP, control circuit board and FPCs during handling LCD module. If pressing rear part is unavoidable, handle the LCD module with care not to damage them.
- e. Please wipe off LCD panel surface with absorbent cotton or soft cloth in case of it being soiled.
- f. Please wipe off drops of adhesives like saliva and water on LCD panel surface immediately. They might damage to cause panel surface variation and color change.
- g. Please do not take a LCD module to pieces and reconstruct it. Resolving and reconstructing modules may cause them not to work well.
- h. Please do not touch metal frames with bare hands and soiled gloves. A color change of the metal frames can happen during a long preservation of soiled LCD modules.
- i. Please pay attention to handling lead wire of backlight so that it is not tugged in connecting with inverter.
- j. Please connect the metal frame of LCD module to GND in order to minimize the effect of external

noise and EMI.

k. Be sure to connect the cables and the connectors correctly.

(2) OPERATING PRECAUTIONS

- a. Please be sure to turn off the power supply before connecting and disconnecting signal input cable.
- b. Please do not change variable resistance settings in LCD module. They are adjusted to the most suitable value. If they are changed, it might happen LCD does not satisfy the characteristics specification.
- c. LCD backlight takes longer time to become stable of radiation characteristics in low temperature than in room temperature.
- d. The interface signal speed is very high. Please pay attention to transmission line design and other high speed signal precautions to satisfy signal specification.
- e. A condensation might happen on the surface and inside of LCD module in case of sudden change of ambient temperature.
- f. Please pay attention not to display the same pattern for very long time. Image might stick on LCD. Even if image sticking happens, it may disappear as the operation time proceeds.
- g. Please obey the same safe instructions as ones being prepared for ordinary electronic products.

(3) PRECAUTIONS WITH ELECTROSTATICS

- a. This LCD module use CMOS-IC on circuit board and TFT-LCD panel, and so it is easy to be affected by electrostatics. Please be careful with electrostatics by the way of your body connecting to the ground and so on.
- b. Please remove protection film very slowly from the surface of LCD module to prevent from electrostatics occurrence.

(4) STORAGE PRECAUTIONS

- a. Please do not leave the LCDs in the environment of high humidity and high temperature such as 60°C90% RH.
- b. Please do not leave the LCDs in the environment of low temperature; below -20°C.

(5) SAFETY PRECAUTIONS

- a. When you waste damaged or unnecessary LCDs, it is recommended to crush LCDs into pieces and wash them off with solvents such as acetone and ethanol, which should later be burned.

- b. If any liquid leaks out of a damaged glass cell and comes in contact with the hands, wash off thoroughly with soap and water.
- c. Be sure to turn off the power supply when inserting or disconnecting the cable.
- d. Inverter should be designed carefully so as not to keep working in case of detecting over current or open circuit on the lamp.

(6) OTHERS

- a. A strong incident light into LCD panel might cause display characteristics changing inferior because of polarizer film, color filter, and other materials becoming inferior. Please do not expose LCD module direct sunlight and strong UV rays.
- b. Please pay attention to a panel side of LCD module not to contact with other materials in preserving it alone.
- c. For the packaging box, please pay attention to the followings;
 - (a) Packaging box and inner case for LCD are designed to protect the LCDs from the damage or scratching during transportation. Please do not open except picking LCDs up from the box.
 - (b) Please do not pile them up more than 5 boxes. (They are not designed so.) And please do not turn over.
 - (c) Please handle packaging box with care not to give them sudden shock and vibrations. And also please do not throw them up.
 - (d) Packaging box and inner case for LCDs are made of cardboard. So please pay attention not to get them wet. (Such like keeping them in high humidity or wet place can occur getting them wet.)