

LCD Module Technical Specification

First Edition
Jun 18, 2003

Final Revision

Type No. **T-51512D121J-FW-A-AB**

I. Sato

Approved by (Quality Assurance Division)

Shuichi Iida

Checked by (ACI Engineering Division)

R. Wajuri

Prepared by (Module Administration Group)

No.	Item	Page
--	CONTENTS	1
1	OVERVIEW	2
2	ABSOLUTE MAXIMUM RATINGS	3
3	ELECTRICAL CHARACTERISTICS	3
4	INTERFACE PIN CONNECTION	6
5	INTERFACE TIMING	8
6	BLOCK DIAGRAM	11
7	MECHANICAL SPECIFICATION	12
8	OPTICAL CHARACTERISTICS	14
9	RELIABILITY TEST CONDITION	16
10	INSPECTION STANDARDS	17
11	HANDLING PRECAUTIONS FOR TFT-LCD MODULE	18
--	PACKAGING SPECIFICATION	21
--	PRODUCT NUMBER LABELING FORMS	25
--	LAMP UNIT FOR 12.1" SVGA	27

1. OVERVIEW

T-51512D121J-FW-A-AB is 12.1" color TFT-LCD (Thin Film Transistor Liquid Crystal Display) module composed of LCD panel, driver ICs, control circuit, and backlight unit.

By applying 6 bit digital data, 800×600 , 260 K-color images are displayed on the 12.1" diagonal screen. Input power voltage is single 3.3V or 5.0V for LCD driving. Both 3.3 V-CMOS and 5.0 V-CMOS level voltage are acceptable for logic input voltage.

Inverter for backlight is not included in this module. General specifications are summarized in the following table:

ITEM	SPECIFICATION
Display Area (mm)	246.0 × 184.5 (12.106-inch diagonal)
Number of Dots	800 × 3 (H) × 600 (V)
Pixel Pitch (mm)	0.3075 (H) × 0.3075 (V)
Color Pixel Arrangement	RGB vertical stripe
Display Mode	normally white
Number of Color	260 K
Optimum Viewing Angle(Contrast ratio)	6 o'clock
Brightness (cd/m ²)	350
Module Size (mm)	280.0 (W) × 210.0 (H) × 12.0 (D)
Module Mass (g)	720
Backlight Unit	CCFL, 2-tubes, edge-light, replaceable
Surface Treatment	Antiglare and hard-coating 3H

Characteristic value without any note is typical value.

The LCD product described in this specification is designed and manufactured for the standard use in OA equipment and consumer products, such as computers, communication equipment, industrial robots, AV equipment and so on.

Do not use the LCD product for the equipment that require the extreme high level of reliability, such as aerospace applications, submarine cables, nuclear power control systems and medical or other equipment for life support.

OPTREX assumes no responsibility for any damage resulting from the use of the LCD product in disregard of the conditions and handling precautions in this specification.

If customers intend to use the LCD product for the above items or other no standard items, please contact our sales persons in advance.

2. ABSOLUTE MAXIMUM RATINGS

ITEM	SYMBOL	MIN.	MAX	UNIT
Power Supply Voltage for LCD	VCC	0	6.0	V
Logic Input Voltage	VI	0	6.5	V
Lamp Voltage	VL	0	2000	Vrms
Lamp Current	IL	0	18	mArms
Lamp Frequency	FL	---	80	kHz
Operation Temperature Note 1,2)	T _{op}	0	60	°C
Storage Temperature Note 2)	T _{stg}	-20	70	°C

[Note]

1) Display panel surface

2) Top,Tstg ≤ 40°C : 90%RH max. without condensation

Top,Tstg > 40°C : Absolute humidity shall be less than the value of 90%RH at 40°C without condensation.

3. ELECTRICAL CHARACTERISTICS

(1) TFT-LCD

Ambient temperature: Ta = 25

ITEM	SYMBOL	MIN.	TYP.	MAX.	UNIT	Remarks	
Power Supply Voltage for LCD	3.3V powered	VCC	3.0	3.3	3.6	V	A)
	5.0V powered	VCC	4.75	5.0	5.25	V	A)
Power Supply Current for LCD	3.3V powered	ICC	--	340	500	mA	VCC = 3.3 V B)
	5.0V powered	ICC	--	220	340	mA	VCC = 5.0 V B)
Permissive Input Ripple Voltage	VRP	--	--	100	mVp-p	VCC = +3.3V/5.0V	
Logic Input Voltage	High	VIH	2.0	--	5.25	V	
	Low	VIL	0	--	0.8	V	

(2) Backlight

Ta = 25

ITEM	SYMBOL	MIN.	TYP.	MAX.	UNIT	Remarks
Lamp Voltage	VL	--	540	--	Vrms	IL = 12.0 mArms
Lamp Current	IL	6.0	12.0	13.0	mArms	Note 1), 5)
Lamp Frequency	FL	30	--	60	kHz	Note 2)
Starting Lamp Voltage	VS	1000	--	--	Vrms	Ta = 25°C Note 3)
		1200	--	--		Ta = 0°C Note 3)
Lamp Life Time	LT	50,000	--	--	h	IL = 12.0 mArms, Continuous operation Note 3),4)

VCC-dip conditions:

(a) 3.3 V powered

- 1) When $2.7\text{ V} \leq VCC < 3.0\text{ V}$, $t_d \leq 10\text{ ms}$
- 2) When $VCC < 2.7\text{ V}$

VCC-dip conditions should also follow the power and signals sequence.

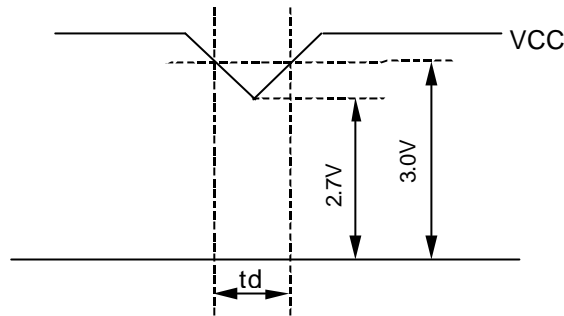

(b) 5.0V powered

- 1) When $4.2\text{ V} \leq VCC < 4.5\text{ V}$, $t_d \leq 10\text{ ms}$
- 2) When $VCC < 4.2\text{ V}$

VCC-dip conditions should also follow the power and signals sequence.

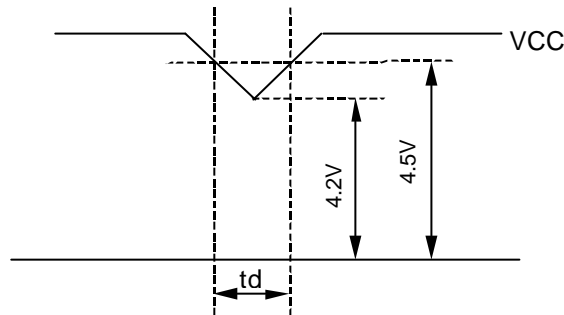

B) Typical current condition:

64-gray-bar pattern

600 line mode

$VCC = +3.3\text{ V} / 5.0\text{ V}$, $f_H=37.9\text{kHz}$, $f_V=60.3\text{Hz}$, $f_{CLK}= 40\text{MHz}$

4. INTERFACE PIN CONNECTION

CN 1(INTERFACE SIGNAL)

Used connector: DF9B-41P-1V(Hirose)

Corresponding connector: DF9B-41S-1V(Hirose)

Pin No.	Symbol	Function
1	GND	Signal ground
2	DCLK	Clock signal for sampling catch data signal
3	GND	Signal ground
4	HD	Horizontal sync signal
5	VD	Vertical sync signal
6	GND	Signal ground
7	GND	Signal ground
8	GND	Signal ground
9	R0	RED data signal(LSB)
10	R1	RED data signal
11	R2	RED data signal
12	GND	Signal ground
13	R3	RED data signal
14	R4	RED data signal
15	R5	RED data signal(MSB)
16	GND	Signal ground
17	GND	Signal ground
18	GND	Signal ground
19	G0	GREEN data signal(LSB)
20	G1	GREEN data signal
21	G2	GREEN data signal
22	GND	Signal ground
23	G3	GREEN data signal
24	G4	GREEN data signal
25	G5	GREEN data signal(MSB)
26	GND	Signal ground
27	GND	Signal ground
28	GND	Signal ground
29	B0	BLUE data signal (LSB)
30	B1	Blue data signal
31	B2	BLUE data signal
32	GND	Signal ground
33	B3	BLUE data signal
34	B4	BLUE data signal
35	B5	BLUE data signal(MSB)
36	GND	Signal ground
37	DENA	Data enable signal(to settle the viewing area)
38	NC	
39	VCC	+3.3 / 5.0 V Power supply
40	VCC	+3.3 / 5.0 V Power supply
41	SC	Scan direction control.(GND or Open:Normal, High:Reverse)

*)The shielding case is connected with GND.

CN 2(BACKLIGHT)

Backlight-side connector: BHR-04VS-1 (JST)

Inverter-side connector: SM04(4.0)B-BHS-1(JST)

Pin No.	Symbol	Function
1, 2	CTH	VBLH (High voltage)
4	CTL	VBLL (Low voltage)

VBLH - VBLL = VL

5. INTERFACE TIMING

(1) Timing Specifications

VCC = 3.3/5.0 V, Ta = 25

ITEM	SYMBOL	MIN	TYP	MAX	UNIT	
DCLK *1,4)	Frequency	f _{CLK}	35	--	40	MHz
	Period	t _{CLK}	25	--	27.8	ns
	Low Width	t _{WCL}	10	--	--	ns
	High Width	t _{WCH}	10	--	--	ns
DATA *1) (R,G,B,DENA, HD, VD)	Set up time	t _{DS}	4	--	--	ns
	Hold time	t _{DH}	4	--	--	ns
DENA *3)	Horizontal Active Time	t _{HA}	800	800	800	t _{CLK}
	Horizontal Front Porch	t _{HFP}	0	--	--	t _{CLK}
	Horizontal Back Porch	t _{HBP}	10	--	--	t _{CLK}
	Vertical Active Time	t _{VA}	600	600	600	t _H
	Vertical Front Porch	t _{VFP}	1	--	--	t _H
	Vertical Back Porch	t _{VBP}	2	--	--	t _H
HD *2,4)	Frequency	f _H	35.2	37.9	39.2	kHz
	Period	t _H	25.5	26.4	28.4	μs
	Low Width	t _{WHL}	5	--	--	t _{CLK}
VD *2)	Frequency	f _V	55	60.3	64.2	Hz
	Period	t _V	15.6	16.6	18.2	ms
	Low Width	t _{WVL}	1	--	--	t _H

[Note]

- *1) DATA is latched at fall edge of DCLK in this specification.
- *2) Polarities of HD and VD are negative in this specification.
- *3) DENA (Data Enable) should always be positive polarity as shown in the timing specification.
- *4) DCLK should appear during all invalid period, and HD should appear during invalid period of frame cycle.

(2) Timing Chart

a. Pixel Timing Chart

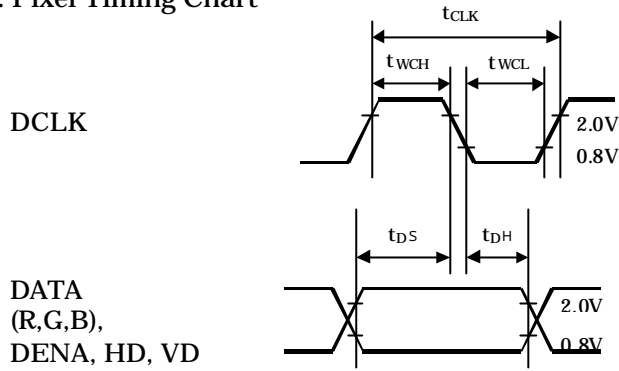

b. Horizontal Timing Chart

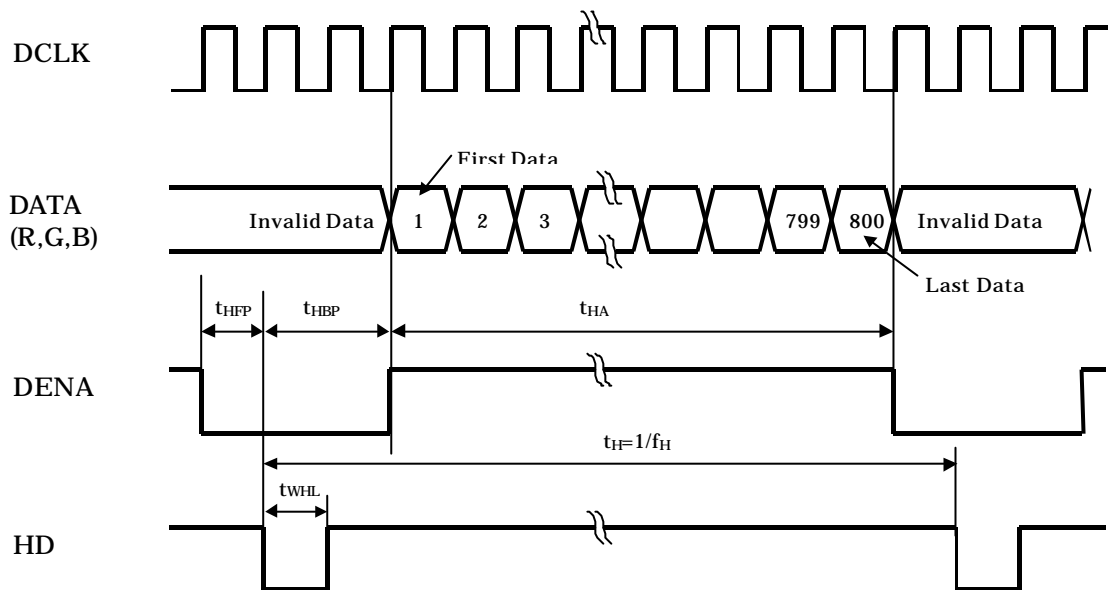

c. Vertical Timing Chart

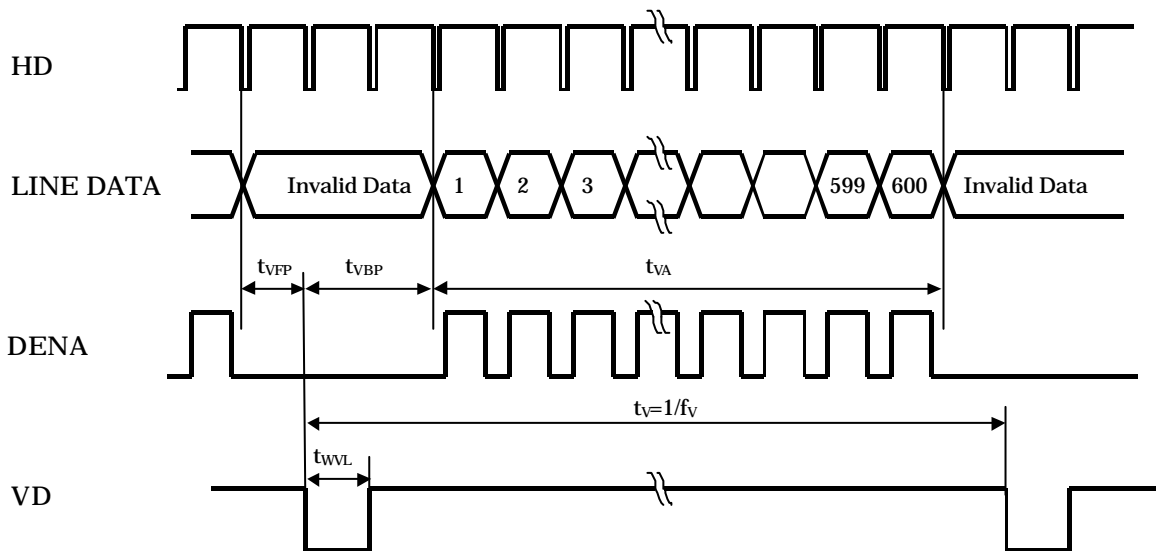

(3) Color Data Assignment

COLOR	INPUT DATA	R DATA						G DATA						B DATA					
		R5	R4	R3	R2	R1	R0	G5	G4	G3	G2	G1	G0	B5	B4	B3	B2	B1	B0
		MS					LSB	MS					LSB	MS					LSB
		B					B						B						
BASIC COLOR	BLACK	0	0	0	0	0	0	0	0	0	0	0	0	0	0	0	0	0	0
	RED(63)	1	1	1	1	1	1	0	0	0	0	0	0	0	0	0	0	0	0
	GREEN(63)	0	0	0	0	0	0	1	1	1	1	1	1	0	0	0	0	0	0
	BLUE(63)	0	0	0	0	0	0	0	0	0	0	0	0	1	1	1	1	1	1
	CYAN	0	0	0	0	0	0	1	1	1	1	1	1	1	1	1	1	1	1
	MAGENTA	1	1	1	1	1	1	0	0	0	0	0	0	1	1	1	1	1	1
	YELLOW	1	1	1	1	1	1	1	1	1	1	1	1	0	0	0	0	0	0
	WHITE	1	1	1	1	1	1	1	1	1	1	1	1	1	1	1	1	1	1
RED	RED(0)	0	0	0	0	0	0	0	0	0	0	0	0	0	0	0	0	0	0
	RED (1)	0	0	0	0	0	1	0	0	0	0	0	0	0	0	0	0	0	0
	RED(2)	0	0	0	0	1	0	0	0	0	0	0	0	0	0	0	0	0	0
	RED (62)	1	1	1	1	1	0	0	0	0	0	0	0	0	0	0	0	0	0
	RED(63)	1	1	1	1	1	1	0	0	0	0	0	0	0	0	0	0	0	0
GREEN	GREEN(0)	0	0	0	0	0	0	0	0	0	0	0	0	0	0	0	0	0	0
	GREEN(1)	0	0	0	0	0	0	0	0	0	0	0	1	0	0	0	0	0	0
	GREEN(2)	0	0	0	0	0	0	0	0	0	0	1	0	0	0	0	0	0	0
	GREEN(62)	0	0	0	0	0	0	1	1	1	1	1	0	0	0	0	0	0	0
	GREEN(63)	0	0	0	0	0	0	1	1	1	1	1	1	0	0	0	0	0	0
BLUE	BLUE(0)	0	0	0	0	0	0	0	0	0	0	0	0	0	0	0	0	0	0
	BLUE(1)	0	0	0	0	0	0	0	0	0	0	0	0	0	0	0	0	0	1
	BLUE(2)	0	0	0	0	0	0	0	0	0	0	0	0	0	0	0	0	1	0
	BLUE(62)	0	0	0	0	0	0	0	0	0	0	0	0	1	1	1	1	1	0
	BLUE(63)	0	0	0	0	0	0	0	0	0	0	0	0	1	1	1	1	1	1

[Note]1) Definition of gray scale

Color (n) --- n indicates gray scale level.

Higher n means brighter level.

2) Data 1:High, 0: Low

6. BLOCK DIAGRAM

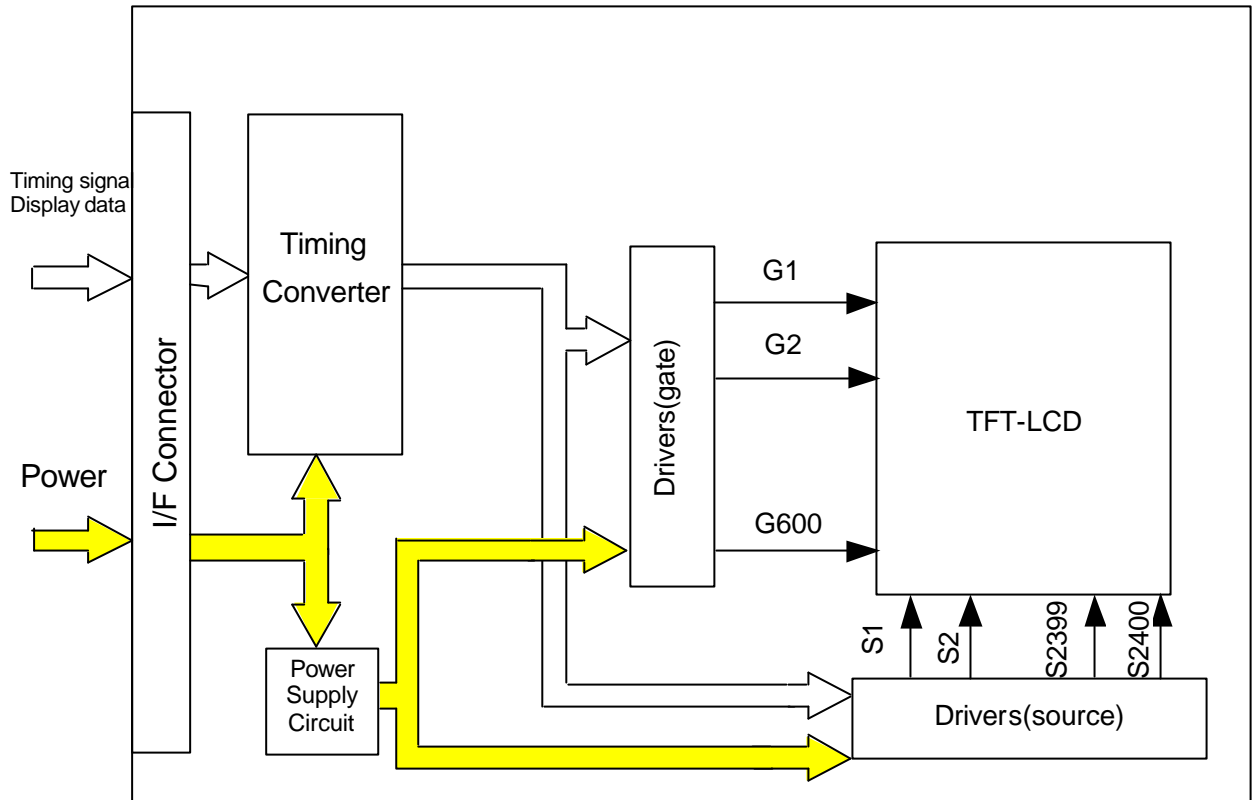

BACKLIGHT

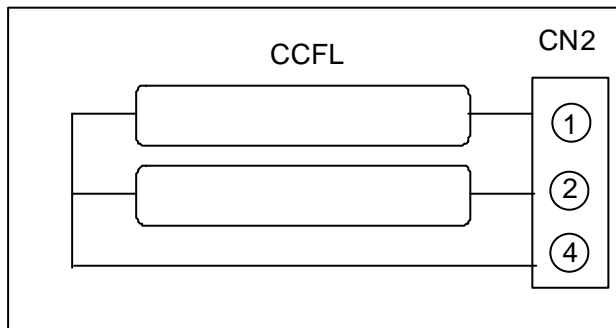

7. MECHANICAL SPECIFICATIONS

(1) Front Side

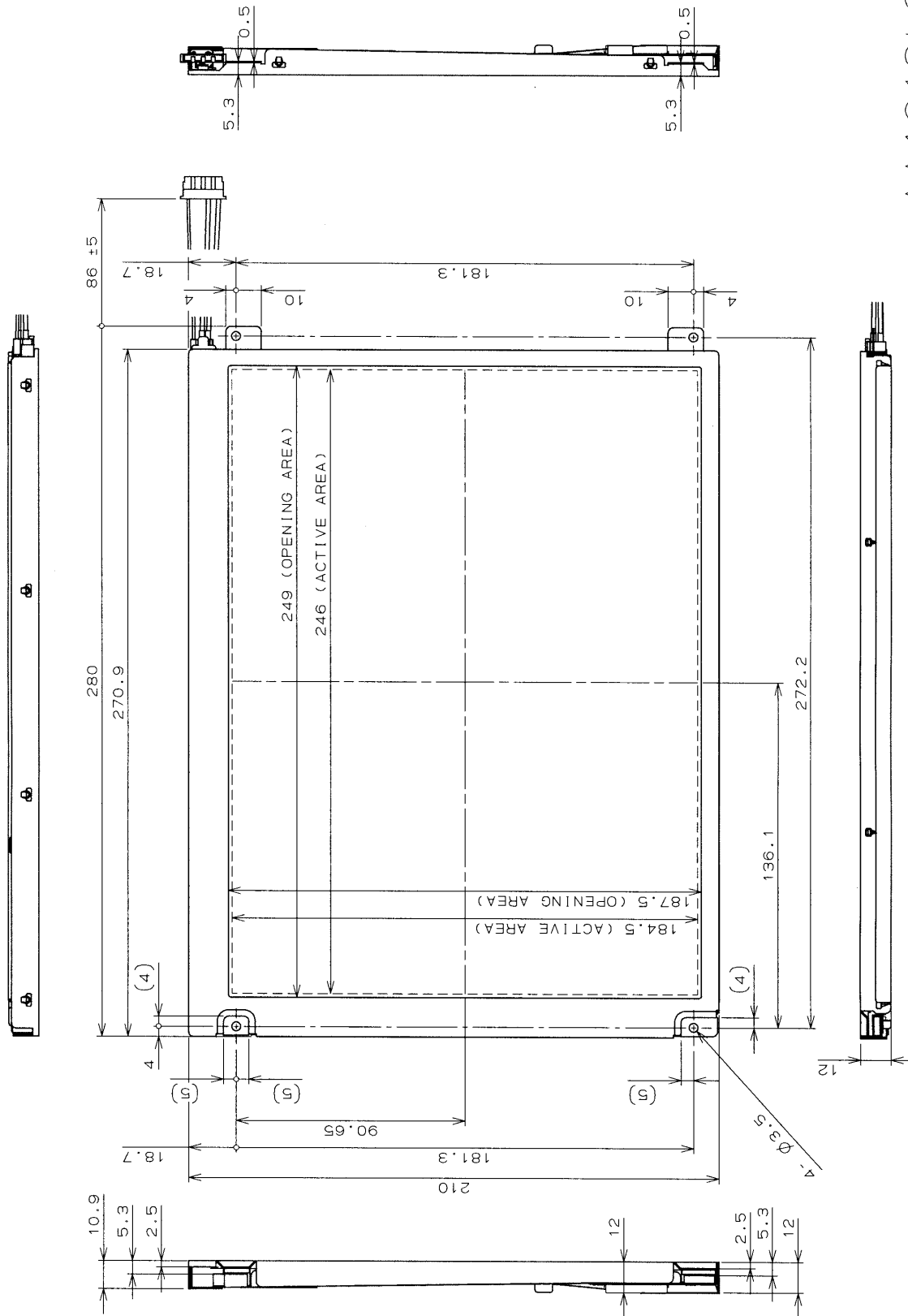

AA121SL01

UNDEFINED TOLERANCES TO BE ±0.5mm.
 EXPECT FOR THICKNESS OF PET FILM.

(Unit: mm)

(2) Rear Side

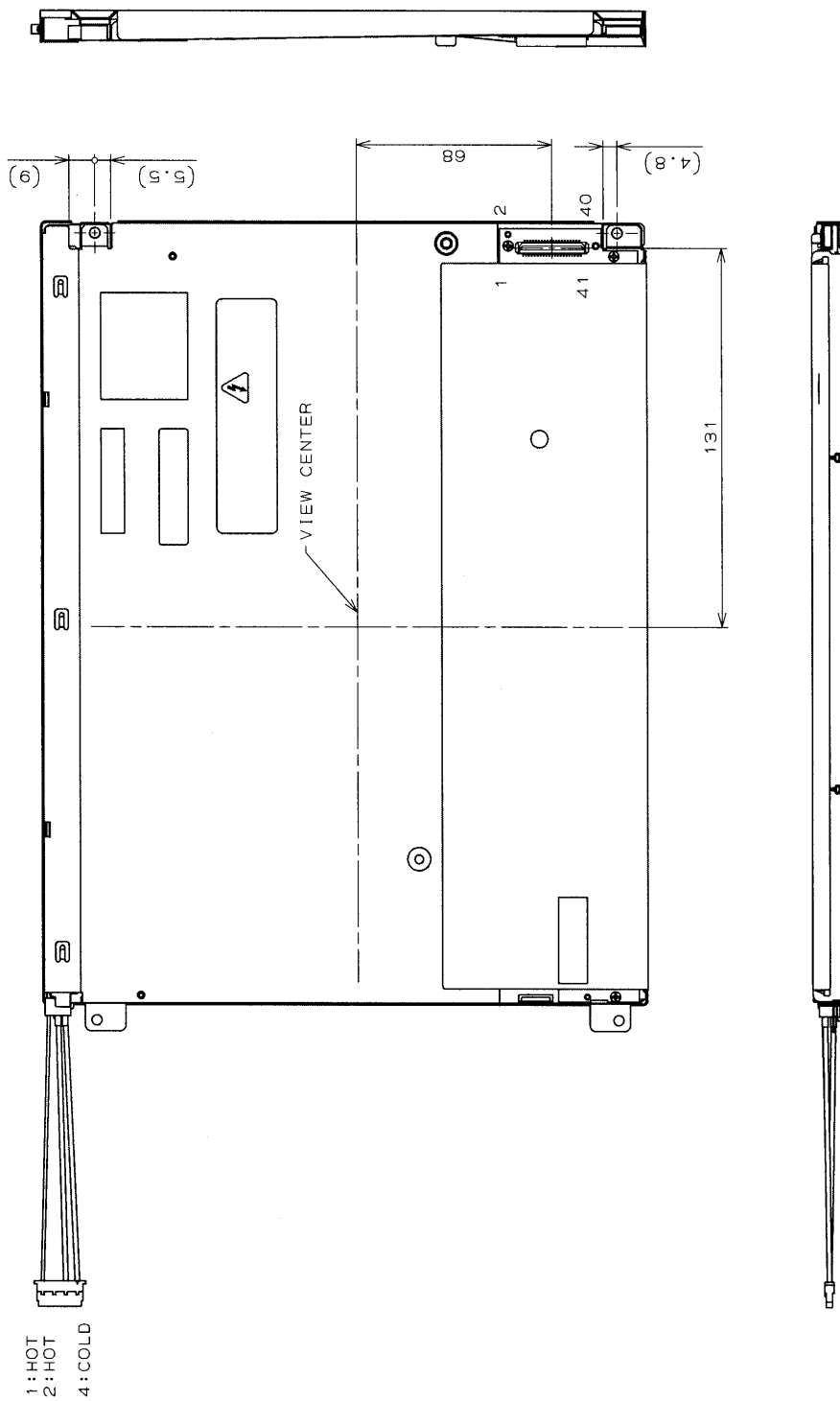

AA121SLO1
UNDEFINED TOLERANCES TO BE $\pm 0.5\text{mm}$.
EXPECT FOR THICKNESS OF PET FILM.

(Unit:mm)

[Note]

We recommend you referring to the detailed drawing for your design.
Please contact our company sales representative when you need the detailed drawing.

T-51512D121J-FW-A-AB (AB) No. 2003-0101	OPTREX CORPORATION	Page 13/32
---	--------------------	------------

8. OPTICAL CHARACTERISTICS

Ta=25°C, VCC=3.3V / 5.0V, Input Signals: Typ. Values shown in Section 5

ITEM		SYMBOL	CONDITION	MIN	TYP	MAX	UNIT	Remarks
Contrast Ratio		CR	$\theta = \phi = 0^\circ$	350	500	--	--	*1)*3)
Luminance		Lw	$\theta = \phi = 0^\circ$	250	350	--	cd/m ²	*2)*3)
Response Time		tr	$\theta = \phi = 0^\circ$	--	10	--	ms	*3)*4)
		tf	$\theta = \phi = 0^\circ$	--	30	--	ms	*3)*4)
Viewing Angle	Horizontal	ϕ	CR \geq 10	-50~50	-60~60	--	°	*3)
	Vertical	θ		-40~30	-50~40	--	°	*3)
Image sticking		tis	2 h	--	--	2	s	*5)
Color Coordinates	Red	Rx	$\theta = \phi = 0^\circ$	0.556	0.586	0.616	--	*3)
		Ry		0.310	0.340	0.370		
	Green	Gx		0.300	0.330	0.360		
		Gy		0.525	0.555	0.585		
	Blue	Bx		0.138	0.168	0.198		
		By		0.167	0.197	0.227		
	White	Wx		0.302	0.332	0.362		
		Wy		0.337	0.367	0.397		

[Note]

These items are measured using CS1000(MINOLTA) for color coordinates, EZContrast(ELDIM) for viewing angle and CS1000 or BM-5A(TOPCON) for others under the dark room condition (no ambient light) after more than 30 minutes from turning on the lamp unless noted.

Condition: IL = 12.0 mArms, FL=55kHz

*1) Definition of Contrast Ratio

CR=ON (White) Luminance / OFF(Black) Luminance: average of 5 points in a figure below

*2) Definition of Luminance

Lw= ON (White) Luminance: average of 5 points in a figure below

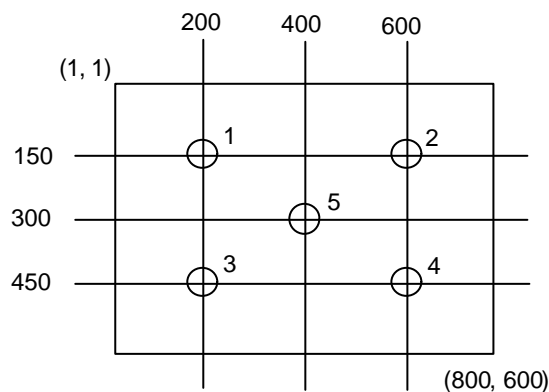

*3) Definition of Viewing Angle(θ , ϕ)

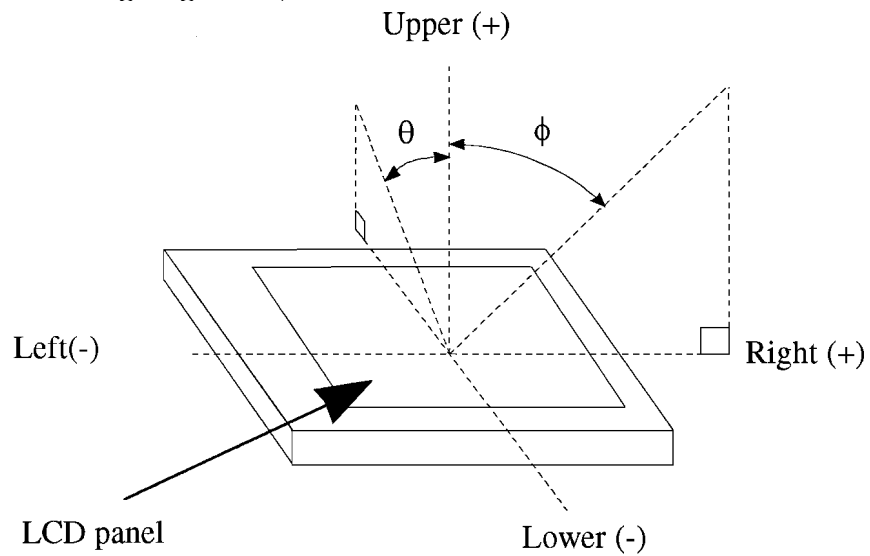

*4) Definition of Response Time

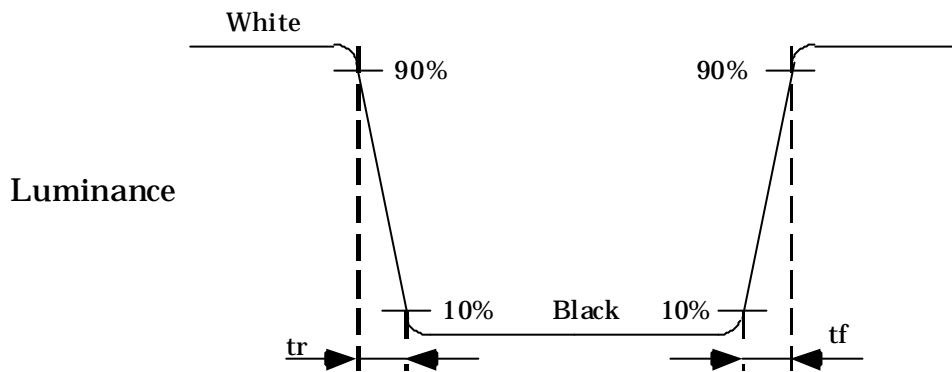

*5) Image sticking:

Continuously display the test pattern shown in the figure below for two-hours. Then display a completely white screen. The previous image shall not persist more than two seconds at 25°C.

TEST PATTERN FOR IMAGE STICKING TEST

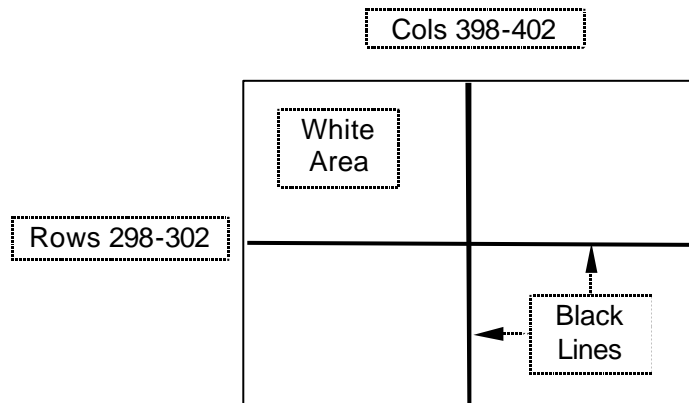

9. RELIABILITY TEST CONDITION

(1) Temperature and Humidity

TEST ITEM	CONDITIONS
HIGH TEMPERATURE HIGH HUMIDITY OPERATION	40°C, 90%RH, 240 h
HIGH TEMPERATURE STORAGE	70°C, 96 h
LOW TEMPERATURE STORAGE	-20°C, 96 h
THERMAL SHOCK	BETWEEN -20°C (1h) and 70°C(1h), 5 CYCLES

(2) Shock & Vibration

ITEM	CONDITIONS
SHOCK (NON-OPERATION)	Shock level: 1470m/s ² (150G) Waveform: half sinusoidal wave, 2ms Number of shocks: one shock input in each direction of three mutually perpendicular axes for a total of six shock inputs
VIBRATION (NON-OPERATION)	Vibration level: 9.8m/s ² (1.0G) Waveform: sinusoidal Frequency range: 5 to 500Hz Frequency sweep rate: 0.5 octave /min Duration: one sweep from 5 to 500 Hz in each of three mutually perpendicular axis(each x,y,z axis: 1 hour, total 3 hours)

(3) Judgment standard

The judgment of the above tests should be made as follow:

Pass: Normal display image with no obvious non-uniformity and no line defect.

Partial transformation of the module parts should be ignored.

Fail: No display image, obvious non-uniformity, or line defects.

10. INSPECTION STANDARDS

Inspection condition is as follows:

- Viewing distance is approximately 35 cm.
- Viewing angle is normal to the LCD panel.
- Ambient temperature is approximately 25°C.
- Ambient light is from 300 to 500 lx.

Bright Dot is defined as follows:

Visible through 5% transmission ND filter under the condition that black image (color 0) is on the display.

DEFECT TYPE		LIMIT	
VISUAL DEFECT	SCRATCH	0.01 mm < W ≤ 0.05 mm L ≤ 10 mm	N ≤ 4
		0.01 mm < W 10 mm < L	N = 0
		0.05 mm < W	N = 0
	DENT	0.2 mm < φ ≤ 0.4 mm	N ≤ 4
		0.4 mm < φ	N = 0
	BLACK SPOT BUBBLE	0.2 mm < φ ≤ 0.4 mm	N ≤ 5
		0.4 mm < φ	N = 0
	LINT	L ≤ 3 mm W ≤ 0.1 mm	N ≤ 4
		3 mm < L W ≤ 0.1 mm	N = 0
0.1 mm < W		ACCORDING TO BLACK SPOT	
ELECTRICAL DEFECT	BRIGHT DOT	N ≤ 5	
	DARK DOT	N ≤ 5	
	TOTAL DOT	N ≤ 8	
	TWO ADJACENT DOT BRIGHT DOT DARK DOT	≤ 2 PAIRS ≤ 2 PAIRS	
	THREE OR MORE ADJACENT DOT	NOT ALLOWED	
	DISTANCE BETWEEN DEFECTS BRIGHT DOT DARK DOT	≥ 15 mm ≥ 15 mm	
	LINE DEFECT	NOT ALLOWED	

*1) W: width,L: length,φ : diameter,N: number

*2) DEFINITION OF ADJACENT

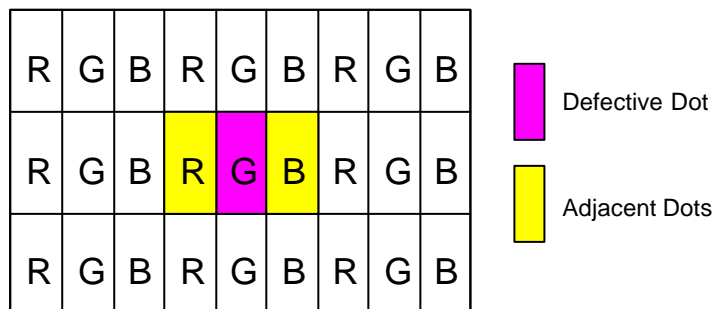

The defects that are not defined above and considered to be problem shall be reviewed and discussed by both parties.

11. HANDLING PRECAUTIONS FOR TFT-LCD MODULE

Please pay attention to the followings in handling TFT-LCD products;

(1) ASSEMBLY PRECAUTION

- a. Please use the mounting hole on the module in installing and do not bending or wrenching LCD in assembling. And please do not drop, bend or twist LCD module in handling.
- b. Please design display housing in accordance with the following guide lines.
 - (a) Housing case must be designed carefully so as not to put stresses on LCD all sides and not to wrench module. The stresses may cause non-uniformity even if there is no non-uniformity statically.
 - (b) Keep sufficient clearance between LCD module back surface and housing when the LCD module is mounted. Approximately 1.0mm of the clearance in the design is recommended taking into account the tolerance of LCD module thickness and mounting structure height on the housing.
 - (c) When some parts, such as, FPC cable and ferrite plate, are installed underneath the LCD module, still sufficient clearance is required, such as 0.5mm. This clearance is, especially, to be reconsidered when the additional parts are implemented for EMI countermeasure.
 - (d) Design the inverter location and connector position carefully so as not to give stress to lamp cable, or not to interface the LCD module by the lamp cable.
 - (e) Keep sufficient clearance between LCD module and the others parts, such as inverter and speaker so as not to interface the LCD module. Approximately 1.0mm of the clearance in the design is recommended.
- c. Please do not push or scratch LCD panel surface with anything hard. And do not soil LCD panel surface by touching with bare hands. (Polarizer film, surface of LCD panel is easy to be flawed.)
- d. Please do not press any parts on the rear side such as source TCP, gate TCP, control circuit board and FPCs during handling LCD module. If pressing rear part is unavoidable, handle the LCD module with care not to damage them.
- e. Please wipe off LCD panel surface with absorbent cotton or soft cloth in case of it being soiled.
- f. Please wipe off drops of adhesives like saliva and water on LCD panel surface immediately. They might damage to cause panel surface variation and color change.
- g. Please do not take a LCD module to pieces and reconstruct it. Resolving and reconstructing modules may cause them not to work well.
- h. Please do not touch metal frames with bare hands and soiled gloves. A color change of the metal frames can happen during a long preservation of soiled LCD modules.
- i. Please handle metal frame carefully to avoid getting hurt because edge of metal frame is very sharp.

- j. Please pay attention to handling lead wire of backlight so that it is not tugged in connecting with inverter.
- k. Be sure to connect the cables and the connectors correctly.
- l. Please connect the metal frame of LCD module to GND in order to minimize the effect of external noise and EMI.

(2) OPERATING PRECAUTIONS

- a. Please be sure to turn off the power supply before connecting and disconnecting signal input cable.
- b. Please do not change variable resistance settings in LCD module. They are adjusted to the most suitable value. If they are changed, it might happen LCD does not satisfy the characteristics specification.
- c. LCD backlight takes longer time to become stable of radiation characteristics in low temperature than in room temperature.
- d. The interface signal speed is very high. Please pay attention to transmission line design and other high speed signal precautions to satisfy signal specification.
- e. A condensation might happen on the surface and inside of LCD module in case of sudden change of ambient temperature.
- f. Please pay attention not to display the same pattern for very long time. Image might stick on LCD. Even if image sticking happens, it may disappear as the operation time proceeds.
- g. Please obey the same safe instructions as ones being prepared for ordinary electronic products.

(3) PRECAUTIONS WITH ELECTROSTATICS

- a. This LCD module use CMOS-IC on circuit board and TFT-LCD panel, and so it is easy to be affected by electrostatics. Please be careful with electrostatics by the way of your body connecting to the ground and so on.
- b. Please remove protection film very slowly from the surface of LCD module to prevent from electrostatics occurrence.

(4) STORAGE PRECAUTIONS

- a. Please do not leave the LCDs in the environment of high humidity and high temperature such as 60°C90%RH.
- b. Please do not leave the LCDs in the environment of low temperature; below -20°C.

(5) SAFETY PRECAUTIONS

- a. When you waste damaged or unnecessary LCDs, it is recommended to crush LCDs into pieces and wash them off with solvents such as acetone and ethanol, which should later be burned.
- b. If any liquid leaks out of a damaged glass cell and comes in contact with the hands, wash off thoroughly with soap and water.
- c. Be sure to turn off the power supply when inserting or disconnecting the cable.
- d. Inverter should be designed carefully so as not to keep working in case of detecting over current or open circuit on the lamp.

(6) OTHERS

- a. A strong incident light into LCD panel might cause display characteristics changing inferior because of polarizer film, color filter, and other materials becoming inferior. Please do not expose LCD module direct sunlight and strong UV rays.
- b. Please pay attention to a panel side of LCD module not to contact with other materials in preserving it alone.
- c. For the packaging box, please pay attention to the followings;
 - (a) Packaging box and inner case for LCD are designed to protect the LCDs from the damage or scratching during transportation. Please do not open except picking LCDs up from the box.
 - (b) Please do not pile them up more than 5 boxes. (They are not designed so.) And please do not turn over.
 - (c) Please handle packaging box with care not to give them sudden shock and vibrations. And also please do not throw them up.
 - (d) Packaging box and inner case for LCDs are made of cardboard. So please pay attention not to get them wet. (Such like keeping them in high humidity or wet place can occur getting them wet.)

Packaging specification

1. Packaging box

material:	cardboard, polyethylene form(Anti-electrostatic spec.)
construction:	See fig. 1
max. packaging number:	10 pcs.
dimension:	451 (W) × 413 (D) × 381 (H) [mm]
mass(including 10 modules):	10.0 kg
label:	Labels are put on the box.(See fig. 2, 3, 4)

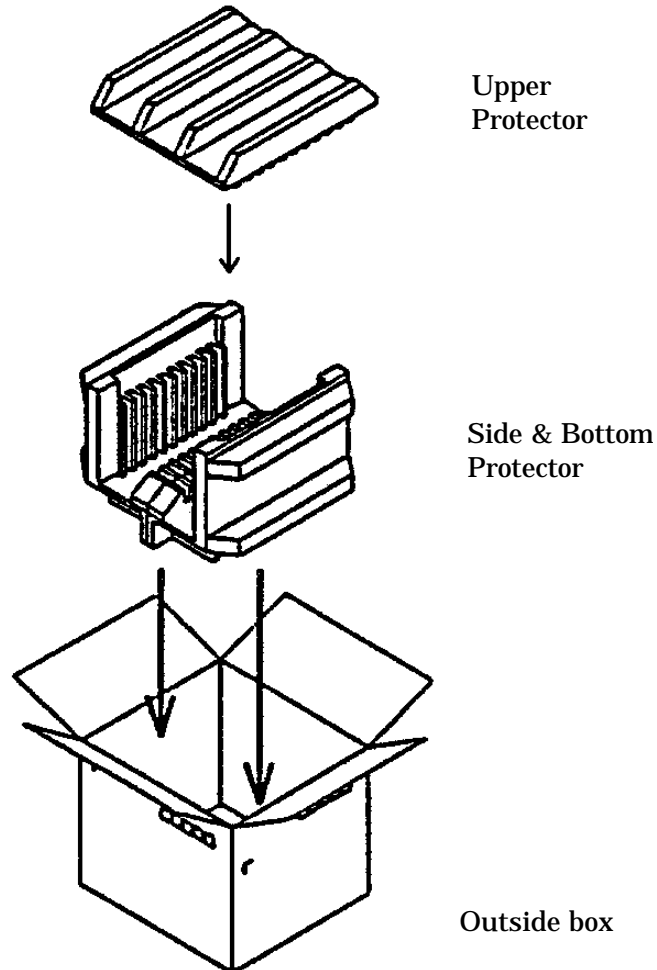

Fig. 1. Illustration of packaging box structure

Product name	Packaging number
Bar-code	Bar-code
Serial No.	Serial No.
Bar-code	Bar-code
Serial No.	Serial No.
Bar-code	Bar-code
Serial No.	Serial No.
Bar-code	Bar-code
Serial No.	Serial No.
Bar-code	Bar-code
Serial No.	Serial No.
Bar-code	Bar-code

Fig.2. Label1

Shipper	Box No.
	Mass
Shipping No.	
Bar-code	
Products name	
Bar-code	
Packaging No.	
Bar-code	
Order No.	
Bar-code	
Product name	
Bar-code	

Fig.3. Label 2

Consignee
Product name
Product name of consignee
Order No.
Box No.
Place of production
Bar-code
Shipping date

Fig. 4. Label 3



OPTREX
TFT - LCD : AA121SL01
T-51512D121J-FW-A-AB
P / O NO. 123456789
C / S 001 OF 005
MADE IN JAPAN
 01
2001/11/15
JA1BK4144

Fig. 5 Sample of Label3

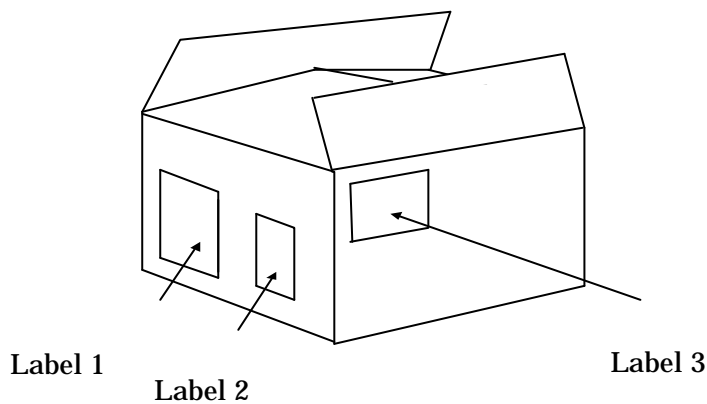

Fig. 6. Location of Labels

2. Location of label on the packaging box

- Labels are put on the box.(See Fig.6)

3. Packaging form of product

- Each of LCD module is packed in anti-electrostatic bag(Fig. 7)
- Packed LCD module is put in the packaging box.(Fig. 8)
- The packaging box accumulates maximum 10 modules.
- Upper protector is put on the products and shut the box.(Fig. 9)

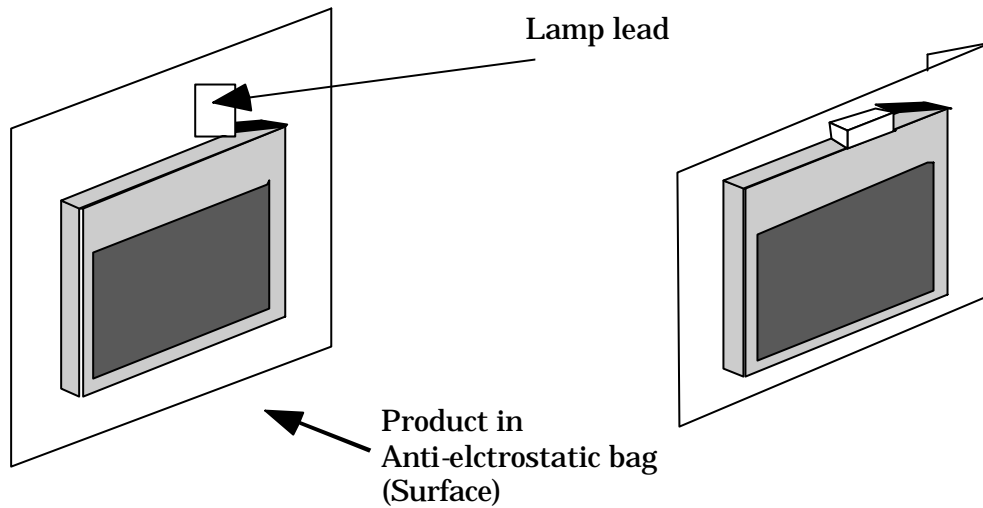

Fig. 7

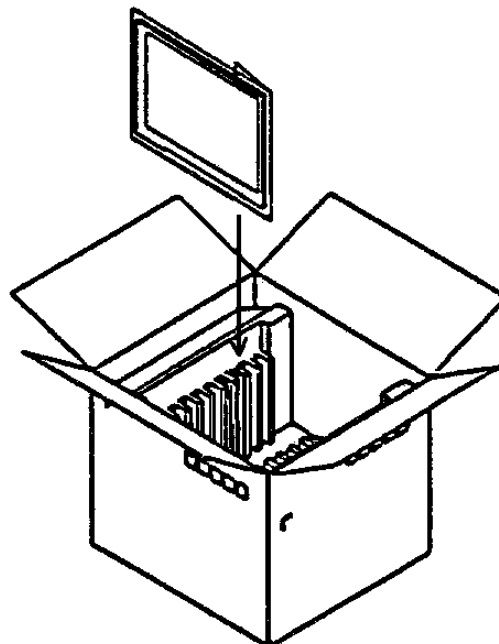

Fig. 8

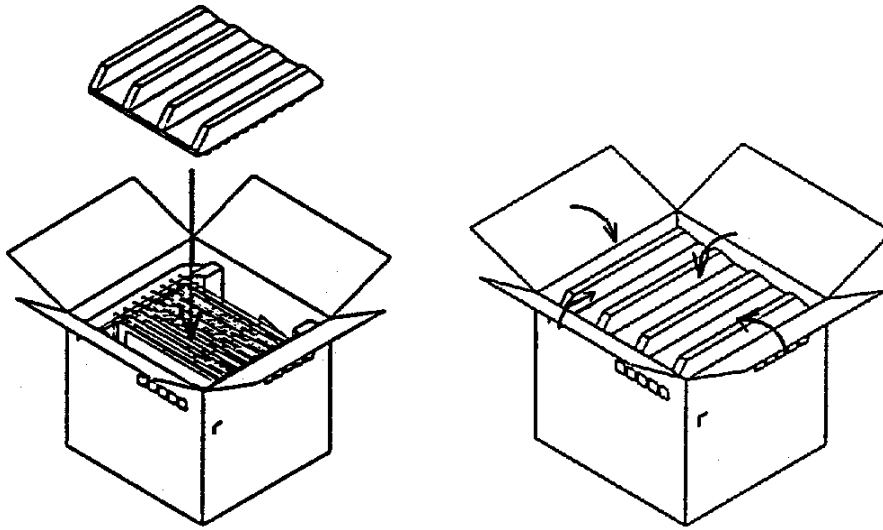

Fig. 9

4. Cautions of shipping & storage

- Do not turn the packaging upside down while storage and transportation. The boxes should not be piled up more than 5.
- Handle with care. Keep off from rain & dew.
- Keep off from direct sunlight exposure. Please store under room temperature & low humidity in original packaging condition when they were shipped.
- Keep other cautions described in handling manual.

Products Number Labeling Forms

Products number label is constructed as below;

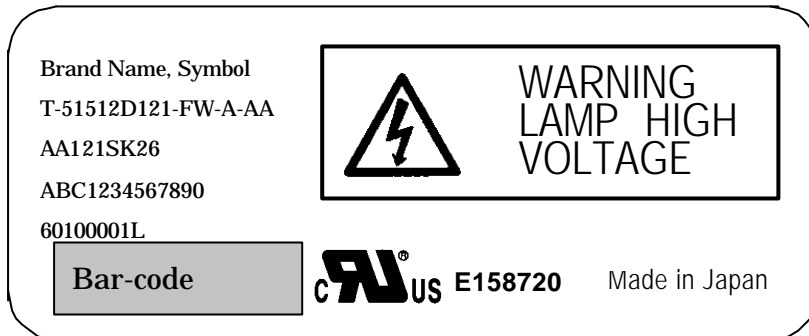

Brand Name, Symbol
 Products Name of Optrex
 Products Name
 Production Key Number(13Digits)
 Date Code
 (Serial Number, Factory Sign)
 Bar-code of Date Code
 UL File No.
 Production Country

Brand Name, Symbol
 OPTREX

Products Name of Optrex
 ex. T51512D121-FW-A-AA

Products Name
 ex.1: AA121SK26 ex.2: AA150XA03 B

Production Key Number(13Digits)
 (ID Number for Production Control)

Date Code (Serial Number, Factory Sign)

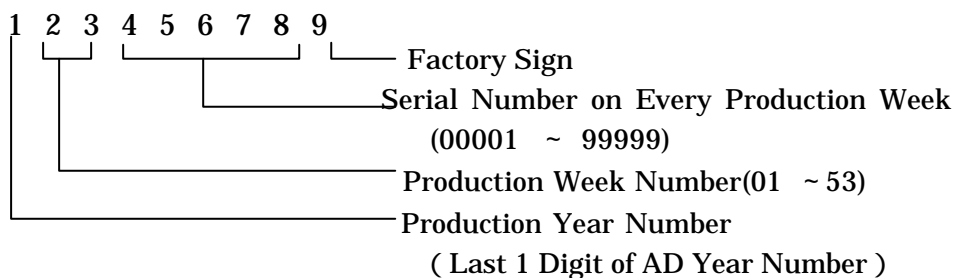

- Date Code is constructed by 9 Digits as below;
 - 1st Digit : Production Year Number (Last 1 Figure of AD Year)
 - 2nd ~ 3rd Digit : Production Week Number in a Year
 (A Year is divided to 53 weeks from Monday to Saturday)
 - 4th ~ 8th Digit : Serial Number on Every Production Weeks.
 (00001 ~ 99999)
 These are numbered in order according to Production Name.
 - 9th Digit : Factory Sign (on the Module Test Process)
 (L: Shisui Factory Line, Y: YACHIYO SANYO Industries Line,
 W: CPT Fab-1, R: CPT Fab-2 , U: CPT Wujiang-LCM)

Bar-code(Date Code)

Bar-code Line for computer reading Date Code mentioned as above.

UL File No.

ADI: E158720, CPT: E194548

Production Country

ADI: Made in Japan, CPT: Made in Taiwan

LAMP UNIT for 12.1"SVGA

APPLICATION

This technical literature applies to the replaceable lamp unit that is the maintenance parts for 12.1" SVGA TFT-LCD module industrial use(model name: T-51512D121J-FW-A-AB).

MECHANICAL CHARACTERISTICS

Item	Specification	Remarks
Outline Dimension of Reflector	266.1±0.2 × 9.15±0.1 × 7.6±0.1 (mm)	Except Wire and Lamp Rubber Cushion
Mass	23(g) (MAX)	
Lamp Diameter	φ2.4-1.8 (mm)	

See DRAWING OF OUTLINE DIMENTIONS

ENVIRONMENTAL CONDITIONS

Item	Operation		Non Operation		Remarks
	MIN	MAX	MIN	MAX	
Ambient Temperature	0°C	60°C	-20°C	70°C	No Condensation

Top, Tstg ≤ 40°C : 90%RH max. without condensation

Top, Tstg > 40°C : Absolute humidity shall be less than the value of 90%RH at 40°C.

ELECTRICAL CHARACTERISTICS

Operation conditions

Item	Symbol	Condition	MIN	TYP	MAX	Unit	Remarks
Lamp Current	IL	Ta=25°C	6.0	12.0	13.0	mArms	
Lamp Voltage	VL	Ta=25°C IL=12.0 mArms	-	540	-	Vrms	
Starting Lamp Voltage	VS	Ta=25°C	1000	-	-	Vrms	
		Ta=0°C	1200	-	-	Vrms	
Lamp Frequency	FL	Ta=25°C IL=12.0 mArms	30	-	60	kHz	

*1) These values are shown by Elevam using E-12324C inverter.

*2) Lamp Current measurement method (The current meter is inserted in low voltage line.)

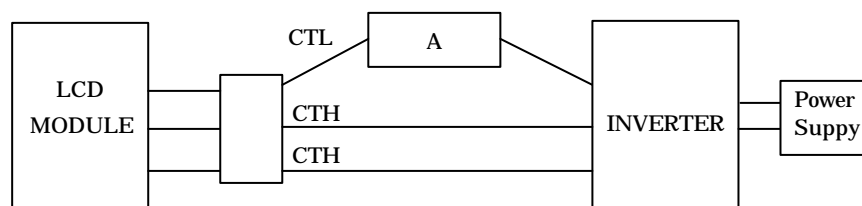

OPTICAL CHARACTERISTICS

Ta=25 ± 2 , 60 ± 10%RH

Item	Symbol	MIN	TYP	MAX	Unit	Remarks
Luminance	Lw	250	350	-	cd/m ²	Average of below 5 points
Color Coordinates (White)	Wx	0.302	0.332	0.362	-	Value of center point(5)
	Wy	0.337	0.367	0.397	-	Value of center point(5)

[Conditions]

IL = 12.0 mArms, Inverter frequency: 55 kHz

[Measurement Point]

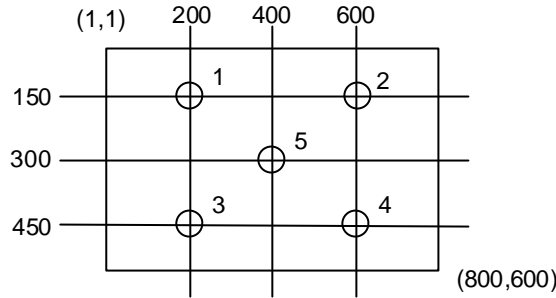

These items are measured when lamp units are assembled into AA121SL**, and using CS1000(MINOLTA) for color coordinates, and CS1000 or BM-5A(TOPCON) for others under the dark room condition (no ambient light) after more than 30 minutes from turning on the lamp unless noted.

LIFE TIME OF THE LAMP UNIT

Environmental Conditions are as follows:

Ambient temperature is 25±2°C.

Lamp Current is 12.0 mArms.

Continuous Operation	50,000 h
Number of turning on and off	100,000 times (30 sec ON-OFF)

- (1) Lamp life time is defined as the time either when the brightness becomes 50% of the initial value, or when the starting lamp voltage does not meet the value specified in the table of section 4.
- (2) The life time of the backlight depends on the ambient temperature. The life time will decrease under low/high temperature.

INTERFACE PIN CONNECTION

Backlight-side connector: BHR-04VS-1 (JST)

Inverter-side connector: SM04(4.0)B-BHS-1(JST)

Pin No.	Symbol	Function
1, 2	CTH	VBLH (High voltage)
4	CTL	VBLL (Low voltage)

[Note]

VBLH - VBLL = VL

DRAWING OF OUTLINE DIMINTIONS



METHOD OF REPLACING THE LAMP UNIT

(1) Precautions

Please pay attention to the following items while replacing the Lamp Unit.

- a. Please do not damage the LCD Panel Surface, and do not touch it with bare hands.
(Wearing gloves is recommended.)
- b. Please be careful with electrostatics, and work in clean environment to prevent entering dust and/or foreign matters that will cause bad display image.
(Using clean bench or similar environment is recommended.)
- c. Please be careful of the edge of the frame metal.

(2) Method of replacing the Lamp Unit

- 1) Put the TFT-LCD Module on the table.(LCD Panel Surface is upside.)

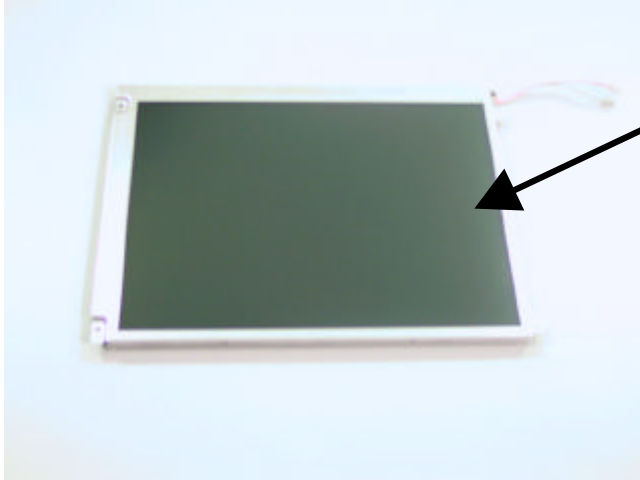

Please check the LCD Panel Surface for scratch, dust, and foreign matters.

Picture 1

- 2) Turn the TFT-LCD Module upside down.

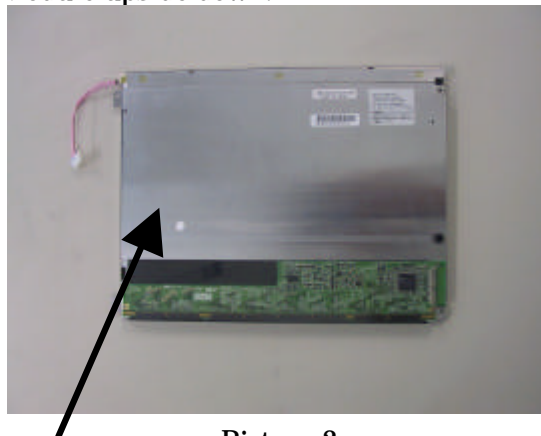

Please check the cable for dust and foreign matters.

Picture 2

- 3) Stand the TFT-LCD Module up and push out the black latch that fastens the Lamp Unit.

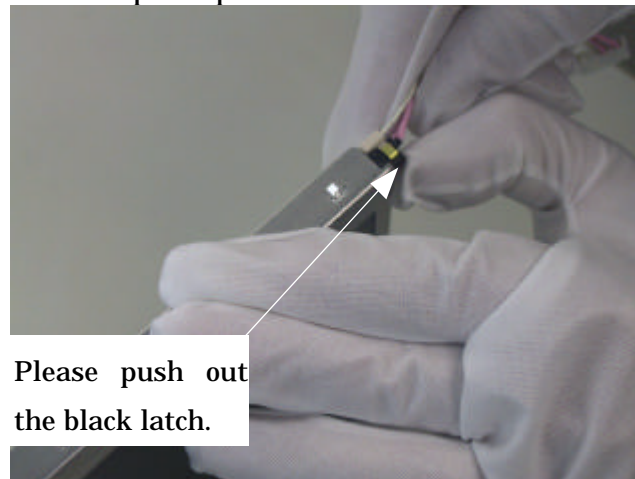

Picture 3

- 4) Pull the cable slowly and remove the Lamp Unit.

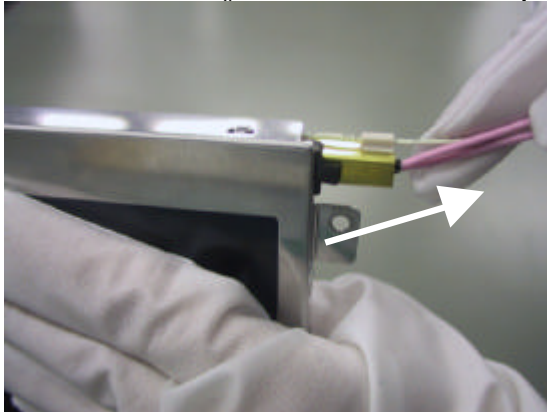

Picture 4

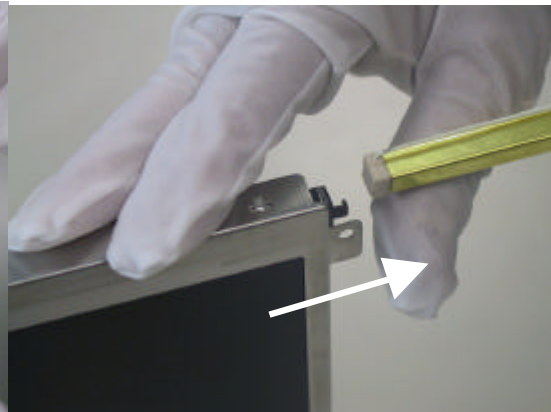

Picture 5

- 5) Picture6 shows the TFT-LCD Module after removing the Lamp Unit.



Picture 6

- 6) Prepare to insert the new Lamp Unit.
- Open the package and take the new Lamp Unit out.
 - Check the new Lamp Unit for dust and foreign matters.

7) Stand the TFT-LCD Module up and insert the new Lamp Unit.

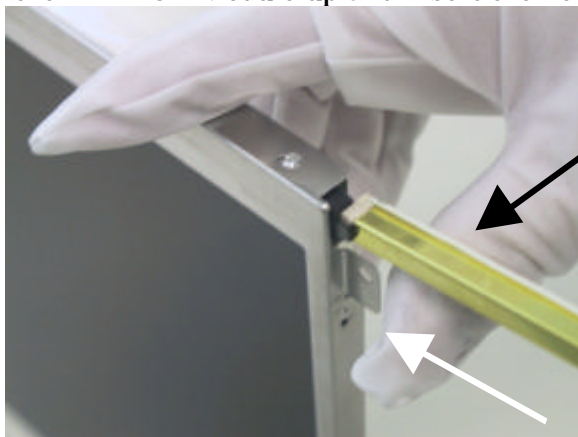

Push out the black latch and insert the new Lamp Unit. (White wire is facing up.)

Picture 7

Please do not insert it in the wrong position.

8) After inserting, please check the Lamp Unit is fastened by the black latch.

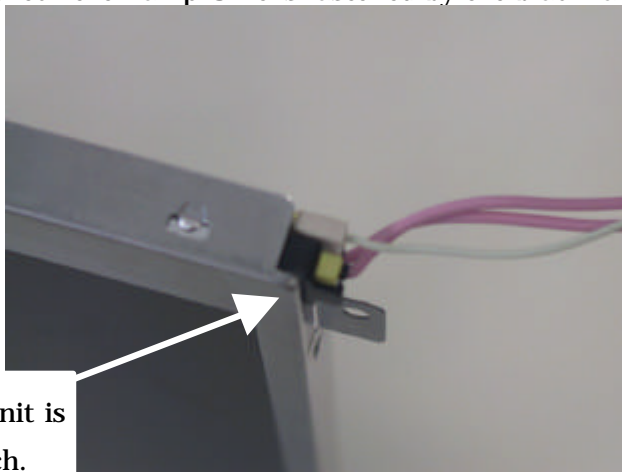

Please check the Lamp Unit is fastened by the black latch.

Picture 8

9) After replacing the Lamp Unit, please check the following items.

- Appearance of TFT-LCD Module is not changed after replacing Lamp Unit. (See Picture 1 and Picture 2)
- There is no damage, dust, or foreign matters on the LCD Panel Surface.
- Install the TFT-LCD Module then check turning on the lamps.