

**SHARP**

No.	<b>LD - 12Y56A</b>
DATE	Dec. 4. 2000

TECHNICAL LITERATURE  
FOR  
TFT - LCD module

MODEL No. **LQ181E1LW31**

The technical literature is subject to change without notice.  
So, please contact Sharp or its representative before designing  
your product based on this literature.

DEVELOPMENT ENGINEERING DEPARTMENT 3  
TFT DIVISION 2  
TFT LIQUID CRYSTAL GROUP  
SHARP CORPORATION



## 1. Application

This specification applies to the color 18.1 SXGA TFT-LCD module LQ181E1LW31.

- ◎These specification sheets are the proprietary product of SHARP CORPORATION("SHARP) and include materials protected under copyright of SHARP. Do not reproduce or cause any third party to reproduce them in any form or by any means, electronic or mechanical, for any purpose, in whole or in part, without the express written permission of SHARP.
- ◎The device listed in these specification sheets was designed and manufactured for use in OA equipment.
- ◎In case of using the device for applications such as control and safety equipment for transportation(aircraft, trains, automobiles, etc. ), rescue and security equipment and various safety related equipment which require higher reliability and safety, take into consideration that appropriate measures such as fail-safe functions and redundant system design should be taken.
- ◎Do not use the device for equipment that requires an extreme level of reliability, such as aerospace applications, telecommunication equipment(trunk lines), nuclear power control equipment and medical or other equipment for life support.
- ◎SHARP assumes no responsibility for any damage resulting from the use of the device which does not comply with the instructions and the precautions specified in these specification sheets.
- ◎Contact and consult with a SHARP sales representative for any questions about this device.

## 2. Overview

This module is a color active matrix LCD module incorporating amorphous silicon TFT (Thin Film Transistor). It is composed of a color TFT-LCD panel, driver ICs, control circuit, power supply circuit and a back light unit. Graphics and texts can be displayed on a  $1280 \times 3 \times 1024$  dots panel with about 16 million colors (8 bit) by supplying 48 bit data signals( $8\text{bit} \times 2\text{pixel} \times \text{RGB}$ ), two display enable signals, two dot clock signals, +12V DC supply voltages for TFT-LCD panel driving and supply voltage for back light.

## 3. Mechanical Specifications

Parameter	Specifications	Unit
Display size	46 (Diagonal)	cm
	18.1 (Diagonal)	Inch
Active area	359.0 (H)×287.2 (V)	Mm
Pixel format	1280 (H)×1024 (V)	Pixel
	(1 pixel=R + G + B dots)	
Pixel pitch	0.2805 (H)×0.2805 (V)	Mm
Pixel configuration	R,G,B vertical stripe	
Display mode	Normally Black	
Unit outline dimensions *1	389 (W)×317.2 (H)×27.5(D)	Mm
Mass	MAX 3.5	kg
Surface treatment	Anti-glare and hard-coating 2H	

\*1.Note: excluding back light cables.

The thickness of module (D) doesn't contain the projection.

Outline dimensions are shown in Fig.1.

## 4. Input Terminals

## 4-1. TFT-LCD panel driving

CN1 (Interface signals and +12VDC power supply)

Using connector : FI-SE30P-HF (Japan Aviation Electronics Ind.,Ltd.)

Mating connector : FI-S30S (Japan Aviation Electronics Ind.,Ltd.)

Pin No.	Symbol	Function	Remark
1	Vcc	+ 1 2 V 電源	
2	Vcc	+ 1 2 V 電源	
3	Vcc	+ 1 2 V 電源	
4	GND	GND	
5	GND	GND	
6	GND	GND	
7	NC	NC	
8	NC	NC	
9	GND	GND	
10	RxBIN3+	Positive (+) LVDS differential data input (B port)	
11	RxBIN3-	Negative (-) LVDS differential data input (B port)	
12	RxBCLKIN+	Positive (+) LVDS differential clock input (B port)	
13	RxBCLKIN-	Negative (-) LVDS differential clock input (B port)	
14	RxBIN2+	Positive (+) LVDS differential data input (B port)	
15	RxBIN2-	Negative (-) LVDS differential data input (B port)	
16	RxBIN1+	Positive (+) LVDS differential data input (B port)	
17	RxBIN1-	Negative (-) LVDS differential data input (B port)	
18	RxBIN0+	Positive (+) LVDS differential data input (B port)	
19	RxBIN0-	Negative (-) LVDS differential data input (B port)	
20	RxAIN3+	Positive (+) LVDS differential data input (A port)	
21	RxAIN3-	Negative (-) LVDS differential data input (A port)	
22	RxACLKIN+	Positive (+) LVDS differential clock input (A port)	
23	RxACLKIN-	Negative (-) LVDS differential clock input (A port)	
24	RxAIN2+	Positive (+) LVDS differential data input (A port)	
25	RxAIN2-	Negative (-) LVDS differential data input (A port)	
26	RxAIN1+	Positive (+) LVDS differential data input (A port)	
27	RxAIN1-	Negative (-) LVDS differential data input (A port)	
28	RxAIN0+	Positive (+) LVDS differential data input (A port)	
29	RxAIN0-	Negative (-) LVDS differential data input (A port)	
30	GND	GND	

## Data Mapping (Thine : THC63LVDM83A)

A port Data			B port Data				
Input Signal	Transmitter		Connector	Input Signal	Transmitter		Connector
	Pin	Data			Pin	Data	
RA 2	5 1	TA 0	RxAIN0±	RB 2	5 1	TA 0	RxBIN0±
RA 3	5 2	TA 1		RB 3	5 2	TA 1	
RA 4	5 4	TA 2		RB 4	5 4	TA 2	
RA 5	5 5	TA 3		RB 5	5 5	TA 3	
RA 6	5 6	TA 4		RB 6	5 6	TA 4	
RA 7	3	TA 5		RB 7	3	TA 5	
GA 2	4	TA 6		GB 2	4	TA 6	
GA 3	6	TB 0	RxAIN1±	GB 3	6	TB 0	RxOIN1±
GA 4	7	TB 1		GB 4	7	TB 1	
GA 5	1 1	TB 2		GB 5	1 1	TB 2	
GA 6	1 2	TB 3		GB 6	1 2	TB 3	
GA 7	1 4	TB 4		GB 7	1 4	TB 4	
BA 2	1 5	TB 5		BB 2	1 5	TB 5	
BA 3	1 9	TB 6		BB 3	1 9	TB 6	
BA 4	2 0	TC 0	RxAIN2±	BB 4	2 0	TC 0	RxBIN2±
BA 5	2 2	TC 1		BB 5	2 2	TC 1	
BA 6	2 3	TC 2		BB 6	2 3	TC 2	
BA 7	2 4	TC 3		BB 7	2 4	TC 3	
RSVD(NA)	2 7	TC 4		RSVD(NA)	2 7	TC 4	
RSVD(NA)	2 8	TC 5		RSVD(NA)	2 8	TC 5	
DEA	3 0	TC 6		DEB	3 0	TC 6	
RA 0	5 0	TD 0	RxAIN3±	RB 0	5 0	TD 0	RxBIN3±
RA 1	2	TD 1		RB 1	2	TD 1	
GA 0	8	TD 2		GB 0	8	TD 2	
GA 1	1 0	TD 3		GB 1	1 0	TD 3	
BA 0	1 6	TD 4		BB 0	1 6	TD 4	
BA 1	1 8	TD 5		BB 1	1 8	TD 5	
RSVD(NA)	2 5	TD 6		RSVD(NA)	2 5	TD 6	
DCLK	3 1	CLKIN	RxACLKIN±	DCLK	3 1	CLKIN	RxBCLKIN±

RSVD : Non connect

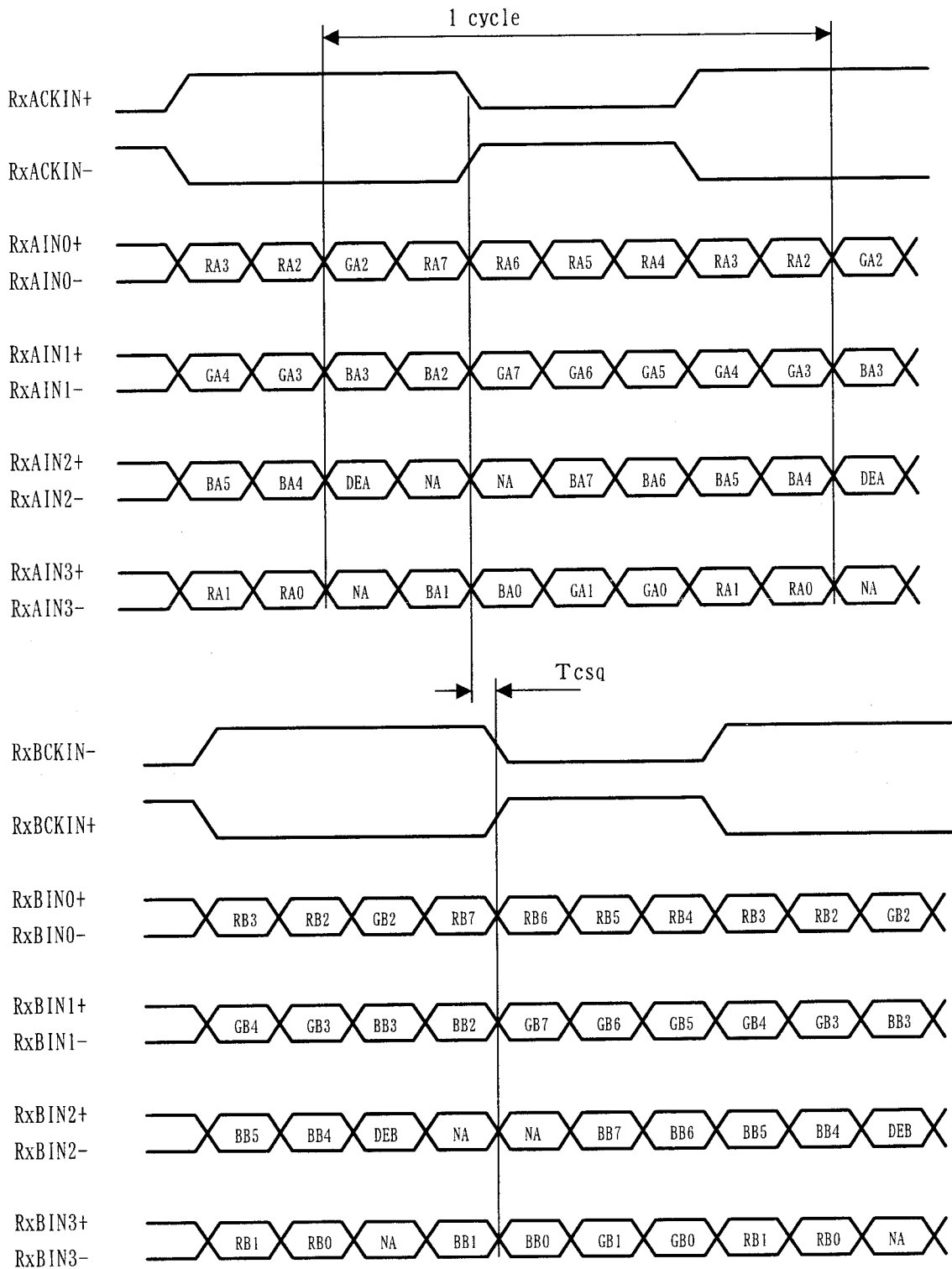

DE: Display Enable  
 NA: Not Available

## 4-2. Back light driving

CN 2, 3

The module-side connector : BHSR-02VS-1 (JST)

The user-side connector : SM02B-BHSS-1-TB (JST)

Pin no.	Symbol	I / O	Function
1	V <sub>HIGH</sub>	I	Power supply for lamp (High voltage side)
2	V <sub>LOW</sub>	I	Power supply for lamp (Low voltage side)

## 5. Absolute Maximum Ratings

## 5-1. Module

Parameter	Symbol	Condition	Ratings	Unit	Remark
Storage temperature	Tstg	—	-25 ~ +60	°C	【Note1】
Operating temperature (Ambient)	Topa	—	0 ~ +50	°C	

【Note1】 Humidity : 95%RH Max. ( Ta ≤ 40°C )

Maximum wet-bulb temperature at 39°C or less. ( Ta &gt; 40°C )

No condensation.

## 5-2. TFT-LCD panel driving

Parameter	Symbol	Condition	Ratings	Unit	Remark
+12.0V supply voltage	Vcc	Ta=25°C	0 ~ + 14.0	V	

6. Electrical Characteristics

6-1. TFT-LCD panel driving

Ta=25°C

Parameter		Symbol	Min.	Typ.	Max.	Unit	Remark
Vcc	Supply voltage	Vcc	+11.4	+12.0	+12.6	V	【Note1】
	Current dissipation	Icc	—	500	1000	mA	【Note2】
Permissible input ripple voltage		V <sub>RF</sub>	—	—	100	mVp-p	
Input current (Low)		I <sub>IL</sub>	—	—	10	μA	V <sub>I</sub> =GND
Input current (High)		I <sub>IH</sub>	—	—	10	μA	V <sub>I</sub> =Vcc
Output voltage (Low)		V <sub>OL</sub>	—	—	0.4	V	I <sub>OL</sub> =1mA
Output voltage (High)		V <sub>OH</sub>	2.4	—	—	V	I <sub>OH</sub> =-1mA

【Note1】

1) On-off sequences of Vcc and data

- 0 < t1 ≤ 60ms
- 0 < t2 ≤ 10ms
- 0 ≤ t3 ≤ 1s
- t4 ≥ 100ms

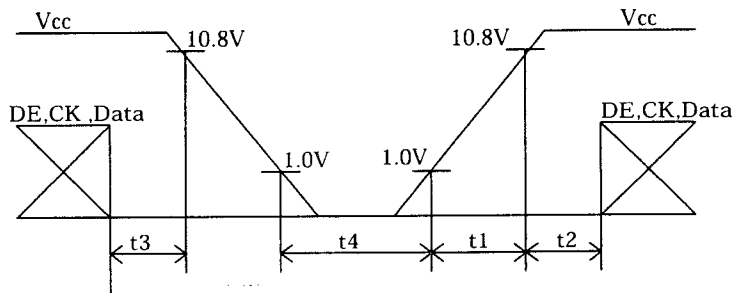

2) Dip conditions for supply voltage

(Vmin, Vth) = (11.4V, 9.6V)

- i) Vth ≤ Vcc < Vmin  
td ≤ 20ms
- ii) Vcc < Vth

This case is described below \*1.

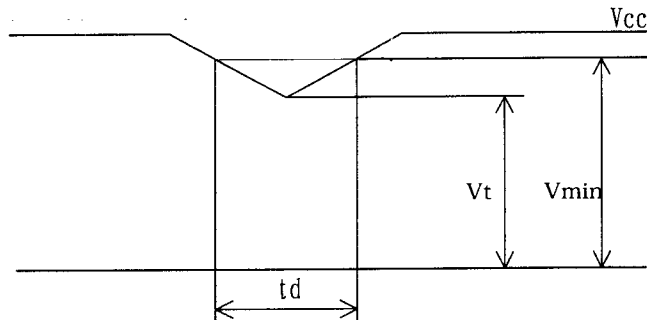

\*1 The LCD module shuts down when Vcc < Vth. It should also follow the 1) on-off sequence of Vcc and data.

【Note2】

1) Typical current situation : 16-gray-bar pattern



Vcc=+12.0V

Gray scale : GS(16N)

N=0~15

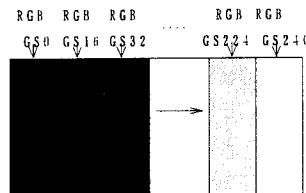

The explanation of each gray scale ,GS(16n), is described below section 8.

## 2) Maximum current situation :

The dots described the following figure(left) are displayed the gray scale described the following figure(right).

R, G, B, R, G, B
R, G, B, R, G, B
R, G, B, R, G, B
R, G, B, R, G, B
R, G, B, R, G, B

0, S, 0, S, 0, S
0, S, 0, S, 0, S
S, 0, S, 0, S, 0
S, 0, S, 0, S, 0
0, S, 0, S, 0, S

\*1 0=V0 gray scale  
S=V255 gray scale

\*1 The voltage correspond one  
of the 256 gray scale.

## 6-2. Back light driving

The back light system is an edge-lighting type with four CCFTs (Cold Cathode Fluorescent Tube). The characteristics of the lamp are shown in the following table. The value mentioned below is at the case of one CCFT.

Parameter	Symbol	Min.	Typ.	Max.	Unit	Remark
Lamp current range	$I_L$	2.5	6.0	7.0	mArms	【Note1】
Lamp voltage	$V_L$	—	720	—	Vrms	$T_a=25^\circ\text{C}$
Lamp power consumption	$P_L$	—	4.32	—	W	【Note2】
Lamp frequency	$F_L$	35	60	70	KHz	【Note3】
Kick-off voltage	$V_s$	—	—	1300	Vrms	$T_a=25^\circ\text{C}$ 【Note4】
		—	—	1600	Vrms	$T_a=0^\circ\text{C}$ 【Note4】
Lamp life time	$T_L$	50000	—	—	hour	【Note5】

【Note1】 A lamp can be light in the range of lamp current shown above.

Maximum rating for current is measured by high frequency current measurement equipment connected to  $V_{\text{LOW}}$  at circuit showed below. (Note : To keep enough kick-off voltage and necessary steady voltage for CCFT.)

Lamp frequency : 35~70kHz

Ambient temperature : 0~50°C

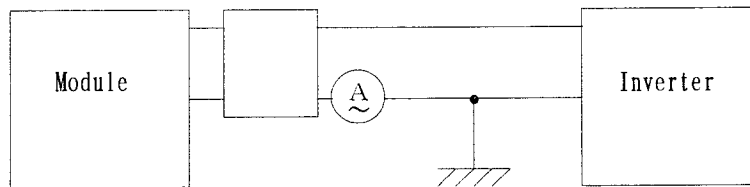

【Note2】 Referential data per one CCFT by calculation ( $I_L \times V_L$ ).

The data don't include loss at inverter.

【Note3】 Lamp frequency may produce interference with horizontal synchronous frequency, and this may cause beat on the display. Therefore lamp frequency shall be detached as much as possible from the horizontal synchronous frequency and from the harmonics of horizontal synchronous to avoid interference.

【Note4】 The voltage above this value should be applied to the lamp for more than 1 second to startup. Otherwise the lamp may not be turned on.

【Note5】 Lamp life time is defined as the time when either ① or ② occurs in the continuous operation under the condition of  $T_a=25^\circ\text{C}$  and  $I_L=7.0$  mArms.

① Brightness becomes 50% of the original value under standard condition.

② Kick-off voltage at  $T_a=0^\circ\text{C}$  exceeds maximum value, 1600 Vrms.

《Note》 The performance of the back light, for example life time or brightness, is much influenced by the characteristics of the DC-AC inverter for the lamp. When you design or order the inverter, please make sure that a poor lighting caused by the mismatch of the back light and the inverter (miss-lighting, flicker, etc.) never occurs. When you confirm it, the module should be operated in the same condition as it is installed in your instrument.

## 7. Timing characteristics of input signals

## 7-1. 2pixel mode timing characteristics

Timing diagrams of input signal are shown in Fig.2.

Parameter		Symbol	Min.	Typ.	Max.	Unit	Remark
Clock	Frequency	1/Tc	34	55	67.5	MHz	[Note1]
	Skew	Tcsq	-1	0	1	clock	
Data enable signal	Horizontal period	TH	800	848	928	clock	
			12.5	15	—	μs	
	Horizontal period (High)	THd	640	640	640	clock	
	Vertical period	TV	1026	1066	1080	line	[Note2]
Vertical period (High)	TVd	1024	1024	1024	line		

【Note1】 Two pixel-data are sampled at the same time.

【Note2】 In case of using the long vertical period, the deterioration of display quality, flicker etc. may occur.

There should be integral horizontal period per one vertical period.

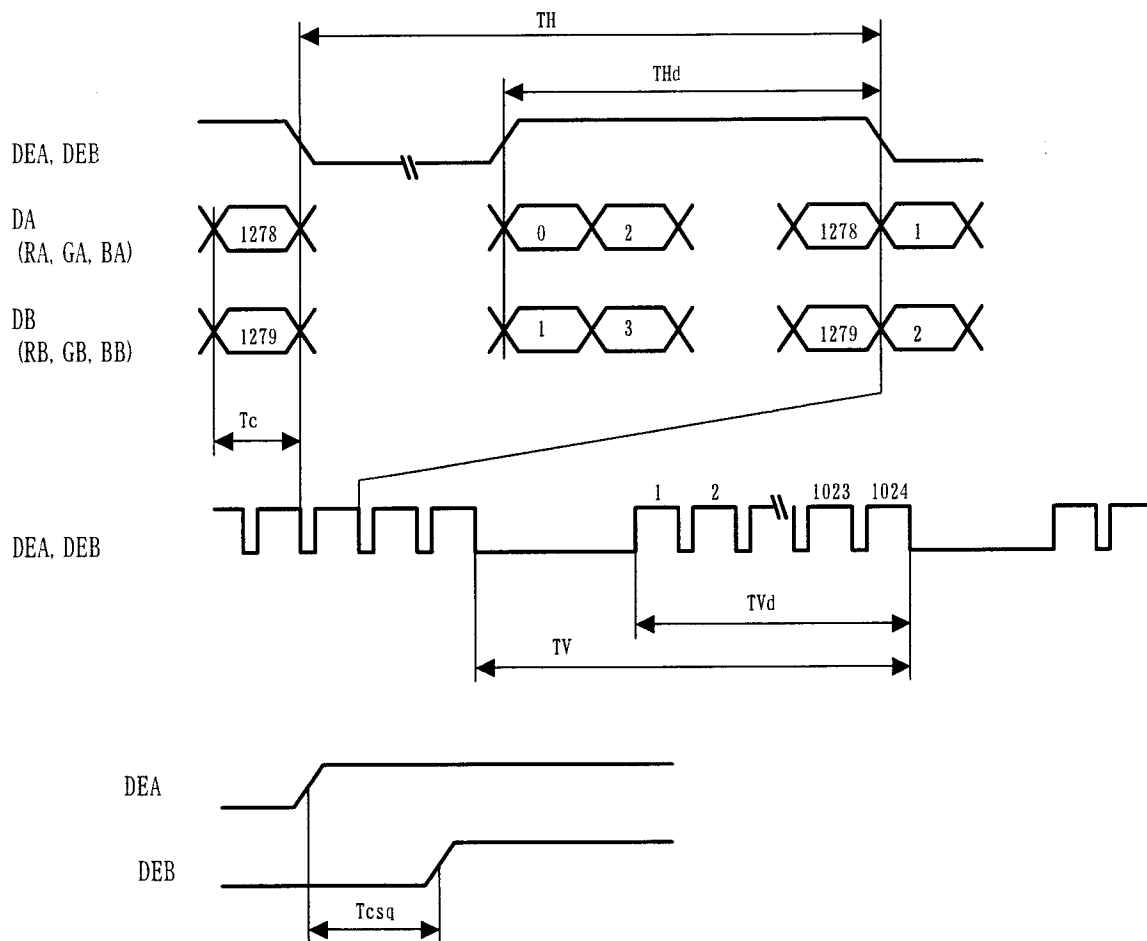
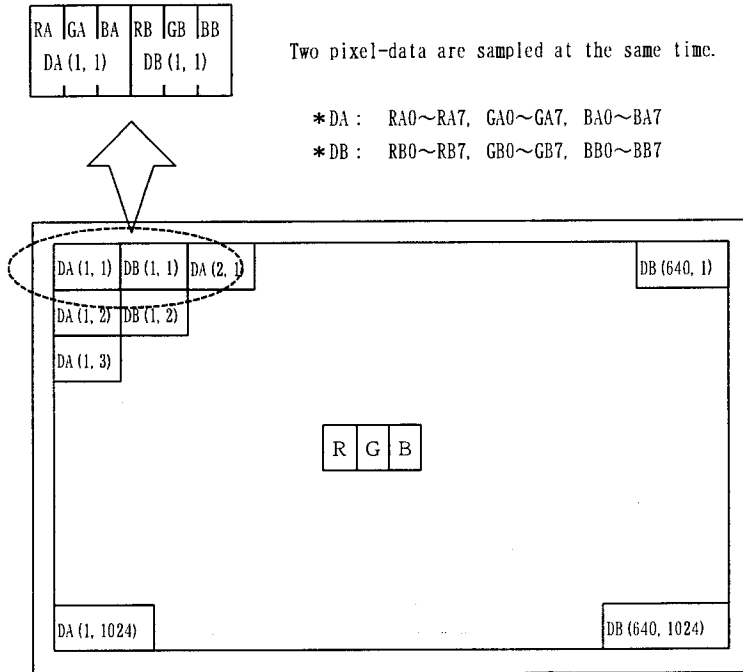

Fig. 2 Timing diagrams of input signal

## 7-2 Input Data Signals and Display Position on the screen

Graphics and texts can be displayed on a  $1280 \times 3 \times 1024$  dots panel with 16M colors by supplying 48 bit data signal (8bit/color [256 gray scale]  $\times 3 \times 2$  pixels).



Display position of input data (H, V)

8. Input Signals, Basic Display Colors and Gray Scale of Each Color

Colors & Gray scale	Data signal																											
	Gray Scale	RA0 RA1 RA2 RA3 RA4 RA5 RA6 RA7								GA0 GA1 GA2 GA3 GA4 GA5 GA6 GA7								BA0 BA1 BA2 BA3 BA4 BA5 BA6 BA7										
		RB0 RB1 RB2 RB3 RB4 RB5 RB6 RB7								GB0 GB1 GB2 GB3 GB4 GB5 GB6 GB7								BB0 BB1 BB2 BB3 BB4 BB5 BB6 BB7										
		RC0 RC1 RC2 RC3 RC4 RC5 RC6 RC7								GC0 GC1 GC2 GC3 GC4 GC5 GC6 GC7								BC0 BC1 BC2 BC3 BC4 BC5 BC6 BC7										
RD0 RD1 RD2 RD3 RD4 RD5 RD6 RD7								GD0 GD1 GD2 GD3 GD4 GD5 GD6 GD7								BD0 BD1 BD2 BD3 BD4 BD5 BD6 BD7												
Basic Color	Black	—	0	0	0	0	0	0	0	0	0	0	0	0	0	0	0	0	0	0	0	0	0	0	0	0	0	0
	Blue	—	0	0	0	0	0	0	0	0	0	0	0	0	0	0	0	0	0	0	0	0	0	0	0	0	0	0
	Green	—	0	0	0	0	0	0	0	0	0	0	0	0	0	0	0	0	0	0	0	0	0	0	0	0	0	0
	Cyan	—	0	0	0	0	0	0	0	0	0	0	0	0	0	0	0	0	0	0	0	0	0	0	0	0	0	0
	Red	—	1	1	1	1	1	1	1	1	1	1	1	1	1	1	1	1	1	1	1	1	1	1	1	1	1	1
	Magenta	—	1	1	1	1	1	1	1	1	1	1	1	1	1	1	1	1	1	1	1	1	1	1	1	1	1	1
	Yellow	—	1	1	1	1	1	1	1	1	1	1	1	1	1	1	1	1	1	1	1	1	1	1	1	1	1	1
	White	—	1	1	1	1	1	1	1	1	1	1	1	1	1	1	1	1	1	1	1	1	1	1	1	1	1	1
Gray Scale of Red	Black	GS0	0	0	0	0	0	0	0	0	0	0	0	0	0	0	0	0	0	0	0	0	0	0	0	0	0	0
	↑	GS1	1	0	0	0	0	0	0	0	0	0	0	0	0	0	0	0	0	0	0	0	0	0	0	0	0	0
	Darker	GS2	0	1	0	0	0	0	0	0	0	0	0	0	0	0	0	0	0	0	0	0	0	0	0	0	0	0
	↑	↓																										
	↓	↓																										
	Brighter	GS250	1	0	1	1	1	1	1	1	1	1	1	1	1	1	1	1	1	1	1	1	1	1	1	1	1	1
	↓	GS251	0	1	1	1	1	1	1	1	1	1	1	1	1	1	1	1	1	1	1	1	1	1	1	1	1	1
	Red	GS252	1	1	1	1	1	1	1	1	1	1	1	1	1	1	1	1	1	1	1	1	1	1	1	1	1	1
Gray Scale of Green	Black	GS0	0	0	0	0	0	0	0	0	0	0	0	0	0	0	0	0	0	0	0	0	0	0	0	0	0	0
	↑	GS1	0	0	0	0	0	0	0	0	0	0	0	0	0	0	0	0	0	0	0	0	0	0	0	0	0	0
	Darker	GS2	0	0	0	0	0	0	0	0	0	0	0	0	0	0	0	0	0	0	0	0	0	0	0	0	0	0
	↑	↓																										
	↓	↓																										
	Brighter	GS250	0	0	0	0	0	0	0	0	0	0	0	0	0	0	0	0	0	0	0	0	0	0	0	0	0	0
	↓	GS251	0	0	0	0	0	0	0	0	0	0	0	0	0	0	0	0	0	0	0	0	0	0	0	0	0	0
	Green	GS252	0	0	0	0	0	0	0	0	0	0	0	0	0	0	0	0	0	0	0	0	0	0	0	0	0	0
Gray Scale of Blue	Black	GS0	0	0	0	0	0	0	0	0	0	0	0	0	0	0	0	0	0	0	0	0	0	0	0	0	0	0
	↑	GS1	0	0	0	0	0	0	0	0	0	0	0	0	0	0	0	0	0	0	0	0	0	0	0	0	0	0
	Darker	GS2	0	0	0	0	0	0	0	0	0	0	0	0	0	0	0	0	0	0	0	0	0	0	0	0	0	0
	↑	↓																										
	↓	↓																										
	Brighter	GS250	0	0	0	0	0	0	0	0	0	0	0	0	0	0	0	0	0	0	0	0	0	0	0	0	0	0
	↓	GS251	0	0	0	0	0	0	0	0	0	0	0	0	0	0	0	0	0	0	0	0	0	0	0	0	0	0
	Blue	GS252	0	0	0	0	0	0	0	0	0	0	0	0	0	0	0	0	0	0	0	0	0	0	0	0	0	0

0 : Low level voltage, 1 : High level voltage.

Each basic color can be displayed in 256 gray scales from 8 bit data signals. According to the combination of total 48 bit data signals, the 16-million-color display can be achieved on the screen.

## 9. Optical Characteristics

Ta=25°C, Vcc=+12V

Parameter		Symbol	Condition	Min.	Typ.	Max.	Unit	Remark
Viewing Angle range	Vertical	$\theta 11$	$CR \geq 10$	70	85	—	Deg.	【Note1,4】
		$\theta 12$		70	85	—	Deg.	
	Horizontal	$\theta 21, \theta 22$		70	85	—	Deg.	
Contrast ratio		C R	$\theta = 0^\circ$	—	350	—		【Note2,4】
Response Time	Rise	$\tau r$		—	5	—	m s	【Note3,4】
	Decay	$\tau d$		—	20	—	m s	
Chromaticity of white		Wx		0.283	0.313	0.343	—	【Note4】
		Wy		0.299	0.329	0.359	—	
Chromaticity of red		Rx		0.60	0.63	0.66	—	
		Ry		0.31	0.34	0.37	—	
Chromaticity of green		Gx		0.24	0.27	0.30	—	
		Gy		0.56	0.59	0.62	—	
Chromaticity of blue		Bx		0.12	0.15	0.18	—	
		By	0.05	0.08	0.11	—		
Luminance of white		YL	—	235	—	cd/m <sup>2</sup>	IL=6.0mA rms 【Note4】	
White Uniformity		$\delta w$	—	—	1.25	—	【Note5】	

※The measurement shall be executed 30 minutes after lighting at rating.

The optical characteristics shall be measured in a dark room or equivalent state with the method shown in Fig.4 below.

【Note1】 Definitions of viewing angle range:

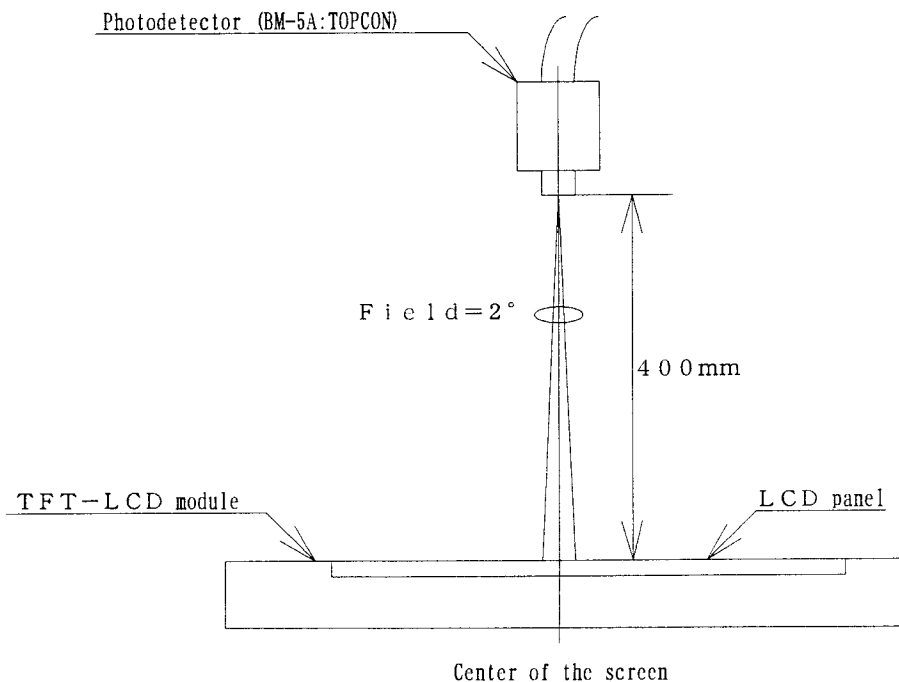
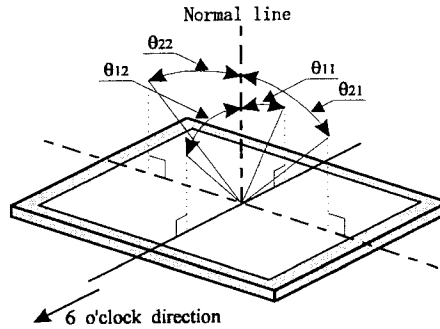

Fig.4 Optical characteristics measurement method



【Note2】 Definition of contrast ratio:

The contrast ratio is defined as the following.

$$\text{Contrast Ratio (CR)} = \frac{\text{Luminance (brightness) with all pixels white}}{\text{Luminance (brightness) with all pixels black}}$$

【Note3】 Definition of response time:

The response time is defined as the following figure and shall be measured by switching the input signal for "black" and "white".

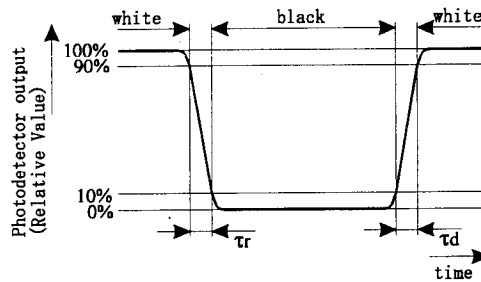

【Note4】 This shall be measured at center of the screen.

【Note5】 Definition of white uniformity:

White uniformity is defined as the following with five measurements (A~E).

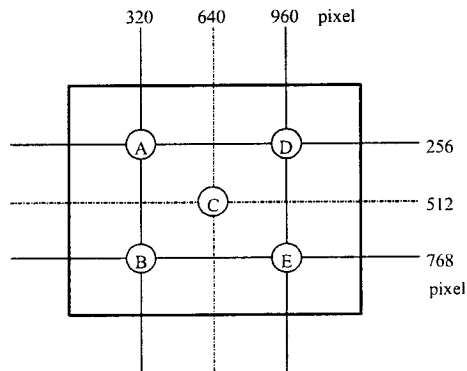

$$\delta w = \frac{\text{Maximum Luminance of five points (brightness)}}{\text{Minimum Luminance of five points (brightness)}}$$

#### 10. Handling Precautions

- a) Be sure to turn off the power supply when inserting or disconnecting the cable.
- b) Be sure to design the cabinet so that the module can be installed without any extra stress such as warp or twist.
- c) Since the front polarize is easily damaged, pay attention not to scratch it.
- d) Since long contact with water may cause discoloration or spots, wipe off water drop immediately.
- e) When the panel surface is soiled, wipe it with absorbent cotton or other soft cloth.
- f) Since the panel is made of glass, it may break or crack if dropped or bumped on hard surface. Handle with care.
- g) Since CMOS LSI is used in this module, take care of static electricity and take the human earth into consideration when handling.
- h) Make sure the four mounting holes of the module are grounded sufficiently. Take electro-magnetic interference (EMI) into consideration.
- i) The module has some printed circuit boards (PCBs) on the back side. Take care to keep them from any stress or pressure when handling or installing the module; otherwise some of electronic parts on the PCBs may be damaged.
- j) Observe all other precautionary requirements in handling components.
- k) When some pressure is added onto the module from rear side constantly, it causes display non-uniformity issue, functional defect, etc. So, please avoid such design.
- l) When giving a touch to the panel at power supply, it may cause some kinds of degradation. In that case, once turn off the power supply, and turn on after several seconds again, and that is disappear.

#### 11. Packing form

- a) Piling number of cartons : maximum 12 cartons
- b) Packing quantity in one carton : 1 module
- c) Carton size : TBD(W) × TBD(H) × TBD(D)
- d) Total mass of one carton filled with full modules : 5kg

## 12. Reliability test items

No.	Test item	Conditions
1	High temperature storage test	Ta=60°C 240h
2	Low temperature storage test	Ta=-25°C 240h
3	High temperature & high humidity operation test	Ta=40°C ; 95%RH 240h (No condensation)
4	High temperature operation test	Ta=50°C 240h (The panel temp. must be less than 60°C)
5	Low temperature operation test	Ta=0°C 240H
6	Vibration test (non- operating)	Frequency : 10~57Hz/Vibration width (one side) : 0.075mm : 58~500Hz/Gravity : 9.8m/s <sup>2</sup> Sweep time : 11minutes Test period : 3 hours (1 hour for each direction of X,Y,Z)
7	Shock test (non- operating)	Max. gravity : 490m/s <sup>2</sup> Pulse width : 11ms, sine wave Direction : ±X, ±Y, ±Z, once for each direction.

## 【Result Evaluation Criteria】

Under the display quality test conditions with normal operation state, these shall be no change which may affect practical display function.

## 13. Others

1) Lot No. and indication Label:

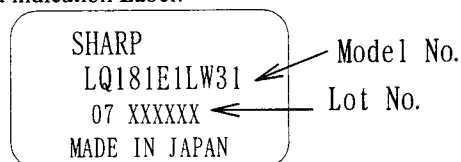

How to express Lot No.

A production year (the last figures of the Christian

A production month (1~9, X, Y, Z)

Serial No.

- 2) Adjusting volume have been set optimally before shipment, so do not change any adjusted value.  
If adjusted value is changed, the specification may not be satisfied.
- 3) Disassembling the module can cause permanent damage and should be strictly avoided.
- 4) Please be careful since image retention may occur when a fixed pattern is displayed for a long time.
- 5) When any question or issue occurs , it shall be solved by mutual discussion.

NOTES  
 1) SPECIFIED TOLERANCE TO BE +0.5  
 2) WARP AND FLATTING FOR PCB AND CHASSIS ARE EXCLUDED FROM THICKNESS AND DIMENSIONS OF THE UNIT

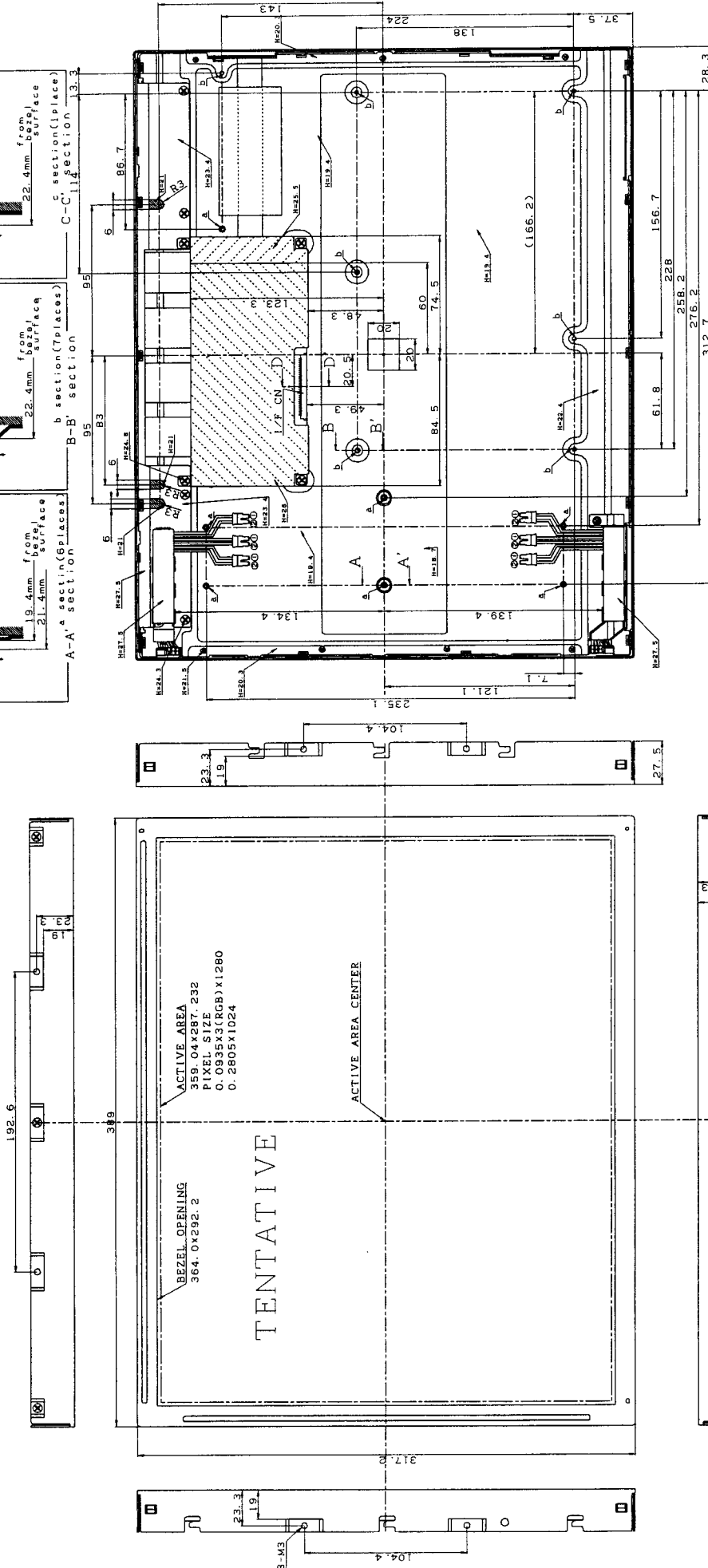

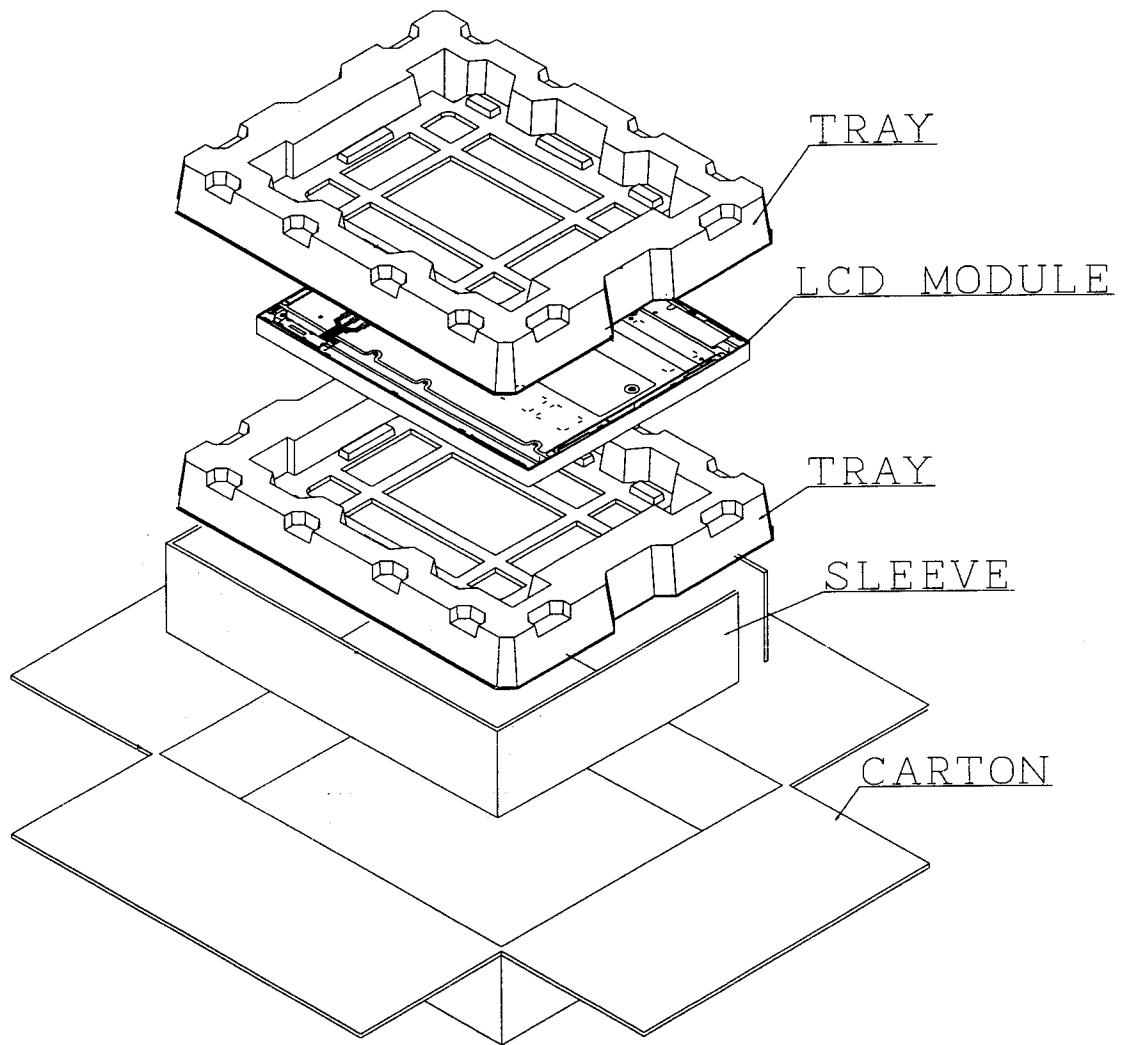

PACKING BAND

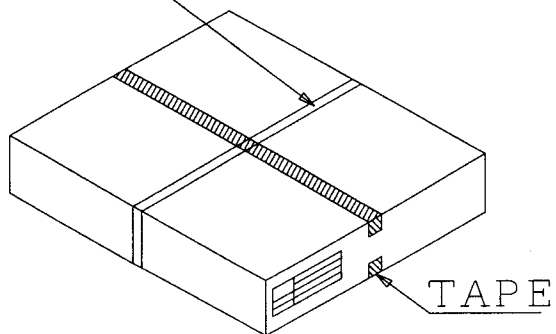

PACKING FORM