



Gleichmann & Co. Electronics GmbH  
 Product Marketing Displays & Systems  
 Schraderstr. 44, D- 67227 Frankenthal  
 Tel : +49 7249-910-0, Fax: +49 7249-910-559  
 display@msc-ge.com http://www.msc-ge.com

Preliminary Specifications  
 Final Specifications

<b>Module</b>	15 Inch Color TFT-LCD
<b>Model Name</b>	G150XG01 V2

<b>Customer</b>	<b>Date</b>
<b>Checked &amp; Approved by</b>	
_____	_____
<p>Note: This Specification is subject to change without notice.</p>	

<b>Approved by</b>	<b>Date</b>
<u>Debbie Chiu</u>	<u>2008/11/19</u>
<b>Prepared by</b>	
<u>Danny Wang</u>	<u>2008/11/19</u>
<p>General Display Business Division /                  AU Optronics corporation</p>	

## Contents

<b>1. Operating Precautions .....</b>	<b>4</b>
<b>2. General Description .....</b>	<b>5</b>
2.1 Display Characteristics .....	5
2.2 Optical Characteristics .....	6
<b>3. Functional Block Diagram .....</b>	<b>9</b>
<b>4. Absolute Maximum Ratings.....</b>	<b>10</b>
4.1 Absolute Ratings of TFT LCD Module.....	10
4.2 Absolute Ratings of Environment.....	10
<b>5. Electrical Characteristics.....</b>	<b>11</b>
5.1 TFT LCD Module .....	11
5.2 Backlight Unit .....	13
<b>6. Signal Characteristic.....</b>	<b>14</b>
6.1 Pixel Format Image.....	14
6.2 Scanning Direction.....	14
6.3 Signal Description .....	15
6.4 The Input Data Format.....	16
6.5 Interface Timing .....	17
6.6 Power ON/OFF Sequence .....	18
<b>7. Connector &amp; Pin Assignment .....</b>	<b>19</b>
7.1 TFT LCD Module: LVDS Connector.....	19
7.2 Backlight Unit: Lamp Connector .....	21
7.3 Lamp Connector Pin Assignment.....	21
<b>8. Reliability Test Criteria.....</b>	<b>22</b>
<b>9. Mechanical Characteristics .....</b>	<b>23</b>
9.1 LCM Front View and Rear View .....	23
9.2 LCM Outline Dimension (Front View).....	24
9.3 LCM Outline Dimension (Rear View) .....	25
<b>10. Label and Packaging.....</b>	<b>26</b>
10.1 Shipping Label (on the rear side of TFT-LCD display) .....	26
10.2 Carton Package .....	26
<b>11 Safety.....</b>	<b>27</b>
11.1 Sharp Edge Requirements.....	27
11.2 Materials.....	27
11.3 Capacitors .....	27
11.4 National Test Lab Requirement.....	27



**Record of Revision**

<b>Version and Date</b>	<b>Page</b>	<b>Old description</b>	<b>New Description</b>
0.0 2008/11/19	All	First Edition	

## 1. Operating Precautions

- 1) Since front polarizer is easily damaged, please be cautious and not to scratch it.
- 2) Be sure to turn off power supply when inserting or disconnecting from input connector.
- 3) Wipe off water drop immediately. Long contact with water may cause discoloration or spots.
- 4) When the panel surface is soiled, wipe it with absorbent cotton or soft cloth.
- 5) Since the panel is made of glass, it may be broken or cracked if dropped or bumped on hard surface.
- 6) Since CMOS LSI is used in this module, take care of static electricity and insure human earth when handling.
- 7) Do not open nor modify the module assembly.
- 8) Do not press the reflector sheet at the back of the module to any direction.
- 9) In case if a module has to be put back into the packing container slot after it was taken out from the container, do not press the center of the CCFL Reflector edge. Instead, press at the far ends of the CFL Reflector edge softly. Otherwise the TFT Module may be damaged.
- 10) At the insertion or removal of the Signal Interface Connector, be sure not to rotate nor tilt the Interface Connector of the TFT Module.
- 11) TFT-LCD Module is not allowed to be twisted & bent even force is added on module in a very short time. Please design your display product well to avoid external force applying to module by end-user directly.
- 12) Small amount of materials without flammability grade are used in the TFT-LCD module. The TFT-LCD module should be supplied by power complied with requirements of Limited Power Source (IEC60950 or UL1950), or be applied exemption.
- 13) Severe temperature condition may result in different luminance, response time.
- 14) Continuous operating TFT-LCD Module under high temperature environment may accelerate LED light bar exhaustion and reduce luminance dramatically.
- 15) The data on this specification sheet is applicable when TFT-LCD module is placed in landscape position.
- 16) Continuous displaying fixed pattern may induce image sticking. It's recommended to use screen saver or moving content periodically if fixed pattern is displayed on the screen.

## 2. General Description

G150XG01 V2 is a Color Active Matrix Liquid Crystal Display composed of a TFT-LCD display, a driver circuit, and a backlight system. The screen format is intended to support XGA (1024(H) x 768(V)) screen and 16.2M (RGB 8-bits) or 262k colors (RGB 6-bits). All input signals are LVDS interface compatible. All design rules of this module can correspond to PSWG standard.

G150XG01 V2 is designed for industrial display applications.

### 2.1 Display Characteristics

The following items are characteristics summary on the table under 25 °C condition:

Items	Unit	Specifications
Screen Diagonal	[inch]	15
Active Area	[mm]	304.128(H) x 228.096(V)
Pixels H x V		1024x3(RGB) x 768
Pixel Pitch	[mm]	0.297 x 0.297
Pixel Arrangement		R.G.B. Vertical Stripe
Display Mode		TN, Normally White
Nominal Input Voltage VDD	[Volt]	3.3 typ.
Typical Power Consumption	[Watt]	(8.8) ( 64 Gray Bar Pattern , exclude inverter)
Weight	[Grams]	1100g (max.)
Physical Size	[mm]	326.5(H)x 253.5(V) x 12.0(D) (max.)
Electrical Interface		1 channel LVDS
Surface Treatment		Anti-glare, Hardness 3H
Support Color		16.2M / 262K colors
Temperature Range		
Operating	[°C]	0 to +65 (+65 °C as panel surface temperature)
Storage (Non-Operating)	[°C]	-20 to +65
RoHS Compliance		RoHS Compliance

## 2.2 Optical Characteristics

The optical characteristics are measured under stable conditions at 25°C (Room Temperature):

Item	Unit	Conditions	Min.	Typ.	Max.	Note
White Luminance	[cd/m <sup>2</sup> ]	IRCFL= 5.5mA (center point)	300	350	-	1
Uniformity	%	9 Points	75	80	-	1, 2, 3
Contrast Ratio			400	700	-	4
Cross talk	%		-	1.2	1.5	5
Response Time	[msec]	Rising	-	5.7		6
	[msec]	Falling	-	2.3		
	[msec]	Raising + Falling	-	8		
Viewing Angle	[degree]	Horizontal (Right) CR = 10 (Left)	70	80	-	7
	[degree]		70	80	-	
	[degree]	Vertical (Upper) CR = 10 (Lower)	70	80	-	
Color / Chromaticity Coordinates (CIE 1931)		Red x	TBD	(0.642)	TBD	
		Red y	TBD	(0.337)	TBD	
		Green x	TBD	(0.306)	TBD	
		Green y	TBD	(0.581)	TBD	
		Blue x	TBD	(0.144)	TBD	
		Blue y	TBD	(0.101)	TBD	
		White x	TBD	(0.313)	TBD	
		White y	TBD	(0.329)	TBD	
Color Gamut	%			65	-	

Note 1: Measurement method

Equipment Pattern Generator, Power Supply, Digital Voltmeter, Luminance meter (SR\_3 or equivalent)

Aperture 1° with 50cm viewing distance

Test Point Center

Environment < 1 lux

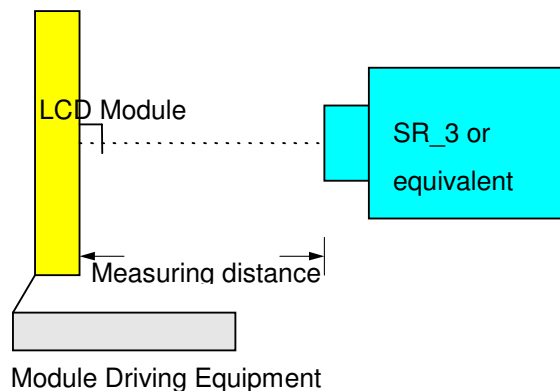

Note 2: Definition of 9 points position (Display active area : 304.128(H) x 228.096(V))

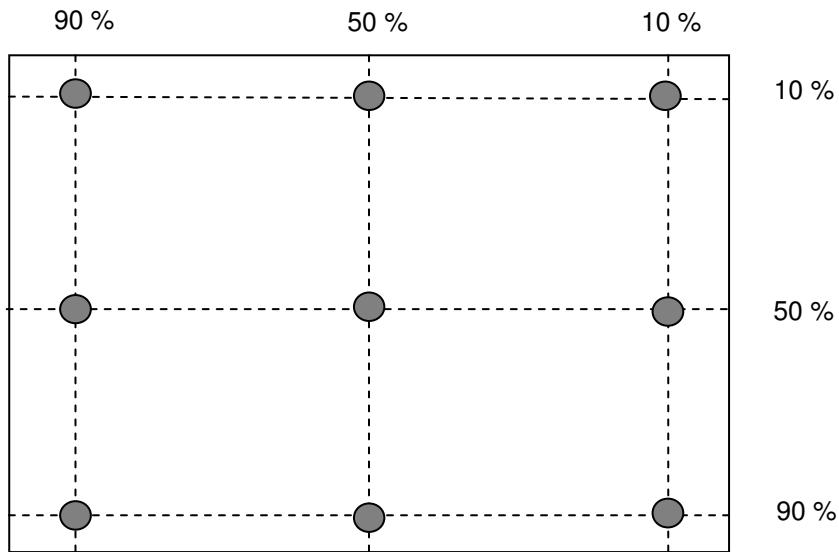

Note 3: The luminance uniformity of 9 points is defined by dividing the minimum luminance values by the maximum test point luminance

$$\delta_{w9} = \frac{\text{Minimum Brightness of nine points}}{\text{Maximum Brightness of nine points}}$$

Note 4 : Definition of contrast ratio (CR):

$$\text{Contrast ratio (CR)} = \frac{\text{Brightness on the "White" state}}{\text{Brightness on the "Black" state}}$$

Note 5 : Definition of cross talk (CT)

$$CT = | YB - YA | / YA \times 100 (\%)$$

Where

YA = Luminance of measured location without gray level 0 pattern (cd/m2)

YB = Luminance of measured location with gray level 0 pattern (cd/m2)

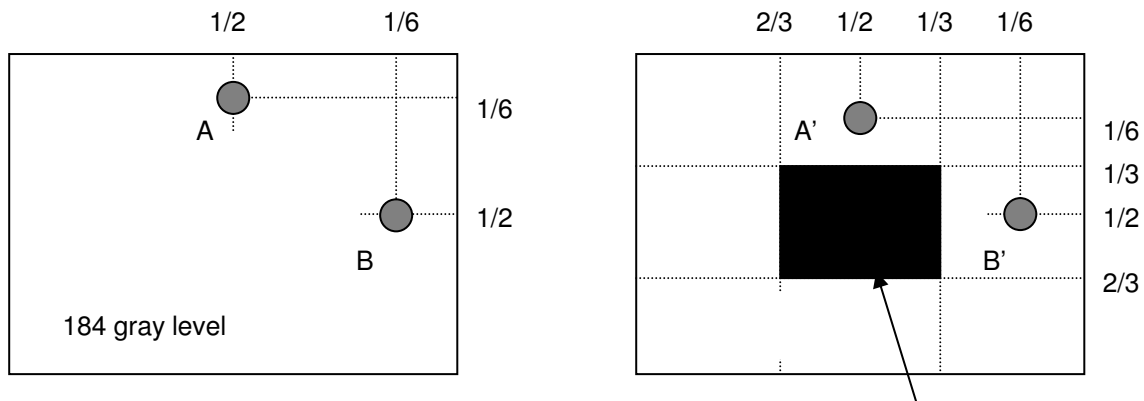

Note 6: Definition of response time:

The output signals of photo detector are measured when the input signals are changed from “White” to “Black” (falling time) and from “Black” to “White” (rising time), respectively. The response time interval is between 10% and 90% of amplitudes. Please refer to the figure as below.

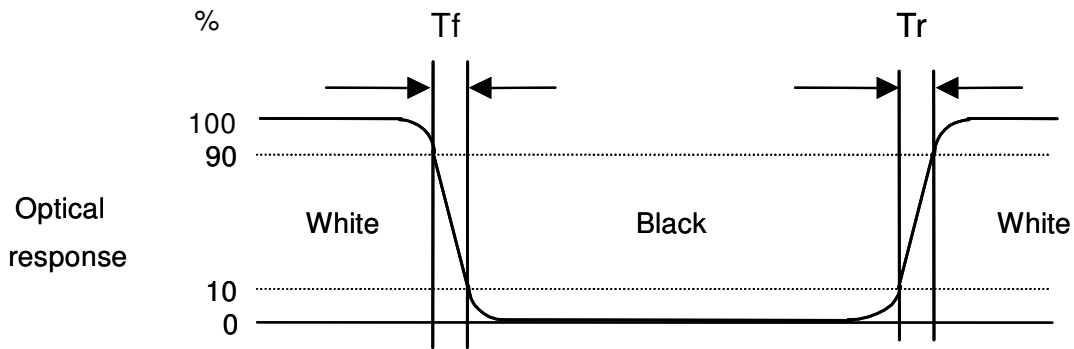

Note 7: Definition of viewing angle

Viewing angle is the measurement of contrast ratio  $\geq 10$ , at the screen center, over a 180° horizontal and 180° vertical range (off-normal viewing angles). The 180° viewing angle range is broken down as below: 90° ( $\theta$ ) horizontal left and right, and 90° ( $\phi$ ) vertical high (up) and low (down). The measurement direction is typically perpendicular to the display surface with the screen rotated to its center to develop the desired measurement viewing angle.

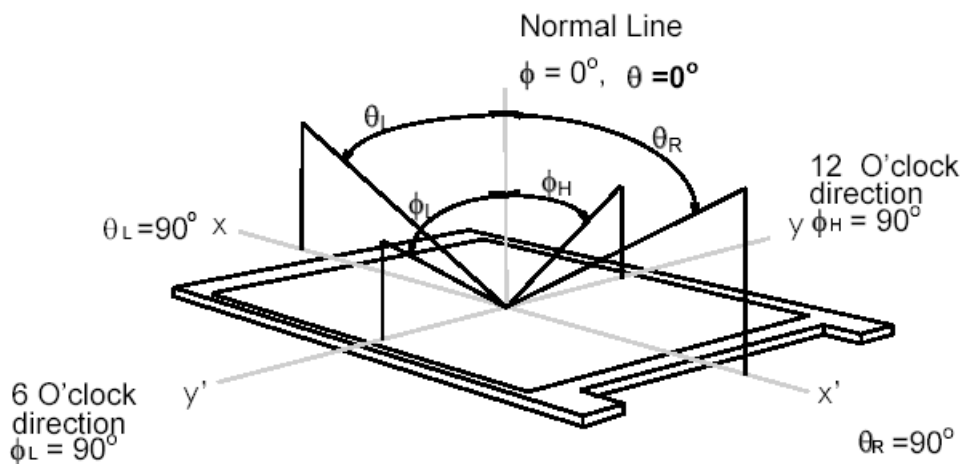

### 3. Functional Block Diagram

The following diagram shows the functional block of the 15 inch color TFT/LCD module:

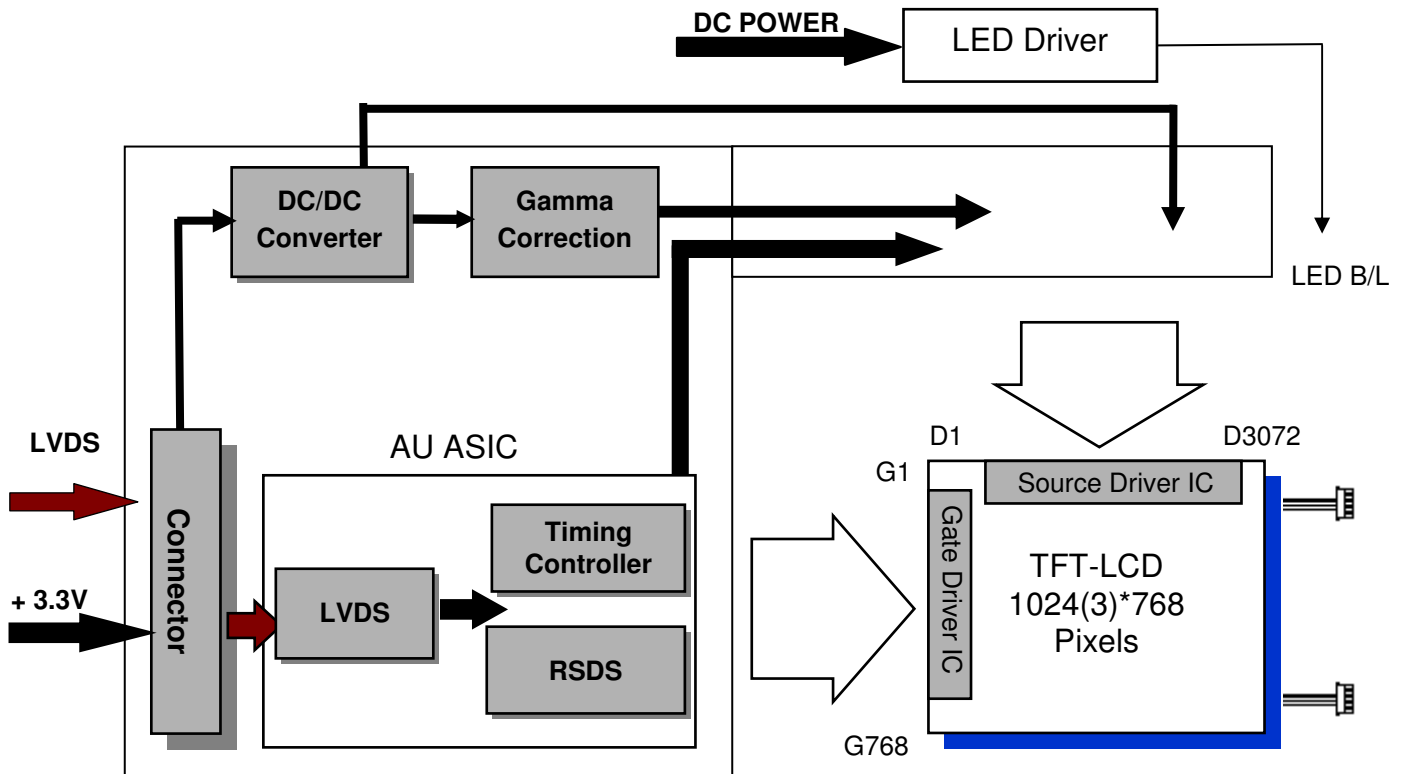

3804-F20N-06R / MSB240420E

SM06B-SRSS-TB(LF)(SN)

**Mating Type:** HRS DF14-20S-1.25C

SHR-06V-S-B

## 4. Absolute Maximum Ratings

### 4.1 Absolute Ratings of TFT LCD Module

Item	Symbol	Min	Max	Unit
Logic/LCD Drive Voltage	Vin	- 0.3	+4.0	[Volt]

### 4.2 Absolute Ratings of Environment

Item	Symbol	Min	Max	Unit
Operating Temperature	TOP	0	+65	[°C]
Operation Humidity	HOP	8	90	[%RH]
Storage Temperature	TST	-20	+65	[°C]
Storage Humidity	HST	8	90	[%RH]

Note: Maximum Wet-Bulb should be 39°C and no condensation.

\* 65 °C is panel surface temperature

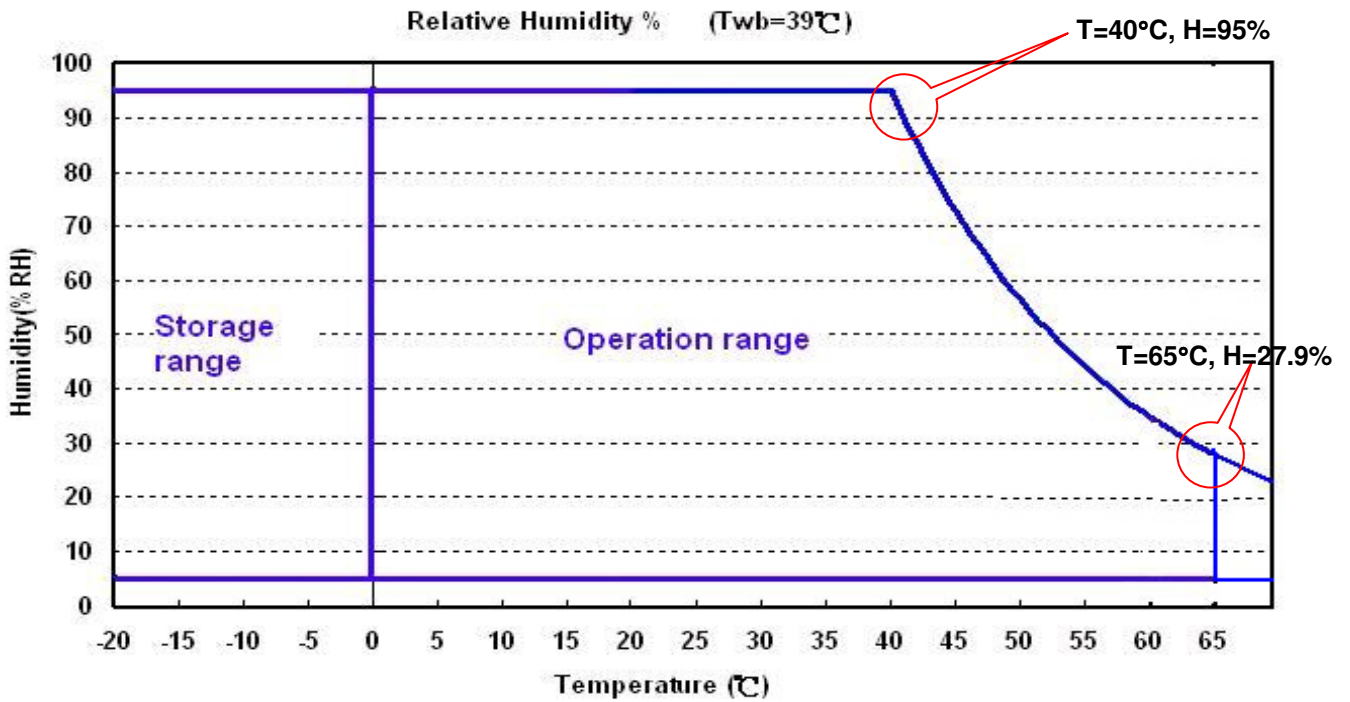

## 5. Electrical Characteristics

### 5.1 TFT LCD Module

#### 5.1.1 Power Specification

Symbol	Parameter	Min	Typ	Max	Units	Remark
VDD	Logic/LCD Drive Voltage	3.0	3.3	3.6	[Volt]	± 10%
IDD	VDD Current	-	550	660	[mA]	64 Gray Bar Pattern (VDD=3.3V, at 60Hz)
Irush	LCD Inrush Current	-	-	3	[A]	Note 1
PDD	VDD Power	-	1.9	2.2	[Watt]	64 Gray Bar Pattern (VDD=3.3V, at 60Hz)

Note 1: Measurement condition:

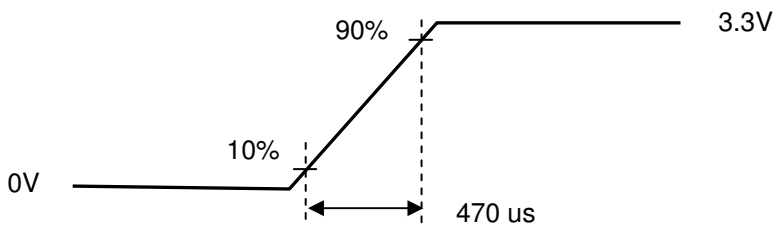
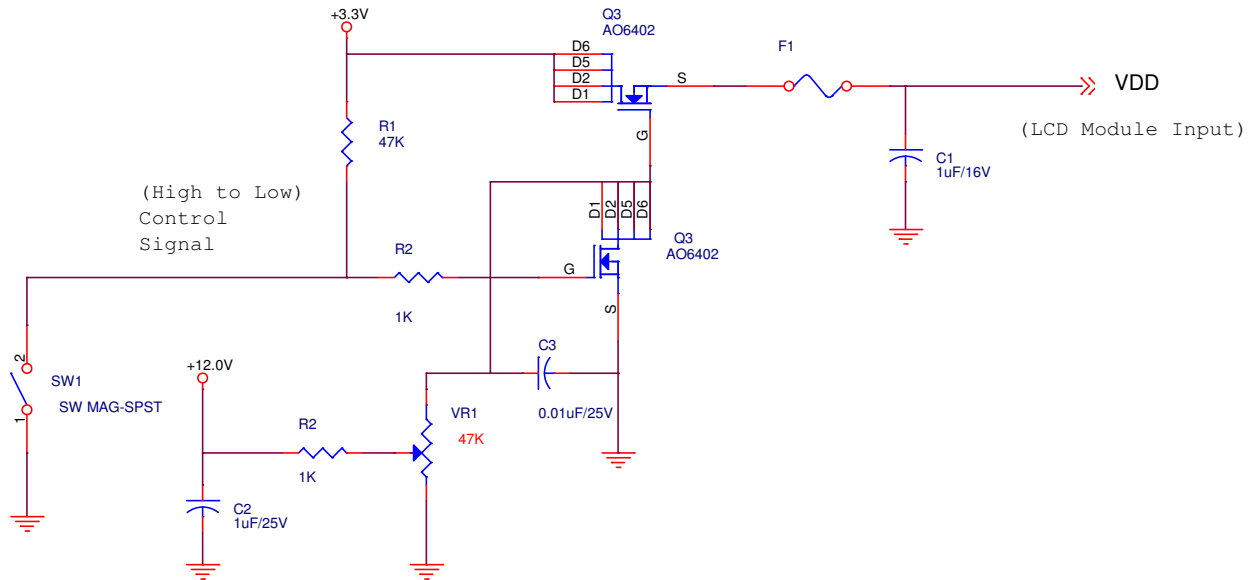

VDD rising time



64 Gray pattern

### 5.1.2 Signal Electrical Characteristics

Input signals shall be low or Hi-Z state when VDD is off.

Symbol	Item	Min.	Typ.	Max.	Unit	Remark
VTH	Differential Input High Threshold	-	-	100	[mV]	VCM=1.2V
VTL	Differential Input Low Threshold	-100	-	-	[mV]	VCM=1.2V
VID	Input Differential Voltage	100	400	600	[mV]	
VICM	Differential Input Common Mode Voltage	1.1		1.45	[V]	VTH/VTL=±100mV

Note: LVDS Signal Waveform.

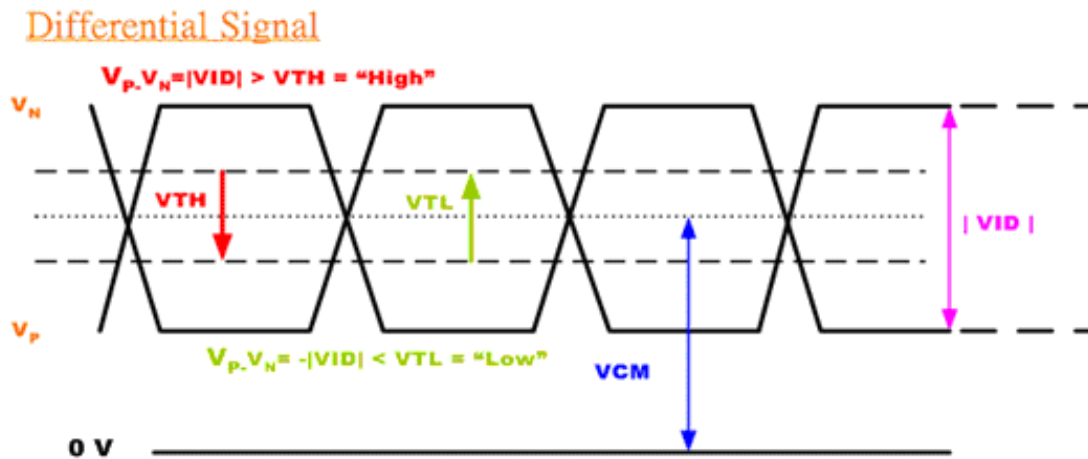

## 5.2 Backlight Unit

### 5.2.1 Parameter guideline for LED

Following characteristics are measured under stable condition using a LED driving board at 25°C (Room Temperature).

Symbol	Parameter	Min	Typ	Max	Unit	Remark
$I_F$	LED Forward Current	-	(80)		mA	$T_a = 25^\circ\text{C}$
$V_F$	LED Forward Voltage	-		-	Volt	$I_F = 80\text{mA}, T_a = -30^\circ\text{C}$
		-	(28.8)		Volt	$I_F = 80\text{mA}, T_a = 25^\circ\text{C}$
		-		-	Volt	$I_F = 80\text{mA}, T_a = 85^\circ\text{C}$
$P_{LED}$	LED Power	-	(6.912)	-	Watt	
Operating Life			(50000)		Hrs	$I_F = 80\text{mA}, T_a = 25^\circ\text{C}$

Note 1:  $T_a$  means ambient temperature of TFT-LCD module.

Note 2: If G150XG01 V2 module is driven by high current or at high ambient temperature & humidity condition. The operating life will be reduced.

Note 3: Operating life means brightness goes down to 50% initial brightness. Typical operating life time is estimated data.

## 6. Signal Characteristic

### 6.1 Pixel Format Image

Following figure shows the relationship between input signal and LCD pixel format.

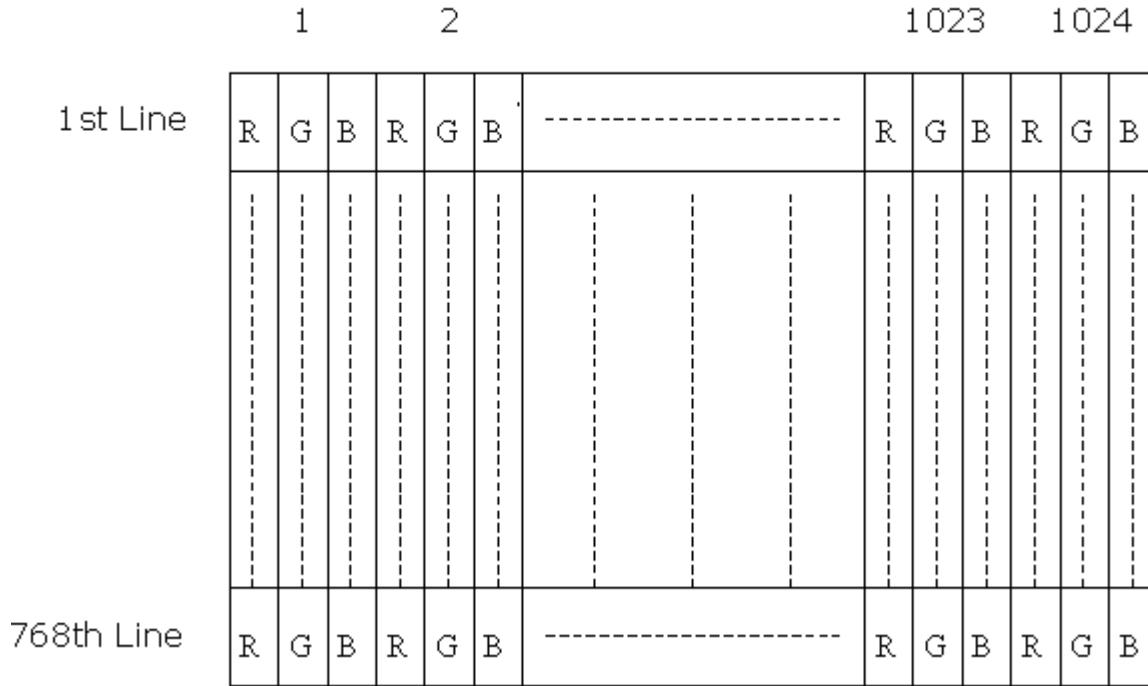

### 6.2 Scanning Direction

The following figures show the image seen from the front view. The arrow indicates the direction of scan.

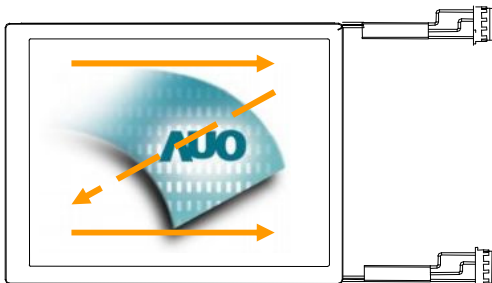

Fig. 1 Normal scan (Pin4, REV = Low or NC)

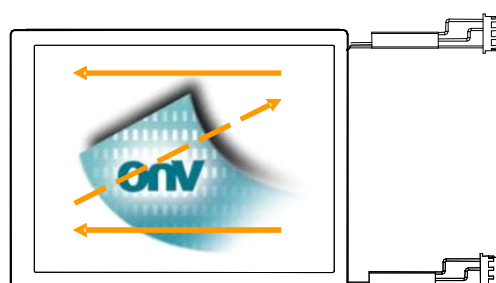

Fig. 2 Reverse scan (Pin4, REV = High)

### 6.3 Signal Description

The module using a pair of LVDS receiver SN75LVDS82(Texas Instruments) or compatible. LVDS is a differential signal technology for LCD interface and high speed data transfer device. Transmitter shall be SN75LVDS83(negative edge sampling) or compatible. The first LVDS port(RxOxxx) transmits odd pixels while the second LVDS port(RxExxx) transmits even pixels.

3804-F20N-06R (E&T) / MSB240420E(STM)		
Pin No.	Symbol	Description
1	VDD	Power Supply, 3.3V (typical)
2	VDD	Power Supply, 3.3V (typical)
3	VSS	Ground
4	REV	Reverse Scan selection *.Note1
5	Rin1-	- LVDS differential data input (R0-R5, G0)
6	Rin1+	+ LVDS differential data input (R0-R5, G0)
7	VSS	Ground
8	Rin2-	- LVDS differential data input (G1-G5, B0-B1)
9	Rin2+	+ LVDS differential data input (G1-G5, B0-B1)
10	VSS	Ground
11	Rin3-	- LVDS differential data input (B2-B5, HS, VS, DE)
12	Rin3+	+ LVDS differential data input (B2-B5, HS, VS, DE)
13	VSS	Ground
14	ClkIN-	- LVDS differential clock input
15	ClkIN+	+ LVDS differential clock input
16	GND	Ground
17	Rin4-	- LVDS differential data input (R6-R7, G6-G7,B6-B7)
18	Rin4+	- LVDS differential data input (R6-R7, G6-G7,B6-B7)
19	VSS	Ground
20	SEL68	Selection for 6 bits/8bits LVDS data input * <b>Note1</b>

Note 1: Input signals shall be in low status when VDD is off.

## 6.4 The Input Data Format

### 6.4.1 SEL68

**SEL68 = "High" or "NC" for 6 bits LVDS Input**

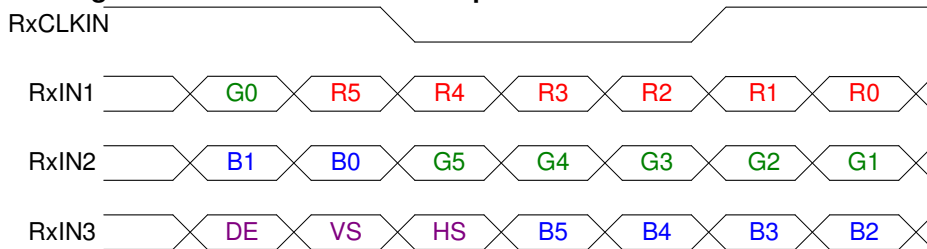

**SEL68 = "Low" for 8 bits LVDS Input**

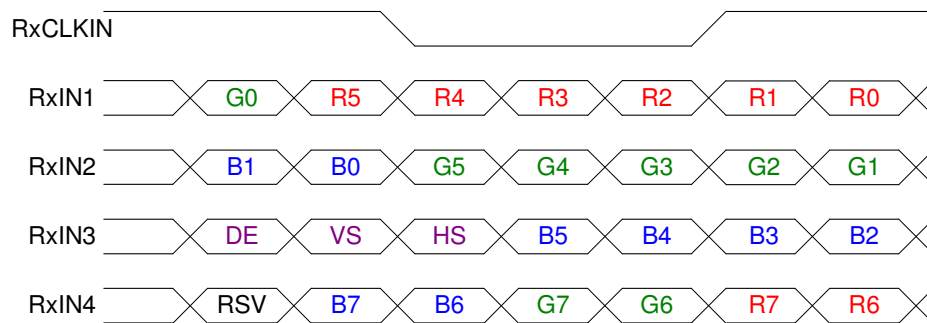

**Note1:** Please follow PSWG.

**Note2:** R/G/B data 7:MSB, R/G/B data 0:LSB

Signal Name	Description	Remark
R7	Red Data 7	Red-pixel Data  For 8Bits LVDS input MSB: R7 ; LSB: R0  For 6Bits LVDS input MSB: R5 ; LSB: R0
R6	Red Data 6	
R5	Red Data 5	
R4	Red Data 4	
R3	Red Data 3	
R2	Red Data 2	
R1	Red Data 1	
R0	Red Data 0	
G7	Green Data 7	Green-pixel Data  For 8Bits LVDS input MSB: G7 ; LSB: G0  For 6Bits LVDS input MSB: G5 ; LSB: G0
G6	Green Data 6	
G5	Green Data 5	
G4	Green Data 4	
G3	Green Data 3	
G2	Green Data 2	
G1	Green Data 1	
G0	Green Data 0	
B7	Blue Data 7	Blue-pixel Data  For 8Bits LVDS input MSB: B7 ; LSB: B0  For 6Bits LVDS input MSB: B5 ; LSB: B0
B6	Blue Data 6	
B5	Blue Data 5	
B4	Blue Data 4	
B3	Blue Data 3	
B2	Blue Data 2	
B1	Blue Data 1	
B0	Blue Data 0	
RxCLKIN	LVDS Data Clock	
DE	Data Enable Signal	When the signal is high, the pixel data shall be valid to be displayed.
VS	Vertical Synchronous Signal	
HS	Horizontal Synchronous Signal	

Note: Output signals from any system shall be low or Hi-Z state when VDD is off.

## 6.5 Interface Timing

### 6.5.1 Timing Characteristics

Signal	Parameter	Symbol	Min.	Typ.	Max.	Unit	
Clock Timing	Clock frequency	$1/T_{Clock}$	50	65	81	MHz	
Vsync Timing	Vertical Section	Period	$T_V$	776	806	1024	$T_{Line}$
		Active	$T_{VD}$	768	768	768	
		Blanking	$T_{VB}$	8	38	256	
Hsync Timing	Horizontal Section	Period	$T_H$	1054	1344	2048	$T_{Clock}$
		Active	$T_{HD}$	1024	1024	1024	
		Blanking	$T_{HB}$	30	320	1024	

Note: Frame rate is 60 Hz.

Note: DE mode.

Note : Typical value refer to VESA STANDARD

### 6.5.2 Input Timing Diagram

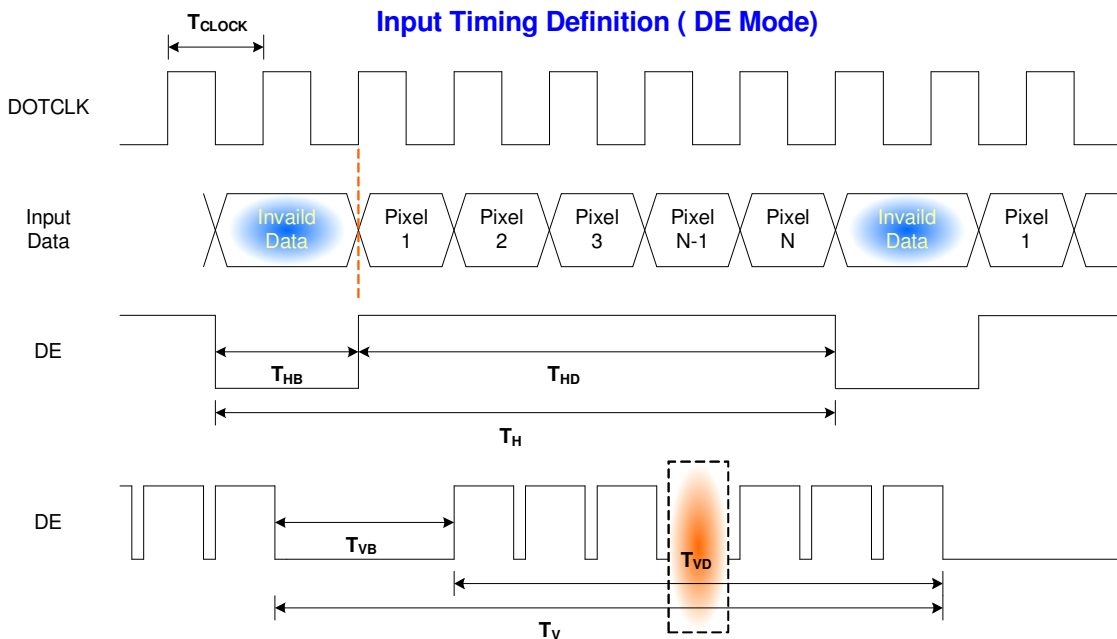

## 6.6 Power ON/OFF Sequence

VDD power and lamp on/off sequence is as below. Interface signals are also shown in the chart. Signals from any system shall be Hi-Z state or low level when VDD is off.

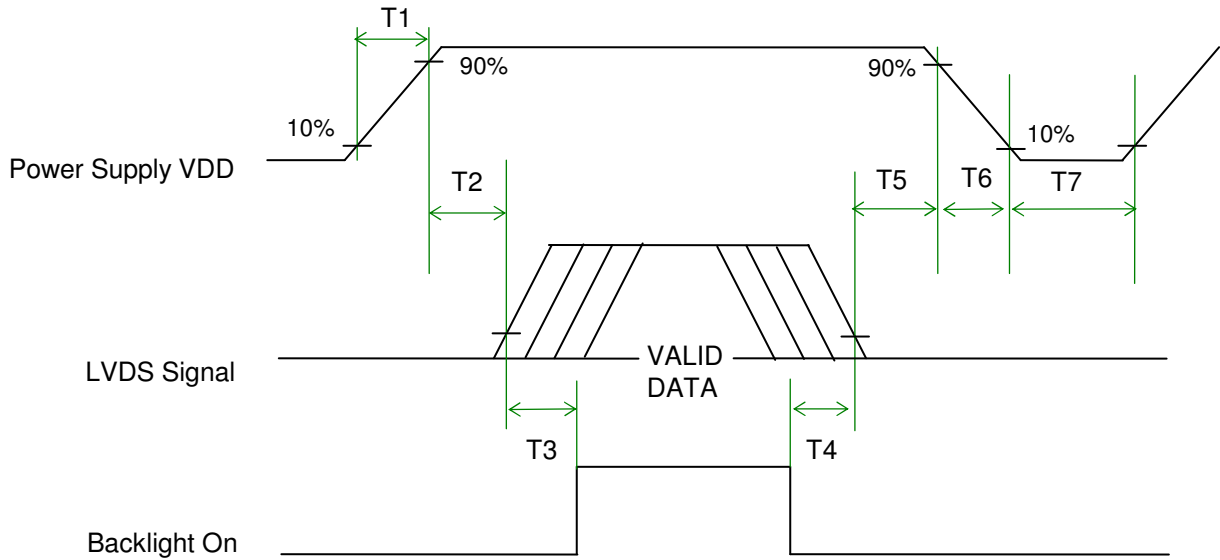

### Power ON/OFF sequence timing

Parameter	Value			Units
	Min.	Typ.	Max.	
T1	0.5	-	10	ms
T2	0	40	50	ms
T3	200	-	-	ms
T4	200	-	-	ms
T5	0	16	50	ms
T6	0	-	10	ms
T7	1000	-	-	ms

The above on/off sequence should be applied to avoid abnormal function in the display. Please make sure to turn off the power when you plug the cable into the input connector or pull the cable out of the connector.

## 7. Connector & Pin Assignment

Physical interface is described as for the connector on module. These connectors are capable of accommodating the following signals and will be following components.

### 7.1 TFT LCD Module: LVDS Connector

<b>Connector Name / Designation</b>	<b>Signal Connector</b>
Manufacturer	E&T or compatible
Connector Model Number	3804-F20N-06R / MSB240420E
Adaptable Plug	HRS DF14-20S-1.25C

Pin#	Signal Name	Pin#	Signal Name
1	VDD	2	VDD
3	VSS	4	REV
5	Rin1-	6	Rin1+
7	VSS	8	Rin2-
9	Rin2+	10	VSS
11	Rin3-	12	Rin3+
13	VSS	14	ClkIN-
15	ClkIN+	16	GND
17	Rin4-	18	Rin4+
19	VSS	20	SEL68

## 7.1.1 Connector Illustration

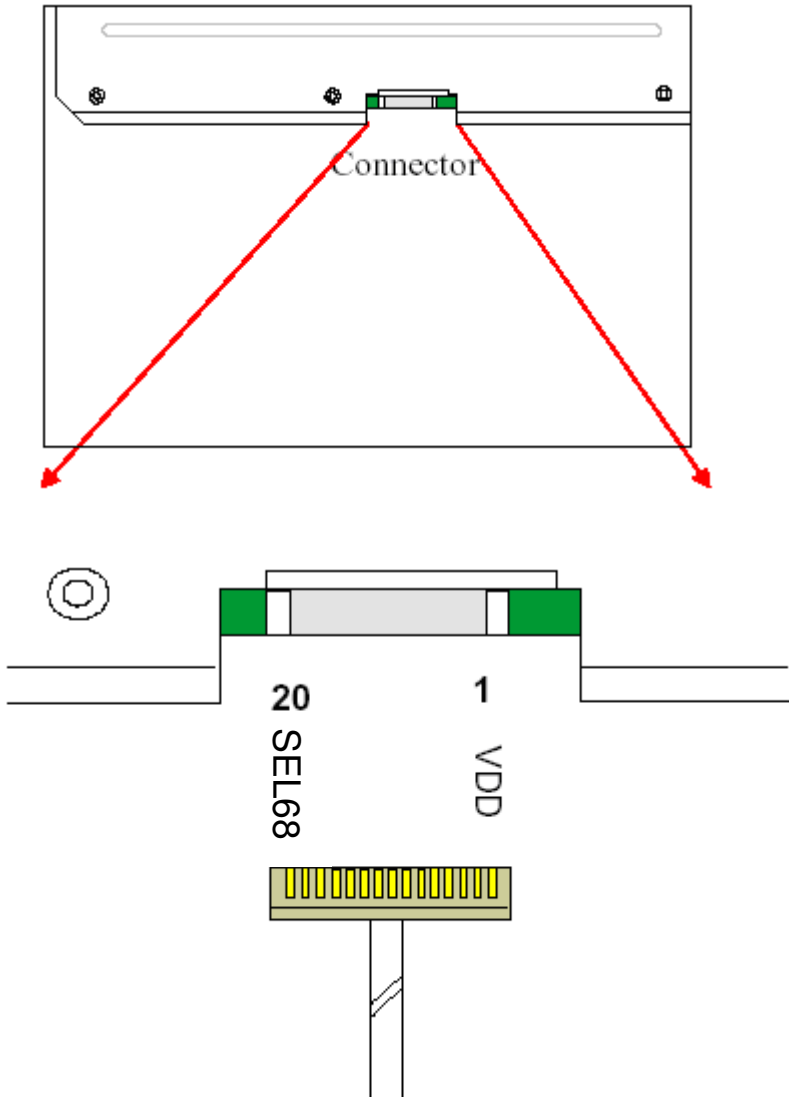

## 7.2 Backlight Unit: Lamp Connector

<b>Connector Name / Designation</b>	<b>Lamp Connector</b>
Manufacturer	JST or compatible
Connector Model Number	SM06B-SRSS-TB(LF)(SN) or compatible
Mating Model Number	SHR-06V-S-B or compatible

## 7.3 Lamp Connector Pin Assignment

Pin#	Symbol	Signal Name
1	+ch3	Power supply for LED (Ch3 High voltage side)
2	+ch2	Power supply for LED (Ch2 High voltage side)
3	+ch1	Power supply for LED (Ch1 High voltage side)
4	-ch1	Power supply for LED (Ch1 Low voltage side)
5	-ch2	Power supply for LED (Ch2 Low voltage side)
6	-ch3	Power supply for LED (Ch3 Low voltage side)

## 8. Reliability Test Criteria

Items	Required Condition	Note
Temperature Humidity Bias	50°C /80%,300 hours	
High Temperature Operation	60°C ,300 hours	
Low Temperature Operation	0°C ,300 hours	
Hot Storage	65°C ,300 hours	
Cold Storage	-20°C ,300 hours	
Thermal Shock Test	-20°C/30 min ,60°C/30 min ,100cycles	
Shock Test (Non-Operating)	50G,20ms,Half-sine wave,( ±X, ±Y, ±Z)	
Vibration Test (Non-Operating)	1.5G, (10~200Hz, P-P) 30 mins/axis (X, Y, Z)	
On/off test	On/10 sec, Off/10 sec, 30,000 cycles	
ESD	Contact Discharge: ± 8KV, 150pF(330Ω ) 1sec, 8 points, 25 times/ point Air Discharge: ± 15KV, 150pF(330Ω ) 1sec, 8 points, 25 times/ point	Note 1

Note1: According to EN61000-4-2, ESD class B: Some performance degradation allowed. No data lost

- . Self-recoverable. No hardware failures.

## 9. Mechanical Characteristics

### 9.1 LCM Front View and Rear View

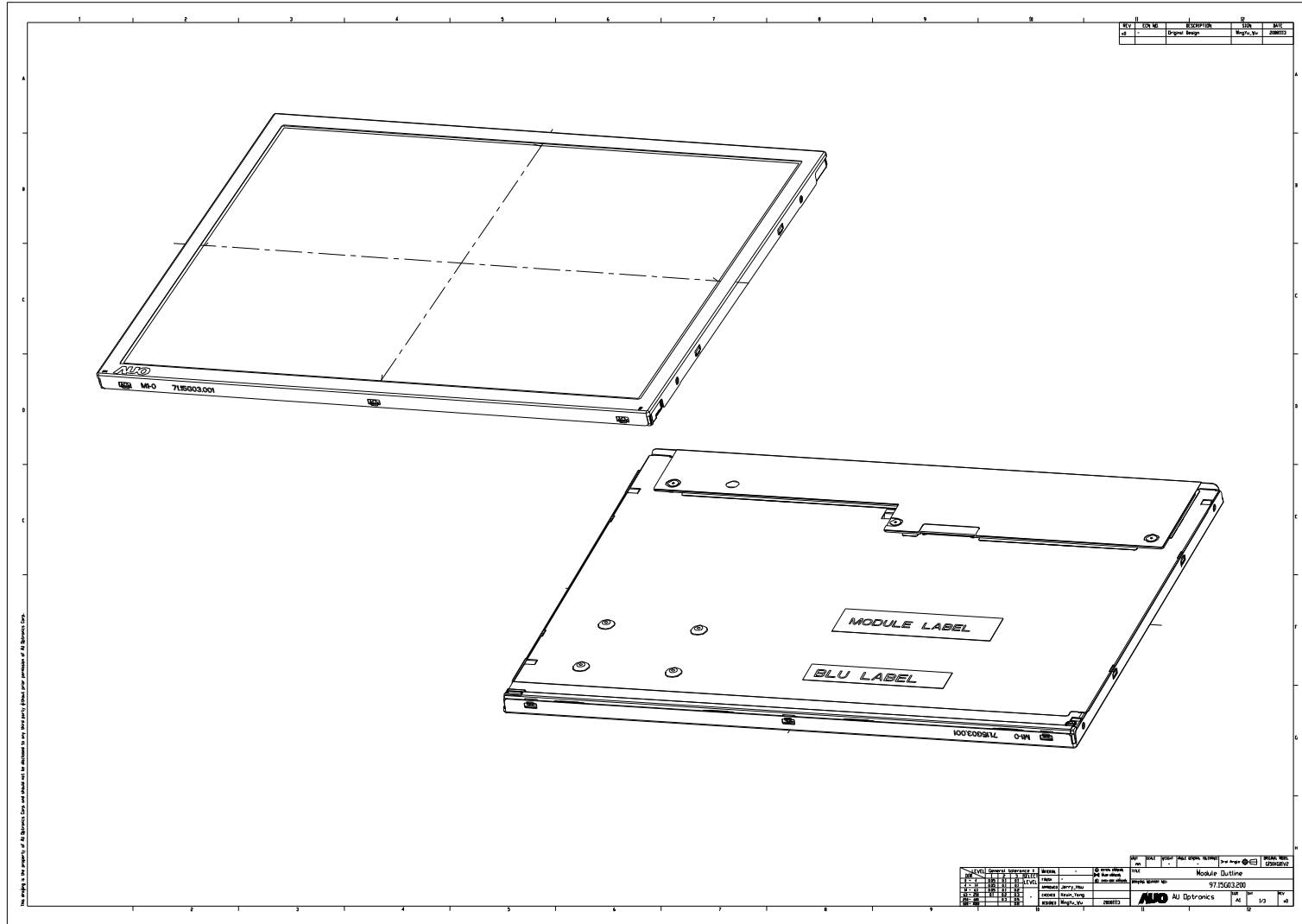

## 9.2 LCM Outline Dimension (Front View)

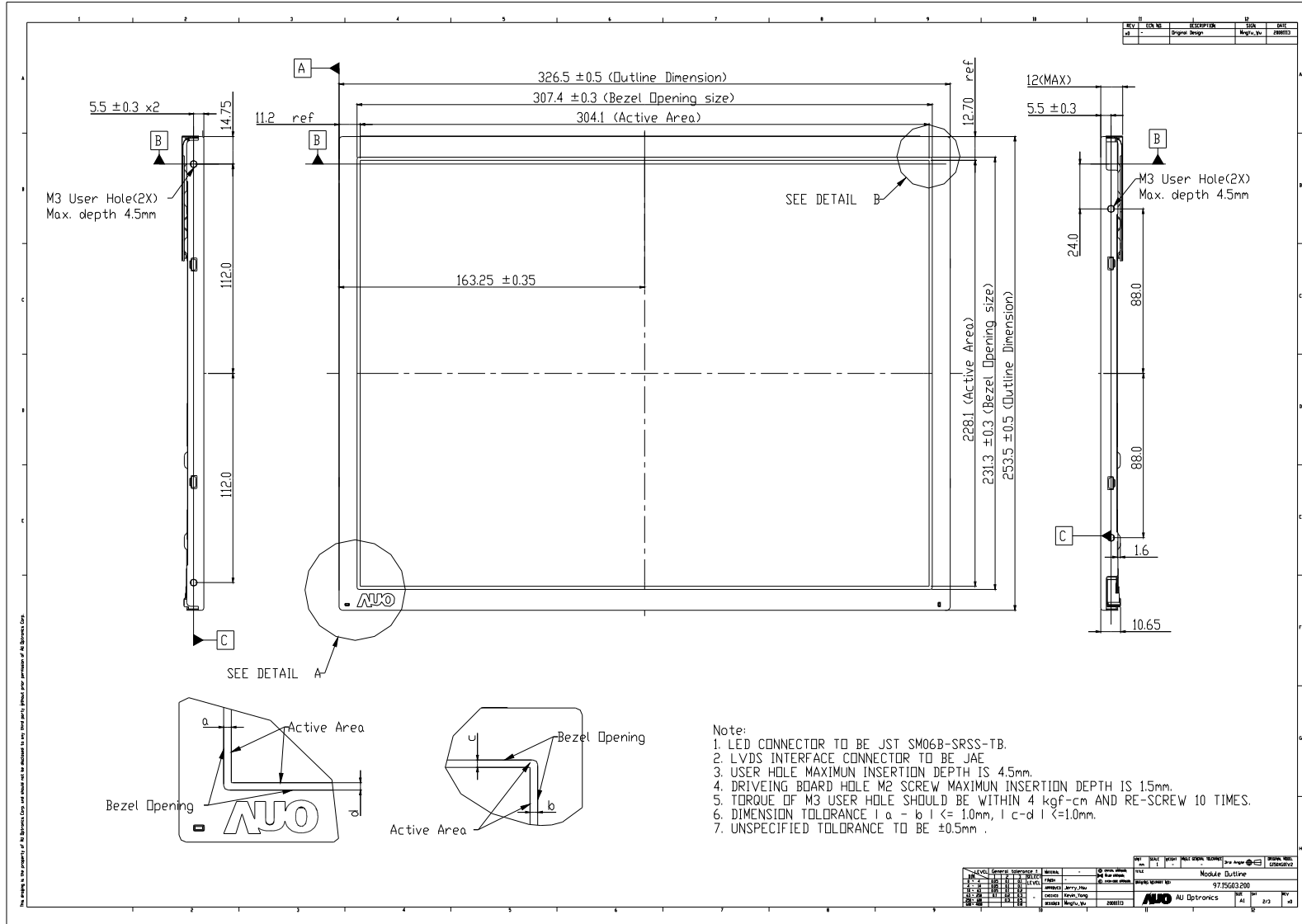

### 9.3 LCM Outline Dimension (Rear View)

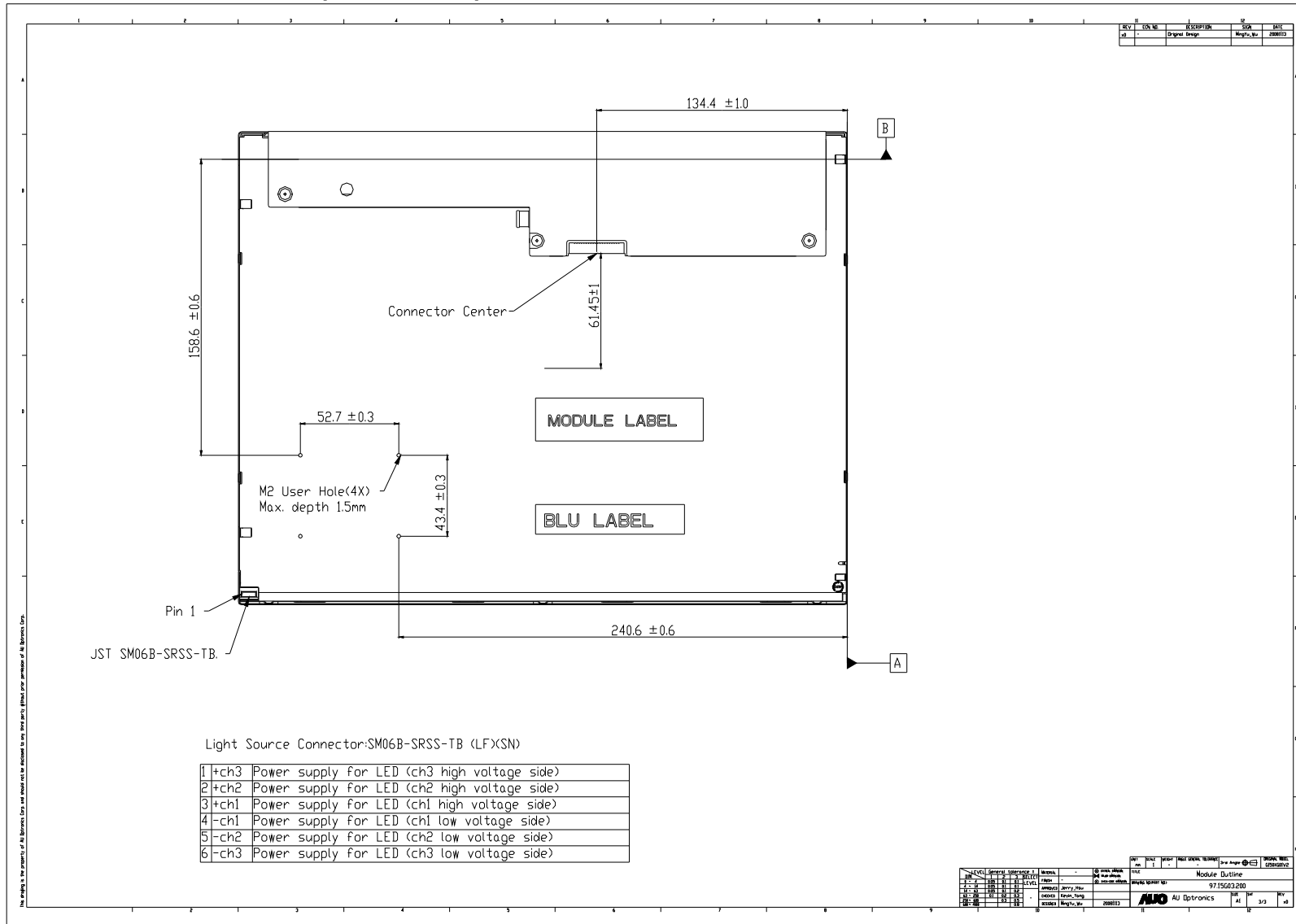

## 10. Label and Packaging

### 10.1 Shipping Label (on the rear side of TFT-LCD display)



### 10.2 Carton Package

- Max capacity: 15 TFT-LCD module per carton (12pcs \* 1 layers)
- Max weight: 20 kg per carton
- Outside dimension of carton: 375(L)mm\* 430(W)mm\* 353(H)mm

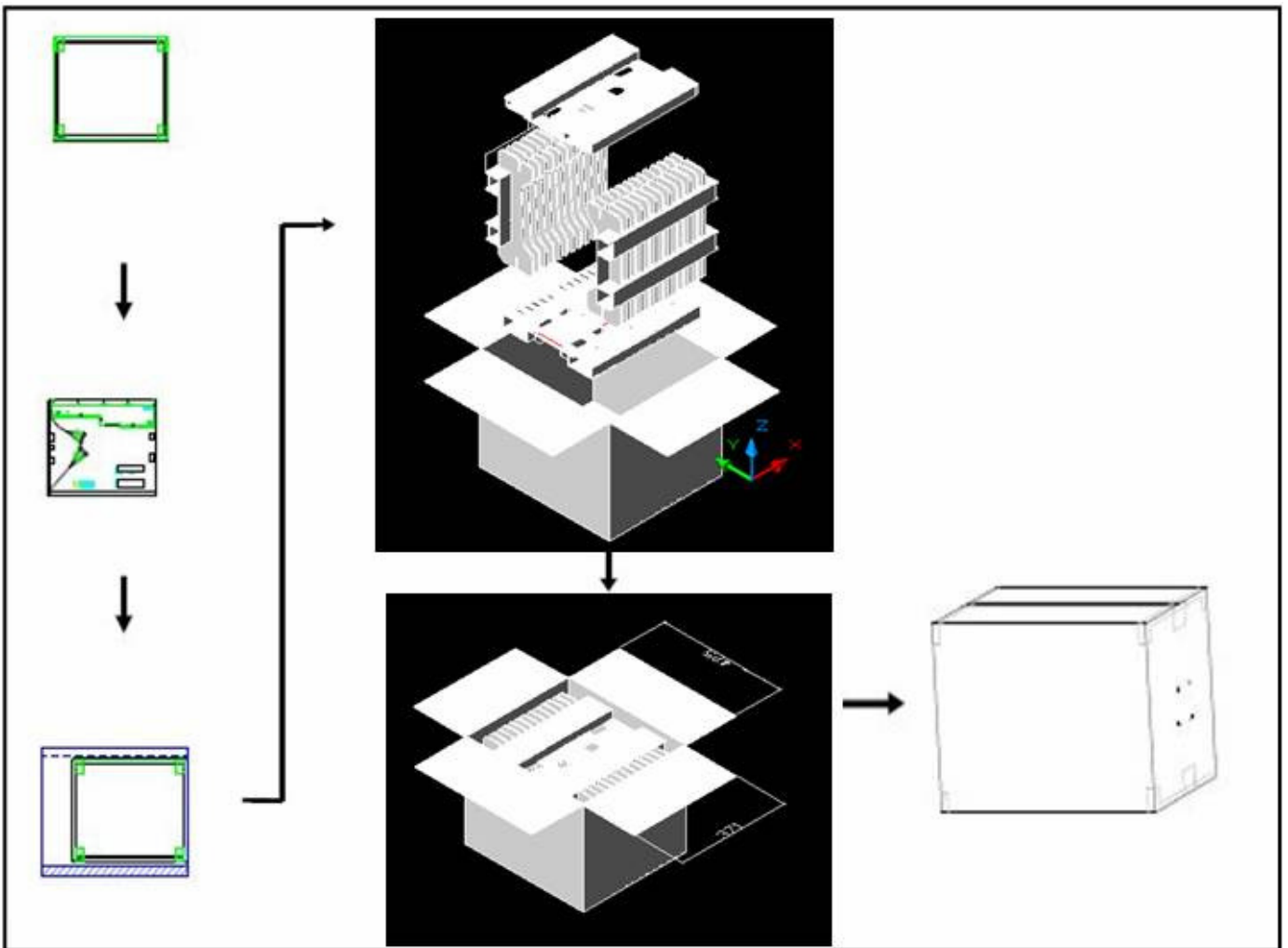

## 11 Safety

### 11.1 Sharp Edge Requirements

There will be no sharp edges or comers on the display assembly that could cause injury.

### 11.2 Materials

#### 11.2.1 Toxicity

There will be no carcinogenic materials used anywhere in the display module. If toxic materials are used, they will be reviewed and approved by the responsible AUO toxicologist.

#### 11.2.2 Flammability

All components including electrical components that do not meet the flammability grade UL94-V1 in the module will complete the flammability rating exception approval process.

The printed circuit board will be made from material rated 94-V1 or better. The actual UL flammability rating will be printed on the printed circuit board.

### 11.3 Capacitors

If any polarized capacitors are used in the display assembly, provisions will be made to keep them from being inserted backwards.

### 11.4 National Test Lab Requirement

The display module will satisfy all requirements for compliance to:

**UL 1950, First Edition**

U.S.A. Information Technology Equipment