

Product Specification

SPECIFICATION

For

APPROVAL

(◆) Preliminary Specification

() Final Specification

Title	20.1" UXGA TFT LCD
-------	--------------------

BUYER NAME	
MODEL NAME	

SUPPLIER	LG.Philips LCD Co.,Ltd.
MODEL NAME	LM201U1
SUFFIX	A1

* When you obtain standard approval ,
 please use the above model name without suffix.

SIGNATURE	DATE
/	_____
/	_____
/	_____

APPROVED BY	DATE
S.H. Kang/G. Manager	_____
REVIEWED BY K.G. Park/S. Engineer B.K. Kim/S. Engineer	_____
PREPARED BY S.Y. Yi/Engineer K.H. Moon/Engineer	_____
Product Engineering Dept. LG.Philips LCD Co.,Ltd.	

The preliminary document is subject to change without prior notice.

Please return 1 copy with your signature and comments.

CONTENTS

NO.	ITEM	Page
-	COVER	1
-	CONTENTS	2
-	RECORD of REVISIONS	3
1.	GENERAL DESCRIPTIONS	4
2.	ABSOLUTE MAXIMUM RATINGS	5
3.	ELECTRICAL SPECIFICATIONS	6
3-1.	ELECTRICAL CHARACTERISTICS	6
3-2.	INTERFACE CONNECTIONS	7
3-3.	SIGNAL TIMING SPECIFICATIONS	10
3-4.	SIGNAL TIMING WAVEFORMS	11
3-5.	COLOR INPUT DATA REFERENCES	12
3-6.	POWER SEQUENCES	13
4.	OPTICAL SPECIFICATIONS	14
5.	MECHANICAL CHARACTERISTICS	17
5-1	FRONT VIEW	18
5-2	REAR VEIW	19
6.	RELIABILITY	20
7.	INTERNATIONAL STANDARDS	21
7-1.	SAFETY	21
7-2.	EMC	21
8.	PACKING	22
8-1	DESIGNATION OF LOT MARK	22
8-2	PACKING FORM	22
9.	PRECAUTIONS	23
-	APPENDIX 1. REQUIRED SIGNAL ASSIGNMENT FOR Si1160 TMDS Receiver	25

Product Specification

Record of Revisions

Version No.	Date	Page	Descriptions
0.0	JUL. 10, 2000	-	First Draft, Preliminary
0.1	SEP. 06, 2000		Second Draft, Preliminary
0.2	SEP. 27, 2000		Third Draft, Preliminary
0.3	OCT. 19, 2000		Forth Draft, Preliminary

Product Specification

1. General Descriptions

The LM201U1 LCD is a Color Active Matrix Liquid Crystal Display with an integral Cold Cathode Fluorescent Lamp(CCFL) back light system. The matrix employs a-Si Thin Film Transistor as the active element. It is a transmissive type display operating in the normally black mode. This TFT-LCD has a 20.1 inch diagonally measured active display area with UXGA resolution(1200 vertical by 1600 horizontal pixel array). Each pixel is divided into Red, Green and Blue sub-pixels or dots which are arranged in vertical stripes. Gray scale or the luminance of the sub-pixel color is determined with a 8-bit gray scale signal for each dot, thus, presenting a palette of more than 16,777,216 colors.

The LM201U1 has been designed to apply the TMDSTM(Transition Minimized differential Signaling) as the interface method to enables a simple and low-cost implementation in both the host and monitor.

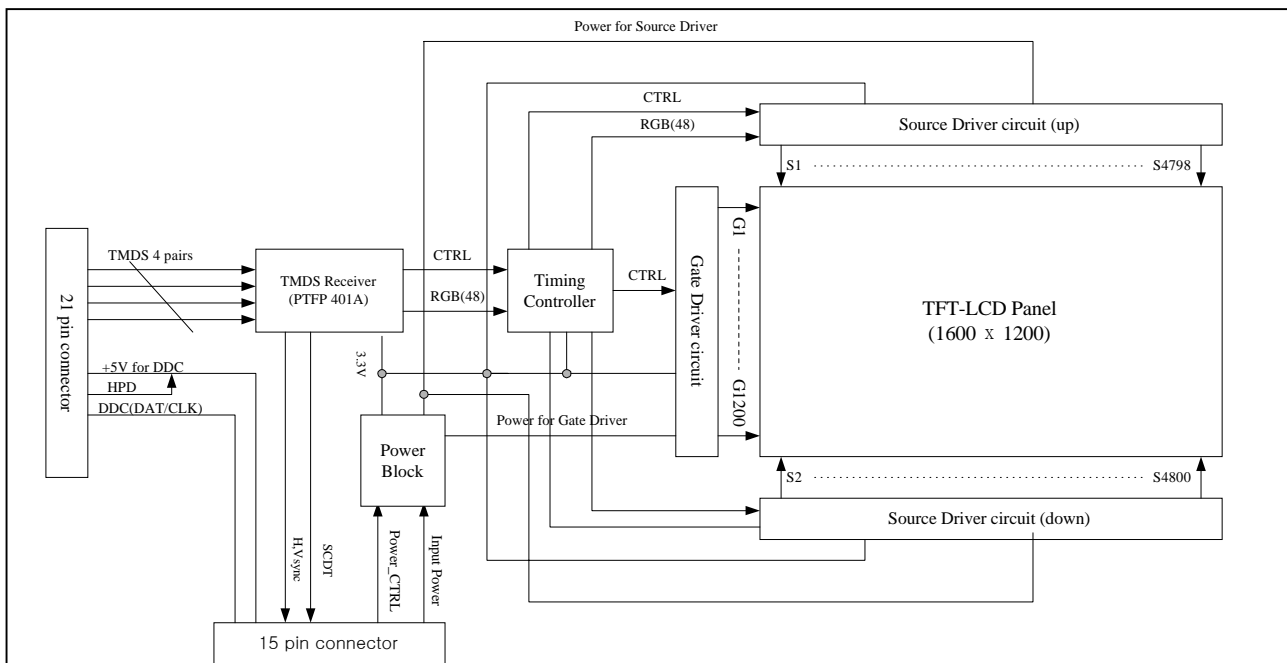

General Display Characteristics

Followings are general features of the model LM201U1 LCD;

Active display area	20.1 inches(51cm) diagonal
Outsize dimensions	467.80W x 361.0H x 32.0Tmm
Pixel pitch	0.255 mm × 0.255 mm
Pixel format	1600 horiz. By 1200 vert. pixels
	RGB vertical stripe arrangement
Color depth	8-bit, 16,777,216 colors
Display operating mode	transmissive mode, normally black
Luminance,White	250 cd/m ² (Typ.)
Power Consumption	Total 43.2Watt(Typ.)
Weight	4100g (Typ.)
Surface treatments	hard coating(3H), anti-glare treatment of the front polarizer
Interface method	TMDSTM interface
Lamps	Six CCFL's(Cold Cathode Fluorescent Lamp)

Product Specification
3. Electrical Specifications
3-1. Electrical Characteristics

The LM201U1 requires two power inputs. One input is employed to power the LCD electronics and to drive the voltages to drive the TFT array and liquid crystal. And the second input which powers the CCFL, is typically generated by an inverter. The inverter is an external unit to the LCD.

Table 2 Electrical Characteristics:

Parameter	Symbol	Values			Units	Notes
		Min.	Typ.	Max.		
MODULE:						
Power Supply Input Voltage	V _{AA}	17.1	18.0	18.9	Vdc	1
Power Supply Input Current	I _{AA}		0.53	0.8	A	
Power Control Logic Input High	V _{IH}	3.0	3.3	3.6	Vdc	
Power Control Logic Input Low	V _{IL}	-	-	0.8	Vdc	
Control Logic Output High	V _{OH}	2.5	-	-	Vdc	
Control Logic Output Low	V _{OL}	-	-	0.5	Vdc	
Differential Impedance	Z _m	90	100	110	Ohm	2
Rush Current	I _{Rush}	-	-	3	A	3
LAMP (each CCFL)						
Operating voltage	V _{BL}	740	750	920	V _{RMS}	4
Operating Current	I _{BL}	3.0	7.5	8.0	mA	
Established Starting Voltage	V _S					5
at 25°C		-	-	1080	V _{RMS}	
at 0°C		-	-	1500	V _{RMS}	
Operating Frequency	F _{BL}	40	50	60	KHz	6
Power Consumption(6 CCFL's)	P _{BL}	-	33.8	37.2	Watts	7
Discharge Stabilization Time	T _S	-	-	3	Minutes	8
Life time		TBD	-	-	Hours	9

- Notes: 1. The input current shall be measured at V_{DD} of 18.0Vdc at 25°C, refresh rate of 60Hz, and pixel clock frequency of 162MHz under full white pattern(255gray).
2. This impedance value is needed to proper display and measured from TMDS Tx to the mating connector.
3. The duration of rush current is about 20ms.
4. The variance of the voltage is ± 10%.
5. The voltage above V_S should be applied to the lamps for more than 1second for start-up. Otherwise, the lamps may not turn on.
6. The output of the inverter must have symmetrical(negative and positive) voltage waveform and symmetrical current waveform.(Unsymmetrical ratio is less than 10%) Please do not use the inverter which has unsymmetrical voltage and unsymmetrical current and spike wave. Lamp frequency may produce interference with horizontal synchronous frequency and as a result this may cause beat on the display. Therefore lamp frequency shall be as away as possible from the horizontal synchronous frequency and from its harmonics in order to prevent interference.
7. The lamp power consumption shown above does not include loss of external inverter. This value is measured at the typical lamp current and variance voltage ± 10% of the typical operating voltage.
8. Let's define the brightness of the lamp after being lighted for 5 minutes as 100%. T_S is the time required for the brightness of the center of the lamp to be no less than 95%.
9. The life time is defined as the time at which brightness of lamp is 50% compare to that of initial value at the typical lamp current on condition of continuous operating at 25±2°C.

Product Specification

3-2. Interface Connections

This LCD employs three kinds of interface connections. A 21 pin connector is used for TMDS signals from the host computer. A 15-pin connector is used for LCD module power and LCM controls signal from external monitor control circuits. And four connectors, a three pin and two pin connector, are used for the integral backlight system.

3-2-1. Signal Interface

The TMDS signal interface connector is FI-WE21P-HF-E by JAE.

Interface chip in host side, must be used TMDS™, part No. Sil160, designed by Silicon Image Inc., or its equivalent.

The pin configuration for the 21 pin connector is shown in the table below.

Table 3 21PIN CONNECTOR (CNC1) PIN CONFIGURATION

Pin	Symbol	Description	Pin	Symbol	Description
1	TX1+	TMDS positive differential output (channel1)	11	TX2+	TMDS positive differential output (channel2)
2	TX1-	TMDS negative differential output (channel1)	12	TX2-	TMDS negative differential output (channel2)
3	SHLD1	Shield for TMDS channel 1	13	SHLD2	Shield for TMDS channel 2
4	SHLDC	Shield for TMDS clock	14	SHLD0	Shield for TMDS channel 0
5	TXC+	TMDS positive differential output (reference clock)	15	TX0+	TMDS positive differential output (channel 0)
6	TXC-	TMDS negative differential output (reference clock)	16	TX0-	TMDS negative differential output (channel 0)
7	GND	Logic Ground	17	NC	Logic Ground
8	+5V	Logic +5V Supply (See note 2)	18	HPD	Hot Plug Detection (See note 3)
9	NC	No Connection	19	DDC_DAT	DDC2B Data (See note 4)
10	NC	No Connection	20	DDC_CLK	DDC2B Clock (See note 5)
			21	NC	No connection

1. Interface chips
 - 1.1 LCD : PTFP 401APZP (TI)
2. Connector
 - 2.1 LCD : FI-WE21P-HF-E
 - 2.2 Mating : FI-W21S or FI-W21M or compatible
 - 2.3 Connector pin arrangement



- Notes:
1. All shield pins and GND(ground) pin should be connected together and should also be connected to the LCD's metal frame.
 2. This +5V is only for external monitor control circuits and directly connected to 15 pin connector. The specifications for this source are the same as those defined in the VESA DDC Standard V3.0(+5V± 5%, 50mA minimum, 1.0A maximum).
 3. This pin is internally connected to pin 8 (+5V) in LCM circuits.
 - 4, 5. These pins are only for external monitor control circuits and directly connected to 15 pin connector.
 6. Refer to appendix 1 regarding TMDS signal mapping.

Product Specification

3-2-2. Power Interface

A 15 pin connector for external monitor control circuits, is a model 53261 manufactured by Molex. The mating connector part number is 51021 or its equivalent. The pin configuration for this connector is shown in the table below.

Table 4 15 PIN CONNECTOR (CNC2) PIN CONFIGURATION

Pin	Symbol	Description	Notes
1	GND	Ground	1
2	PWR_CTRL	LCM power control input signal Low : LCM power down except TMDS receiver High : Normal operation mode	2
3	GND	Ground	
4	V _{AA}	LCM power supply, +18V± 5%	
5	V _{AA}	LCM power supply, +18V± 5%	
6	GND	Ground	
7	H _{SYNC}	H _{SYNC} out from TMDS receiver to system	
8	V _{SYNC}	V _{SYNC} out from TMDS receiver to system	
9	GND	Ground	
10	SCDT	Sync Detect signal out from TMDS receiver to system	3
11	NC	No connection (Reserved)	
12	+5V_DDC	+5V out for DDC	4
13	SDA	DDC data line out	
14	SCL	DDC clock line out	
15	GND	Ground	

Connector pin arrangement

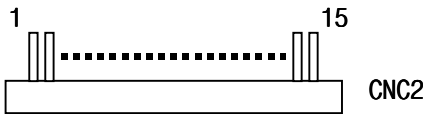

- Notes:
1. All GND(ground) pins should be connected together and should also be connected to the LCD's metal frame.
 2. LCM power control input signal for power saving mode. If this pin is held low state, LCM goes to power saving mode .
 3. SCDT to indicate link activity
 4. Pin 12, 13, 14 are for DDC2B communication between host computer and external monitor control circuits. These pins are directly connected to 21 pin connector.

Product Specification

3-3.Signal Timing Specifications

This is signal timing required at the input of the TMDS transmitter. All of the interface signal timing should be satisfied with the following specifications for it's proper operation.

Table 6 Timing Table

ITEM	SYMBOL	MIN.	TYP.	MAX.	UNIT	NOTES	
Dclk	Period	t_{CLK}	6.13	6.17	6.21	ns	162MHz
Hsync	Period	t_{HP}	2144	2160	2176	t_{CLK}	1
	Width	t_{WH}	192	192	192		
Vsync	Period	t_{VP}	1240	1250	1260	t_{HP}	
	Frequency	f_V	60	60	60	Hz	
	Width	t_{WV}	3	3	3	t_{HP}	2
DE (Data Enable)	Horizontal Valid	t_{HV}	1600	1600	1600	t_{CLK}	
	Horizontal Back Porch	t_{HBP}	304	304	304		
	Horizontal Front Porch	t_{HFP}	48	64	80		
	Horizontal Blank	-	544	~	576		$t_{WH} + t_{HBP} + t_{HFP}$
	Vertical Valid	t_{VV}	1200	1200	1200	t_{HP}	
	Vertical Back Porch	t_{VBP}	36	46	56		
	Vertical Front Porch	t_{VFP}	1	1	1		
	Vertical Blank	-	40	~	60		$t_{WV} + t_{VBP} + t_{VFP}$

- Notes: 1. Horizontal sync shall be active high.
2. Vertical sync shall be active high.

Product Specification

3-4. Signal Timing Waveforms

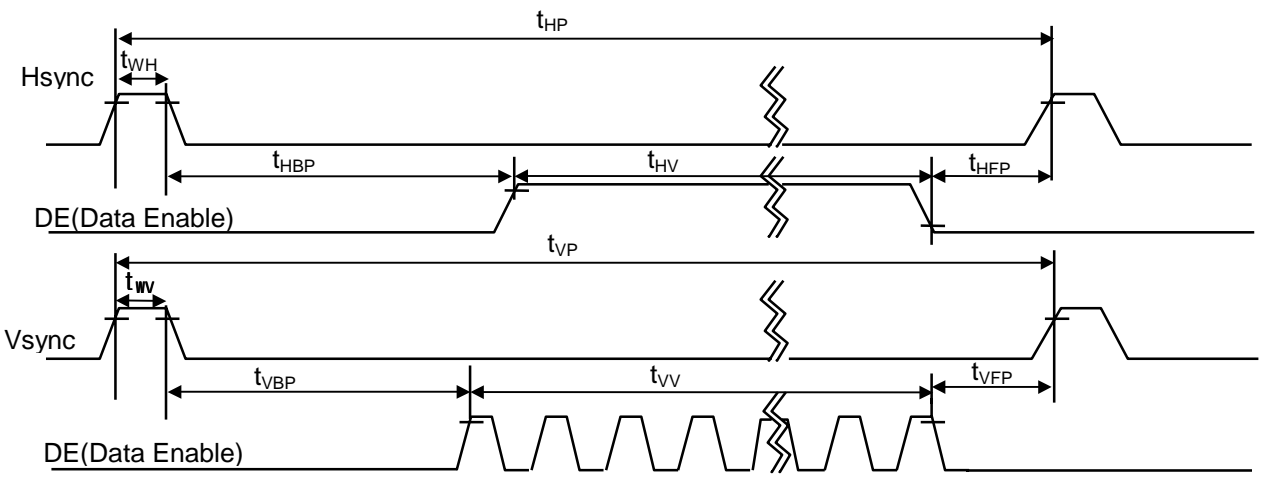
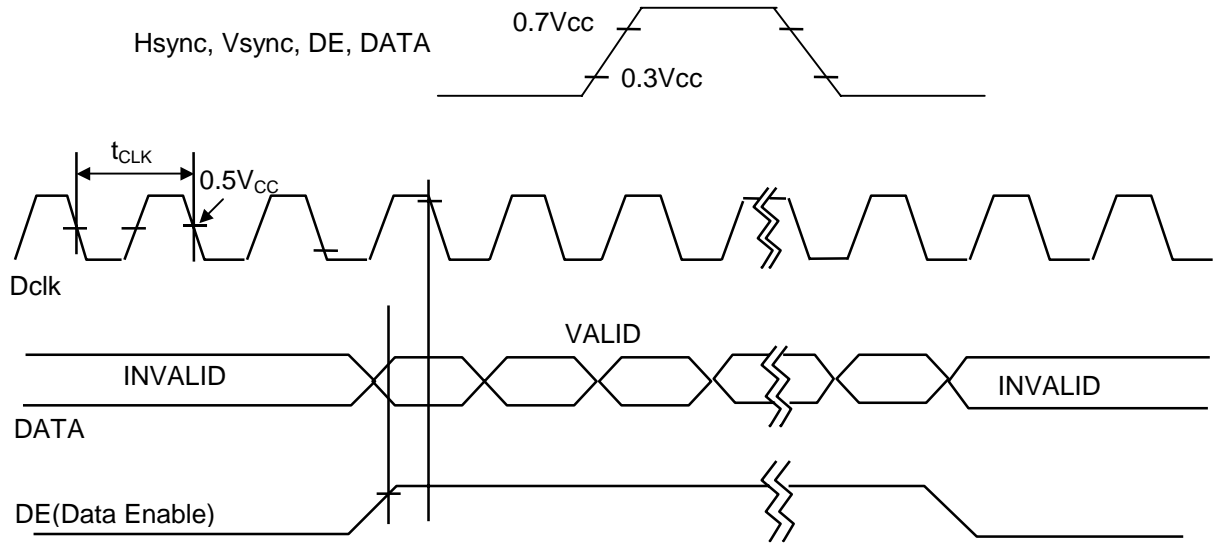

Product Specification

3-5. Color Input Data References

The brightness of each primary color(red, green and blue) is based on the 8-bit gray scale data input for the color; the higher the binary input, the brighter the color. The table below provides a reference for color versus data input.

Table 7 Color Data Reference

Color		Input Color Data																							
		Red								Green								Blue							
		MSB				LSB				MSB				LSB				MSB				LSB			
		R7	R6	R5	R4	R3	R2	R1	R0	G7	G6	G5	G4	G3	G2	G1	G0	B7	B6	B5	B4	B3	B2	B1	B0
Basic Colors	Black	0	0	0	0	0	0	0	0	0	0	0	0	0	0	0	0	0	0	0	0	0	0	0	0
	Red(255)	1	1	1	1	1	1	1	1	0	0	0	0	0	0	0	0	0	0	0	0	0	0	0	0
	Green(255)	0	0	0	0	0	0	0	0	1	1	1	1	1	1	1	1	0	0	0	0	0	0	0	0
	Blue(255)	0	0	0	0	0	0	0	0	0	0	0	0	0	0	0	0	1	1	1	1	1	1	1	1
	Cyan	0	0	0	0	0	0	0	0	1	1	1	1	1	1	1	1	1	1	1	1	1	1	1	1
	Magenta	1	1	1	1	1	1	1	1	0	0	0	0	0	0	0	0	1	1	1	1	1	1	1	1
	Yellow	1	1	1	1	1	1	1	1	1	1	1	1	1	1	1	1	0	0	0	0	0	0	0	0
	White	1	1	1	1	1	1	1	1	1	1	1	1	1	1	1	1	1	1	1	1	1	1	1	1
Red	Red(0) Dark	0	0	0	0	0	0	0	0	0	0	0	0	0	0	0	0	0	0	0	0	0	0	0	0
	Red(1)	0	0	0	0	0	0	0	1	0	0	0	0	0	0	0	0	0	0	0	0	0	0	0	0
	Red(2)	0	0	0	0	0	0	1	0	0	0	0	0	0	0	0	0	0	0	0	0	0	0	0	0
	:	:	:	:	:	:	:	:	:	:	:	:	:	:	:	:	:	:	:	:	:	:	:	:	
	Red(253)	1	1	1	1	1	1	0	1	0	0	0	0	0	0	0	0	0	0	0	0	0	0	0	0
	Red(254)	1	1	1	1	1	1	1	0	0	0	0	0	0	0	0	0	0	0	0	0	0	0	0	0
	Red(255) Bright	1	1	1	1	1	1	1	1	0	0	0	0	0	0	0	0	0	0	0	0	0	0	0	0
Green	Green(0) Dark	0	0	0	0	0	0	0	0	0	0	0	0	0	0	0	0	0	0	0	0	0	0	0	0
	Green(1)	0	0	0	0	0	0	0	0	0	0	0	0	0	0	1	0	0	0	0	0	0	0	0	
	Green(2)	0	0	0	0	0	0	0	0	0	0	0	0	0	1	0	0	0	0	0	0	0	0	0	
	:	:	:	:	:	:	:	:	:	:	:	:	:	:	:	:	:	:	:	:	:	:	:		
	Green(253)	0	0	0	0	0	0	0	1	1	1	1	1	1	1	0	1	0	0	0	0	0	0	0	
	Green(254)	0	0	0	0	0	0	0	1	1	1	1	1	1	1	1	0	0	0	0	0	0	0	0	
Green(255) Bright	0	0	0	0	0	0	0	1	1	1	1	1	1	1	1	1	0	0	0	0	0	0	0		
Blue	Blue(0) Dark	0	0	0	0	0	0	0	0	0	0	0	0	0	0	0	0	0	0	0	0	0	0	0	0
	Blue(1)	0	0	0	0	0	0	0	0	0	0	0	0	0	0	0	0	0	0	0	0	0	0	0	1
	Blue(2)	0	0	0	0	0	0	0	0	0	0	0	0	0	0	0	0	0	0	0	0	0	0	1	0
	:	:	:	:	:	:	:	:	:	:	:	:	:	:	:	:	:	:	:	:	:	:	:	:	
	Blue(253)	0	0	0	0	0	0	0	0	0	0	0	0	0	0	0	1	1	1	1	1	1	1	0	1
	Blue(254)	0	0	0	0	0	0	0	0	0	0	0	0	0	0	0	1	1	1	1	1	1	1	1	0
Blue(255) Bright	0	0	0	0	0	0	0	0	0	0	0	0	0	0	0	1	1	1	1	1	1	1	1	1	

Product Specification

3-6. Power Sequences

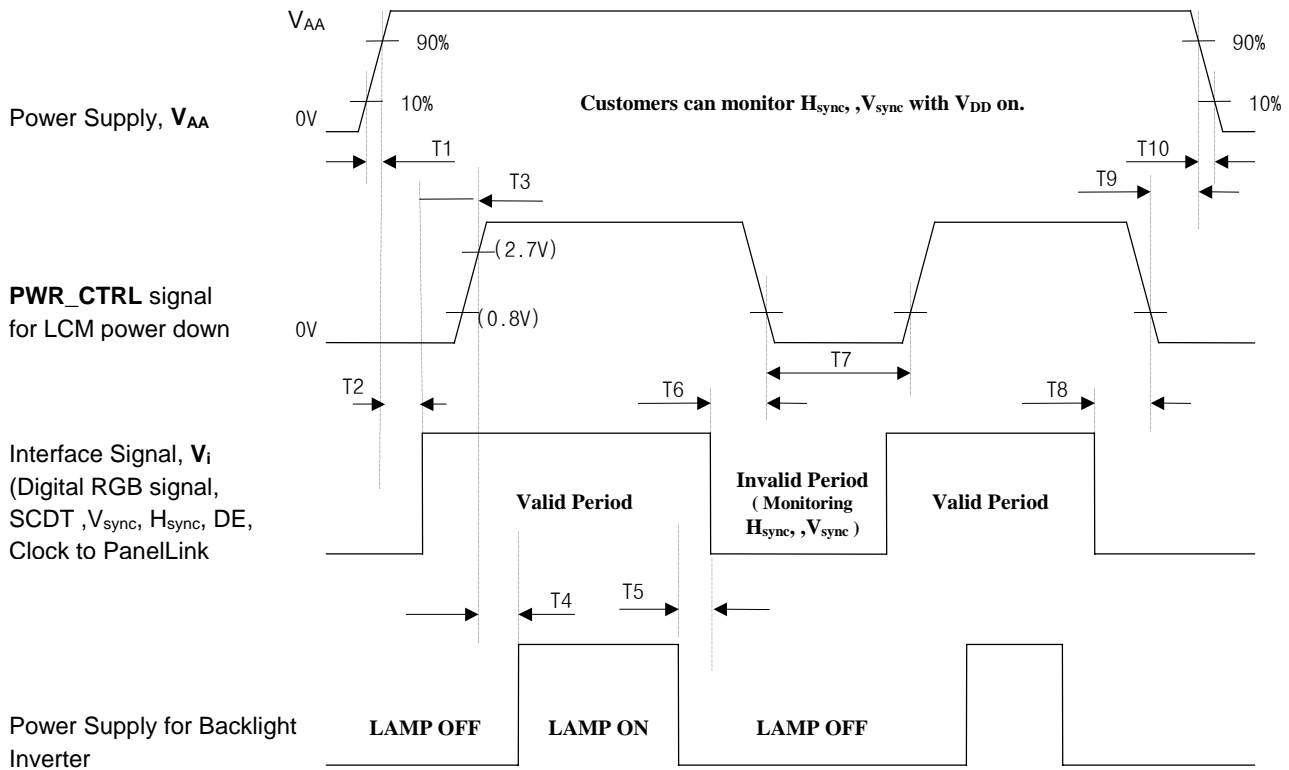

				Unit
	min	typ	max	
T1	-	-	10	ms
T2	-	-	50	ms
T3	-	-	50	ms
T4	200	-	-	ms
T5	200	-	-	ms
T6	-	-	50	ms
T7	400	-	-	ms
T8	-	-	50	ms
T9	-	-	50	ms
T10	-	-	10	ms

- Notes:
1. Please avoid floating state of interface signal at invalid period.
 2. When the interface signal is invalid or no signal, be sure to pull down the power supply, V_{AA} to 0V or to pull down the **PWR_CTRL** signal under 0.8V. Invalid signal with V_{DD} and on state of **PWR_CTRL** signal for a long period of time, causes permanent damage to LCD panel.
 3. BackLight inverter power must be turn on after power supply for LCD and interface signal are valid.
 4. Power supply, V_{AA} shall be start under 0.8V.

Product Specification

4.Optical Specifications

Optical characteristics are determined after the unit has been 'ON' and stable for approximately 30 minutes in a dark environment at 25°C. The values specified are at an approximate distance 50cm from the LCD surface at a viewing angle of Φ and θ equal to 0° and aperture 1 degree. The test equipment is PhotoResearch Prichard SpectroRadiometer Model 1980B-SC or equivalent. The input signal voltage and timing specifications are V_{AA} of 18.0Vdc, and typical values respectively. The input current of lamp is 7.5mA($F_{BL} = 50KHz$) at the ground terminals.

FIG. 1 presents additional information concerning the measurement equipment and method

Table 8 Optical Characteristics

($T_a:25^\circ C$, $V_{AA}:18.0V$, $f_v:60Hz$, $D_{clk}:162MHz$, $I_{BL}:7.5mA$, After 30minutes aging)

Parameter	Symbol	Values			Units	Notes
		Min.	Typ.	Max.		
Contrast Ratio	CR	200	300	-		1
Surface Luminance, white	L_{WH}	200	250	-	cd/m ²	2
Luminance Variation	δ_{WHITE}	-	-	1.8		3
Response Time	T_r	-	30	50	msec	4
Rise Time	T_{rR}	-	15	25		
Decay Time	T_{rD}	-	15	25		
CIE Color Coordinates						
Red	x_R	0.600	0.630	0.660		
	y_R	0.310	0.340	0.370		
Green	x_G	0.270	0.300	0.330		
	y_G	0.560	0.590	0.620		
Blue	x_B	0.120	0.150	0.180		
	y_B	0.080	0.110	0.140		
White	x_W	0.283	0.313	0.343		
	y_W	0.299	0.329	0.359		
Viewing Angle by CR ≥ 10						
x axis, right ($\Phi =0^\circ$)	Θ_r	80	-	-	degree, °	5
x axis, left($\Phi =180^\circ$)	Θ_l	80	-	-		
y axis, up($\Phi =90^\circ$)	Θ_u	80	-	-		
y axis, down ($\Phi =270^\circ$)	Θ_d	80	-	-		
Gray Scale		--	-	-		6

Product Specification

5.Mechanical Characteristics

The chart below provides general mechanical characteristics for the model LM201U1 LCD. Please refer to next page regarding the detailed mechanical drawing of the LCD module.

Table 9 Mechanical Specifications

Parameter	Value	Symbol
Outside dimension Width Height Thickness	467.8 (typ) 361.0 (typ) 32.0 (max)	mm
Bezel area Width Height	413 311	mm
Active area Width Height	408.0 306.0	mm
Weight	4100(typ) 4300(max)	gram
Front surface of LCD	Hard coating 3H. Anti-glare treatment of the front polarizer	-

Product Specification

6. Reliability

No	Test ITEM	Conditions
1	High temperature operating test	50 °C , 240 hour
2	High temperature storage test	60 °C , 240 hour
3	Low temperature operating test	5 °C , 240 hours
4	Thermal Shock Test (non-operating)	-20 °C/30minutes, 60 °C/30minutes, 50cycle
5	Altitude (non-operating)	Storage : 40,000ft
6	Vibration test (non-operating)	Waveform : Random Vibration level : 1.0 G RMS Bandwidth : 10 ~500Hz Duration : X, Y, Z, 10 min one time each direction
7	Shock test (non-operating)	Shock level : 100G Waveform: half sine wave, 2ms Direction : ±X, ±Y, ±Z one time each direction

<Result Evaluation Criteria>

There should be no changes, which might affect the practical display function when the display quality test is conducted under normal operating condition.

7. International Standards

7-1. Safety

- a) UL 1950 Third Edition, Underwriters Laboratories, Inc. Jan. 28, 1995.
Standard for Safety of Information Technology Equipment Including Electrical Business Equipment.
- b) CAN/CSA C22.2 No. 950-95 Third Edition, Canadian Standards Association, Jan. 28, 1995.
Standard for Safety of Information Technology Equipment Including Electrical Business Equipment.
- c) EN 60950 : 1992 + A1 : 1993 + A2 : 1993 + A3 : 1995 + A4 : 1997 + A11 : 1997
IEC 950 : 1991 + A1 : 1992 + A2 : 1993 + A3 : 1995 + A4 : 1996
European Committee for Electrotechnical Standardization (CENELEC)
EUROPEAN STANDARD for Safety of Information Technology Equipment Including Electrical Business Equipment.

7-2. EMC

- a) ANSI C63.4 "Methods of Measurement of Radio-Noise Emissions from Low-Voltage Electrical and Electronic Equipment in the Range of 9kHz to 40GHz." American National Standards Institute(ANSI),1992.
- b) C.I.S.P.R "Limits and Methods of Measurement of Radio Interference Characteristics of Information Technology Equipment." International Special Committee on Radio Interference
- c) EN 55022 "Limits and Methods of Measurement of Radio Interference Characteristics of Information Technology Equipment." European Committee for Electrotechnical Standardization (CENELEC),1988

Product Specification

8. Packing

8-1. Designation of Lot Mark

a) Lot Mark

A	B	C	D	E	F	G	H	I	J	K	L	M
---	---	---	---	---	---	---	---	---	---	---	---	---

A, B, C : SIZE
 D : YEAR
 E : MONTH
 F, G : PANEL CODE
 H : ASSEMBLY CODE
 I, J, K, L, M : SERIAL NO.

Note : 1. YEAR

YEAR	97	98	99	2000	2001	2002	2003	2004	2005	2006	2007
Mark	7	8	9	0	1	2	3	4	5	6	7

2. MONTH

MONTH	Jan.	Feb.	Mar.	Apr.	May.	Jun.	Jul.	Aug.	Sep.	Oct.	Nov.	Dec.
Mark	1	2	3	4	5	6	7	8	9	A	B	C

b) Location of Lot Mark

Serial NO. is printed on the label. The label is attached to the backside of the LCD module.
 This is subject to change without notice.

8-2. Packing Form

a) Package quantity in one box : 3 pcs

b) Box Size : 470 mm × 253 mm × 573 mm

9. Precautions

Please pay attention to the followings when you use this TFT LCD module.

9.1 Mounting Precautions

- (1) You must mount a module using holes arranged in four corners or four sides.
- (2) You should consider the mounting structure so that uneven force (ex. twisted stress) is not applied to the module. And the case on which a module is mounted should have sufficient strength so that external force is not transmitted directly to the module.
- (3) Please attach a transparent protective plate to the surface in order to protect the polarizer. Transparent protective plate should have sufficient strength in order to resist external force.
- (4) You should adopt radiation structure to satisfy the temperature specification.
- (5) Acetic acid type and chlorine type materials for the cover case are not desirable because the former generates corrosive gas of attacking the polarizer at high temperature and the latter causes circuit break by electro-chemical reaction.
- (6) Do not touch, push or rub the exposed polarizers with glass, tweezers or anything harder than HB pencil lead. And please do not rub with dust clothes with chemical treatment. Do not touch the surface of polarizer for bare hand or greasy cloth. (Some cosmetics are detrimental to the polarizer.)
- (7) When the surface becomes dusty, please wipe gently with absorbent cotton or other soft materials like chamois soaked with petroleum benzene. Normal-hexane is recommended for cleaning the adhesives used to attach front / rear polarizers. Do not use acetone, toluen and alcohol because they cause chemical damage to the polarizer.
- (8) Wipe off saliva or water drops as soon as possible. Their long time contact with polarizer causes deformations and color fading.
- (9) Do not open the case because inside circuits do not have sufficient strength.

9.2 Operating Precautions

- (1) The spike noise causes the mis-operation of circuits. It should be lower than following voltage :
 $V = \pm 200\text{mV}$ (Over and under shoot voltage).
- (2) Response time depends on the temperature. (In lower temperature, it becomes longer.)
- (3) Brightness depends on the temperature. (In lower temperature, it becomes lower.)
And in lower temperature, response time (required time that brightness is stable after turned on) becomes longer.
- (4) Be careful for condensation at sudden temperature change. Condensation makes damage to polarizer or electrical contacted parts. And after fading condensation, smear or spot will occur.
- (5) When fixed patterns are displayed for a long time, remnant image is likely to occur.
- (6) A module has high frequency circuit. If you need to shield the electromagnetic noise, please do in yours. When a Back-light unit is operating, it sounds. If you need to shield the noise, please do in yours.

9.3 Electrostatic Discharge Control

Since a module is composed of electronic circuits, it is not strong to electrostatic discharge. Make certain that treatment persons are connected to ground through wrist band etc . And don't touch interface pin directly.

9.4 Precautions for strong light exposure

Strong light exposure causes degradation of polarizer and color filter.

9.5 Storage

When storing modules as spares for a long time, the following precautions are necessary.

- (1) Store them in a dark place. Do not expose the module to sunlight or fluorescent light. Keep the temperature between 5°C and 35°C at normal humidity.
- (2) The polarizer surface should not come in contact with any other object.
It is recommended that they be stored in the container in which they were shipped.

9.6 Handling Precautions for protection film

- (1) When the protection film is peeled off, static electricity is generated between the film and polarizer. This should be peeled off slowly and carefully by people who are electrically grounded and with well ion- blown equipment or in such a condition, etc..
- (2) The protection film is attached to the polarizer with a small amount of glue. If some stress is applied to rub the protection film against the polarizer during the time you peel off the film, the glue is apt to remain on the polarizer. Please carefully peel off the protection film without rubbing it against the polarizer.
- (3) When the module with protection film attached is stored for a long time, sometimes there remains a very small amount of glue still on the polarizer after the protection film is peeled off.
- (4) You can remove the glue easily. When the glue remains on the polarizer surface or its vestige is recognized, please wipe them off with absorbent cotton waste or other soft material like chamois soaked with normal-hexane.

Product Specification
APPENDIX 1 : Required Signal Assignment for Sil160 TMD5 Receiver

Graphics Controller		PanelLink		Flat Panel Controller	
24-bits	18-bits	Sil160	Sil161	18-bits	24-bits
B0 - 0		DIE0	QE0		B0 - 0
B1 - 0		DIE1	QE1		B1 - 0
B2 - 0	B0 - 0	DIE2	QE2	B0 - 0	B2 - 0
B3 - 0	B1 - 0	DIE3	QE3	B1 - 0	B3 - 0
B4 - 0	B2 - 0	DIE4	QE4	B2 - 0	B4 - 0
B5 - 0	B3 - 0	DIE5	QE5	B3 - 0	B5 - 0
B6 - 0	B4 - 0	DIE6	QE6	B4 - 0	B6 - 0
B7 - 0	B5 - 0	DIE7	QE7	B5 - 0	B7 - 0
G0 - 0		DIE8	QE8		G0 - 0
G1 - 0		DIE9	QE9		G1 - 0
G2 - 0	G0 - 0	DIE10	QE10	G0 - 0	G2 - 0
G3 - 0	G1 - 0	DIE11	QE11	G1 - 0	G3 - 0
G4 - 0	G2 - 0	DIE12	QE12	G2 - 0	G4 - 0
G5 - 0	G3 - 0	DIE13	QE13	G3 - 0	G5 - 0
G6 - 0	G4 - 0	DIE14	QE14	G4 - 0	G6 - 0
G7 - 0	G5 - 0	DIE15	QE15	G5 - 0	G7 - 0
R0 - 0		DIE16	QE16		R0 - 0
R1 - 0		DIE17	QE17		R1 - 0
R2 - 0	R0 - 0	DIE18	QE18	R0 - 0	R2 - 0
R3 - 0	R1 - 0	DIE19	QE19	R1 - 0	R3 - 0
R4 - 0	R2 - 0	DIE20	QE20	R2 - 0	R4 - 0
R5 - 0	R3 - 0	DIE21	QE21	R3 - 0	R5 - 0
R6 - 0	R4 - 0	DIE22	QE22	R4 - 0	R6 - 0
R7 - 0	R5 - 0	DIE23	QE23	R5 - 0	R7 - 0
B0 - 1		DIO0	QO0		B0 - 1
B1 - 1		DIO1	QO1		B1 - 1
B2 - 1	B0 - 1	DIO2	QO2	B0 - 1	B2 - 1
B3 - 1	B1 - 1	DIO3	QO3	B1 - 1	B3 - 1
B4 - 1	B2 - 1	DIO4	QO4	B2 - 1	B4 - 1
B5 - 1	B3 - 1	DIO5	QO5	B3 - 1	B5 - 1
B6 - 1	B4 - 1	DIO6	QO6	B4 - 1	B6 - 1
B7 - 1	B5 - 1	DIO7	QO7	B5 - 1	B7 - 1
G0 - 1		DIO8	QO8		G0 - 1
G1 - 1		DIO9	QO9		G1 - 1
G2 - 1	G0 - 1	DIO10	QO10	G0 - 1	G2 - 1
G3 - 1	G1 - 1	DIO11	QO11	G1 - 1	G3 - 1
G4 - 1	G2 - 1	DIO12	QO12	G2 - 1	G4 - 1
G5 - 1	G3 - 1	DIO13	QO13	G3 - 1	G5 - 1
G6 - 1	G4 - 1	DIO14	QO14	G4 - 1	G6 - 1
G7 - 1	G5 - 1	DIO15	QO15	G5 - 1	G7 - 1
R0 - 1		DIO16	QO16		R0 - 1
R1 - 1		DIO17	QO17		R1 - 1
R2 - 1	R0 - 1	DIO18	QO18	R0 - 1	R2 - 1
R3 - 1	R1 - 1	DIO19	QO19	R1 - 1	R3 - 1
R4 - 1	R2 - 1	DIO20	QO20	R2 - 1	R4 - 1
R5 - 1	R3 - 1	DIO21	QO21	R3 - 1	R5 - 1
R6 - 1	R4 - 1	DIO22	QO22	R4 - 1	R6 - 1
R7 - 1	R5 - 1	DIO23	QO23	R5 - 1	R7 - 1
Shift CLK	Shift CLK	IDCK	ODCK	Shift CLK	Shift CLK
VSYNC	VSYNC	VSYNC	VSYNC	VSYNC	VSYNC
HSYNC	HSYNC	HSYNC	HSYNC	HSYNC	HSYNC
DE	DE	DE	DE	DE	DE