



() Preliminary Specification
(V) Final Specification

Module	24.0" WUXGA Color TFT-LCD
Model Name	M240UW01 V2

Customer	Date
_____	_____
Approved by	
_____	_____
<p>Note: This Specification is subject to change without notice.</p>	

Prepared by	Date
<u>Louis Jung</u>	<u>Apr. 27, 2007</u>
Approved by	
<u>CC Chiu</u>	<u>Apr. 27, 2007</u>
<p>Desktop Display Business Group / AU Optronics corporation</p>	

Contents

1.0 Handling Precautions	5
2.0 General Description	6
2.1 Display Characteristics	6
2.2 Optical Characteristics	7
3.0 Functional Block Diagram	10
4.0 Absolute Maximum Ratings.....	11
4.1 TFT LCD Module	11
4.2 Backlight Unit	11
4.3 Absolute Ratings of Environment.....	11
5.0 Electrical characteristics	12
5.1 TFT LCD Module	12
5.1.1 Power Specification.....	12
5.1.2 LVDS Signal Electrical Characteristics	13
5.1.3 I2C Signal Electrical Characteristics	14
Note	15
6.0 Signal Characteristic	19
6.1 Pixel Format Image	19
6.2 The input data format.....	19
6.3 Signal Description.....	20
6.4 Timing Characteristics.....	21
6.5 Timing diagram.....	22
6.6 Power ON/OFF Sequence	23
7.0 Connector & Pin Assignment.....	24
7.1 TFT LCD Module	24
7.1.1 LVDS Signal Connector and Pin Assignment	24
7.1.2 I2C Signal connector and Pin Assignment	25
7.2 Backlight Unit	26
7.2.1 Signal for Lamp connector	26
8.0 Reliability Test	27
9.0 Shipping Label	28
10.0 Mechanical Characteristics.....	29

Record of Revision

Version and Date	Page	Old description	New Description	Remark																																																																								
0.1 2006/7/24	All	First Edition for Customer	-																																																																									
0.2 2006/8/29	5,6	Response Time 12ms(Typ., on/off); TBD (Typ., GTG)	Response Time 16ms(Typ., on/off); 6ms (Typ., GTG)	Modified																																																																								
	6	Power Consumption TBD watt	Power Consumption 76.3 watt																																																																									
	12	LCD Inrush current TBD A	LCD Inrush current 5 A																																																																									
0.3 2006/11/1	18	CCFL Life time 50,000(typ);40,000(min)	CCFL Life time 50,000(min)	Modified																																																																								
	26	Lamp connector type: Manufacturer:JST Type part number: BHR-04VS-1	Change to Locking Type, Manufacturer:CVILUX or Compatible Type part number: CP0404SL000	Modified																																																																								
	12	The duration of rush current is about 2ms and rising time of power input is 1ms(min.).	The duration of rising time of power input is 470us.	Modified																																																																								
	5,18	2.1 Power consumption = 74 watt 5.2 Backlight Unit <table border="1" style="width:100%; border-collapse: collapse;"> <thead> <tr> <th>Parameter</th> <th>Min.</th> <th>Typ.</th> <th>Unit</th> </tr> </thead> <tbody> <tr> <td>CCFL Ignition Voltage(VICFL, Ta= 0°C)</td> <td>2850</td> <td>-</td> <td>[Volt] rms</td> </tr> <tr> <td>CCFL Ignition Voltage(VICF, Ta= 25°C)</td> <td>2280</td> <td>-</td> <td>[Volt] rms</td> </tr> <tr> <td>CCFL Operation Voltage (VCFL)</td> <td>-</td> <td>1800 (@ 6mA)</td> <td>[Volt] rms</td> </tr> <tr> <td>CCFL Power Consumption(PCFL)</td> <td>-</td> <td>64.8</td> <td>[Watt]</td> </tr> </tbody> </table>	Parameter	Min.	Typ.	Unit	CCFL Ignition Voltage(VICFL, Ta= 0°C)	2850	-	[Volt] rms	CCFL Ignition Voltage(VICF, Ta= 25°C)	2280	-	[Volt] rms	CCFL Operation Voltage (VCFL)	-	1800 (@ 6mA)	[Volt] rms	CCFL Power Consumption(PCFL)	-	64.8	[Watt]	2.1 Power consumption = 70 watt 5.2 Backlight Unit <table border="1" style="width:100%; border-collapse: collapse;"> <thead> <tr> <th>Parameter</th> <th>Min.</th> <th>Typ.</th> <th>Unit</th> </tr> </thead> <tbody> <tr> <td>CCFL Ignition Voltage(VICFL, Ta= 0°C)</td> <td>2720</td> <td>-</td> <td>[Volt] rms</td> </tr> <tr> <td>CCFL Ignition Voltage(VICF, Ta= 25°C)</td> <td>2270</td> <td>-</td> <td>[Volt] rms</td> </tr> <tr> <td>CCFL Operation Voltage (VCFL)</td> <td>-</td> <td>1690 (@ 6mA)</td> <td>[Volt] rms</td> </tr> <tr> <td>CCFL Power Consumption(PCFL)</td> <td>-</td> <td>60.8</td> <td>[Watt]</td> </tr> </tbody> </table>	Parameter	Min.	Typ.	Unit	CCFL Ignition Voltage(VICFL, Ta= 0°C)	2720	-	[Volt] rms	CCFL Ignition Voltage(VICF, Ta= 25°C)	2270	-	[Volt] rms	CCFL Operation Voltage (VCFL)	-	1690 (@ 6mA)	[Volt] rms	CCFL Power Consumption(PCFL)	-	60.8	[Watt]	Modified																																
Parameter	Min.	Typ.	Unit																																																																									
CCFL Ignition Voltage(VICFL, Ta= 0°C)	2850	-	[Volt] rms																																																																									
CCFL Ignition Voltage(VICF, Ta= 25°C)	2280	-	[Volt] rms																																																																									
CCFL Operation Voltage (VCFL)	-	1800 (@ 6mA)	[Volt] rms																																																																									
CCFL Power Consumption(PCFL)	-	64.8	[Watt]																																																																									
Parameter	Min.	Typ.	Unit																																																																									
CCFL Ignition Voltage(VICFL, Ta= 0°C)	2720	-	[Volt] rms																																																																									
CCFL Ignition Voltage(VICF, Ta= 25°C)	2270	-	[Volt] rms																																																																									
CCFL Operation Voltage (VCFL)	-	1690 (@ 6mA)	[Volt] rms																																																																									
CCFL Power Consumption(PCFL)	-	60.8	[Watt]																																																																									
	23	6.6 Power ON/OFF Sequence T1=0.3ms (min)	6.6 Power ON/OFF Sequence T1=0.5ms (min)	Modified																																																																								
	5	2.2 Weight (Grams) 3250 (Max)	2.2 Weight (Grams) 3250 (Typ.)	Modified																																																																								
0.4 2007/2/27	6	2.1 Power consumption = 70 watt	2.1 Power consumption Normal=70 W (Typ.) SPD(30%) = 75 W	Modified																																																																								
	7	2.2 Optical Characteristics Delete Gray to Gray response time <table border="1" style="width:100%; border-collapse: collapse;"> <thead> <tr> <th>Item</th> <th>Unit</th> <th>Conditions</th> <th>Min.</th> <th>Typ.</th> <th>Max.</th> </tr> </thead> <tbody> <tr> <td rowspan="4">Response Time</td> <td>[msec]</td> <td>Raising Time</td> <td>-</td> <td>10</td> <td>-</td> </tr> <tr> <td>[msec]</td> <td>Falling Time</td> <td>-</td> <td>6</td> <td>-</td> </tr> <tr> <td>[msec]</td> <td>Raising + Falling</td> <td>-</td> <td>16</td> <td>20</td> </tr> <tr> <td>[msec]</td> <td>Gray to Gray</td> <td>-</td> <td>-</td> <td>-</td> </tr> </tbody> </table>	Item	Unit	Conditions	Min.	Typ.	Max.	Response Time	[msec]	Raising Time	-	10	-	[msec]	Falling Time	-	6	-	[msec]	Raising + Falling	-	16	20	[msec]	Gray to Gray	-	-	-	2.2 Optical Characteristics <table border="1" style="width:100%; border-collapse: collapse;"> <thead> <tr> <th>Item</th> <th>Unit</th> <th>Conditions</th> <th>Min.</th> <th>Typ.</th> <th>Max.</th> <th>Note</th> </tr> </thead> <tbody> <tr> <td rowspan="3">Response Time</td> <td>[msec]</td> <td>Raising Time</td> <td>-</td> <td>10</td> <td>-</td> <td>Note 1</td> </tr> <tr> <td>[msec]</td> <td>Falling Time</td> <td>-</td> <td>6</td> <td>-</td> <td>Note 1</td> </tr> <tr> <td>[msec]</td> <td>Raising + Falling</td> <td>-</td> <td>16</td> <td>20</td> <td>Note 1</td> </tr> </tbody> </table>	Item	Unit	Conditions	Min.	Typ.	Max.	Note	Response Time	[msec]	Raising Time	-	10	-	Note 1	[msec]	Falling Time	-	6	-	Note 1	[msec]	Raising + Falling	-	16	20	Note 1	Modified																			
Item	Unit	Conditions	Min.	Typ.	Max.																																																																							
Response Time	[msec]	Raising Time	-	10	-																																																																							
	[msec]	Falling Time	-	6	-																																																																							
	[msec]	Raising + Falling	-	16	20																																																																							
	[msec]	Gray to Gray	-	-	-																																																																							
Item	Unit	Conditions	Min.	Typ.	Max.	Note																																																																						
Response Time	[msec]	Raising Time	-	10	-	Note 1																																																																						
	[msec]	Falling Time	-	6	-	Note 1																																																																						
	[msec]	Raising + Falling	-	16	20	Note 1																																																																						
	8	Note 2 Over-Drive and Response time Note 3 Luminance uniformity of these 9 points is defined as below. Note 4:Crosstalk is defined as below Note 5: Test pattern:Subchecker Pattern	Delete the original Note 2 Note 2 Luminance uniformity of these 9 points is defined as below. Note 3:Crosstalk is defined as below Note 4: Test pattern:Subchecker Pattern	Modified																																																																								
	12	5.1.1 Power Specification <table border="1" style="width:100%; border-collapse: collapse;"> <thead> <tr> <th>Symbol</th> <th>Parameter</th> <th>Min</th> <th>Typ</th> <th>Max</th> <th>Units</th> </tr> </thead> <tbody> <tr> <td>VDD</td> <td>Logic/LCD Drive Voltage</td> <td>4.5</td> <td>5.0</td> <td>5.5</td> <td>[Volt]</td> </tr> <tr> <td>IDD</td> <td>VDD current</td> <td>-</td> <td>1.8</td> <td>2.2</td> <td>[A]</td> </tr> <tr> <td>Inrush</td> <td>LCD Inrush Current</td> <td>-</td> <td>-</td> <td>5</td> <td>[A]</td> </tr> <tr> <td>PCD</td> <td>VDD Power</td> <td>-</td> <td>9</td> <td>11</td> <td>[Watt]</td> </tr> </tbody> </table>	Symbol	Parameter	Min	Typ	Max	Units	VDD	Logic/LCD Drive Voltage	4.5	5.0	5.5	[Volt]	IDD	VDD current	-	1.8	2.2	[A]	Inrush	LCD Inrush Current	-	-	5	[A]	PCD	VDD Power	-	9	11	[Watt]	5.1.1 Power Specification <table border="1" style="width:100%; border-collapse: collapse;"> <thead> <tr> <th>Symbol</th> <th>Parameter</th> <th>Min</th> <th>Typ</th> <th>Max</th> <th>Units</th> </tr> </thead> <tbody> <tr> <td>VDD</td> <td>Logic/LCD Drive Voltage</td> <td>4.5</td> <td>5.0</td> <td>5.5</td> <td>[Volt]</td> </tr> <tr> <td>IDD (Normal.)</td> <td>VDD current</td> <td>-</td> <td>1.8</td> <td>2.2</td> <td>[A]</td> </tr> <tr> <td>IDD (SPD 30%)</td> <td>VDD current</td> <td>-</td> <td>2.5</td> <td>3</td> <td>[A]</td> </tr> <tr> <td>Inrush</td> <td>LCD Inrush Current</td> <td>-</td> <td>-</td> <td>5</td> <td>[A]</td> </tr> <tr> <td>PCD (Normal.)</td> <td>VDD Power</td> <td>-</td> <td>9</td> <td>11</td> <td>[Watt]</td> </tr> <tr> <td>PCD (SPD 30%)</td> <td>VDD Power</td> <td>-</td> <td>12.5</td> <td>15</td> <td>[Watt]</td> </tr> </tbody> </table>	Symbol	Parameter	Min	Typ	Max	Units	VDD	Logic/LCD Drive Voltage	4.5	5.0	5.5	[Volt]	IDD (Normal.)	VDD current	-	1.8	2.2	[A]	IDD (SPD 30%)	VDD current	-	2.5	3	[A]	Inrush	LCD Inrush Current	-	-	5	[A]	PCD (Normal.)	VDD Power	-	9	11	[Watt]	PCD (SPD 30%)	VDD Power	-	12.5	15	[Watt]	Modified
Symbol	Parameter	Min	Typ	Max	Units																																																																							
VDD	Logic/LCD Drive Voltage	4.5	5.0	5.5	[Volt]																																																																							
IDD	VDD current	-	1.8	2.2	[A]																																																																							
Inrush	LCD Inrush Current	-	-	5	[A]																																																																							
PCD	VDD Power	-	9	11	[Watt]																																																																							
Symbol	Parameter	Min	Typ	Max	Units																																																																							
VDD	Logic/LCD Drive Voltage	4.5	5.0	5.5	[Volt]																																																																							
IDD (Normal.)	VDD current	-	1.8	2.2	[A]																																																																							
IDD (SPD 30%)	VDD current	-	2.5	3	[A]																																																																							
Inrush	LCD Inrush Current	-	-	5	[A]																																																																							
PCD (Normal.)	VDD Power	-	9	11	[Watt]																																																																							
PCD (SPD 30%)	VDD Power	-	12.5	15	[Watt]																																																																							

0.5	2007/3/12	6	2.1 Power consumption Normal=70 W (Typ.) SPD(30%) = 75 W (without inverter)	2.1 Power consumption Normal=70 W (Typ.) SPD = 75 W	Modified																												
		6	Contrast ratio: 800(Typ)	Contrast ratio: 1000(Typ)	Modified																												
		7	Contrast ratio: Min:TBD	Contrast ratio: Min:800	Modified																												
		12	5.1.1 Power Specification <table border="1"> <thead> <tr> <th>Symbol</th> <th>Parameter</th> <th>Min</th> <th>Typ</th> <th>Max</th> <th>Units</th> <th>Condition</th> </tr> </thead> <tbody> <tr> <td>VDD</td> <td>LogicLCD Drive Voltage</td> <td>4.5</td> <td>5.0</td> <td>5.5</td> <td>[Volt]</td> <td>±10%</td> </tr> </tbody> </table>	Symbol	Parameter	Min	Typ	Max	Units	Condition	VDD	LogicLCD Drive Voltage	4.5	5.0	5.5	[Volt]	±10%	5.1.1 Power Specification <table border="1"> <thead> <tr> <th>Symbol</th> <th>Parameter</th> <th>Min</th> <th>Typ</th> <th>Max</th> <th>Units</th> <th>Condition</th> </tr> </thead> <tbody> <tr> <td>VDD</td> <td>LogicLCD Drive Voltage</td> <td>4.75</td> <td>5.0</td> <td>5.25</td> <td>[Volt]</td> <td>±5%</td> </tr> </tbody> </table>	Symbol	Parameter	Min	Typ	Max	Units	Condition	VDD	LogicLCD Drive Voltage	4.75	5.0	5.25	[Volt]	±5%	Modified
Symbol	Parameter	Min	Typ	Max	Units	Condition																											
VDD	LogicLCD Drive Voltage	4.5	5.0	5.5	[Volt]	±10%																											
Symbol	Parameter	Min	Typ	Max	Units	Condition																											
VDD	LogicLCD Drive Voltage	4.75	5.0	5.25	[Volt]	±5%																											
		16	1. External i2c master write ASIC 1. Check nBUSY=1? 2. IF nBUSY=1, Set TSEN=L 3. Wait 500us 4. Set FTM=H 5. Start to Write ASIC	<pre> graph TD A[Check nBUSY] --> B{If nBUSY=1} B -- YES --> C[Set TSEN=L] B -- NO --> A C --> D[Wait 500us] D --> E[Set FTM=H] E --> F[Start to Write ASIC] </pre>	Modified																												
		16	2. External i2c master read ASIC 1. Check nBUSY=1? 2. IF nBUSY=1, Set TSEN=L 3. Wait 500us 4. Set FTM=H 5. Start to Read ASIC	<pre> graph TD A[Check nBUSY] --> B{If nBUSY=1} B -- YES --> C[Set TSEN=L] B -- NO --> A C --> D[Wait 500us] D --> E[Set FTM=H] E --> F[Start to Read ASIC] </pre>	Modified																												
		29			Modified																												
		31			Modified																												
1.1		7	Contrast ratio min:800	Contrast ratio min:600	Modified																												

1.0 Handling Precautions

- 1) Since front polarizer is easily damaged, pay attention not to scratch it.
- 2) Be sure to turn off power supply when inserting or disconnecting from input connector.
- 3) Wipe off water drop immediately. Long contact with water may cause discoloration or spots.
- 4) When the panel surface is soiled, wipe it with absorbent cotton or other soft cloth.
- 5) Since the panel is made of glass, it may break or crack if dropped or bumped on hard surface.
- 6) Since CMOS LSI is used in this module, take care of static electricity and insure human earth when handling.
- 7) Do not open or modify the Module Assembly.
- 8) Do not press the reflector sheet at the back of the module to any directions.
- 9) In case if a Module has to be put back into the packing container slot after once it was taken out from the container, do not press the center of the CCFL reflector edge. Instead, press at the far ends of the CCFL Reflector edge softly. Otherwise the TFT Module may be damaged.
- 10) At the insertion or removal of the Signal Interface Connector, be sure not to rotate nor tilt the Interface Connector of the TFT Module.
- 11) After installation of the TFT Module into an enclosure, do not twist nor bend the TFT Module even momentary. At designing the enclosure, it should be taken into consideration that no bending/twisting forces are applied to the TFT Module from outside. Otherwise the TFT Module may be damaged.
- 12) Cold cathode fluorescent lamp in LCD contains a small amount of mercury. Please follow local ordinances or regulations for disposal.
- 13) Small amount of materials having no flammability grade is used in the LCD module. The LCD module should be supplied by power complied with requirements of Limited Power Source (IEC60950 or UL1950), or be applied exemption.
- 14) The LCD module is designed so that the CCFL in it is supplied by Limited Current Circuit (IEC60950 or UL1950). Do not connect the CCFL in Hazardous Voltage Circuit.

2.0 General Description

This specification applies to the 24.0 inch Color a-Si TFT-LCD Module M240UW01.

The display supports the WUXGA (1920(H) x 1200(V)) screen format and 16.7M colors (RGB 8-bits data).

All input signals are 2 channel LVDS interface compatible.

This module doesn't contain an inverter board for backlight.

2.1 Display Characteristics

The following items are characteristics summary on the table under 25 °C condition:

ITEMS	Unit	SPECIFICATIONS
Screen Diagonal	[mm]	611.32(24")
Active Area	[mm]	518.4 (H) x 324 (V)
Pixels H x V		1920(x3) x 1200
Pixel Pitch	[mm]	0.270 (per one triad) x 0.270
Pixel Arrangement		R.G.B. Vertical Stripe
Display Mode		Normally Black
White Luminance (Center)	[cd/m ²]	500 cd/m ² @ I _L =6mA (Typ.)
Contrast Ratio		1000 (Typ.)
Optical Response Time	[msec]	16ms (Typ., on/off)
Nominal Input Voltage VDD	[Volt]	+5.0 V
Power Consumption (VDD line + CCFL line)	[Watt]	Normal : 70 W (Typ.) SPD : 75W
Weight	[Grams]	2710 (Typ.)
Physical Size	[mm]	546.4(W) x 352(H) x 35.8(D) (Typ.)
Electrical Interface		Even/Odd R/G/B data, clock LVDS
Support Color		16.7M colors (RGB 8-bit data)
Surface Treatment		Anti-Glare, 3H
Temperature Range Operating	[°C]	0 to +50
Storage (Shipping)	[°C]	-20 to +60
RoHS Compliance		RoHS Compliance
SPD function		I2C control

2.2 Optical Characteristics

The optical characteristics are measured under stable conditions at 25°C:

Item	Unit	Conditions	Min.	Typ.	Max.	Note
Viewing Angle	[degree]	Horizontal (Right) CR = 10 (Left)	75	89	-	
	[degree]		75	89	-	
	[degree]	Vertical (Up) CR = 10 (Down)	75	89	-	
	[degree]		75	89	-	
Contrast ratio		Normal Direction	600	1000	-	
Response Time	[msec]	Raising Time	-	10	-	Note 1
	[msec]	Falling Time	-	6	-	Note 1
	[msec]	Raising + Falling	-	16	20	Note 1
Color / Chromaticity Coordinates (CIE)		Red x	0.623	0.653	0.683	
		Red y	0.307	0.337	0.367	
		Green x	0.265	0.295	0.325	
		Green y	0.577	0.607	0.637	
		Blue x	0.114	0.144	0.174	
		Blue y	0.045	0.075	0.105	
Color Coordinates (CIE) White		White x	0.283	0.313	0.343	
		White y	0.299	0.329	0.359	
Central Luminance (I _L =6mA)	[cd/m ²]		400	500	-	
Luminance Uniformity	[%]		75	80	-	Note 2
Crosstalk (in60Hz)	[%]				1.5	Note 3
Flicker	dB				-20	Note 4

Equipment Pattern Generator, Power Supply, Digital Voltmeter, Luminance meter (PR 880, BM-5A ,

BM 7 ,CS-1000, & EZContrast*)

Aperture 1° with 100cm VD or 2° with 50cm viewing distance

Test Point Center (VESA point 9)

Environment < 1 lux

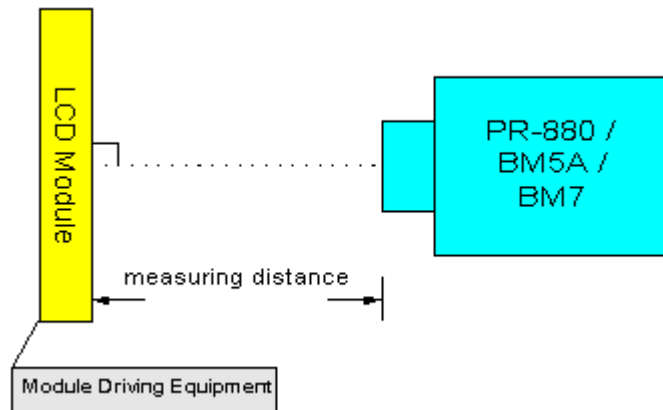

*' EZ Contrast is different measurement tool with very close viewing distance.

Note 1: Definition of Response time

The output signals of photodetector are measured when the input signals are changed from "Black" to "White" (rising time), and from "White" to "Black" (falling time), respectively. The response time is interval between the 10% and 90% of amplitudes.

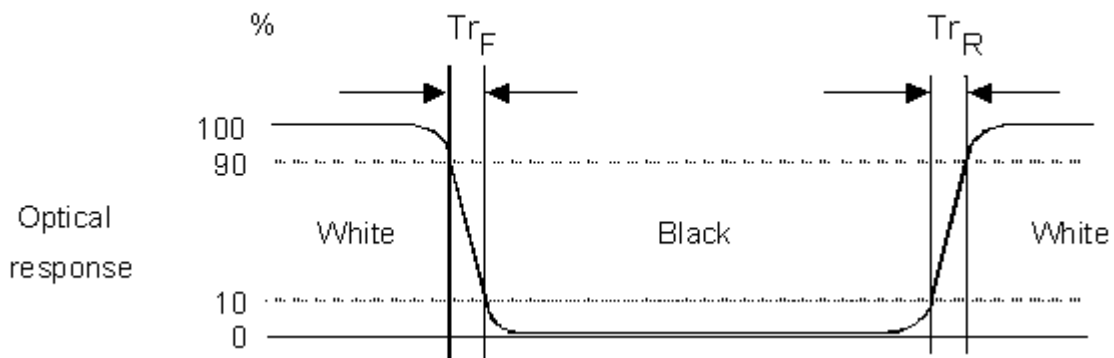

Note 2: Luminance uniformity of these 9 points is defined as below

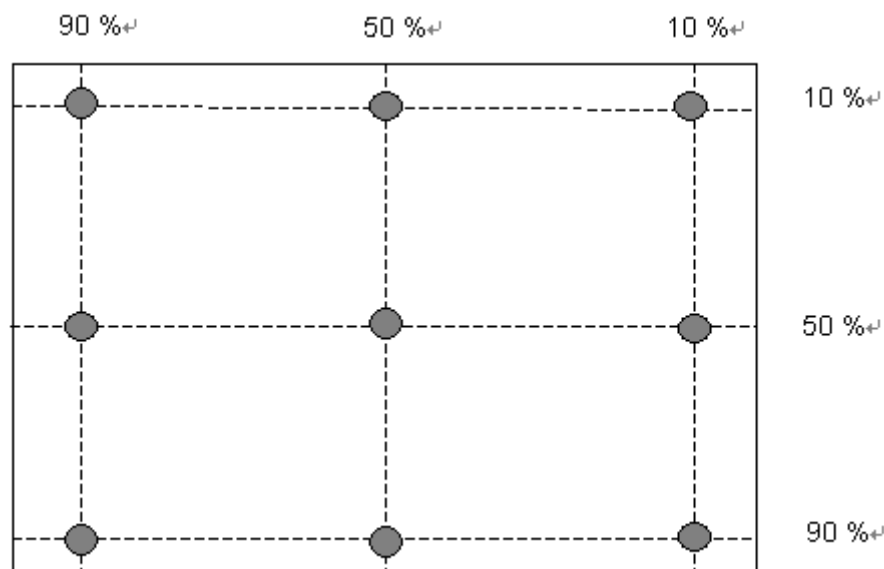

$$\text{Uniformity} = \frac{\text{Minimum Luminance in 9 points (1-9)}}{\text{Maximum Luminance in 9 Points (1-9)}}$$

Note 3: Crosstalk is defined as below :

$$CT = | YB - YA | / YA \times 100 (\%)$$

Where

YA = Luminance of measured location without gray level 0 pattern (cd/m²)

YB = Luminance of measured location with gray level 0 pattern (cd/m²)

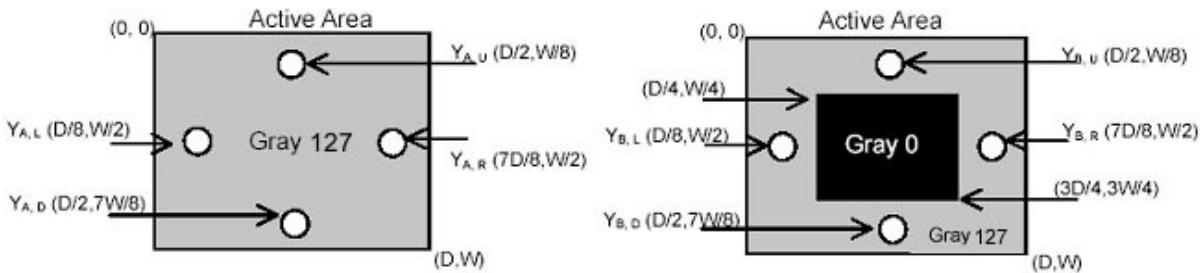

Note 4: Test Patern: Subchecker Pattern

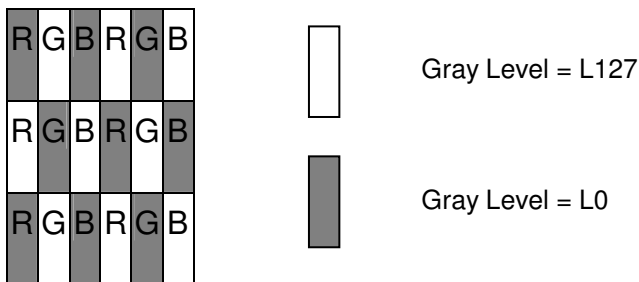

Method: Record dBV & DC value with (WESTAR)TRD-100

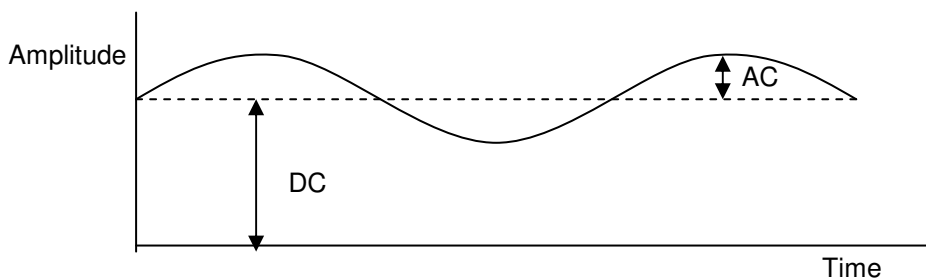

$$\text{Flicker (dB)} = 20 \log \frac{\text{AC Level (at 30 Hz)}}{\text{DC Level}}$$

3.0 Functional Block Diagram

The following diagram shows the functional block of the 24.0 inch Color TFT-LCD Module:

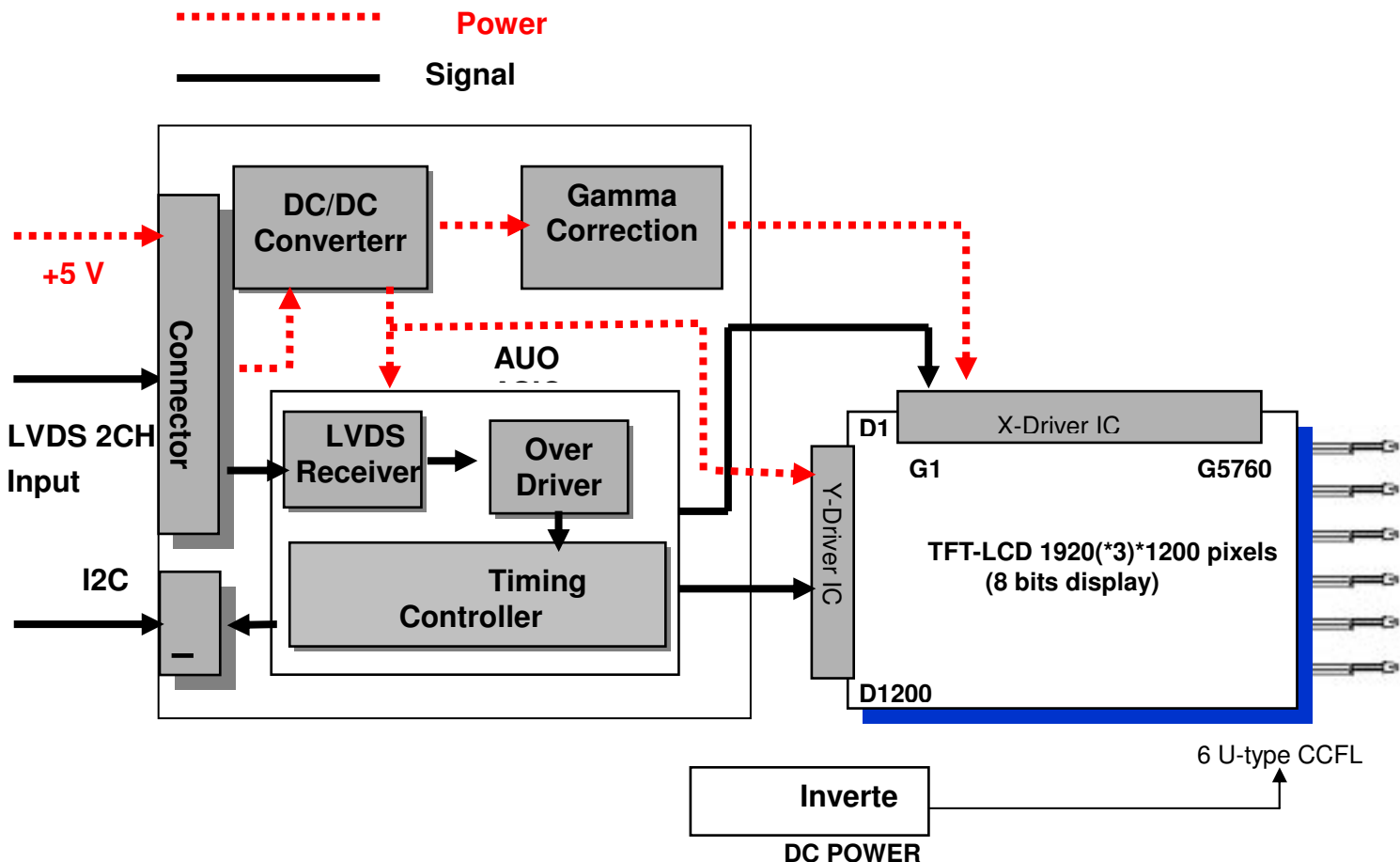

I/F PCB Interface:

JAE FI-XB30SSL-HF15 or compatible

I2C: E&T 3806-B08N-01R or compatible

Mating Type:

FI-X30HL-T (Locked Type)

FI-X30S-H (Unlocked Type)

I2C: Housing: H208-D08N-01B

Terminal: M002-G07N-01R

4.0 Absolute Maximum Ratings

Absolute maximum ratings of the module is as following:

4.1 TFT LCD Module

Item	Symbol	Min	Max	Unit	Conditions
Logic/LCD Drive	VIN	4.5	5.5	[Volt]	<i>Note 1,2</i>

4.2 Backlight Unit

Item	Symbol	Min	Max	Unit	Conditions
CCFL Current	ICFL	2.0	8.0	[mA] rms	<i>Note 1,2</i>

4.3 Absolute Ratings of Environment

Item	Symbol	Min.	Max.	Unit	Conditions
Operating Temperature	TOP	0	+50	[°C]	Note 3
Operation Humidity	HOP	5	90	[%RH]	
Storage Temperature	TST	-20	+60	[°C]	
Storage Humidity	HST	5	90	[%RH]	

Note 1: With in Ta (25°C)

Note 2: Permanent damage to the device may occur if exceed maximum values

Note 3: For quality performance, please refer to AUO IIS(Incoming Inspection Standard).

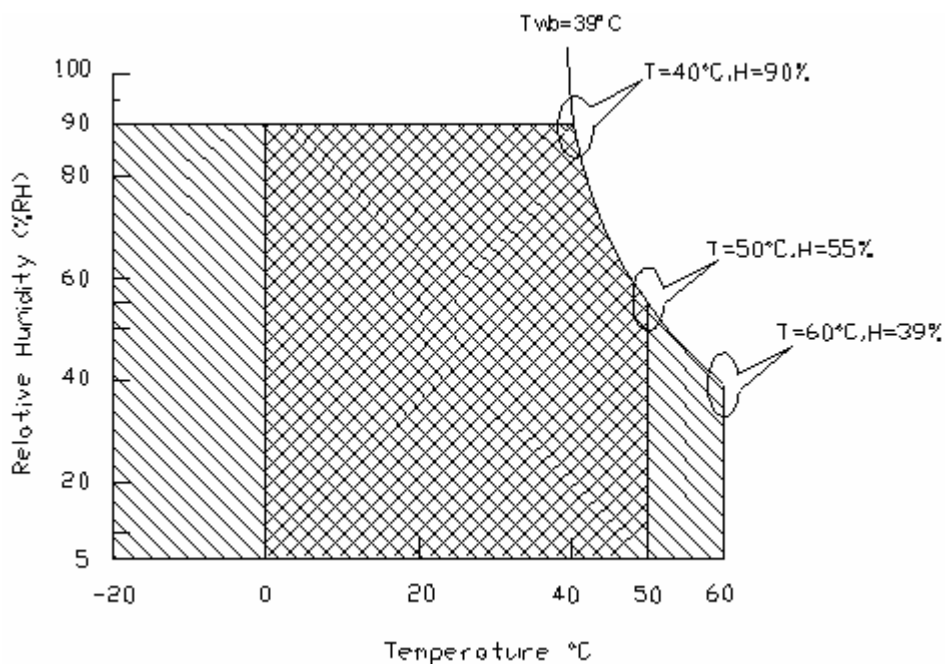

Operating Range



Storage Range

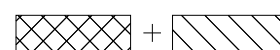

5.0 Electrical characteristics

5.1 TFT LCD Module

5.1.1 Power Specification

Input power specifications are as follows;

Symbol	Parameter	Min	Typ	Max	Units	Condition
VDD	Logic/LCD Drive Voltage	4.75	5.0	5.25	[Volt]	± 5%
IDD (Normal)	VDD current	-	1.8	2.2	[A]	VDD=5V , All White Pattern, at frame rate 60Hz
IDD (SPD)	VDD current	-	2.5	3	[A]	VDD=5V , All White Pattern, at frame rate 60Hz
Irush	LCD Inrush Current	-	-	5	[A]	Note
PDD (Normal)	VDD Power	-	9	11	[Watt]	VDD=5V , All White Pattern, at 60Hz
PDD (SPD)	VDD Power	-	12.5	15	[Watt]	VDD=5V , All White Pattern, at 60Hz

Note: Measurement conditions:

The duration of rising time of power input is 470us.

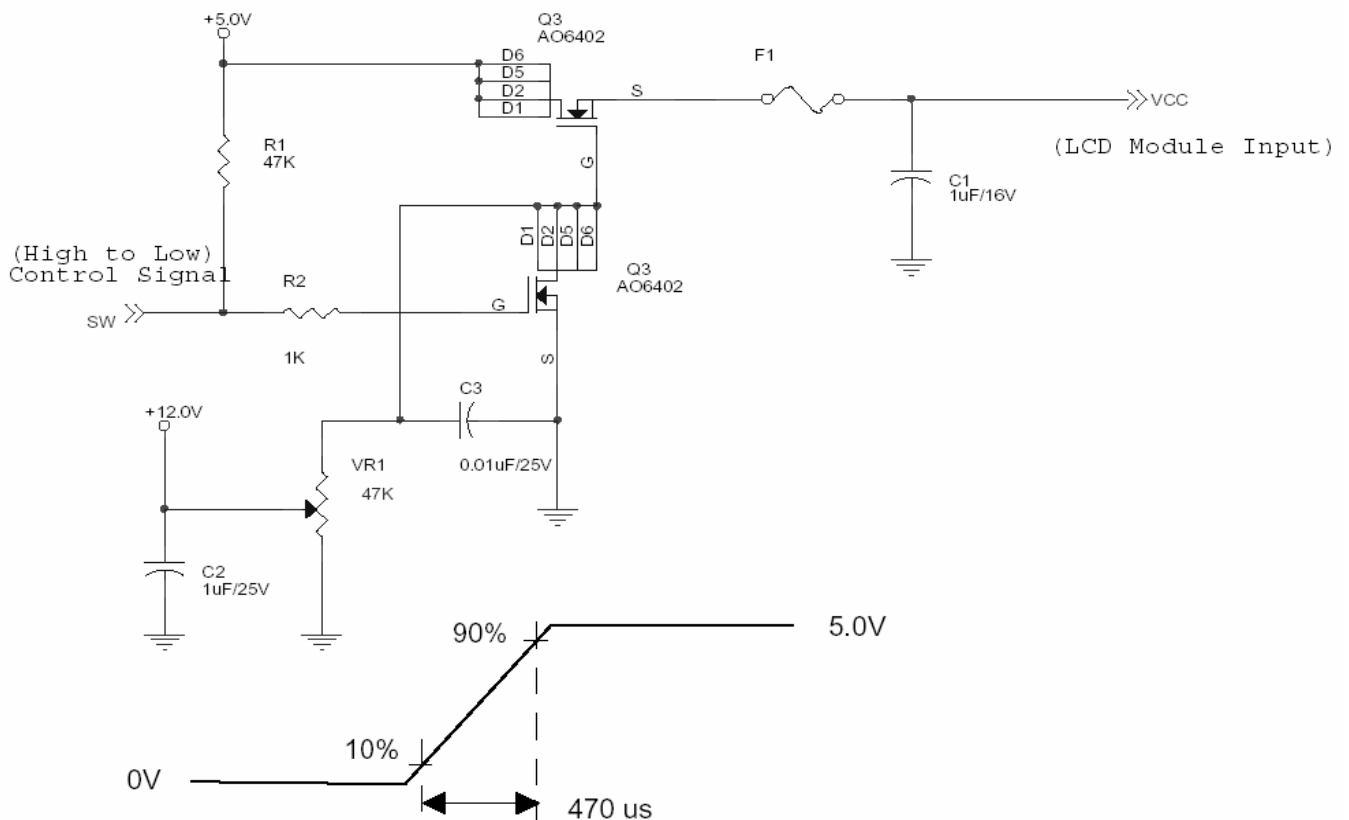

Vin rising time

5.1.2 LVDS Signal Electrical Characteristics

Input signals shall be low or Hi-Z state when V_{in} is off

It is recommended to refer the specifications of SN75LVDS82DGG (Texas Instruments) in detail.

Each signal characteristics are as follows;

Symbol	Parameter	Min	Typ	Max	Units	Condition
VTH	Differential Input High Threshold	-	+50	+100	[mV]	$V_{ICM} = 1.2V$ Note
VTL	Differential Input Low Threshold	-100	-50	-	[mV]	$V_{ICM} = 1.2V$ Note
VID	Input Differential Voltage	100	-	600	[mV]	Note
VICM	Differential Input Common Mode Voltage	+1.0	+1.2	+1.5	[V]	$V_{TH}-V_{TL} = 200mV$ Note

Note: LVDS Signal Waveform

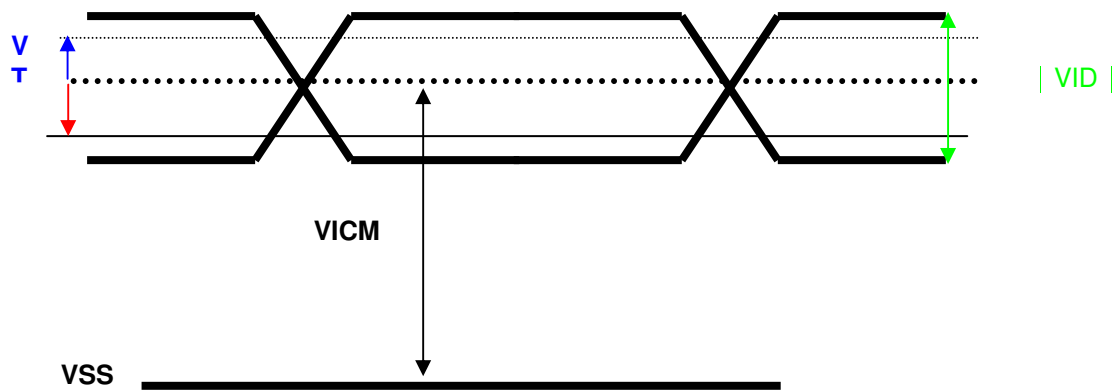

5.1.3 I2C Signal Electrical Characteristics

The I2C specification support sequential read/write and random read/write in the i2c slave function of ASIC.

Support Mode: Fast mode support only.

AC Characteristics

Symbol	Parameter	Min	Max	Unit
f_{SCL}	Clock Frequency, SCL	—	400	kHz
t_{LOW}	Clock Pulse Width Low	1.3	—	us
t_{HIGH}	Clock Pulse Width High	0.6	—	us
t_I	Noise Suppression Time	—	100	us
t_{AA}	Clock Low to Data Out Valid	0.2	0.9	us
t_{BUF}	Time the bus must be free before a new transmission can start	1.3	—	us
$t_{HD.STA}$	Start Hold Time	0.6	—	us
$t_{SU.STA}$	Start Set-up Time	0.6	—	us
$t_{HD.DAT}$	Data In Hold Time	0	—	us
$t_{SU.DAT}$	Data In Set-up Time	100	—	us
t_R	Inputs Rise Time	—	0.3	us
t_F	Inputs Fall Time	—	100	us
$t_{SU.STO}$	Stop Set-up time	0.6	—	us
t_{DH}	Data Out Hold Time	200	—	ns

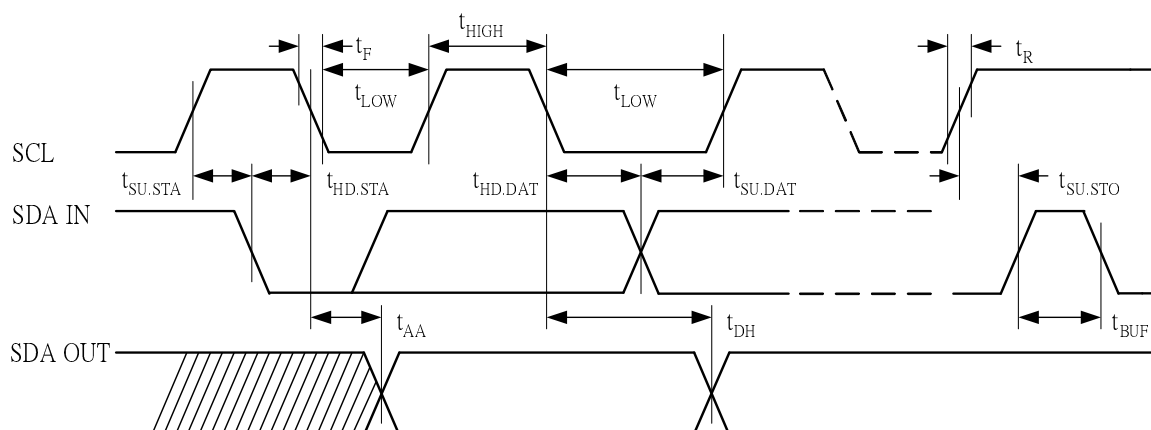

Definition of The Device Address

ASIC Device Address

1	0	1	1	0	0	1	R/W
MSB				LSB			

ASIC Address Mapping

Address(Dec)	Bit Range(7~0)	Function	Note
9	2	nBUSY	1:Enable
			0:Disable
	1	TSEN	1:Enable
			0:Disable
	0	FTM	1:Enable
			0:Disable
4	3	ENBDO	1:Enable
			0:Disable
	2	ENFRC	1:Enable
			0:Disable
	1	ENOD	1:Enable
			0:Disable
	0	ENDG	1:Enable
			0:Disable
45	[7:0]	BDO start LSB	Notea
46	[7:0]	BDO start MSB	Notea

Note a : BDO start value can't not greater than 900 in hexadecimal

FTM

FTM=0, External i2c master cannot access all the function setting in ASIC.

FTM=1, External i2c master can access all function setting registers and sram in ASIC.

The Flow External I2C Master Access ASIC

Vin power and signal sequence is as follows:

1. Power and signal clock must be input
2. FTM must be pulled high first
3. Master write or read must more than 146ms after Signal clock(T2)

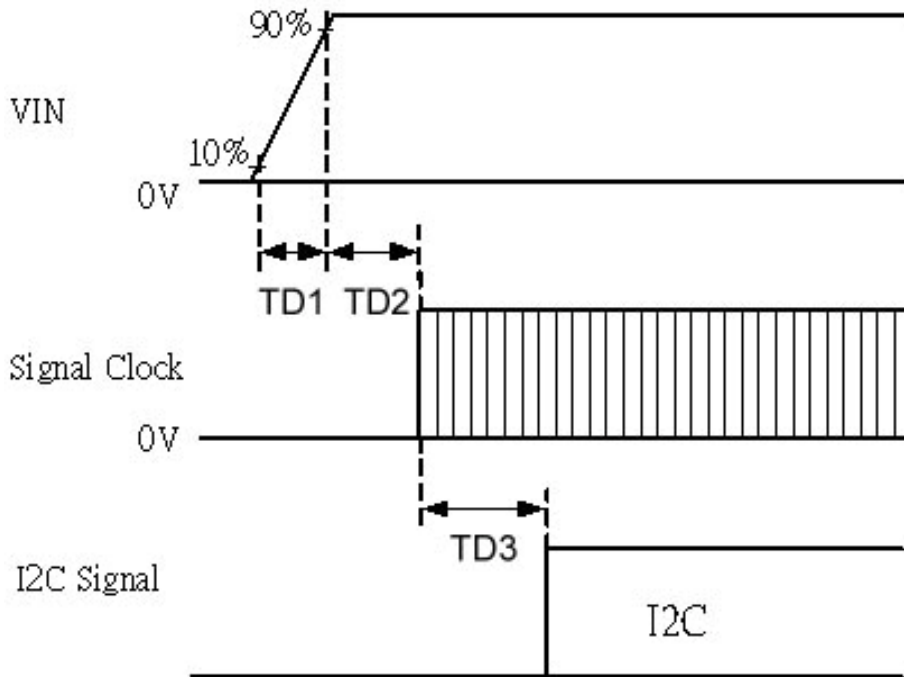

Symbol	Values			Unit
	Min	Typ	Max	
TD1	0.3	-	10	[ms]
TD2	0.5	40	50	[ms]
TD3	146	-	-	[ms]

1. External i2c master write ASIC

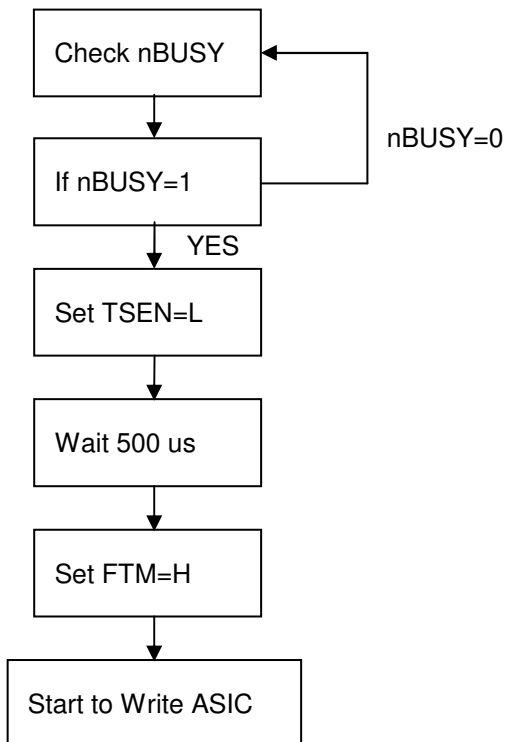

2. External i2c master read ASIC

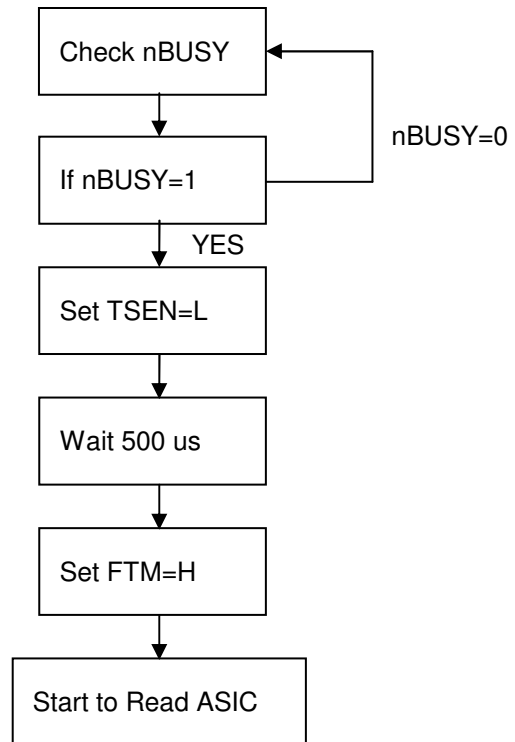

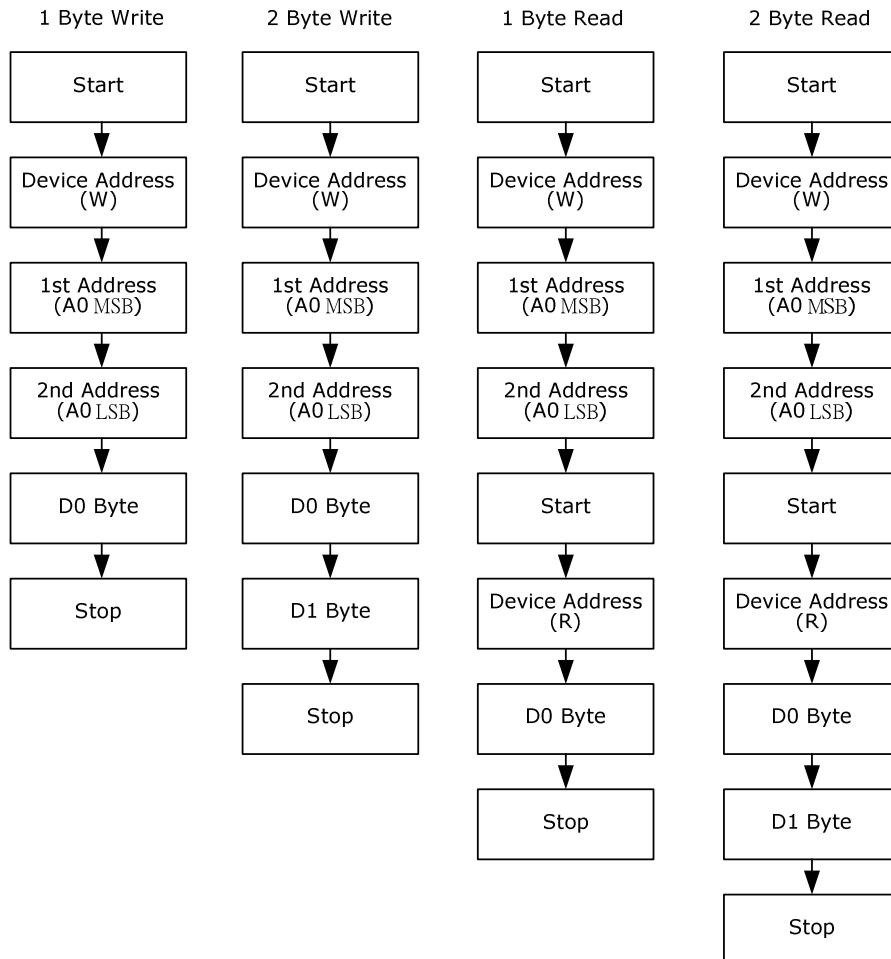

5.2 Backlight Unit

Parameter guideline for CCFL Inverter is under stable conditions at 25°C (Room Temperature):

Parameter	Min.	Typ.	Max.	Unit	Condition
CCFL Operation Current(IRCFL)	2.0	6.0	8.0	[mA] rms	Note 2
CCFL Frequency(FCFL)	40	53	60	[KHz]	Note 3,4
CCFL Ignition Voltage(ViCFL, Ta= 0°C)	2720	-	-	[Volt] rms	Note 5
CCFL Ignition Voltage(ViCF, Ta= 25°C)	2270	-	-	[Volt] rms	
CCFL Operation Voltage (VCFL)	-	1690 (@ 6mA)	-	[Volt] rms	Note 6
CCFL Power Consumption(PCFL)	-	60.8	-	[Watt]	Note 6
CCFL Life Time(LTCFL)	50,000	-	-	[Hour]	Note 7

Note 1: Typ. are AUO recommended design points.

- *1 All of characteristics listed are measured under the condition using the AUO test inverter.
- *2 In case of using an inverter other than listed, it is recommended to check the inverter carefully. Sometimes, interfering noise stripes appear on the screen, and substandard luminance or flicker at low power may happen.
- *3 In designing an inverter, it is suggested to check safety circuit very carefully. Impedance of CCFL, for instance, becomes more than 1 [M ohm] when CCFL is damaged.
- *4 Generally, CCFL has some amount of delay time after applying kick-off voltage. It is recommended to keep on applying kick-off voltage for 1 [Sec] until discharge.
- *5 Reducing CCFL current increases CCFL discharge voltage and generally increases CCFL discharge frequency. So all the parameters of an inverter should be carefully designed so as not to produce too much leakage current from high-voltage output of the inverter.

Note 2: CCFL standard current is measured at 25±2°C.

Note 3: CCFL discharge frequency should be carefully determined to avoid interference between inverter and TFT LCD.

Note 4: The frequency range will not affect to lamp life and reliability characteristics.

Note 5: CCFL inverter should be able to give out a power that has a generating capacity of over 2720 voltage. Lamp units need 2720 voltage minimum for ignition.

Note 6: The variance of CCFL power consumption is ±10%. Calculator value for reference (IRCFL × VCFL × 6 = PCFL)

Note 7: Definition of life time: brightness becomes 50%. The minimum life time of CCFL unit is on the condition of 6mA CCFL current and 25±2°C.

6.0 Signal Characteristic

6.1 Pixel Format Image

Following figure shows the relationship of the input signals and LCD pixel format.

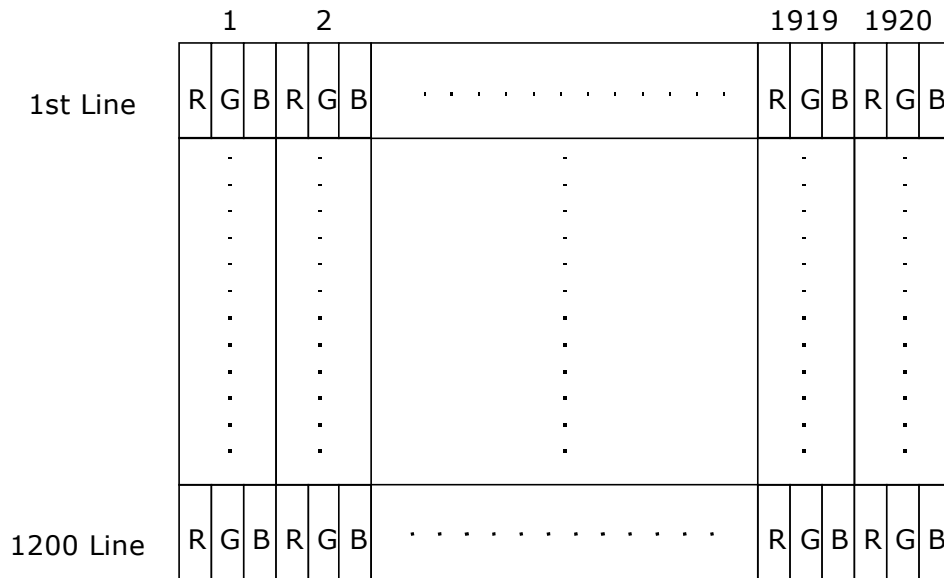

6.2 The input data format

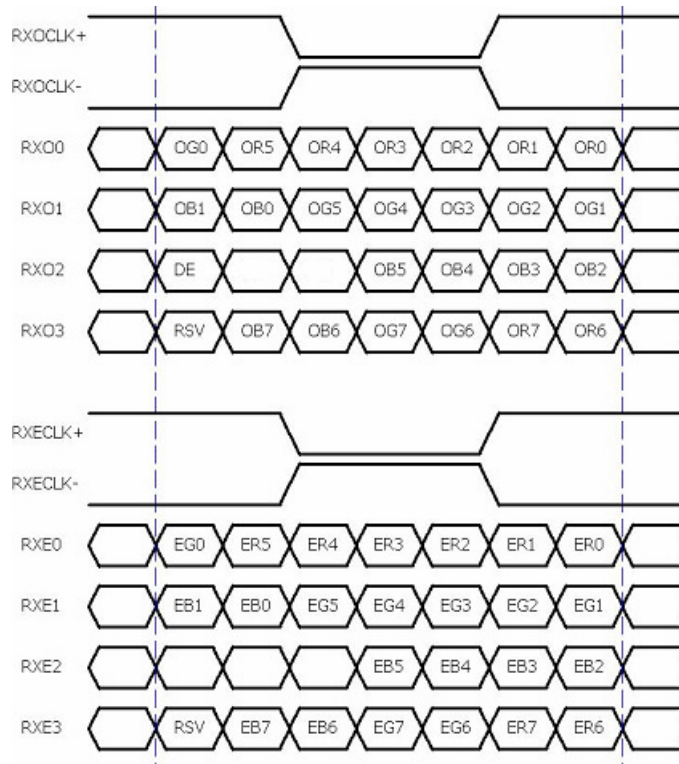

Note 1: R/G/B data 7:MSB, R/G/B data 0:LSB
 O = "First Pixel Data"
 E = "Second Pixel Data"

6.3 Signal Description

The module using one LVDS receiver SN75LVDS82(Texas Instruments) or compatible. LVDS is a differential signal technology for LCD interface and high speed data transfer device. Transmitter shall be SN75LVDS83(negative edge sampling) or compatible. The first LVDS port(RxOxxx) transmits odd pixels while the second LVDS port(RxExxx) transmits even pixels.

PIN #	SIGNAL NAME	DESCRIPTION
1	RxOIN0-	Negative LVDS differential data input (Odd data)
2	RxOIN0+	Positive LVDS differential data input (Odd data)
3	RxOIN1-	Negative LVDS differential data input (Odd data)
4	RxOIN1+	Positive LVDS differential data input (Odd data)
5	RxOIN2-	Negative LVDS differential data input (Odd data, DSPTMG)
6	RxOIN2+	Positive LVDS differential data input (Odd data, DSPTMG)
7	GND	Power Ground
8	RxOCLK-	Negative LVDS differential clock input (Odd clock)
9	RxOCLK+	Positive LVDS differential clock input (Odd clock)
10	RxOIN3-	Negative LVDS differential data input (Odd data)
11	RxOIN3+	Positive LVDS differential data input (Odd data)
12	RxEIN0-	Negative LVDS differential data input (Even data)
13	RxEIN0+	Positive LVDS differential data input (Even data)
14	GND	Power Ground
15	RxEIN1-	Positive LVDS differential data input (Even data)
16	RxEIN1+	Negative LVDS differential data input (Even data)
17	GND	Power Ground
18	RxEIN2-	Negative LVDS differential data input (Even data)
19	RxEIN2+	Positive LVDS differential data input (Even data)
20	RxECLK-	Negative LVDS differential clock input (Even clock)
21	RxECLK+	Positive LVDS differential clock input (Even clock)
22	RxEIN3-	Negative LVDS differential data input (Even data)
23	RxEIN3+	Positive LVDS differential data input (Even data)
24	GND	Power Ground
25	NC	No connection
26	NC	No connection
27	VDD	Power +5V
28	VDD	Power +5V
29	VDD	Power +5V
30	VDD	Power +5V

Note1: Start from left side

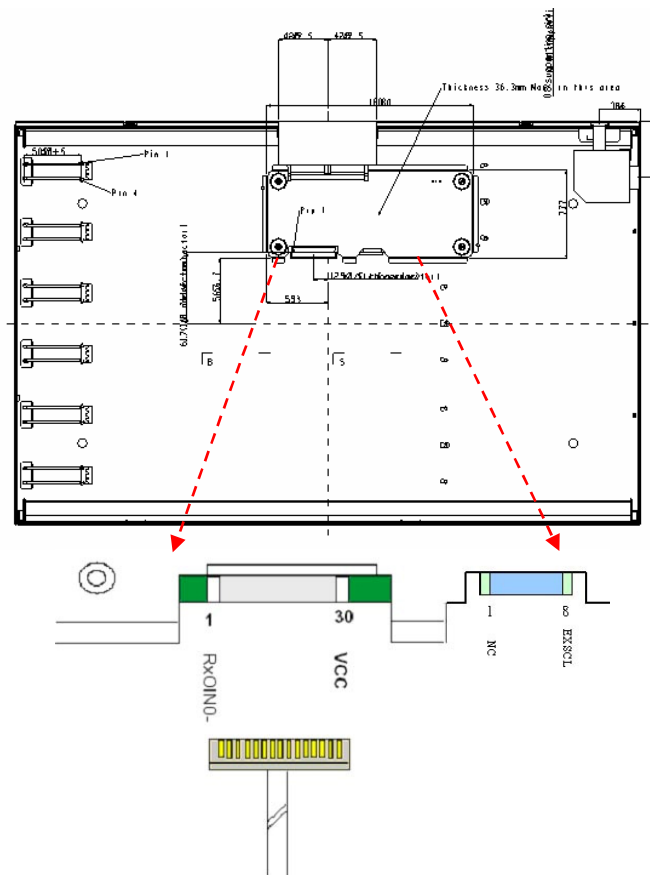

Note2: Input signals of odd and even clock shall be the same timing.

6.4 Timing Characteristics

Basically, interface timings described here is not actual input timing of LCD module but output timing of SN75LVDS82DGG (Texas Instruments) or equivalent.

Note: Typical value refer to VESA STANDARD

Signal	Item	Symbol	Min	Typ	Max	Unit
Vertical Section	Period	Tv	1211	1212	2048	Th
	Active	Tdisp(v)	1200	1200	1200	Th
	Blanking	Tblk(v)	11	12	-	Th
Horizontal Section	Period	Th	1040	1072	1212	Tclk
	Active	Tdisp(h)	960	960	960	Tclk
	Blanking	Tblk(h)	80	112	-	Tclk
Clock	Period	Tclk	11.76	-	-	ns
	Frequency	Freq	-	-	85	MHz
Frame Rate	Frequency	Vsync	47	60	65	Hz

Note : DE mode only

6.5 Timing diagram

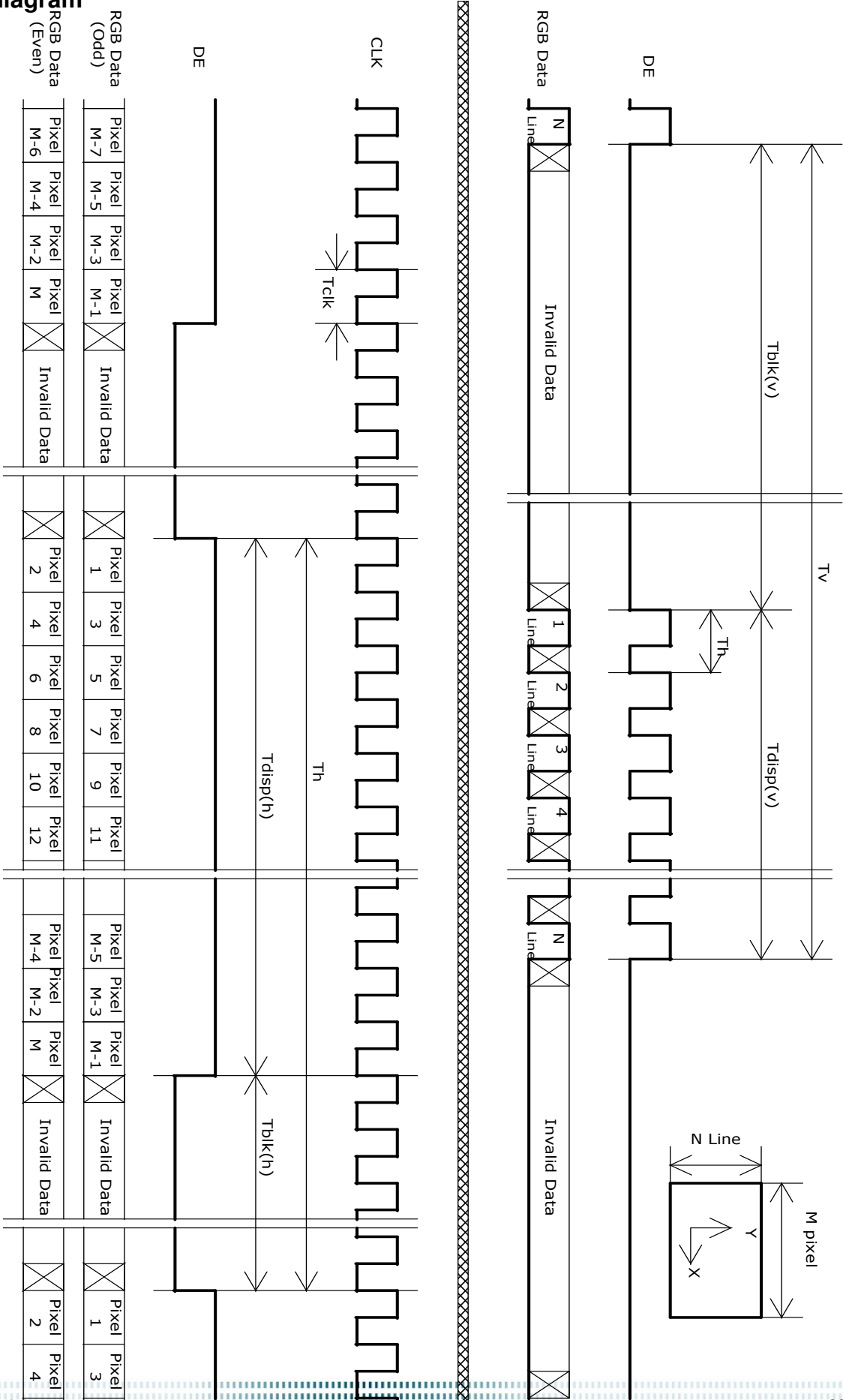

6.6 Power ON/OFF Sequence

Vin power and lamp on/off sequence is as follows. Interface signals are also shown in the chart. Signals from any system shall be Hi-Z state or low level when Vin is off.

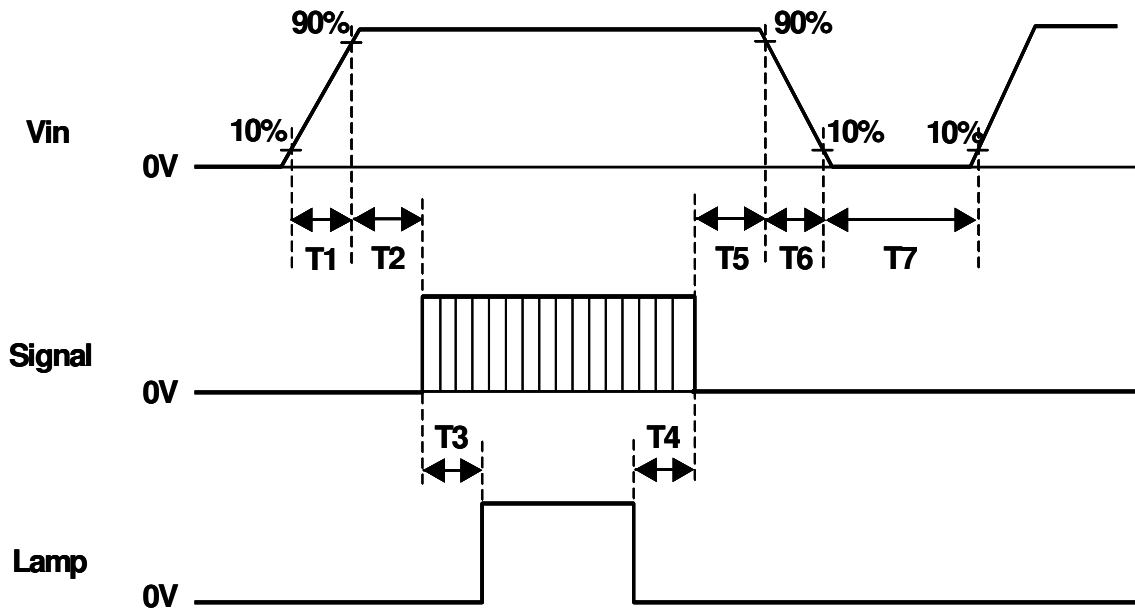

Symbol	Values			Unit
	Min	Typ	Max	
T1	0.5	-	10	[ms]
T2	0.5	40	50	[ms]
T3	300	-	-	[ms]
T4	300	-	-	[ms]
T5	0.5	16	50	[ms]
T6	0.5	-	60	[ms]
T7	1000	-	-	[ms]

7.0 Connector & Pin Assignment

Physical interface is described as for the connector on module.

These connectors are capable of accommodating the following signals and will be following components.

7.1 TFT LCD Module

7.1.1 LVDS Signal Connector and Pin Assignment

Connector Name / Designation	Interface Connector / Interface card
Manufacturer	JAE or compatible
Type Part Number	FI-XB30SSL-HF15
Mating Housing Part Number	FI-X30HL-T (Locked Type)
	FI-X30S-H (Unlocked Type)

Pin Assignment

Pin#	Signal Name	Pin#	Signal Name
1	RxOIN0-	2	RxOIN0+
3	RxOIN1-	4	RxOIN1+
5	RxOIN2-	6	RxOIN2+
7	GND	8	RxOCLKIN-
9	RxOCLKIN+	10	RxOIN3-
11	RxOIN3+	12	RxEIN0-
13	RxEIN0+	14	GND
15	RxEIN1-	16	RxEIN1+
17	GND	18	RxEIN2-
19	RxEIN2+	20	RxECLKIN-
21	RxECLKIN+	22	RxEIN3-
23	RxEIN3+	24	GND
25	NC	26	NC
27	VDD	28	VDD
29	VDD	30	VDD

7.1.2 I2C Signal connector and Pin Assignment

Connector Name / Designation	Interface Connector / Interface card
Manufacturer	E&T or compatible
Type Part Number	3806-B08N-01R
Mating Housing and Part Number	Housing: H208-D08N-01B
	Terminal:M002-G07N-01R

Pin Assignment

PIN #	SIGNAL NAME	DESCRIPTION
1	NC	-
2	NC	-
3	NC	-
4	NC	-
5	NC	-
6	NC	-
7	EXSDA	External I2C Serial Data
8	EXSCL	External I2C Master Clock

7.2 Backlight Unit

Physical interface is described as for the connector on module. These connectors are capable of accommodating the following signals and will be following components.

Connector Name / Designation	Lamp Connector / Backlight lamp
Manufacturer	CVILUX or compatible
Type Part Number	CP0404SLN000
Mating Type Part Number	CP042AP1ML0

7.2.1 Signal for Lamp connector

Connector	Pin No.	Input	Color	Function
CN1	1	Hot	Pink	High Voltage
	4	Hot	White	High Voltage
CN2	1	Hot	Pink	High Voltage
	4	Hot	White	High Voltage
CN3	1	Hot	Pink	High Voltage
	4	Hot	White	High Voltage
CN4	1	Hot	Pink	High Voltage
	4	Hot	White	High Voltage
CN5	1	Hot	Pink	High Voltage
	4	Hot	White	High Voltage
CN6	1	Hot	Pink	High Voltage
	4	Hot	White	High Voltage

8.0 Reliability Test

Environment test conditions are listed as following table.

Items	Required Condition	Note
Temperature Humidity Bias (THB)	Ta= 50°C, 80%RH, 300hours	
High Temperature Operation (HTO)	Ta= 50°C, 50%RH, 300hours	
Low Temperature Operation (LTO)	Ta= 0°C, 300hours	
High Temperature Storage (HTS)	Ta= 60°C, 300hours	
Low Temperature Storage (LTS)	Ta= -20°C, 300hours	
Vibration Test (Non-operation)	Acceleration: 1.5 G Wave: Half-sine Frequency: 10 - 300 - 10 Hz Sweep: 30 Minutes each Axis (X, Y, Z)	
Shock Test (Non-operation)	Acceleration: 50 G Wave: Half-sine Active Time: 11 ms Direction: ±X, ±Y, ±Z (one time for each Axis)	
Drop Test	Height: 60 cm, package test	
Thermal Shock Test (TST)	-20°C/30min, 60°C/30min, 100 cycles	1
On/Off Test	On/10sec, Off/10sec, 30,000 cycles	
ESD (ElectroStatic Discharge)	Contact Discharge: ± 8KV, 150pF(330Ω) 1sec, 8 points, 25 times/ point.	2
	Air Discharge: ± 15KV, 150pF(330Ω) 1sec 8 points, 25 times/ point.	
Altitude Test	Operation:10,000 ft Non-Operation:30,000 ft	

Note 1: The TFT-LCD module will not sustain damage after being subjected to 100 cycles of rapid temperature change. A cycle of rapid temperature change consists of varying the temperature from -20°C to 60°C, and back again. Power is not applied during the test. After temperature cycling, the unit is placed in normal room ambient for at least 4 hours before power on.

Note 2: According to EN61000-4-2 , ESD class B: Some performance degradation allowed. No data lost. Self-recoverable. No hardware failures.

9.0 Shipping Label

The label is on the panel as shown below:



10.0 Mechanical Characteristics

