



- CONTENTS -

REVISION HISTORY .....	3
1. GENERAL DESCRIPTION .....	4
1.1 OVERVIEW	
1.2 FEATURES	
1.3 APPLICATION	
1.4 GENERAL SPECIFICATIONS	
1.5 MECHANICAL SPECIFICATIONS	
2. ABSOLUTE MAXIMUM RATINGS .....	5
2.1 ABSOLUTE RATINGS OF ENVIRONMENT	
2.2 ELECTRICAL ABSOLUTE RATINGS	
2.2.1 TFT LCD MODULE	
2.2.2 BACKLIGHT UNIT	
3. ELECTRICAL CHARACTERISTICS .....	7
3.1 TFT LCD MODULE	
3.2 BACKLIGHT UNIT	
4. BLOCK DIAGRAM .....	10
4.1 TFT LCD MODULE	
4.2 BACKLIGHT UNIT	
5. INPUT TERMINAL PIN ASSIGNMENT .....	11
5.1 TFT LCD MODULE	
5.2 BACKLIGHT UNIT	
5.3 COLOR DATA INPUT ASSIGNMENT	
6. INVERTER SPECIFICATIONS.....	14
6.1 INVERTER CHARACTERISTICS	
6.2 INVERTER INTERFACE CHARACTERISTICS	
6.3 INVERTER PIN ASSIGNMENT	
7. INTERFACE TIMING .....	17
7.1 INPUT SIGNAL TIMING SPECIFICATIONS	
7.2 POWER ON/OFF SEQUENCE	
7.3 VDD POWER DIP CONDITION	
8. OPTICAL CHARACTERISTICS .....	20
8.1 TEST CONDITIONS	
8.2 OPTICAL SPECIFICATIONS	
9. PACKAGING .....	21
9.1 PACKING SPECIFICATIONS	
9.2 PACKING METHOD	
10. DEFINITION OF LABELS .....	23
11. PRECAUTIONS .....	24
11.1 ASSEMBLY AND HANDLING PRECAUTIONS	
11.2 SAFETY PRECAUTIONS	
12. MECHANICAL CHARACTERISTICS.....	25

REVISION HISTORY

Version	Date	Section	Description
Ver 1.0	4 <sup>th</sup> , Jan., 2011	All	G15411-LE1 Preliminary specification was first issued.

## 1. GENERAL DESCRIPTION

### 1.1 OVERVIEW

The G154I1-LE1 model is a 15.4" TFT-LCD module with a white LED Backlight Unit and a 30-pin 1ch-LVDS interface. This module supports 1280 x 800 WXGA mode and displays 262k/16.2M colors. The converter for the Backlight Unit is built in.

### 1.2 FEATURES

- WXGA (1280 x 800 pixels) resolution
- Wide operating temperature
- DE (Data Enable) mode
- LVDS (Low Voltage Differential Signaling) interface
- RoHS Compliance
- LED Light Bar Replaceable
- Reverse Scan

### 1.3 APPLICATION

- TFT LCD Monitor
- Industrial Application
- Amusement

### 1.4 GENERAL SPECIFICATIONS

Item	Specification	Unit	Note
Diagonal Size	15.4	inch	(1)
Active Area	331.2(H) x 207.0(V)	mm	
Bezel Opening Area	334.5 x 210.3	mm	
Driver Element	a-si TFT active matrix	-	-
Pixel Number	1280 x R.G.B. x 800	pixel	-
Pixel Pitch	0.259(H) x 0.259(V)	mm	-
Pixel Arrangement	RGB vertical stripe	-	-
Display Colors	262k/16.2M	color	-
Transmissive Mode	Normally white	-	-
Surface Treatment	AG, 3H	-	-

1.5 MECHANICAL SPECIFICATIONS

Item		Min.	Typ.	Max.	Unit	Note
Module Size	Horizontal (H)	351.5	352	352.5	mm	(1)
	Vertical (V)	229.5	230	230.5	mm	
	Depth (D)	8.5	9	9.5	mm	
Weight			880		g	-
I/F connector mounting position		The mounting inclination of the connector makes the screen center within $\pm 0.5\text{mm}$ as the horizontal.			-	(2)

Note (1) Please refer to the attached drawings for more information of front and back outline dimensions.

(2) Connector mounting position

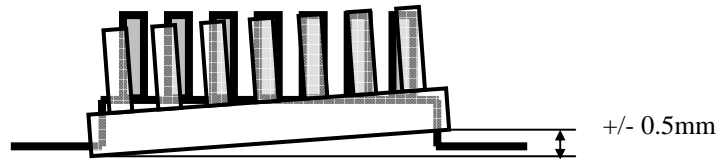

2. ABSOLUTE MAXIMUM RATINGS

2.1 ABSOLUTE RATINGS OF ENVIRONMENT

Item	Symbol	Value		Unit	Note
		Min.	Max.		
Operating Ambient Temperature	$T_{OP}$	-30	+70	$^{\circ}\text{C}$	
Storage Temperature	$T_{ST}$	-30	+80	$^{\circ}\text{C}$	

Note Temperature and relative humidity range is shown in the figure below.

- (a) 90 %RH Max. ( $T_a \leq 40^{\circ}\text{C}$ ).
- (b) Wet-bulb temperature should be  $39^{\circ}\text{C}$  Max. ( $T_a > 40^{\circ}\text{C}$ ).
- (c) No condensation.

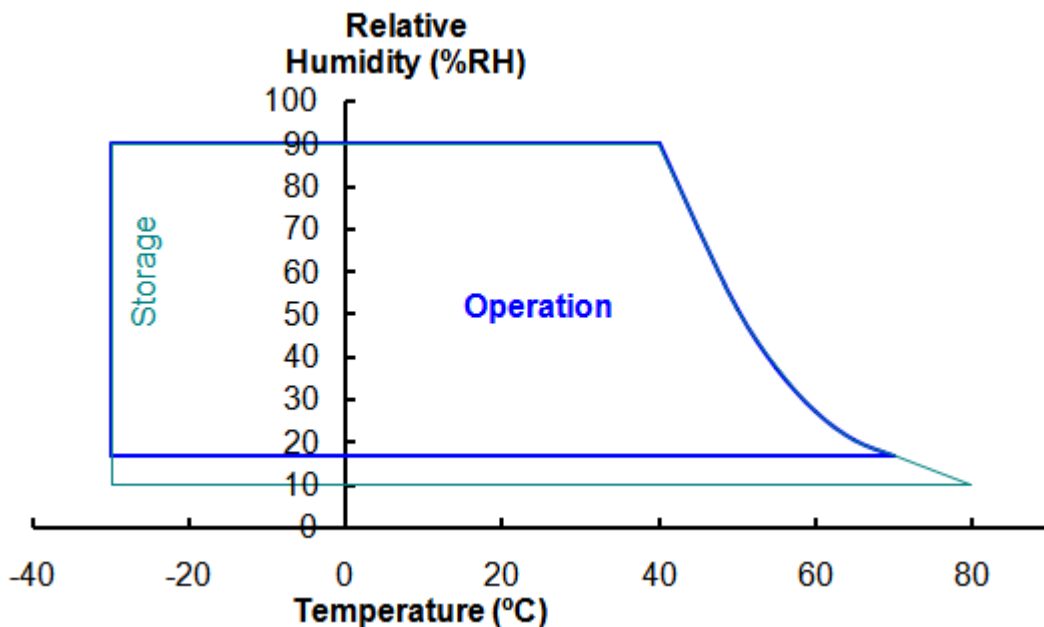

## 2.2 ELECTRICAL ABSOLUTE RATINGS

### 2.2.1 TFT LCD MODULE

Item	Symbol	Value		Unit	Note
		Min.	Max.		
Power Supply Voltage	V <sub>CC</sub>	-0.3	4.0	V	(1)
Logic Input Voltage	V <sub>IN</sub>	-0.3	V <sub>CC</sub> +0.3	V	(1)

### 2.2.2 BACKLIGHT UNIT

Item	Value			Unit	Note
	Min	Typ.	Max.		
LED Light Bar Input voltage	-	28	-	V <sub>DC</sub>	(1), (2)
LED Light Bar Input Current	-	320	-	mA <sub>DC</sub>	

Note (1) Permanent damage to the device may occur if maximum values are exceeded. Function operation should be restricted to the conditions described under Normal Operating Conditions.

Note (2) Specified values are for LED (Refer to Section 3.2 for further information).

3. ELECTRICAL CHARACTERISTICS

3.1 TFT LCD MODULE

Ta = 25 ± 2 °C

Parameter	Symbol	Value			Unit	Note	
		Min.	Typ.	Max.			
Power Supply Voltage	Vcc	3.0	3.3	3.6	V	at Vcc=3.3V	
Ripple Voltage	V <sub>RP</sub>	-	50		mV	-	
Rush Current	I <sub>RUSH</sub>	-	-	1.5	A	(2)	
Initial Stage Current	I <sub>IS</sub>	-	-	1.0	A	(2)	
Power Supply Current	White	I <sub>CC</sub>	-	400	500	mA	(3)a, at Vcc=3.3V
	Black		-	550	650	mA	(3)b, at Vcc=3.3V
LVDS Differential Input High Threshold	V <sub>TH</sub> (LVDS)	-	-	+100	mV	V <sub>CM</sub> =1.2V	
LVDS Differential Input Low Threshold	V <sub>TL</sub> (LVDS)	-100	-	-	mV	V <sub>CM</sub> =1.2V	
LVDS Common Mode Voltage	V <sub>CM</sub>	1.125	-	1.375	V		
LVDS Differential Input Voltage	V <sub>ID</sub>	100	-	600	mV		
Terminating Resistor	R <sub>T</sub>	-	100	-	Ohm		

Note (1) The assembly should be always operated within above ranges.

Note (2) Measurement Conditions:

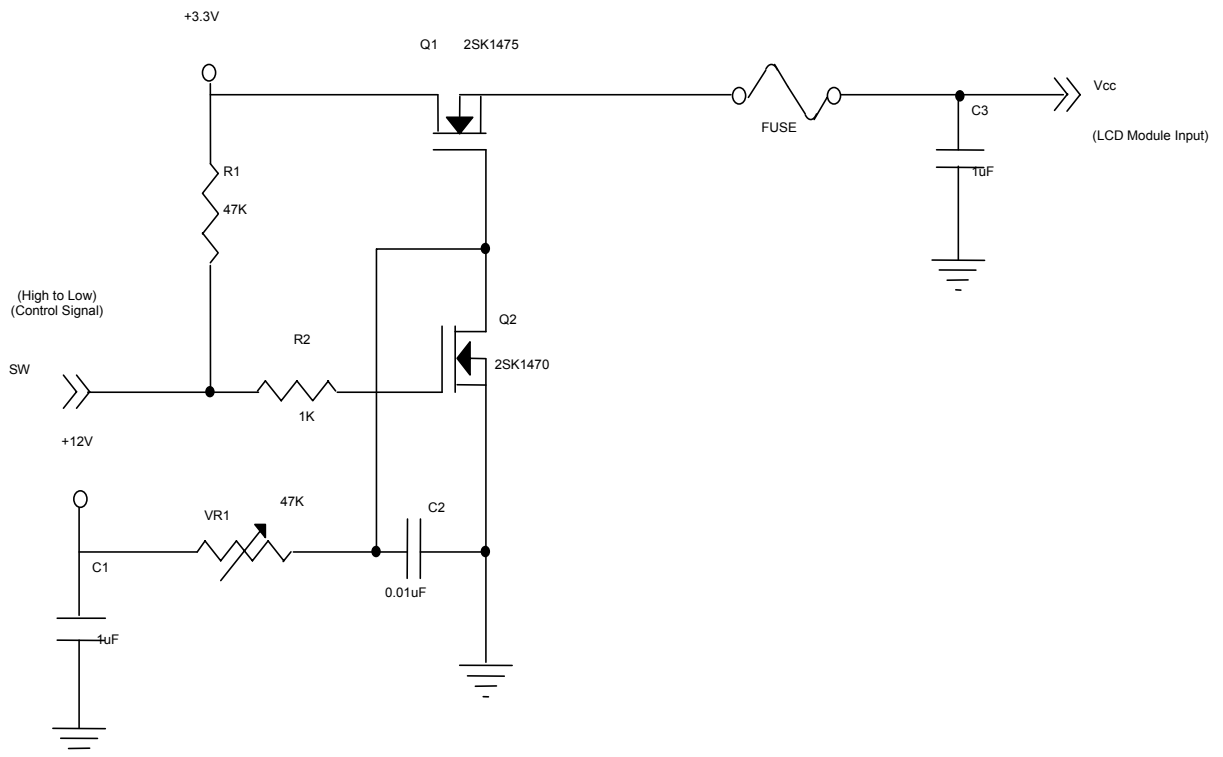

**VCC rising time is 470us**

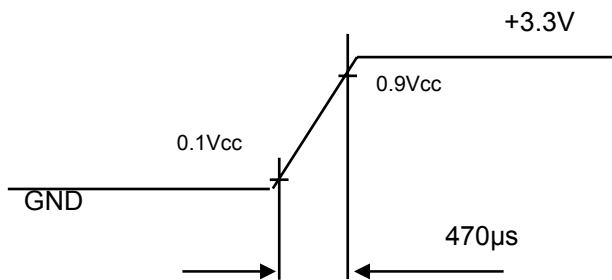

Note (3) The specified power supply current is under the conditions at V<sub>cc</sub> = 3.3 V, T<sub>a</sub> = 25 ± 2 °C, f<sub>v</sub> = 60 Hz, whereas a power dissipation check pattern below is displayed.

a. White Pattern

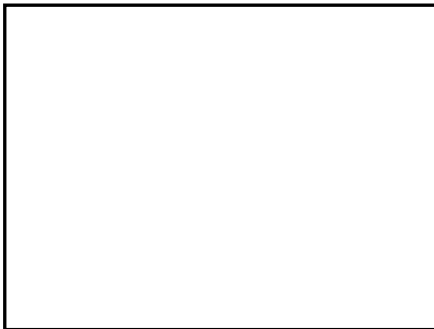

Active Area

b. Black Pattern

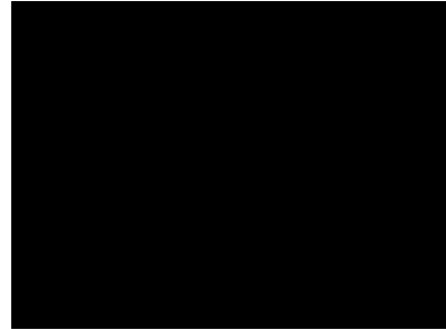

Active Area

c. Vertical Stripe Pattern

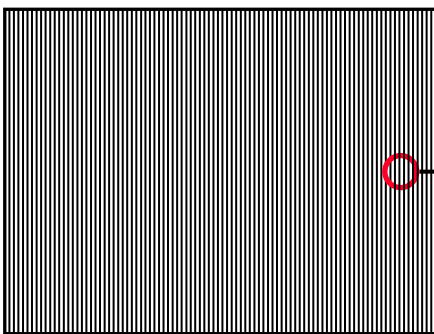

Active Area

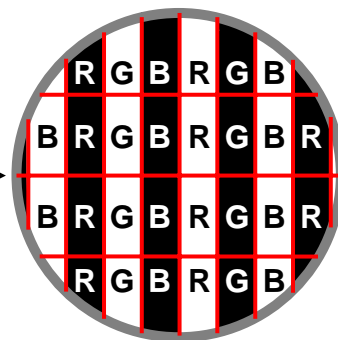

3.2 BACKLIGHT UNIT

Ta = 25 ± 2 °C

Parameter	Symbol	Value			Unit	Note	
		Min.	Typ.	Max.			
Converter Power Supply Voltage	V <sub>i</sub>	10.8	12.0	13.2	V	(Duty 100%)	
Converter Power Supply Current	I <sub>i</sub>	750	850	950	mA	@ V <sub>i</sub> = 12V (Duty 100%)	
LED Power Consumption	P <sub>LED</sub>	9.0	10.2	11.4	W	@ V <sub>i</sub> = 12V (Duty 100%)	
EN Control Level	Backlight on	BLU_EN	2.0	---	3.3	V	
	Backlight off		0	---	0.8	V	
PWM Control Level	PWM High Level	BLU_ADJ	2.0	---	3.3	V	
	PWM Low Level		0	---	0.15	V	
PWM Control Duty Ratio			20		100	%	
PWM Control Frequency	f <sub>PWM</sub>		190	200	210	Hz	
LED Input Voltage	V <sub>f</sub>		-	3.2	-	V <sub>DC</sub>	I <sub>f</sub> = 80 mA/EA
LED Current	I <sub>f</sub>		-	80	-	mA	Per EA
LED Life Time	L <sub>L</sub>		50,000			Hrs	(1)

Note (1) LED current is measured by utilizing a high frequency current meter as shown below:

Note (2) The lifetime of LED is defined as the time when it continues to operate under the conditions at Ta = 25 ± 2 and I<sub>LED</sub> = 80mA<sub>DC</sub>(LED forward current) until the brightness becomes 50% of its original value. Operating LED under high temperature environment will reduce life time and lead to color shift.

Note (3) P<sub>L</sub> = I<sub>o</sub> × V<sub>o</sub>.

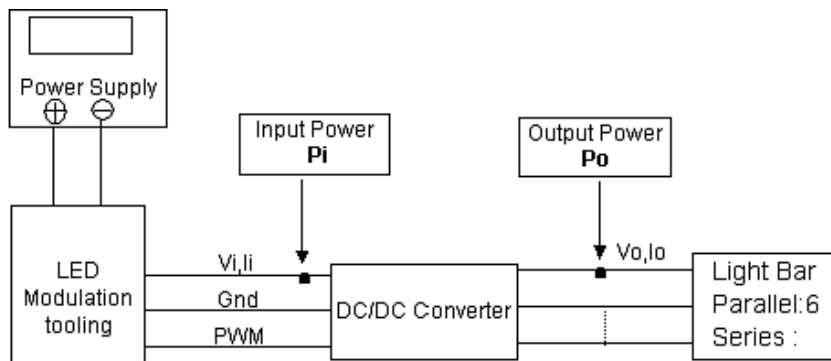

4. BLOCK DIAGRAM

4.1 TFT LCD MODULE

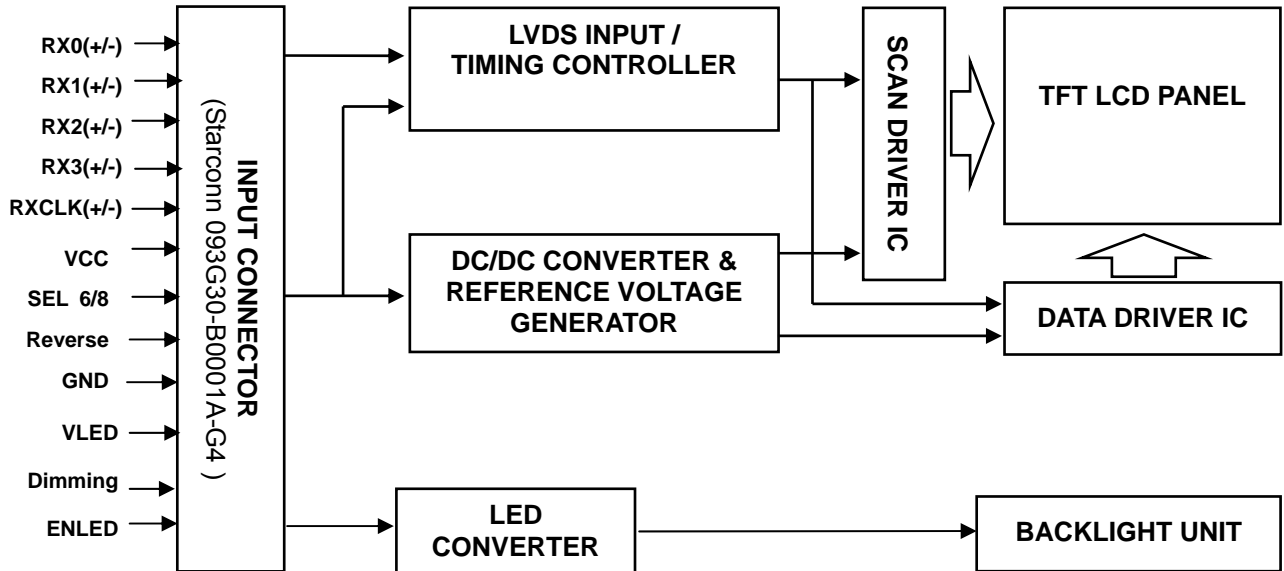

5. INPUT TERMINAL PIN ASSIGNMENT

5.1 TFT LCD MODULE

Pin	Name	Description	Remark
1	12V	LED Power supply	LED converter power
2	12V	LED Power supply	
3	12V	LED Power supply	
4	12V	LED Power supply	
5	ENLED	Enable Pin	
6	Dimming	Backlight Adjust	
7	GND	Ground	
8	GND	Ground	
9	VCC	Power supply +3.3V	System power
10	VCC	Power supply +3.3V	
11	GND	Ground	
12	GND	Ground	
13	RX0-	Differential Data Input, CH0 (Negative )	
14	RX0+	Differential Data Input, CH0 ( Positive )	
15	GND	Ground	
16	RX1-	Differential Data Input, CH1 ( Negative )	
17	RX1+	Differential Data Input , CH1 ( Positive )	
18	GND	Ground	
19	RX2-	Differential Data Input , CH2 ( Negative )	
20	RX2+	Differential Data Input , CH2 ( Positive )	
21	GND	Ground	
22	RXCLK-	Differential Clock Input ( Negative )	
23	RXCLK+	Differential Clock Input ( Positive )	
24	GND	Ground	
25	RX3-	Differential Data Input, CH3 (Negative )	
26	RX3+	Differential Data Input, CH3 ( Positive )	
27	GND	Ground	
28	SEL6/8	LVDS 6/8 bit select function control, Low or NC → 6 bit Input Mode High → 8bit Input Mode	(2)
29	Reverse	Scanning direction control	(2)
		Low or NC → normal display (default)	
		High → display with 180 degree rotation	
30	GND	Ground	

Note (1) Connector Part No.: STARCONN 093G30-B1001A-G4 or equivalent.

Note (2) “Low” stands for 0V. “High” stands for 3.3V. “NC” stands for “No Connected”.

5.2 SCANNING DIRECTION

The following figures are seen from a front view and the arrow shows the direction of scan.

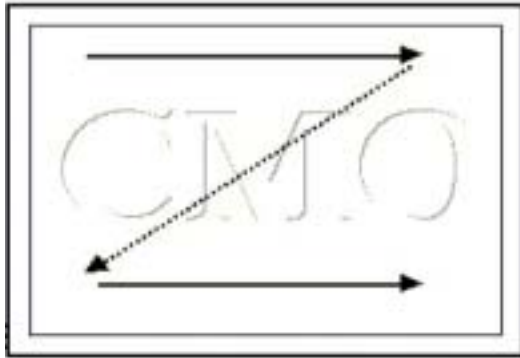

Reverse = GND/NC : normal display (default)

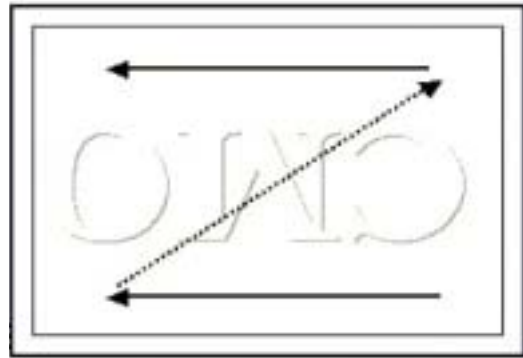

Reverse = High : display with 180 degree rotation

5.3 COLOR DATA INPUT ASSIGNMENT

The brightness of each primary color (red, green and blue) is based on the 6-bit gray scale data input for the color. The higher the binary input, the brighter the color. The table below provides the assignment of color versus data input.

Color		Data Signal																	
		Red						Green						Blue					
		R5	R4	R3	R2	R1	R0	G5	G4	G3	G2	G1	G0	B5	B4	B3	B2	B1	B0
Basic Colors	Black	0	0	0	0	0	0	0	0	0	0	0	0	0	0	0	0	0	0
	Red	1	1	1	1	1	1	0	0	0	0	0	0	0	0	0	0	0	0
	Green	0	0	0	0	0	0	1	1	1	1	1	1	0	0	0	0	0	0
	Blue	0	0	0	0	0	0	0	0	0	0	0	0	1	1	1	1	1	1
	Cyan	0	0	0	0	0	0	1	1	1	1	1	1	1	1	1	1	1	1
	Magenta	1	1	1	1	1	1	0	0	0	0	0	0	1	1	1	1	1	1
	Yellow	1	1	1	1	1	1	1	1	1	1	1	1	0	0	0	0	0	0
	White	1	1	1	1	1	1	1	1	1	1	1	1	1	1	1	1	1	1
	Gray Scale Of Red	Red(0)/Dark	0	0	0	0	0	0	0	0	0	0	0	0	0	0	0	0	0
Red(1)		0	0	0	0	0	1	0	0	0	0	0	0	0	0	0	0	0	0
Red(2)		0	0	0	0	1	0	0	0	0	0	0	0	0	0	0	0	0	0
:		:	:	:	:	:	:	:	:	:	:	:	:	:	:	:	:	:	:
:		:	:	:	:	:	:	:	:	:	:	:	:	:	:	:	:	:	:
Red(61)		1	1	1	1	0	1	0	0	0	0	0	0	0	0	0	0	0	0
Red(62)		1	1	1	1	1	0	0	0	0	0	0	0	0	0	0	0	0	0
Red(63)	1	1	1	1	1	1	0	0	0	0	0	0	0	0	0	0	0	0	
Gray Scale Of Green	Green(0)/Dark	0	0	0	0	0	0	0	0	0	0	0	0	0	0	0	0	0	0
	Green(1)	0	0	0	0	0	0	0	0	0	0	1	0	0	0	0	0	0	0
	Green(2)	0	0	0	0	0	0	0	0	0	0	1	0	0	0	0	0	0	0
	:	:	:	:	:	:	:	:	:	:	:	:	:	:	:	:	:	:	:
	:	:	:	:	:	:	:	:	:	:	:	:	:	:	:	:	:	:	:
	Green(61)	0	0	0	0	0	0	1	1	1	1	0	1	0	0	0	0	0	0
	Green(62)	0	0	0	0	0	0	1	1	1	1	1	0	0	0	0	0	0	0
Green(63)	0	0	0	0	0	0	1	1	1	1	1	1	0	0	0	0	0	0	

	Blue(0)/Dark	0	0	0	0	0	0	0	0	0	0	0	0	0	0	0	0	0	0
	Blue(1)	0	0	0	0	0	0	0	0	0	0	0	0	0	0	0	0	0	1
Gray	Blue(2)	0	0	0	0	0	0	0	0	0	0	0	0	0	0	0	0	1	0
Scale	:	:	:	:	:	:	:	:	:	:	:	:	:	:	:	:	:	:	:
Of	:	:	:	:	:	:	:	:	:	:	:	:	:	:	:	:	:	:	:
Blue	Blue(61)	0	0	0	0	0	0	0	0	0	0	0	1	1	1	1	0	1	
	Blue(62)	0	0	0	0	0	0	0	0	0	0	0	1	1	1	1	1	0	
	Blue(63)	0	0	0	0	0	0	0	0	0	0	0	1	1	1	1	1	1	

Note (1) 0: Low Level Voltage, 1: High Level Voltage

6. INTERFACE TIMING

6.1 INPUT SIGNAL TIMING SPECIFICATIONS

The input signal timing specifications are shown as the following table and timing diagram.

Signal	Item	Symbol	Min.	Typ.	Max.	Unit	Note
DCLK	Frequency	1/Tc	67.45	71	74.55	MHz	-
DE	Vertical Total Time	TV	810	823	1000	TH	-
	Vertical Addressing Time	TVD	800	800	800	TH	-
	Horizontal Total Time	TH	1360	1440	1600	Tc	-
	Horizontal Addressing Time	THD	1280	1280	1280	Tc	-

Note : (1) Because this module is operated by DE only mode, Hsync and Vsync input signals should be set to low logic level or ground. Otherwise, this module would operate abnormally.

**INPUT SIGNAL TIMING DIAGRAM**

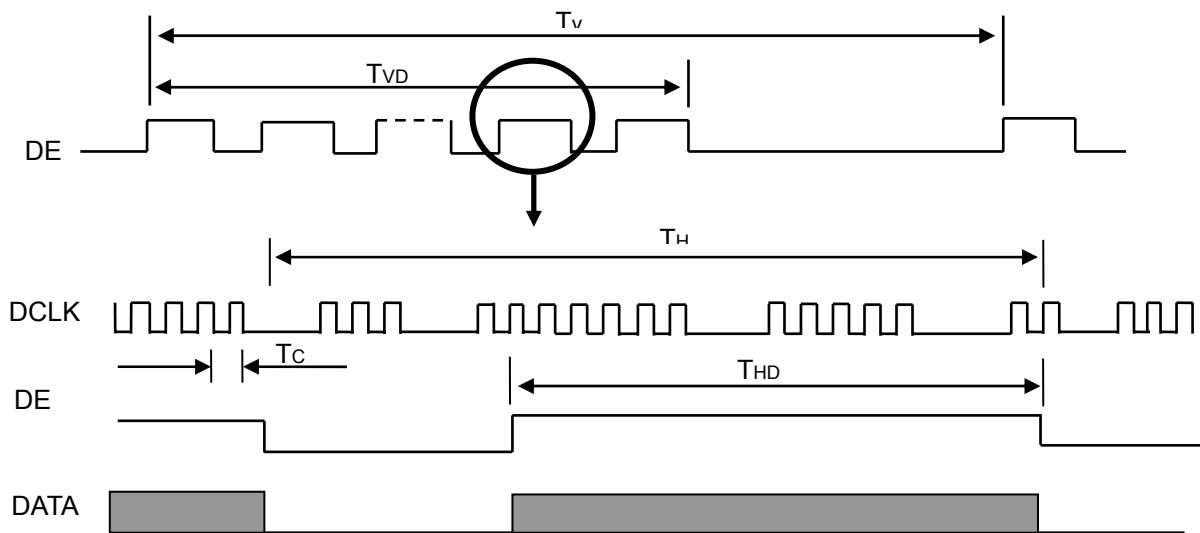

6.2 POWER ON/OFF SEQUENCE

To prevent a latch-up or DC operation of LCD assembly, the power on/off sequence should be as the diagram below.

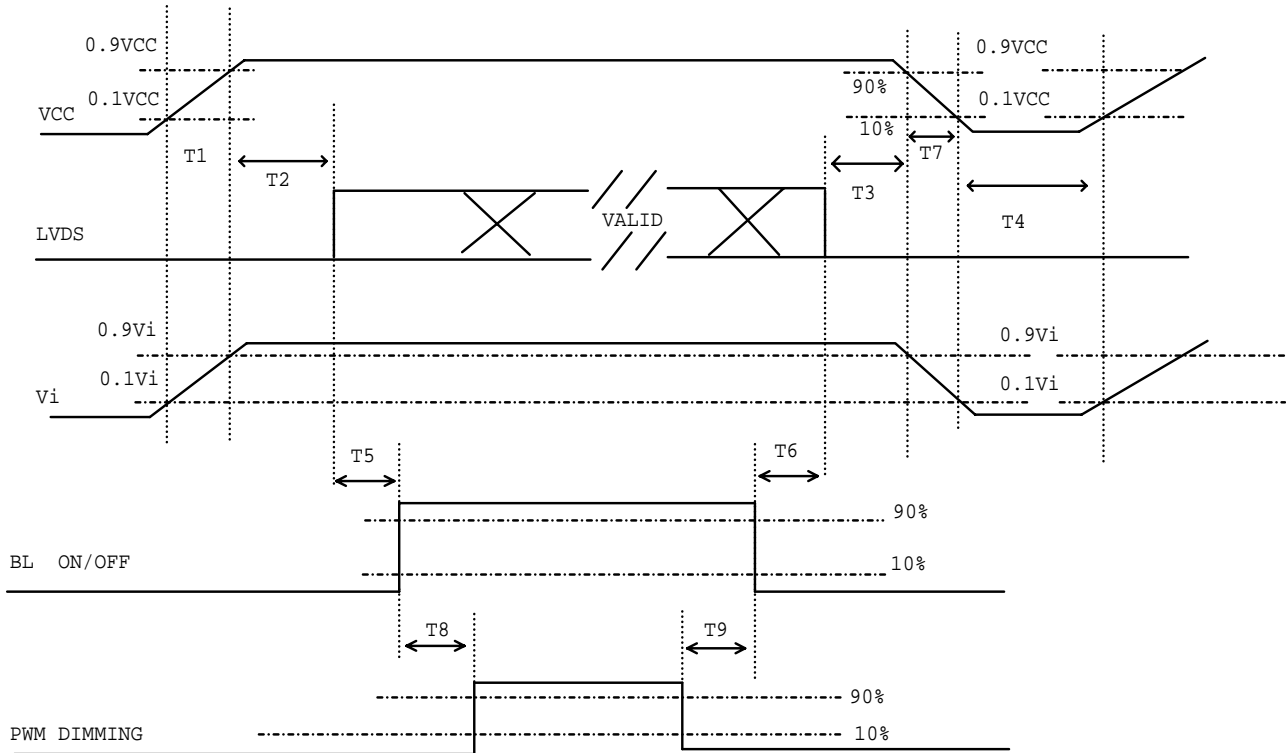

**Power ON/OFF sequence**

Note (1) Please avoid floating state of interface signal at invalid period.

Note (2) When the interface signal is invalid, be sure to pull down the power supply of LCD VCC to 0 V.

Note (3) The Backlight converter power must be turned on after the power supply for the logic and the interface signal is valid. The Backlight converter power must be turned off before the power supply for the logic and the interface signal is invalid.

Parameter	Value			Units
	Min	Typ	Max	
<b>T1</b>	<b>0.5</b>	-	<b>10</b>	<b>ms</b>
<b>T2</b>	<b>0</b>	-	<b>50</b>	<b>ms</b>
<b>T3</b>	<b>0</b>	-	<b>50</b>	<b>ms</b>
<b>T4</b>	<b>500</b>	-	-	<b>ms</b>
<b>T5</b>	<b>200</b>	-	-	<b>ms</b>
<b>T6</b>	<b>20</b>	-	-	<b>ms</b>
<b>T7</b>	<b>5</b>	-	<b>300</b>	<b>ms</b>
<b>T8</b>	<b>10</b>	-	-	<b>ms</b>
<b>T9</b>	<b>10</b>	-	-	<b>ms</b>

6.3 The Input Data Format

**SEL 6/8="Low" or "NC" for 6 Bits LVDS**

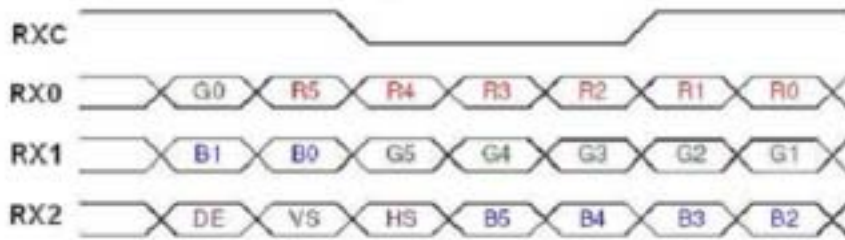

**SEL 6/8="High" for 8 Bits LVDS**



Note (1) R/G/B data 7: MSB, R/G/B data 0: LSB

Note (2) Please follow PSWG

Signal Name	Description	Remark
R7	Red Data 7 (MSB)	Red-pixel Data Each red pixel's brightness data consists of these 8 bits pixel data.
R6	Red Data 6	
R5	Red Data 5	
R4	Red Data 4	
R3	Red Data 3	
R2	Red Data 2	
R1	Red Data 1	
R0	Red Data 0 (LSB)	
G7	Green Data 7 (MSB)	Green-pixel Data Each green pixel's brightness data consists of these 8 bits pixel data.
G6	GreenData 6	
G5	GreenData 5	
G4	GreenData 4	
G3	GreenData 3	
G2	GreenData 2	
G1	GreenData 1	
G0	GreenData 0 (LSB)	
B7	Blue Data 7 (MSB)	Blue-pixel Data Each blue pixel's brightness data consists of these 8 bits pixel data.
B6	Blue Data 6	
B5	Blue Data 5	
B4	Blue Data 4	
B3	Blue Data 3	
B2	Blue Data 2	
B1	Blue Data 1	
B0	Blue Data 0 (LSB)	
RXCLKIN+ RXCLKIN-	LVDS Clock Input	
DE	Display Enable	
VS	Vertical Sync	
HS	Horizontal Sync	

## 7. OPTICAL CHARACTERISTICS

### 7.1 TEST CONDITIONS

Item	Symbol	Value	Unit
Ambient Temperature	Ta	25±2	°C
Ambient Humidity	Ha	50±10	%RH
Supply Voltage	V <sub>CC</sub>	3.3	V
Input Signal	According to typical value in "3. ELECTRICAL CHARACTERISTICS"		
Converter PWM duty		100%	

### 7.2 OPTICAL SPECIFICATIONS

The relative measurement methods of optical characteristics are shown in 7.2. The following items should be measured under the test conditions described in 7.1 and stable environment shown in Note (5).

Item	Symbol	Condition	Min.	Typ.	Max.	Unit	Note							
Color Chromaticity	Red	$\theta_x=0^\circ, \theta_y=0^\circ$ CS-1000	Typ - 0.05	0.601	Typ + 0.05	-	(1), (5)							
								Ry	0.340					
	Green							Gx	0.332					
								Gy	0.583					
	Blue							Bx	0.149					
								By	0.087					
	White							Wx	0.313					
								Wy	0.329					
	Center Luminance of White							L <sub>C</sub>		350	450	-	-	(4), (5)
	Contrast Ratio							CR		500	700	-	-	(2), (5)
Response Time	T <sub>R</sub>	$\theta_x=0^\circ, \theta_y=0^\circ$	-	5	10	ms	(3)							
	T <sub>F</sub>							11						
White Variation	$\delta W$	$\theta_x=0^\circ, \theta_y=0^\circ$	-	1.25	1.4	-	(5), (6)							
Viewing Angle	Horizontal	CR≥10	70	80	-	Deg.	(1), (5)							
								$\theta_{x-}$						
	Vertical							$\theta_{y+}$	60	70	-			
								$\theta_{y-}$	60	70	-			

Note (1) Definition of Viewing Angle ( $\theta_x, \theta_y$ ):

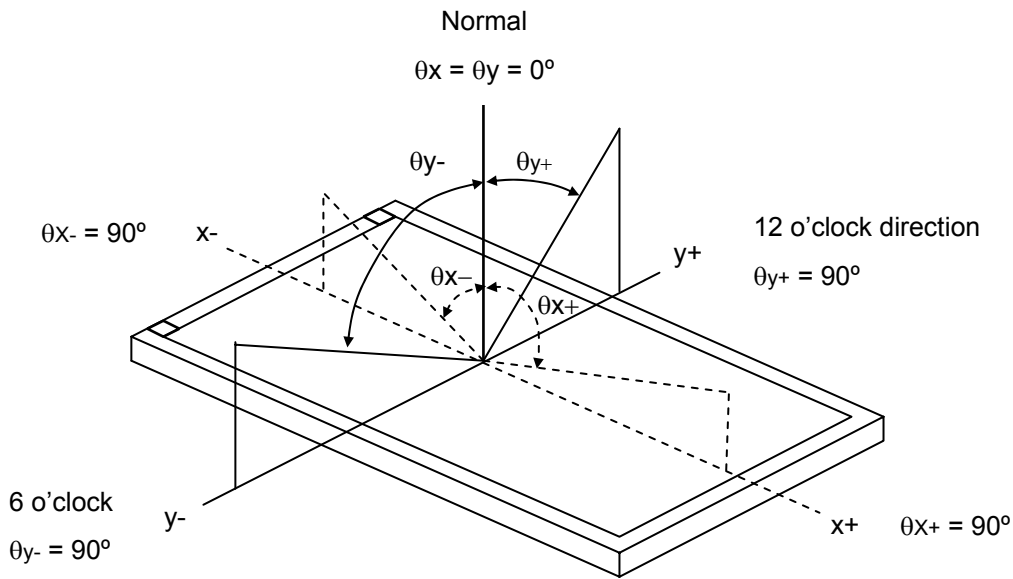

Note (2) Definition of Contrast Ratio (CR):

The contrast ratio can be calculated by the following expression.

$$\text{Contrast Ratio (CR)} = L_{63} / L_0$$

L63: Luminance of gray level 63

L 0: Luminance of gray level 0

$$CR = CR (5)$$

CR (X) is corresponding to the Contrast Ratio of the point X at Figure in Note (6).

Note (3) Definition of Response Time ( $T_R, T_F$ ) and measurement method:

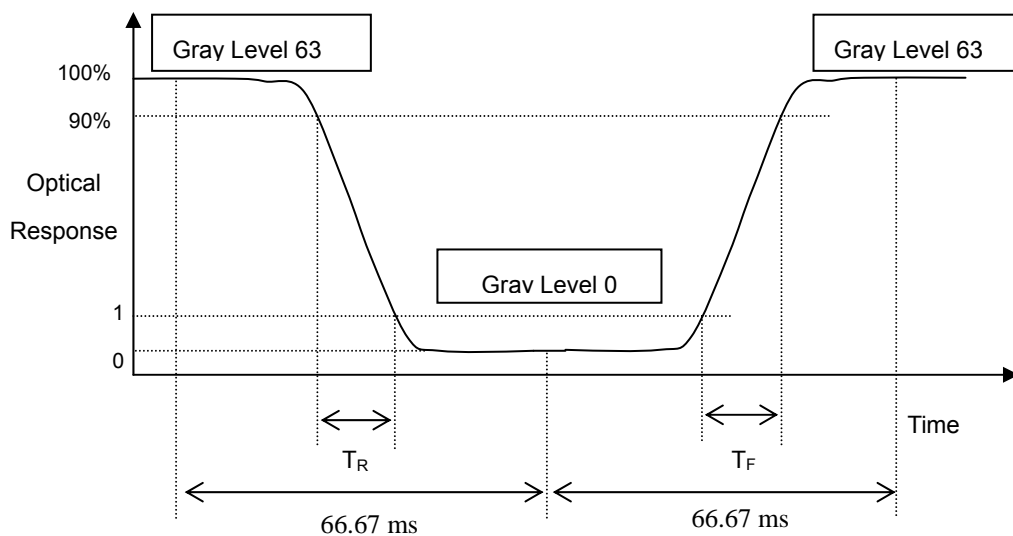

Note (4) Definition of Luminance of White ( $L_C$ ):

Measure the luminance of gray level 63 at center point

$$L_C = L(5)$$

$L(x)$  is corresponding to the luminance of the point X at Figure in Note (6).

Note (5) Measurement Setup:

The LCD module should be stabilized at given temperature for 20 minutes to avoid abrupt temperature change during measuring. In order to stabilize the luminance, the measurement should be executed after lighting Backlight for 20 minutes in a windless room.

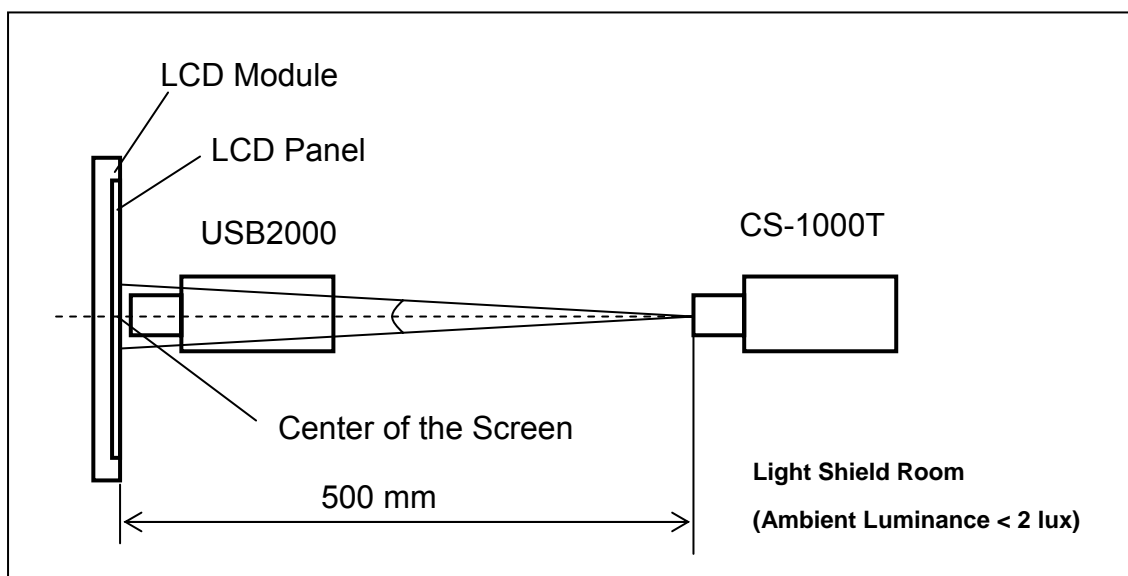

Note (6) Definition of White Variation ( $\delta W$ ):

Measure the luminance of gray level 63 at 5 points

$$\delta W = \frac{\text{Maximum [L (1), L (2), L (3), L (4), L (5)]}}{\text{Minimum [L (1), L (2), L (3), L (4), L (5)]}}$$

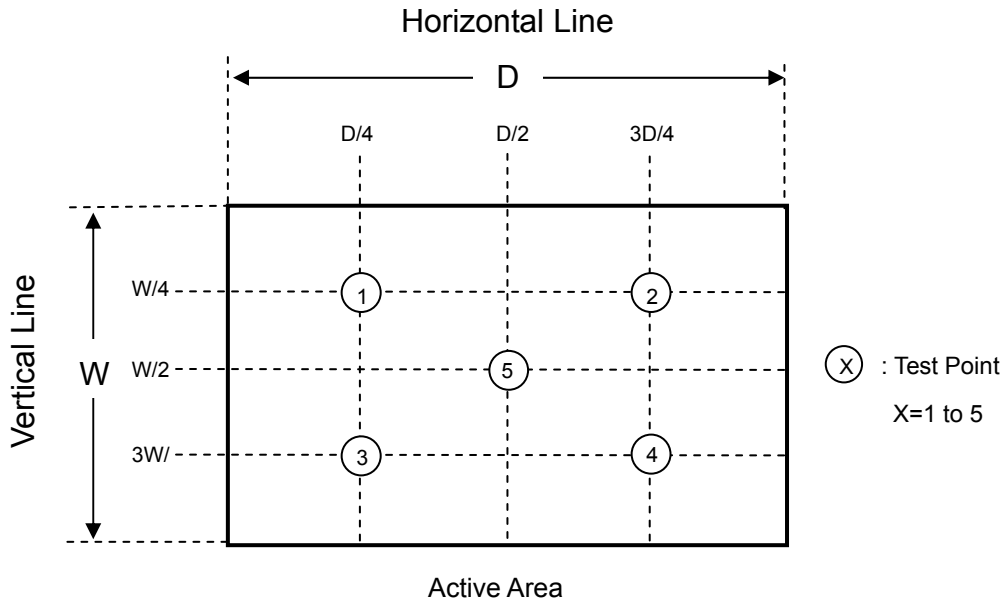

## 8. Reliability Test Criteria

Test Item	Test Condition	Note
High Temperature Storage Test	80°C, 240 hours	(1)(2)(4)
Low Temperature Storage Test	-30°C, 240 hours	
Thermal Shock Storage Test	-30°C, 0.5hour $\longleftrightarrow$ 80 , 0.5hour; 1hour/cycle,100cycles	
High Temperature Operation Test	70°C, 240 hours	
Low Temperature Operation Test	-30°C, 240 hours	
High Temperature & High Humidity Operation Test	60°C, 90%RH, 240hours	
Shock (Non-Operating)	50G, 2ms, half sine wave, 1 time for $\pm X, \pm Y, \pm Z$ .	
Vibration (Non-Operating)	1.5G, 10 ~ 300 Hz, 10min/cycle, 3 cycles each X, Y, Z	(3)(4)

Note (1) There should be no condensation on the surface of panel during test.

Note (2) Temperature of panel display surface area should be 80 °C Max.

Note (3) At testing Vibration and Shock, the fixture in holding the module has to be hard and rigid enough so that the module would not be twisted or bent by the fixture.

Note (4) In the standard conditions, there is no function failure issue occurred. All the cosmetic specification is judged before reliability test.

9. PACKAGING

9.1 PACKING SPECIFICATIONS

- (1) 13pcs LCD modules / 1 Box
- (2) Box dimensions: 465(L) X 362 (W) X 314 (H) mm
- (3) Weight: approximately 11 Kg (13 modules per box)

9.2 PACKING METHOD

(1) Carton Packing should have no failure in the following reliability test items.

Test Item	Test Conditions	Note
Vibration	ISTA STANDARD Random, Frequency Range: 2 – 200 Hz Top & Bottom: 30 minutes (+Z), 10 min (-Z), Right & Left: 10 minutes (X) Back & Forth 10 minutes (Y)	Non Operation
Dropping Test	1 Angle, 3 Edge, 6 Face, 61 cm	Non Operation

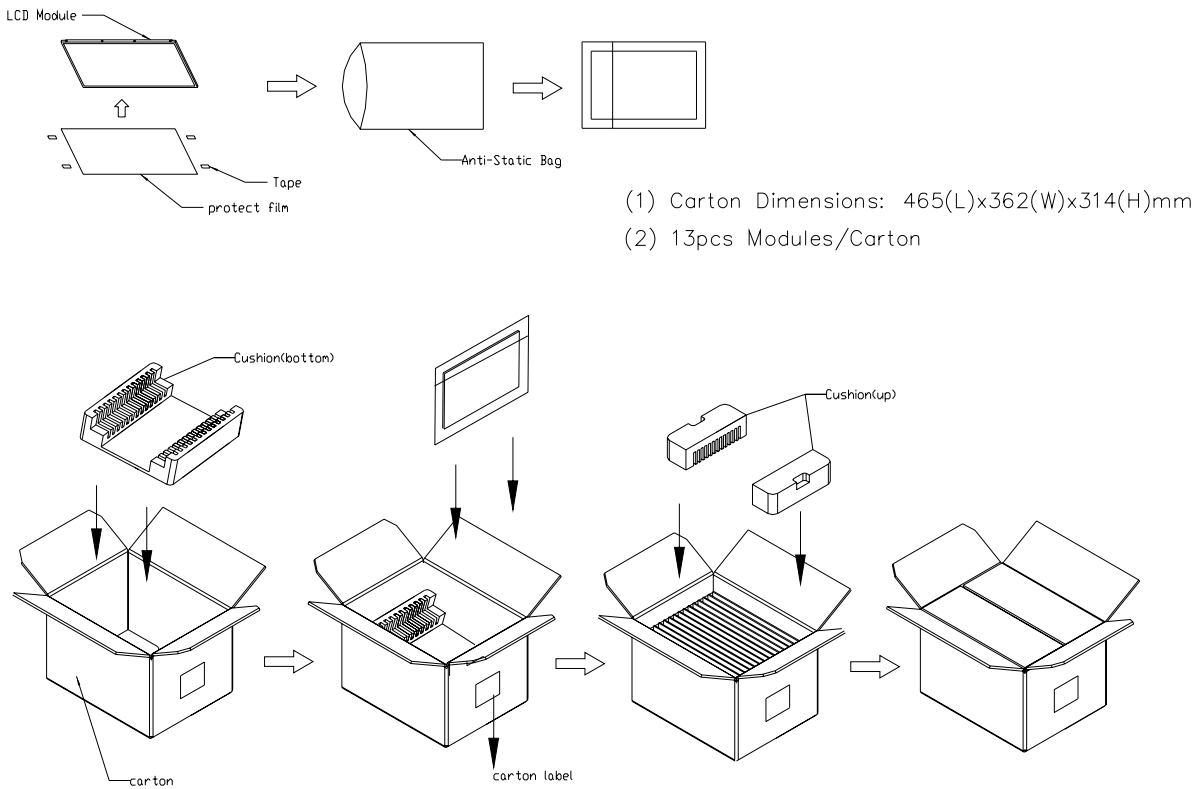
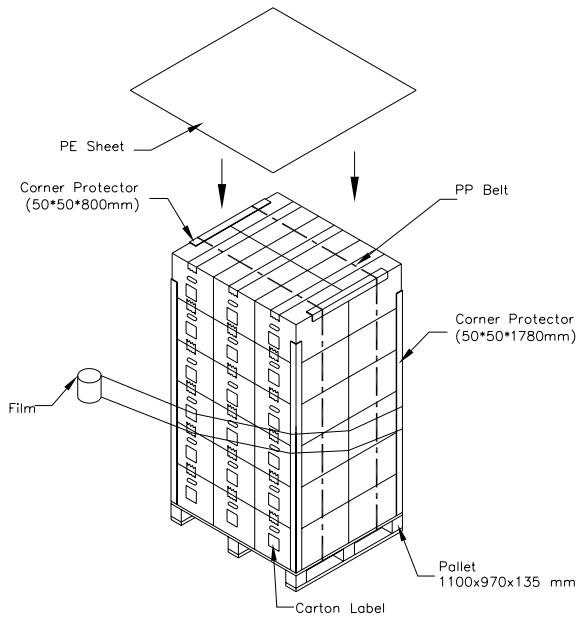

Figure. 9-1 Packing method

Sea / Land Transportation (40ft Container)



Air Transportation

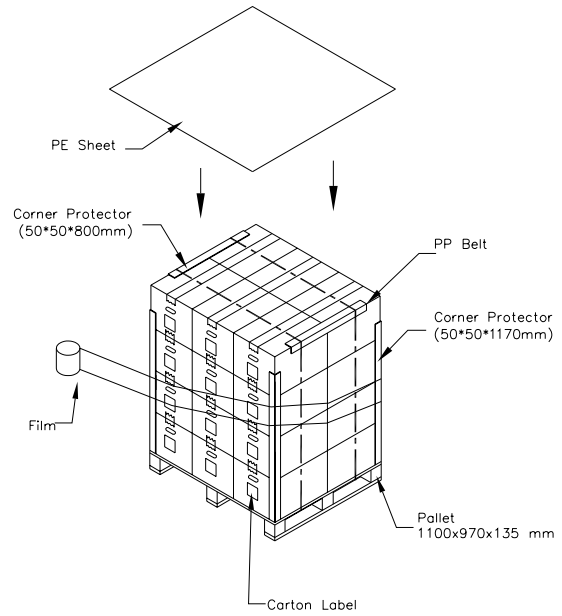
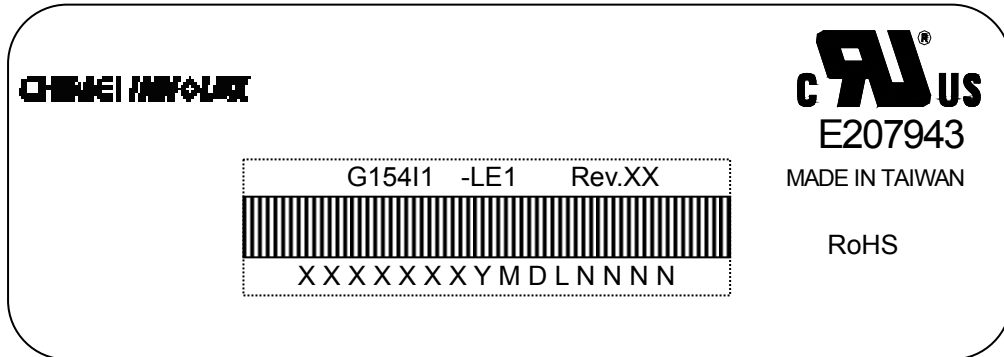

Figure. 9-2 Packing method

10. DEFINITION OF LABELS

10.1 CMO MODULE LABEL

The barcode nameplate is pasted on each module as illustration, and its definitions are as following explanation.



- (a) Model Name: G15411-LE1
- (b) Revision: Rev. XX, for example: A0, A1... B1, B2... or C1, C2...etc.
- (c) CMO barcode definition:

Serial ID: XX-XX-X-XX-YMD-L-NNNN

Code	Meaning	Description
XX	CMO internal use	-
XX	Revision	Cover all the change
X	CMO internal use	-
XX	CMO internal use	-
YMD	Year, month, day	Year: 2001=1, 2002=2, 2003=3, 2004=4... Month: 1~12=1, 2, 3, ~, 9, A, B, C Day: 1~31=1, 2, 3, ~, 9, A, B, C, ~, W, X, Y, exclude I, O, and U.
L	CMO internal use	-
NNNN	Serial number	Manufacturing sequence of product

## 11. PRECAUTIONS

### 11.1 ASSEMBLY AND HANDLING PRECAUTIONS

- (1) Do not apply rough force such as bending or twisting to the module during assembly.
- (2) To assemble or install module into user's system can be only in clean working areas. The dust and oil may cause electrical short or worsen the polarizer.
- (3) It's not permitted to have pressure or impulse on the module because the LCD panel and Backlight will be damaged.
- (4) Always follow the correct power sequence when LCD module is connecting and operating. This can prevent damage to the CMOS LSI chips during latch-up.
- (5) Do not pull the I/F connector in or out while the module is operating.
- (6) Do not disassemble the module.
- (7) Use a soft dry cloth without chemicals for cleaning, because the surface of polarizer is very soft and easily scratched.
- (8) It is dangerous that moisture come into or contacted the LCD module, because moisture may damage LCD module when it is operating.
- (9) High temperature or humidity may reduce the performance of module. Please store LCD module within the specified storage conditions.
- (10) When ambient temperature is lower than 10°C may reduce the display quality. For example, the response time will become slowly, and the starting voltage of CCFL will be higher than room temperature.
- (11) Do not keep same pattern in a long period of time. It may cause image sticking on LCD.

### 11.2 SAFETY PRECAUTIONS

- (1) Do not disassemble the module or insert anything into the Backlight unit.
- (2) If the liquid crystal material leaks from the panel, it should be kept away from the eyes or mouth. In case of contact with hands, skin or clothes, it has to be washed away thoroughly with soap.
- (3) After the module's end of life, it is not harmful in case of normal operation and storage.

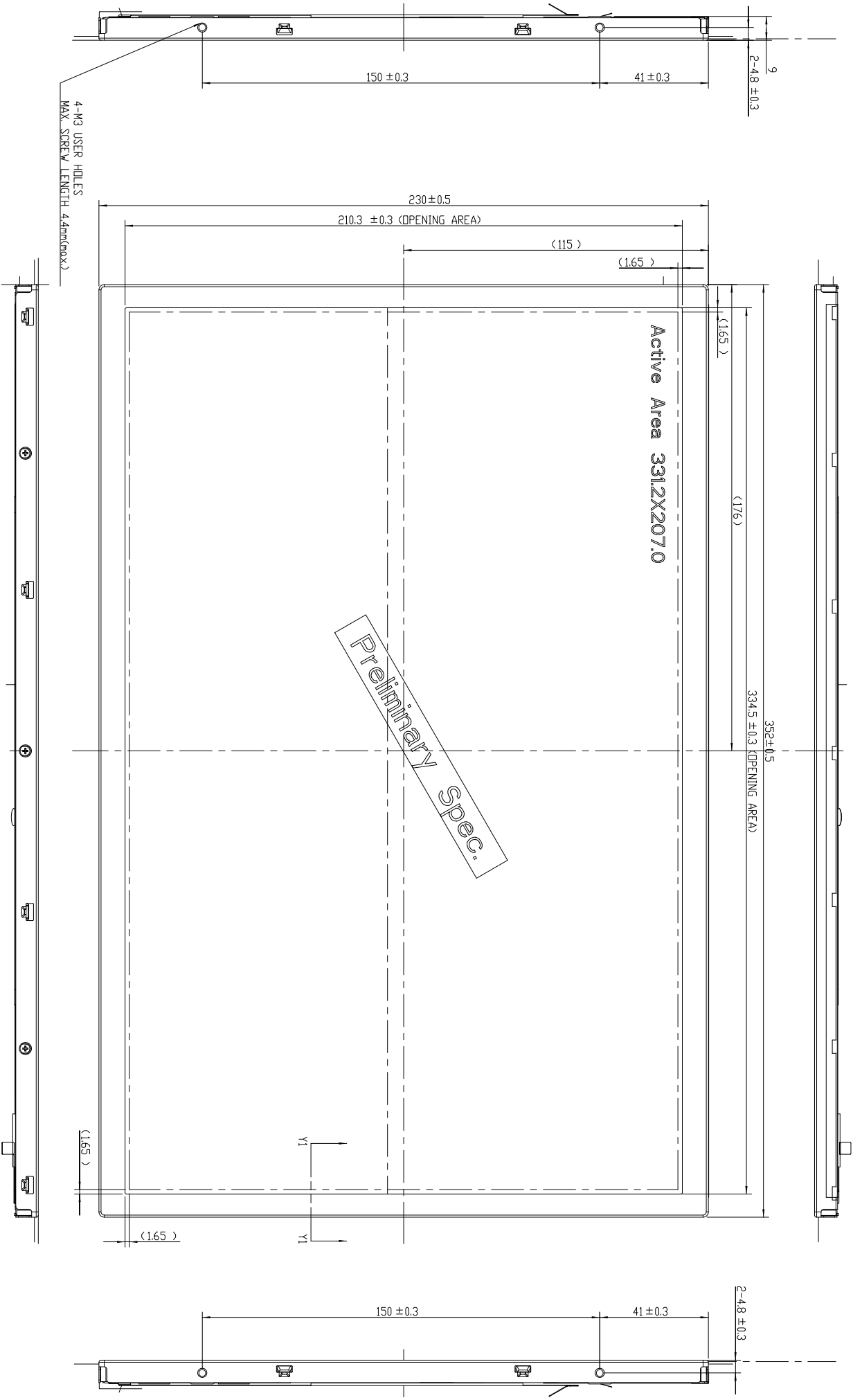

NOTES:  
 1. OUTLINE TOLERANCE: ±0.5mm.  
 2. I/F CONNECTOR SPEC: FT-SE20P-HFE (JAE) OR EQUIVALENT.  
 3. LAMP CONNECTOR: YEDNHD LOOKING TYPE 35001HS-02L OR EQUIVALENT.  
 4. SIDE MOUNT HOLE TDRQUE : 2kgf-cm (MAX.).

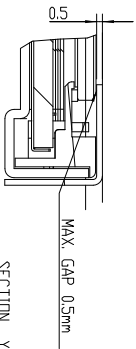

SECTION Y1-Y1  
 SCALE 3:1

Work	Description	Date	Changed_By	Approved_By	ECN No.	Remark
1		2				
2						
3						
4						
5						
6						
7						
8						

TITLE	ASSY MODULE GIS411 LEI	Drawing No.	GIS414021	2D REV/1.0
Approved	SY_F	Part No.	GF41E1901	3D REV/1.9*
Checked	CCY	Material	---	
Designer	Eason_Tseng	Date	05-Oct-2010	Scale
1/1	1/1	Unit/mm	1/1	Sheet 1 / 2
CHI MET		ALL RIGHTS RESERVED. COPYING PROHIBITED.		

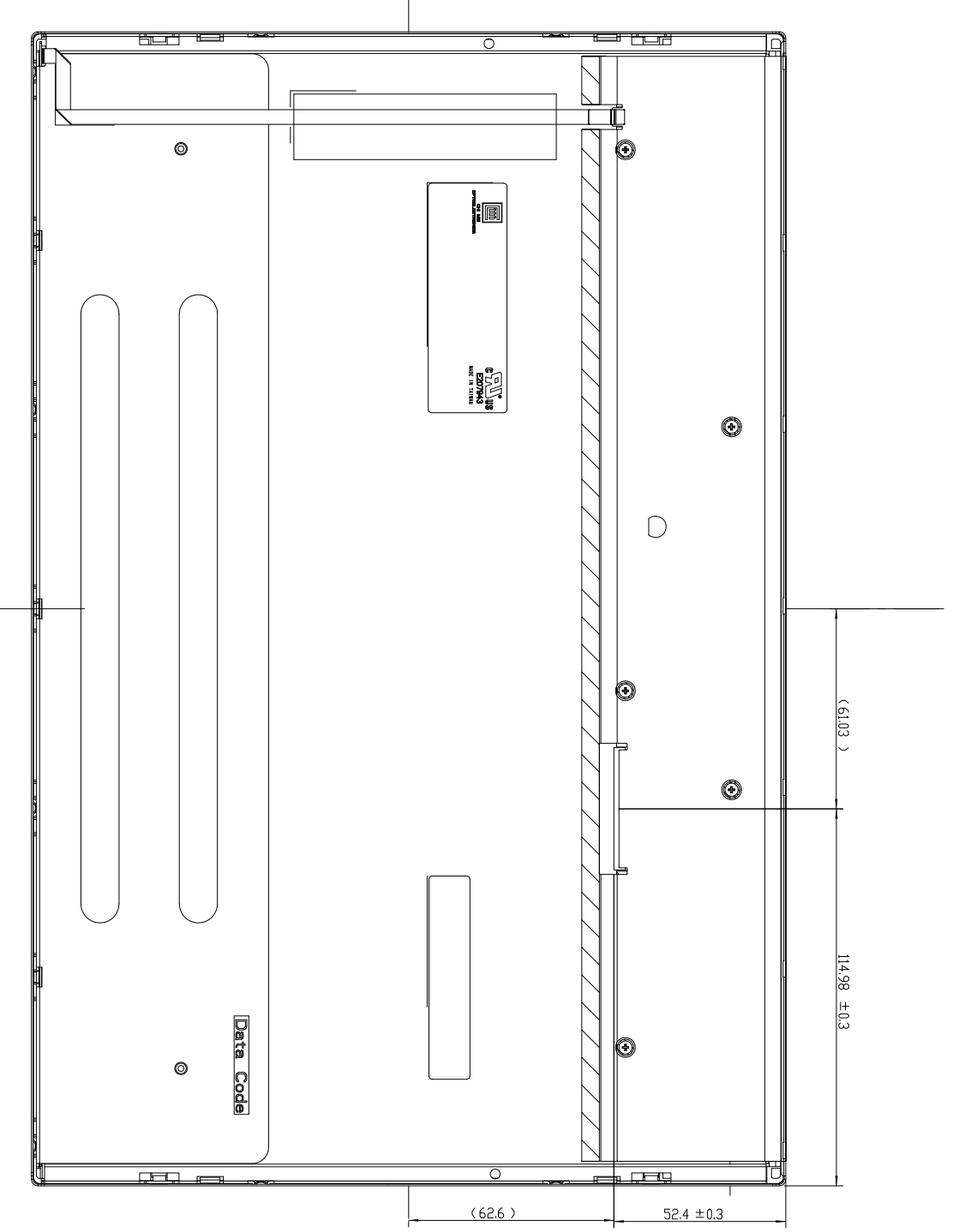

NOTES:  
 1. TOLERANCE: ±0.5mm.  
 2. 21/7 CONNECTOR SPEC: FT-SE20P-HFE (LAE) OR EQUIVALENT.  
 3. 3LAMP CONNECTOR: YEDNH\_LOCKING TYPE 3500HS-02L OR EQUIVALENT.  
 4. SIDE MOUNT HOLE TORQUE: ±2kgf-cm(MAX).

Work	1	2	3	4	5	6	7	8
Description								
Date								
Changed_By								
Approved_By								
ECN No.								
Remark								

TITLE	ASSY MODULE GIS411 LEI		ED REV/ 11
Approved	SY_LF	Drawing No.	GIS4141021
Checked	CCY	Part No.	GF41E1901
Designer	Eason_Tseong	Date	05-Oct-2010
Scale	1:1	Sheet	2 / 2
Units	mm	Scale	1:1

**CHI MET**  
 PERFELECTRONICS CORP.  
 ALL RIGHTS RESERVED. COPYING PROHIBITED.