

TFT LCD Approval Specification

MODEL NO.: V370H1 - L0A

Customer: _____

Approved by: _____

Note:

Liquid Crystal Display Division			
QRA Dept.	TVHD/PDD		
	DDIII	DDII	DDI
Approval	Approval	Approval	Approval
陳永一	李汪洋	藍文錦	林文聰

LCD TV Marketing and Project Management Dept.	
Product Manager	張俊儀

- CONTENTS -

REVISION HISTORY	3
1. GENERAL DESCRIPTION	5
1.1 OVERVIEW	
1.2 FEATURES	
1.3 APPLICATION	
1.4 GENERAL SPECIFICATIONS	
1.5 MECHANICAL SPECIFICATIONS	
2. ABSOLUTE MAXIMUM RATINGS	6
2.1 ABSOLUTE RATINGS OF ENVIRONMENT	
2.2 ELECTRICAL ABSOLUTE RATINGS	
2.2.1 TFT LCD MODULE	
2.2.2 BACKLIGHT INVERTER UNIT	
3. ELECTRICAL CHARACTERISTICS	8
3.1 TFT LCD MODULE	
3.2 BACKLIGHT UNIT	
3.2.1 CCFL CHARACTERISTICS	
3.2.2 INVERTER CHARACTERISTICS	
3.2.3 INVERTER INTERFACE CHARACTERISTIC	
4. BLOCK DIAGRAM	14
4.1 TFT LCD MODULE	
5. INTERFACE PIN CONNECTION	15
5.1 TFT LCD MODULE	
5.2 BACKLIGHT UNIT	
5.3 INVERTER UNIT	
5.4 BLOCK DIAGRAM OF INTERFACE	
5.5 LVDS INTERFACE	
5.6 COLOR DATA INPUT ASSIGNMENT	
6. INTERFACE TIMING	22
6.1 INPUT SIGNAL TIMING SPECIFICATIONS	
6.2 POWER ON/OFF SEQUENCE	
7. OPTICAL CHARACTERISTICS	25
7.1 TEST CONDITIONS	
7.2 OPTICAL SPECIFICATIONS	
8. DEFINITION OF LABELS	29
8.1 CMO MODULE LABEL	
9. PACKAGING	30
9.1 PACKING SPECIFICATIONS	
9.2 PACKING METHOD	
10. PRECAUTIONS	32
10.1 ASSEMBLY AND HANDLING PRECAUTIONS	
10.2 SAFETY PRECAUTIONS	
11. MECHANICAL CHARACTERISTIC	33

REVISION HISTORY

Version	Date	Page (New)	Section	Description
Ver 1.0 --- Ver 1.1	Oct 03,'05 --- Dec.12,05	All --- P.7	All --- 3.1	Preliminary Specification was first issued. --- Power Supply Current(at Vcc=18) White(typ.)1.0A ,black(typ.)0.5A; Power Supply Current (at Vcc =12) White(typ.)=1.5A,black(typ.)0.7 A. Note:(1)The module should be always operated within either the 12V or 18V range.
		P9	3.2.1 3.2.2	CCFL CHARACTERISTICS ,lamp current 5.2mA INVERTER CHARACTERISTICS($I_L = 5.2mA$) Power consumption typ.151.2 Power supply current typ. 6.3
		P13.	4.1	TFT_LCD Module(CN3: S2B-ZR-SM3A-TF (JST) or equivalent
		P14.	5.1	CNF1 Connector Pin Assignment :FI-RE51S-HF (JAE)
		P.15	5.3	CN4-CN13 (Housing): BHR-04VS-1
		P.16	5.4	CN3(Header) S2B-ZR-SM3A-TF (JST)
		P24	7.2	OPTICAL SPECIFICATIONS
		P32-34	11	MECHANICAL CHARACTERISTIC
Ver 1.2	Feb,13,'06	5 7 9 14-15 24 32-34	2.1 3.1 3.2.1 5.1 7.2 11	Note(2) $V_{RP} = 400$ $I_{RUSH} = 4.0$ $I_{CC}(Typ.)=1.0A(white), I_{CC}(Typ.)=0.5(Black), I_{CC}(Typ.)=0.8(Vertical Stripe)$ At Vcc=18V; $I_{CC}(Typ.)=1.5A(white), I_{CC}(Typ.)=0.7(Black), I_{CC}(Typ.)=1.2(Ve$ rtical Stripe) At Vcc=12V. Lamp Voltage(typ.)1310 CNF1 Connector Pin Assignment. $L_C(Typ.)=500, L_{AVE}(Typ.)=450$ Note(2),Note(5) Mechanical Characteristic
Ver 2.0	April.10,06'	7 9 24 28 32-34	3.1 3.2.1 3.2.2 7.2 8.1 11	Rush Current , Power Supply Current(at Vcc = 18); Power Supply Current(at Vcc = 12) Lamp Starting Voltage Power consumption; Power Supply Current; Oscillating Frequency Contrast Ratio(Min) 900; Center Luminance of White 400Average Luminance of white 350 Module label MECHANICAL CHARACTERISTIC
Ver 2.1	April 20,06'	9 11-12	3.2.1 3.2.2 3.2.3	Lamp Starting Voltage : $V_S = 2380(Ta = 0\text{ }^\circ\text{C}), V_S = 1700(Ta = 25\text{ }^\circ\text{C})$ Backlight Turn on Voltage : $V_{BS} = 2380(Ta = 0\text{ }^\circ\text{C}), V_{BS} = 1700(Ta = 25\text{ }^\circ\text{C})$ INVERTER INTERFACE CHARACTERISTICS External PWM Control Voltage., PWM Signal Rising Time, PWM Signal Falling Time,Note(1)

		13	4.1	BLOCK DIAGRAM _4.1 TFT LCD MODULE
		24	7.1	Oscillating Frequency (Inverter)

1. GENERAL DESCRIPTION

1.1 OVERVIEW

V370H1-L0A is a 37" thin-film-transistor liquid-crystal (TFT-LCD) module with 20-CCFL Backlight unit and 2ch-LVDS interface. This module supports 1920 x 1080 HDTV format and can display true 16.7M colors (8-bit/color). The inverter module for backlight is built-in.

1.2 FEATURES

- Ultra wide viewing angle – Super MVA technology
- High brightness (500 nits)
- High contrast ratio 1200:1
- Fast response time (Gray to gray average 6.5ms)
- High color saturation (NTSC 75%)
- HD (1920 x 1080 pixels) resolution
- DE (Data Enable) only mode
- LVDS (Low Voltage Differential Signaling) interface

1.3 APPLICATION

- Standard Living Room TVs.
- Public Display Application.
- Home Theater Application.
- MFM Application.

1.4 GENERAL SPECIFICATIONS

Item	Specification	Unit	Note
Active Area	820.8 (H) x 461.7 (V) (37.07" diagonal)	mm	(1)
Bezel Opening Area	828.8 (H) x 470.9 (V)	mm	
Driver Element	a-si TFT active matrix	-	-
Pixel Number	1920x R.G.B. x 1080	pixel	-
Pixel Pitch(Sub Pixel)	0.1425 (H) x 0.4275 (V)	mm	-
Pixel Arrangement	RGB vertical stripe	-	-
Display Colors	16.7M	color	-
Display Operation Mode	Transmissive mode / Normally black	-	-
Surface Treatment	Anti-Glare coating (Haze 25%) Hard coating (3H)	-	(2)

Note (1) Please refer to the attached drawings in chapter 9 for more information about the front and back outlines.

Note (2) The spec of the surface treatment is temporarily for this phase. CMO reserves the rights to change this feature.

1.5 MECHANICAL SPECIFICATIONS

Item	Min.	Typ.	Max.	Unit	Note	
Module Size	Horizontal(H)	873.3	874	874.7	mm	
	Vertical(V)	514	514.6	515.2	mm	
	Depth(D)	43.34	44.34	45.34	mm	To PCB cover
	Depth(D)	50.34	51.84	53.34	mm	To inverter cover
Weight	9800	10000	10200	g		

2. ABSOLUTE MAXIMUM RATINGS

2.1 ABSOLUTE RATINGS OF ENVIRONMENT

Item	Symbol	Value		Unit	Note
		Min.	Max.		
Storage Temperature	T _{ST}	-20	+60	°C	(1)
Operating Ambient Temperature	T _{OP}	0	50	°C	(1), (2)
Shock (Non-Operating)	S _{NOP}	-	50	G	(3), (5)
Vibration (Non-Operating)	V _{NOP}	-	1.0	G	(4), (5)

Note (1) Temperature and relative humidity range is shown in the figure below.

(a) 90 %RH Max. (Ta ≤ 40 °C).

(b) Wet-bulb temperature should be 39 °C Max. (Ta > 40 °C).

(c) No condensation.

Note (2) The maximum operating temperature is based on the test condition that the surface temperature of display area is less than or equal to 65 °C with LCD module alone in a temperature controlled chamber. Thermal management should be considered in your product design to prevent the surface temperature of display area from being over 65 °C. The range of operating temperature may degrade in case of improper thermal management in your product design.

Note (3) 11 ms, half sine wave, 1 time for ± X, ± Y, ± Z.

Note (4) 10 ~ 200 Hz, 10 min, 1 time each X, Y, Z

Note (5) At testing Vibration and Shock, the fixture in holding the module has to be hard and rigid enough so that the module would not be twisted or bent by the fixture. The module would not be twisted or bent by the fixture.

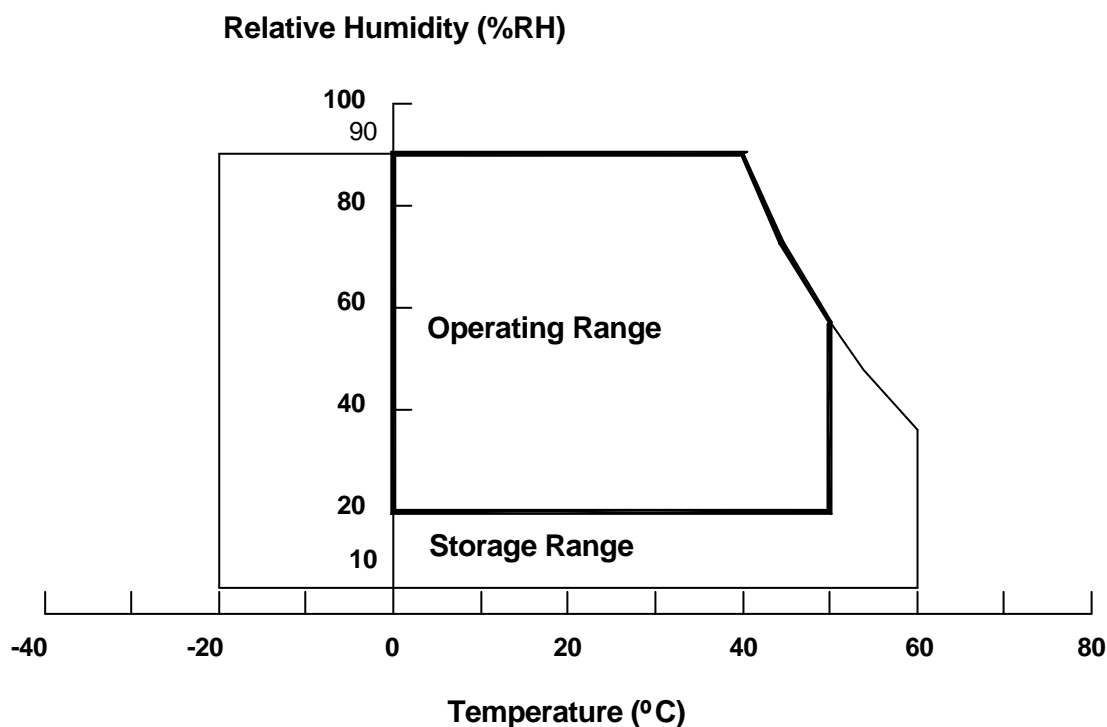

2.2 ELECTRICAL ABSOLUTE RATINGS

2.2.1 TFT LCD MODULE

Item	Symbol	Value		Unit	Note
		Min.	Max.		
Power Supply Voltage	V _{CC}	-0.3	20	V	(1)
Logic Input Voltage	V _{IN}	-0.3	3.6	V	

Note: (1) Permanent damage to the device may occur if maximum values are exceeded. Functional operation should be restricted to the conditions described under normal operating conditions.

2.2.2 BACKLIGHT UNIT

Item	Symbol	Value		Unit	Note
		Min.	Max.		
Lamp Voltage	V _W	-	3000	V _{RMS}	
Power Supply Voltage	V _{BL}	0	30	V	(1)
Control Signal Level	-	-0.3	7	V	(1), (3)

Note (1) Permanent damage to the device may occur if maximum values are exceeded. Function operation should be restricted to the conditions described under Normal Operating Conditions.

Note (2) No moisture condensation or freezing.

Note (3) The control signals includes On/Off Control, Internal PWM Control

3. ELECTRICAL CHARACTERISTICS

3.1 TFT LCD MODULE

Ta = 25 ± 2 °C

Parameter		Symbol	Value			Unit	Note
			Min.	Typ.	Max.		
Power Supply Voltage		V _{CC}	10.8 16.2	12 18	13.2 19.8	V	(1)
Power Supply Ripple Voltage		V _{RP}	-	-	400	mV	
Rush Current		I _{RUSH}	-	-	3.0	A	(2)
Power Supply Current (at V _{CC} = 18)	White	I _{CC}	-	0.8	-	A	(3)
	Black		-	0.36	-	A	
	Vertical Stripe		-	0.6	-	A	
Power Supply Current (at V _{CC} = 12)	White	I _{CC}	-	1.2	-	A	
	Black		-	0.5	-	A	
	Vertical Stripe		-	0.9	-	A	
LVDS Interface	Differential Input High Threshold Voltage	V _{LVTH}	-	-	+100	mV	
	Differential Input Low Threshold Voltage	V _{LVTL}	-100	-	-	mV	
	Common Input Voltage	V _{LVC}	1.125	1.25	1.375	V	
	Terminating Resistor	R _T	-	100	-	ohm	
CMOS interface	Input High Threshold Voltage	V _{IH}	2.7	-	3.3	V	
	Input Low Threshold Voltage	V _{IL}	0	-	0.7	V	

Note: (1)The module should be always operated within either the 12V or 18V range.

(2) Measurement condition:

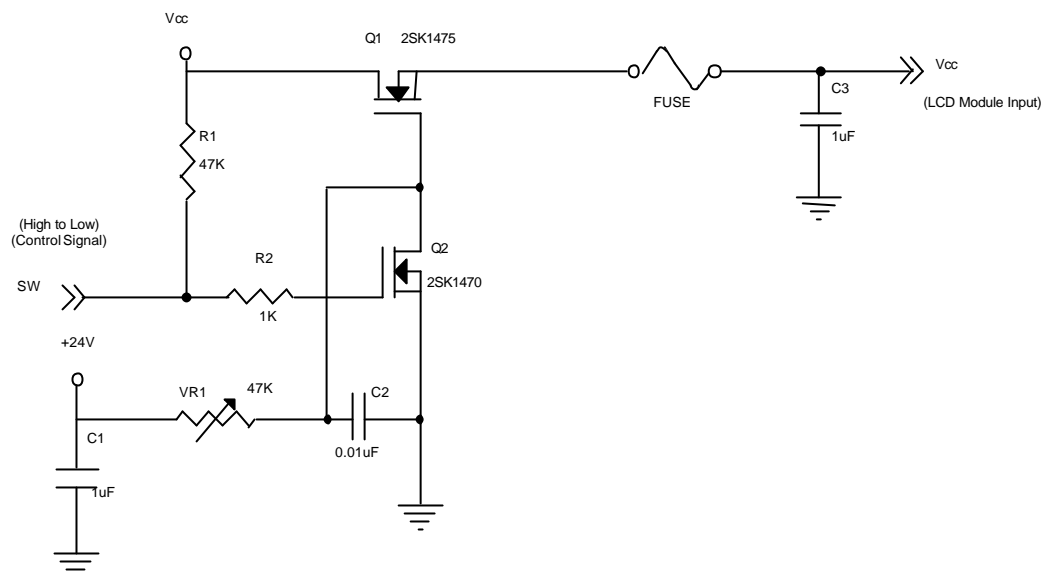

Vcc rising time is 470us

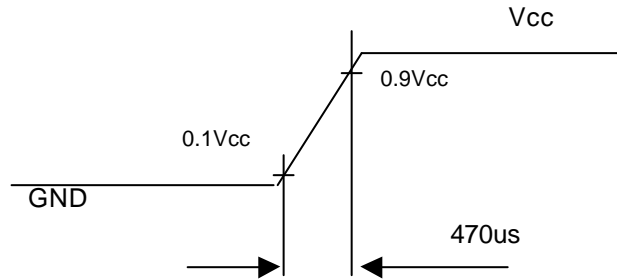

Note (3) The specified power supply current is under the conditions at $V_{cc} = 18 / 12V$, $T_a = 25 \pm 2 \text{ }^\circ\text{C}$, $f_f = 60$ Hz, whereas a power dissipation check pattern below is displayed.

a. White Pattern

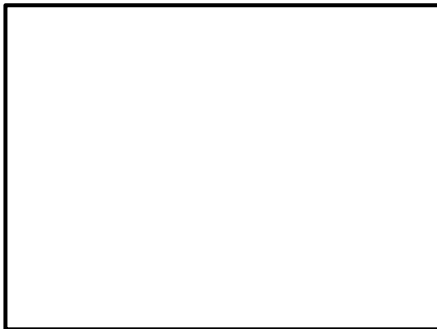

Active Area

b. Black Pattern



Active Area

c. Vertical Stripe Pattern

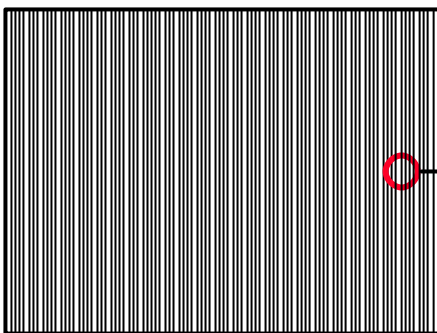

Active Area

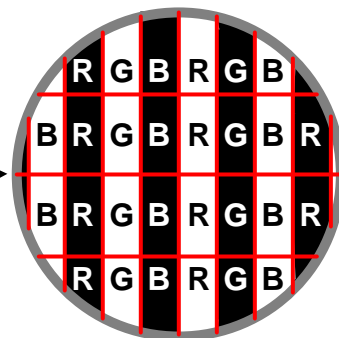

3.2 BACKLIGHT UNIT

3.2.1 CCFL (Cold Cathode Fluorescent Lamp) CHARACTERISTICS (Ta=25±2)

Parameter	Symbol	Value			Unit	Note
		Min.	Typ.	Max.		
Lamp Voltage	V _W	-	1310	-	V _{RMS}	I _L = 5.2mA
Lamp Current	I _L	4.7	5.2	5.7	mA _{RMS}	(1)
Lamp Starting Voltage	V _S	-	-	2380	V _{RMS}	(2), Ta = 0 °C
		-	-	1700	V _{RMS}	(2), Ta = 25 °C
Operating Frequency	F _o	40	-	70	KHz	(3)
Lamp Life Time	L _{BL}	50,000	60,000	-	Hrs	(4)

3.2.2 INVERTER CHARACTERISTICS (Ta =25±2)

Parameter	Symbol	Value			Unit	Note
		Min.	Typ.	Max.		
Power consumption	P _{BL}	-	156	-	W	(5), I _L = 5.2mA
Power Supply Voltage	V _{BL}	22.8	24	25.2	V _{DC}	
Power Supply Current	I _{BL}	-	6.5	-	A	Non Dimming
Input Ripple Noise	-	-	-	500	mVp-p	V _{BL} =22.8V
Backlight Turn on Voltage	V _{BS}	2380	-	-	V _{RMS}	Ta = 0 °C
	-	1700	-	-	V _{RMS}	Ta = 25 °C
Oscillating Frequency	F _W	47	50	53	kHz	
Dimming frequency	F _B	150	160	170	Hz	
Minimum Duty Ratio	D _{MIN}	-	20	-	%	

Note (1) Lamp current is measured by utilizing high frequency current meters as shown below:

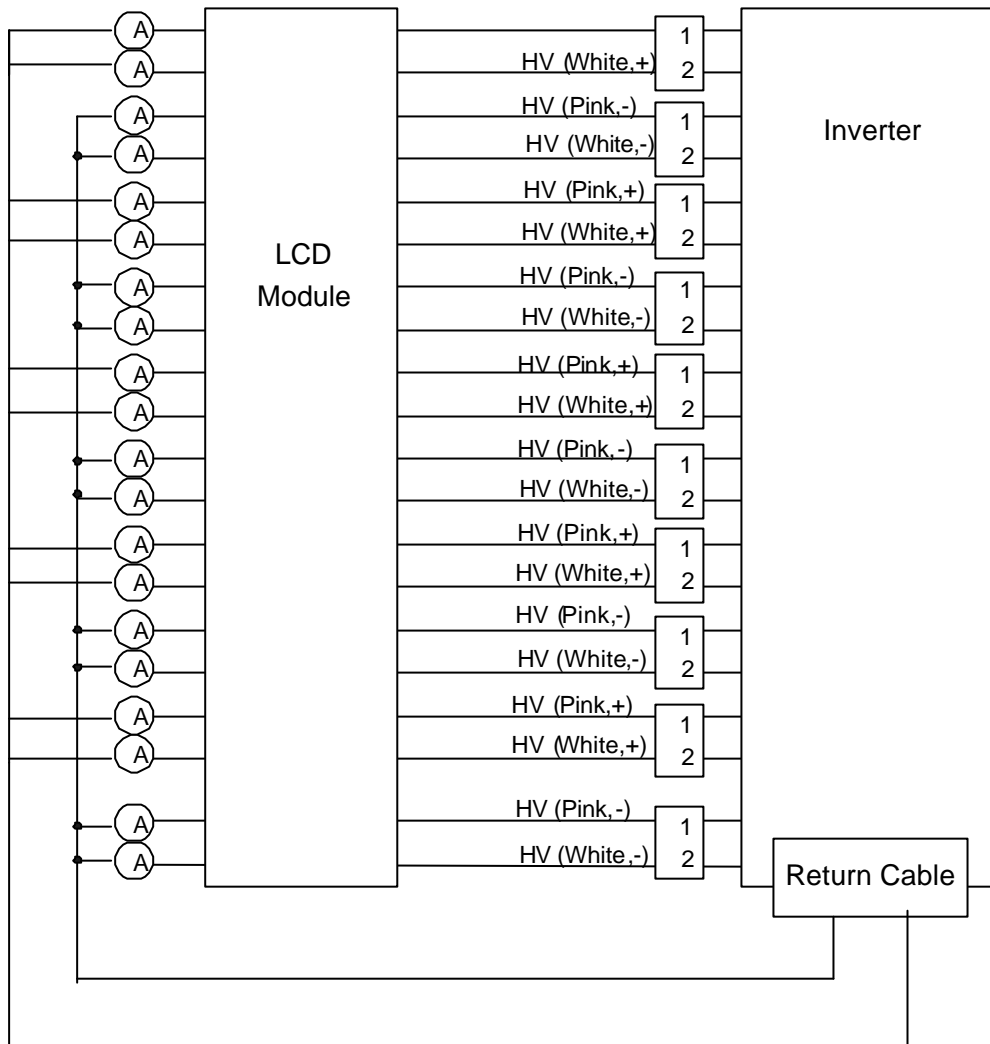

Note (2) The lamp starting voltage V_S should be applied to the lamp for more than 1 second under starting up duration. Otherwise the lamp could not be lighted on completely.

Note (3) The lamp frequency may produce interference with horizontal synchronous frequency from the display, and this may cause line flow on the display. In order to avoid interference, the lamp frequency should be detached from the horizontal synchronous frequency and its harmonics as far as possible.

Note (4) The life time of a lamp is defined as when the brightness is larger than 50% of its original value and the effective discharge length is longer than 80% of its original length (Effective discharge length is defined as an area that has equal to or more than 70% brightness compared to the brightness at the center point.) as the time in which it continues to operate under the condition
 $T_a = 25 \pm 2$ and $I_L = 4.7 \sim 5.7 \text{mA}_{\text{RMS}}$.

Note (5) The power supply capacity should be higher than the total inverter power consumption P_{BL} . Since the pulse width modulation (PWM) mode was applied for backlight dimming, the driving current

changed as PWM duty on and off. The transient response of the power supply should be considered for the changing loading when inverter dimming.

3.2.3 INVERTER INTERFACE CHARACTERISTICS

Parameter	Symbol	Test Condition	Value			Unit	Note	
			Min.	Typ.	Max.			
On/Off Control Voltage	ON	V_{BLON}	-	2.0	-	5.0	V	
	OFF		-	0	-	0.8	V	
Internal PWM Control Voltage	MAX	V_{IPWM}	-	-	-	3.0	V	maximum duty ratio
	MIN			-	0	-	V	minimum duty ratio
External PWM Control Voltage.	HI	V_{EPWM}	$V_{SEL} = H$	2.0	-	5.0	V	duty on
	LO			0	-	0.8	V	duty off
Control Signal Rising Time	T_r	-	-	-	100	ms		
Control Signal Falling Time	T_f	-	-	-	100	ms		
PWM Signal Rising Time	T_{PWMR}	-	-	-	50	us		
PWM Signal Falling Time	T_{PWMF}	-	-	-	50	us		
Input impedance	R_{IN}	-	1	-	-	M		
BLON Delay Time1	T_{on1}	-	1	-	-	ms		
BLON Off Time1	T_{off1}	-	1	-	-	ms		

Note (1) The SEL signal should be valid before backlight turns on by BLON signal. It is inhibited to change the internal/external PWM selection (SEL) during backlight turn on period.

Note (2) The power sequence and control signal timing are shown in the following figure.

Note (3) The power sequence and control signal timing must follow the figure below. For a certain reason, the inverter has a possibility to be damaged with wrong power sequence and control signal timing.

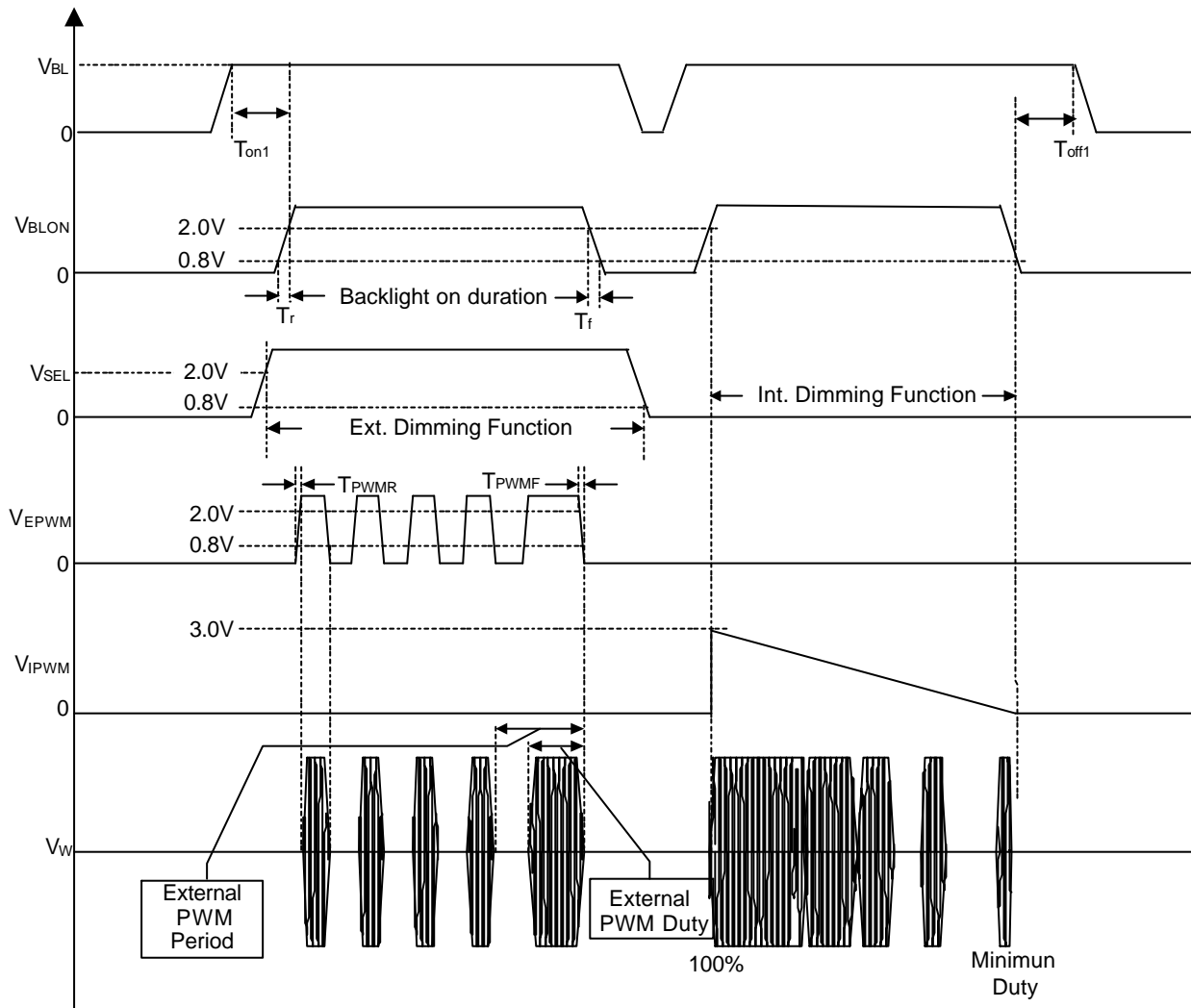

4. BLOCK DIAGRAM

4.1 TFT LCD MODULE

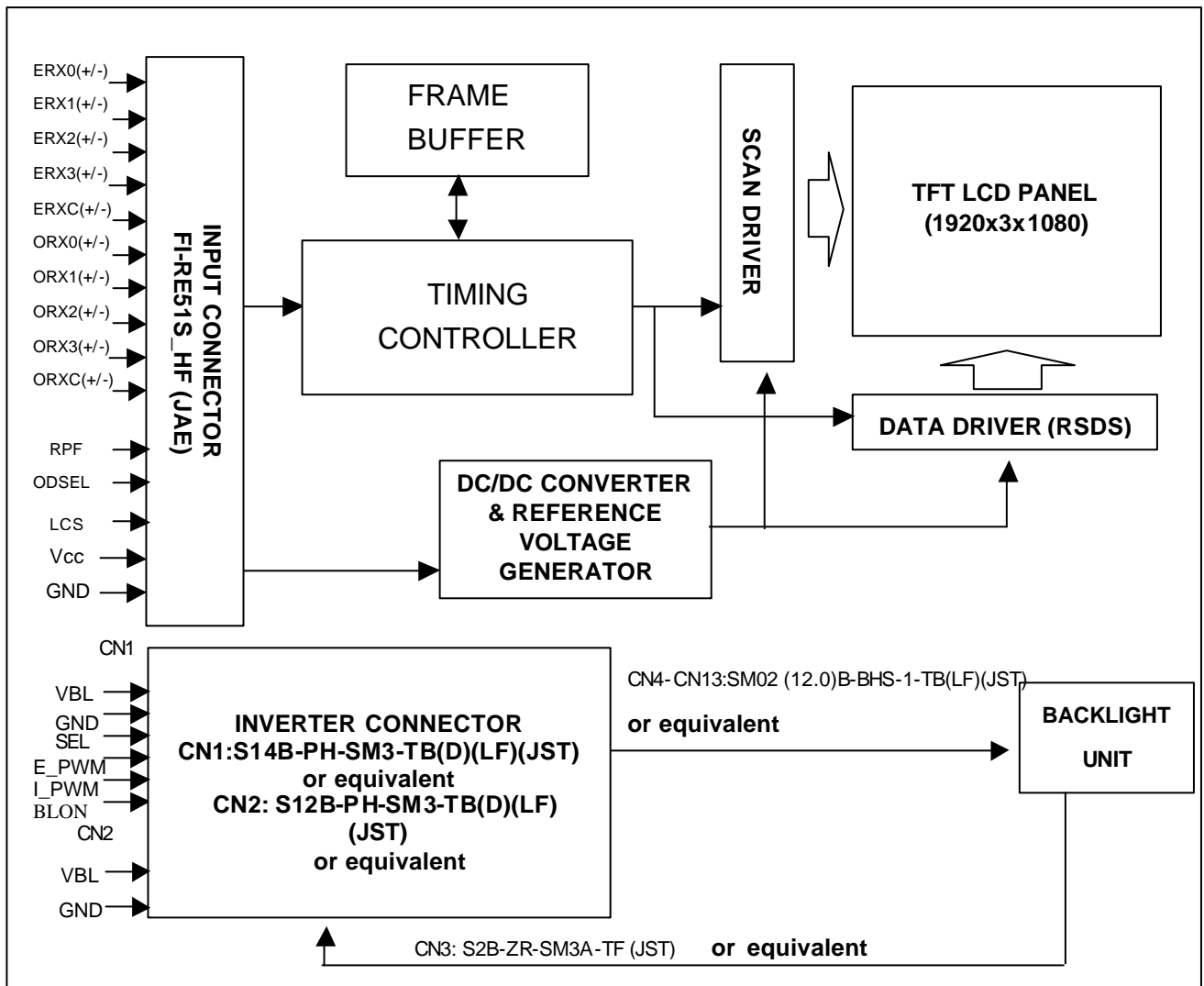

5. V370H1-L0A LCD INPUT TERMINAL PIN ASSIGNMENT

5.1 TFT LCD MODULE LVDS input

CNF1 Connector Pin Assignment : F1RE51S-HF (JAE)

Pin	Name	Description	Note
1	GND	Ground	
2	N.C.	No Connection	(2)
3	N.C.	No Connection	(2)
4	N.C.	No Connection	(2)
5	N.C.	No Connection	(2)
6	N.C.	No Connection	(2)
7	NC	No Connection	(2)
8	RPF	Display Rotation	(3)
9	ODSEL	Overdrive Lookup Table Selection	(4)
10	LCS	Low color shift	(5)
11	GND	Ground	
12	ORX0-	Odd pixel, Negative LVDS differential data input. Channel 0	
13	ORX0+	Odd pixel, Positive LVDS differential data input. Channel 0	
14	ORX1-	Odd pixel, Negative LVDS differential data input. Channel 1	
15	ORX1+	Odd pixel, Positive LVDS differential data input. Channel 1	
16	ORX2-	Odd pixel, Negative LVDS differential data input. Channel 2	
17	ORX2+	Odd pixel, Positive LVDS differential data input. Channel 2	
18	GND	Ground	
19	OCLK-	Odd pixel, Negative LVDS differential clock input.	
20	OCLK+	Odd pixel, Positive LVDS differential clock input.	
21	GND	Ground	
22	ORX3-	Odd pixel, Negative LVDS differential data input. Channel 3	
23	ORX3+	Odd pixel, Positive LVDS differential data input. Channel 3	
24	N.C.	No Connection	(2)
25	N.C.	No Connection	(2)
26	N.C.	No Connection	(2)
27	N.C.	No Connection	(2)
28	ERX0-	Even pixel, Negative LVDS differential data input. Channel 0	
29	ERX0+	Even pixel, Positive LVDS differential data input. Channel 0	
30	ERX1-	Even pixel, Negative LVDS differential data input. Channel 1	
31	ERX1+	Even pixel, Positive LVDS differential data input. Channel 1	

32	ERX2-	Even pixel, Negative LVDS differential data input. Channel 2	
33	ERX2+	Even pixel, Positive LVDS differential data input. Channel 2	
34	GND	Ground	
35	ECLK-	Even pixel, Negative LVDS differential clock input.	
36	ECLK+	Even pixel, Positive LVDS differential clock input.	
37	GND	Ground	
38	ERX3-	Even pixel, Negative LVDS differential data input. Channel 3	
39	ERX3+	Even pixel, Positive LVDS differential data input. Channel 3	
40	N.C.	No Connection	(2)
41	N.C.	No Connection	(2)
42	N.C.	No Connection	(2)
43	N.C.	No Connection	(2)
44	GND	Ground	
45	GND	Ground	
46	GND	Ground	
47	GND	Ground	
48	VCC	Power input	
49	VCC	Power input	
50	VCC	Power input	
51	VCC	Power input	

Note (1) Connector part No: FI-RE51S-HF (JAE) or equivalent.

Note (2) Please be reserved to open.

Note (3) Low: normal display (default), High: display with 180 degree rotation

Note (4) Overdrive lookup table selection. The overdrive lookup table should be selected in accordance to the frame rate to optimize image quality.

ODSEL	Note
L	Lookup table was optimized for 60 Hz frame rate.
H	Lookup table was optimized for 50 Hz frame rate.

Note (5) Low: normal display (default), High: Low Color Shift function enable.

5.2 BACKLIGHT UNIT

The pin configuration for the housing and the leader wire is shown in the table below.

CN4-CN13 (Housing): BHR-04VS-1

Pin	Name	Description	Wire Color
1	HV	High Voltage	Pink
2	HV	High Voltage	White

Note (1) The backlight interface housing for high voltage side is a model BHR-04VS-1, manufactured by JST.

The mating header on inverter part number is SM02(12.0)B-BHS-1-TB.

5.3 INVERTER UNIT

CN1 (Header):S14B-PH-SM3-TB (D)(LF)(JST) or equivalent.

Pin No.	Symbol	Description
1	VBL	+24V _{DC} power input
2		
3		
4		
5		
6	GND	GND
7		
8		
9		
10		
11	SEL	Internal/external PWM selection High : external dimming Low : internal dimming
12	E_PWM	External PWM control signal E_PWM should be connected to ground when internal PWM was selected (SEL = Low).
13	I_PWM	Internal PWM Control Signal I_PWM should be connected to ground when external PWM was selected (SEL = High).
14	BLON	Backlight on/off control

CN2 (Header): S12B-PH-SM3-TB (D)(LF)(JST) or equivalent.

Pin No.	Symbol	Description
1	VBL	+24V _{DC} power input
2		
3		
4		
5		
6	GND	GND
7		
8		
9		
10		
11	NC	NC
12	NC	NC

CN3 (Header): S2B-ZR-SM3A-TF (JST) or equivalent

Pin No.	Symbol	Description
1	CCFL Cold	CFL Low voltage
2	CCFL Cold	CFL Low voltage

CN4-CN13 (Header): SM02(12.0)B-BHS-1-TB (LF)(JST) or equivalent

Pin No.	Symbol	Description
1	CCFL HOT	CCFL high voltage
2	CCFL HOT	CCFL high voltage

Note (1) Floating of any control signal is not allowed.

5.4 BLOCK DIAGRAM OF INTERFACE

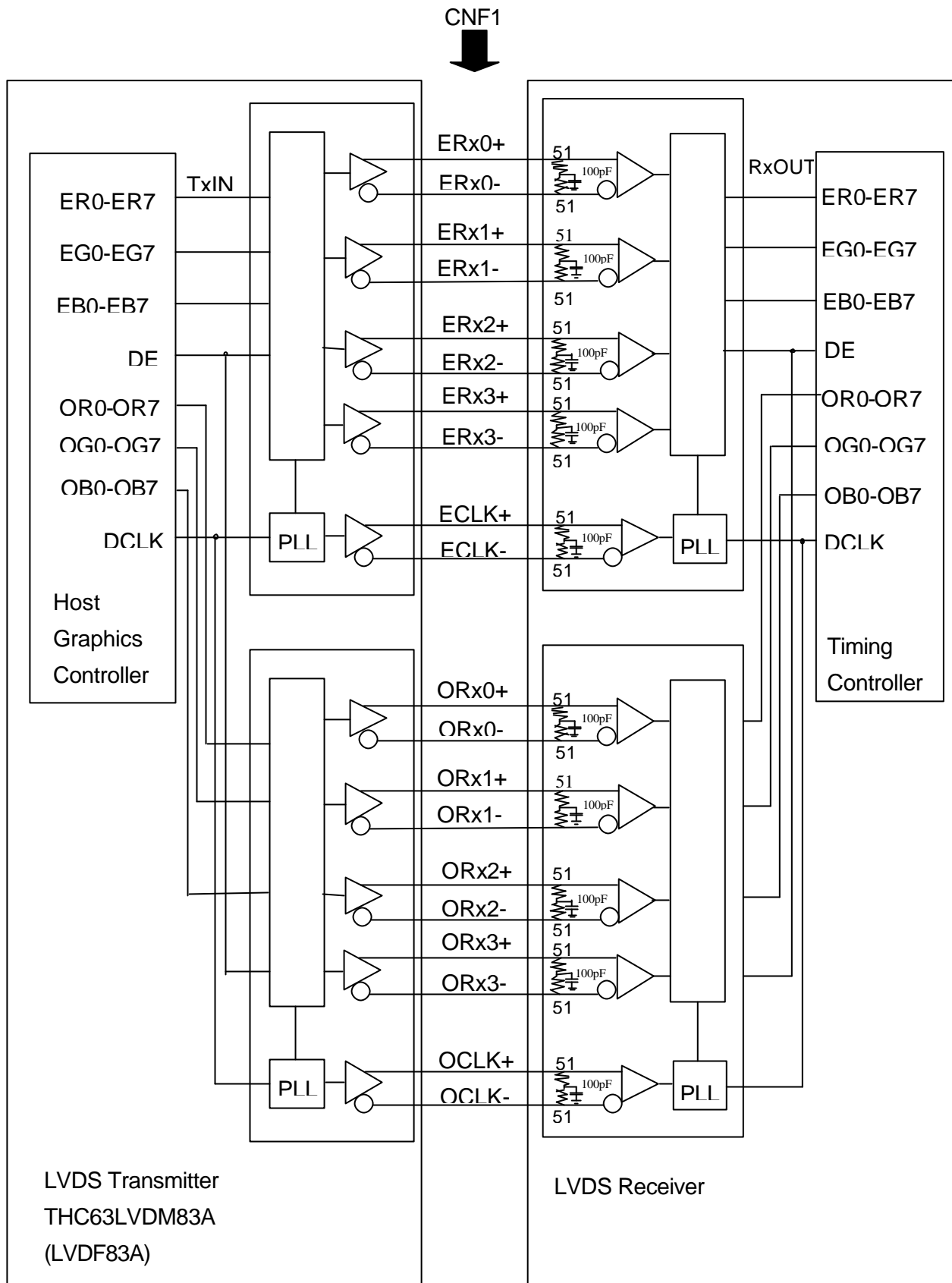

ER0~ER7 : Even pixel R data
EG0~EG7 : Even pixel G data
EB0~EB7 : Even pixel B data
OR0~OR7 : Odd pixel R data
OG0~OG7 : Odd pixel G data
OB0~OB7 : Odd pixel B data
DE : Data enable signal
DCLK : Data clock signal

- Notes: (1) The system must have the transmitter to drive the module.
- (2) LVDS cable impedance shall be 50 ohms per signal line or about 100 ohms per twist-pair line when it is used differentially.
- (3) Two pixel data send into the module for every clock cycle. The first pixel of the frame is even pixel and the second pixel is odd pixel.

5.5 LVDS INTERFACE

	SIGNAL	TRANSMITTER THC63LVDM83A		INTERFACE CONNECTOR		RECEIVER THC63LVDF84A		TFT CONTROL INPUT
		PIN	INPUT	Host	TFT-LCD	PIN	OUTPUT	
24bit	R0	51	TxIN0	TA OUT0+	Rx 0+	27	Rx OUT0	R0
	R1	52	TxIN1			29	Rx OUT1	R1
	R2	54	TxIN2			30	Rx OUT2	R2
	R3	55	TxIN3			32	Rx OUT3	R3
	R4	56	TxIN4	TA OUT0-	Rx 0-	33	Rx OUT4	R4
	R5	3	TxIN6			35	Rx OUT6	R5
	G0	4	TxIN7			37	Rx OUT7	G0
	G1	6	TxIN8	TA OUT1+	Rx 1+	38	Rx OUT8	G1
	G2	7	TxIN9			39	Rx OUT9	G2
	G3	11	TxIN12			43	Rx OUT12	G3
	G4	12	TxIN13	TA OUT1-	Rx 1-	45	Rx OUT13	G4
	G5	14	TxIN14			46	Rx OUT14	G5
	B0	15	TxIN15			47	Rx OUT15	B0
	B1	19	TxIN18	TA OUT2+	Rx 2+	51	Rx OUT18	B1
	B2	20	TxIN19			53	Rx OUT19	B2
	B3	22	TxIN20			54	Rx OUT20	B3
	B4	23	TxIN21	TA OUT2-	Rx 2-	55	Rx OUT21	B4
	B5	24	TxIN22			1	Rx OUT22	B5
	DE	30	TxIN26			6	Rx OUT26	DE
	R6	50	TxIN27	TA OUT3+	Rx 3+	7	Rx OUT27	R6
	R7	2	TxIN5			34	Rx OUT5	R7
	G6	8	TxIN10			41	Rx OUT10	G6
	G7	10	TxIN11	TA OUT3-	Rx 3-	42	Rx OUT11	G7
	B6	16	TxIN16			49	Rx OUT16	B6
	B7	18	TxIN17			50	Rx OUT17	B7
RSVD 1	25	TxIN23	TA OUT3-	Rx 3-	2	Rx OUT23	Not connect	
RSVD 2	27	TxIN24			3	Rx OUT24	Not connect	
RSVD 3	28	TxIN25			5	Rx OUT25	Not connect	
	DCLK	31	TxCLK IN	TxCLK OUT+ TxCLK OUT-	RxCLK IN+ RxCLK IN-	26	RxCLK OUT	DCLK

R0~R7: Pixel R Data (7; MSB, 0; LSB)

G0~G7: Pixel G Data (7; MSB, 0; LSB)

B0~B7: Pixel B Data (7; MSB, 0; LSB)

DE : Data enable signal

DCLK : Data clock signal

Notes: (1) RSVD (reserved) pins on the transmitter shall be "H" or "L".

5.6 COLOR DATA INPUT ASSIGNMENT

The brightness of each primary color (red, green and blue) is based on the 8-bit gray scale data input for the color. The higher the binary input, the brighter the color. The table below provides the assignment of the color versus data input.

Color		Data Signal																							
		Red								Green								Blue							
		R7	R6	R5	R4	R3	R2	R1	R0	G7	G6	G5	G4	G3	G2	G1	G0	B7	B6	B5	B4	B3	B2	B1	B0
Basic Colors	Black	0	0	0	0	0	0	0	0	0	0	0	0	0	0	0	0	0	0	0	0	0	0	0	0
	Red	1	1	1	1	1	1	1	1	0	0	0	0	0	0	0	0	0	0	0	0	0	0	0	0
	Green	0	0	0	0	0	0	0	0	1	1	1	1	1	1	1	1	0	0	0	0	0	0	0	0
	Blue	0	0	0	0	0	0	0	0	0	0	0	0	0	0	0	0	1	1	1	1	1	1	1	1
	Cyan	0	0	0	0	0	0	0	0	1	1	1	1	1	1	1	1	1	1	1	1	1	1	1	1
	Magenta	1	1	1	1	1	1	1	1	0	0	0	0	0	0	0	0	0	1	1	1	1	1	1	1
	Yellow	1	1	1	1	1	1	1	1	1	1	1	1	1	1	1	1	0	0	0	0	0	0	0	0
	White	1	1	1	1	1	1	1	1	1	1	1	1	1	1	1	1	1	1	1	1	1	1	1	1
Gray Scale Of Red	Red (0) / Dark	0	0	0	0	0	0	0	0	0	0	0	0	0	0	0	0	0	0	0	0	0	0	0	
	Red (1)	0	0	0	0	0	0	0	1	0	0	0	0	0	0	0	0	0	0	0	0	0	0	0	
	Red (2)	0	0	0	0	0	0	1	0	0	0	0	0	0	0	0	0	0	0	0	0	0	0	0	
	:	:	:	:	:	:	:	:	:	:	:	:	:	:	:	:	:	:	:	:	:	:	:	:	
	:	:	:	:	:	:	:	:	:	:	:	:	:	:	:	:	:	:	:	:	:	:	:	:	
	Red (253)	1	1	1	1	1	1	0	1	0	0	0	0	0	0	0	0	0	0	0	0	0	0	0	
	Red (254)	1	1	1	1	1	1	1	0	0	0	0	0	0	0	0	0	0	0	0	0	0	0	0	
	Red (255)	1	1	1	1	1	1	1	1	0	0	0	0	0	0	0	0	0	0	0	0	0	0	0	
Gray Scale Of Green	Green (0) / Dark	0	0	0	0	0	0	0	0	0	0	0	0	0	0	0	0	0	0	0	0	0	0	0	
	Green (1)	0	0	0	0	0	0	0	0	0	0	0	0	0	0	0	1	0	0	0	0	0	0	0	
	Green (2)	0	0	0	0	0	0	0	0	0	0	0	0	0	0	1	0	0	0	0	0	0	0	0	
	:	:	:	:	:	:	:	:	:	:	:	:	:	:	:	:	:	:	:	:	:	:	:	:	
	:	:	:	:	:	:	:	:	:	:	:	:	:	:	:	:	:	:	:	:	:	:	:	:	
	Green (253)	0	0	0	0	0	0	0	0	1	1	1	1	1	1	0	1	0	0	0	0	0	0	0	
	Green (254)	0	0	0	0	0	0	0	0	1	1	1	1	1	1	1	0	0	0	0	0	0	0	0	
	Green (255)	0	0	0	0	0	0	0	0	1	1	1	1	1	1	1	1	0	0	0	0	0	0	0	
Gray Scale Of Blue	Blue (0) / Dark	0	0	0	0	0	0	0	0	0	0	0	0	0	0	0	0	0	0	0	0	0	0	0	
	Blue (1)	0	0	0	0	0	0	0	0	0	0	0	0	0	0	0	0	0	0	0	0	0	0	1	
	Blue (2)	0	0	0	0	0	0	0	0	0	0	0	0	0	0	0	0	0	0	0	0	0	0	1	
	:	:	:	:	:	:	:	:	:	:	:	:	:	:	:	:	:	:	:	:	:	:	:	:	
	:	:	:	:	:	:	:	:	:	:	:	:	:	:	:	:	:	:	:	:	:	:	:	:	
	Blue (253)	0	0	0	0	0	0	0	0	0	0	0	0	0	0	0	0	1	1	1	1	1	1	0	
	Blue (254)	0	0	0	0	0	0	0	0	0	0	0	0	0	0	0	0	1	1	1	1	1	1	0	
	Blue (255)	0	0	0	0	0	0	0	0	0	0	0	0	0	0	0	0	1	1	1	1	1	1	1	

Note: (1) 0: Low Level Voltage, 1: High Level Voltage

6. INTERFACE TIMING

6.1 INPUT SIGNAL TIMING SPECIFICATIONS

The input signal timing specifications are shown as the following table and timing diagram.

Signal	Item	Symbol	Min.	Typ.	Max.	Unit	Note
LVDS Receiver Clock	Frequency	1/Tc	60	74	80	MHZ	
	Input cycle to cycle jitter	Trcl	-	-	200	ps	-
LVDS Receiver Data	Setup Time	Tlvsu	600	-	-	ps	
	Hold Time	Tlvhd	600	-	-	ps	
Vertical Active Display Term	Frame Rate	Fr5	47	50	53	Hz	(2)
		Fr6	57	60	63	Hz	(3)
	Total	Tv	1115	1125	1135	Th	Tv=Tvd+Tvb
	Display	Tvd	1080	1080	1080	Th	-
Horizontal Active Display Term	Blank	Tvb	35	45	55	Th	-
	Total	Th	2100	2200	2300	Tc	Th=Thd+Thb
	Display	Thd	1920	1920	1920	Tc	-
Horizontal Active Display Term	Blank	Thb	180	280	380	Tc	-

Note: (1) Since this module is operated in DE only mode, Hsync and Vsync input signals should be set to low logic level. Otherwise, this module would operate abnormally.

(2) ODSEL = H. Please refer to 5.1 for detail information.

(3) ODSEL = L. Please refer to 5.1 for detail information.

INPUT SIGNAL TIMING DIAGRAM

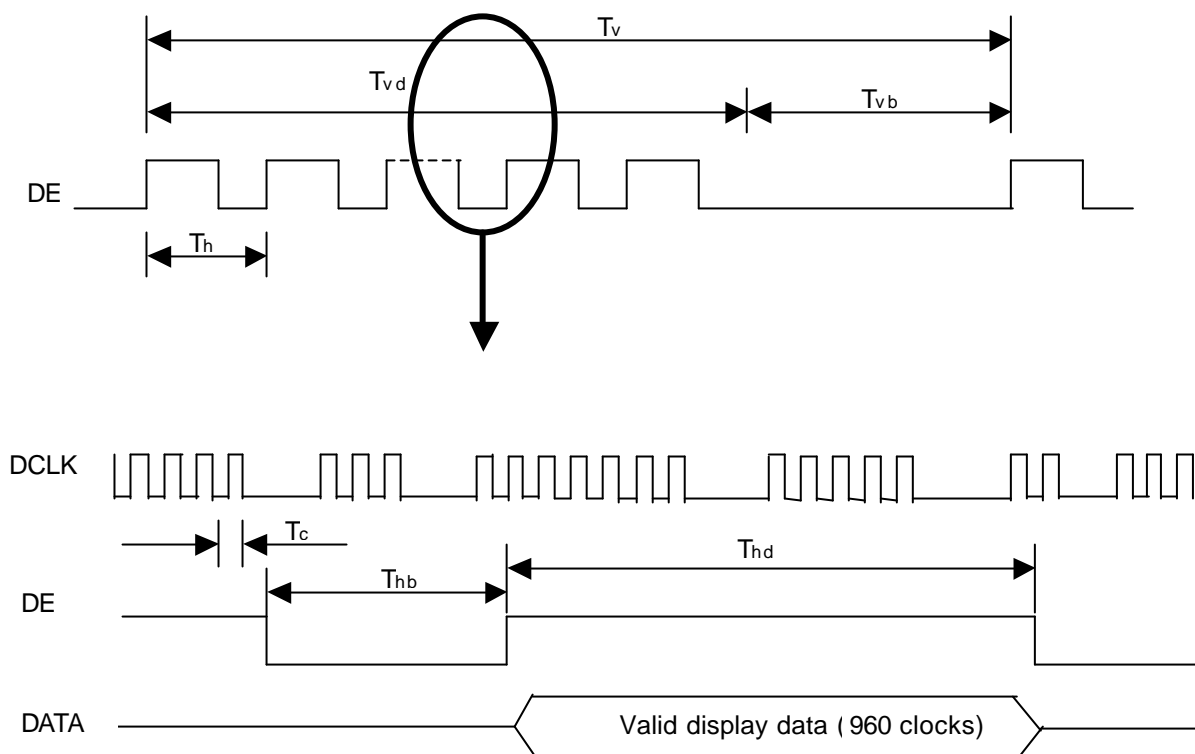

LVDS INPUT INTERFACE TIMING DIAGRAM

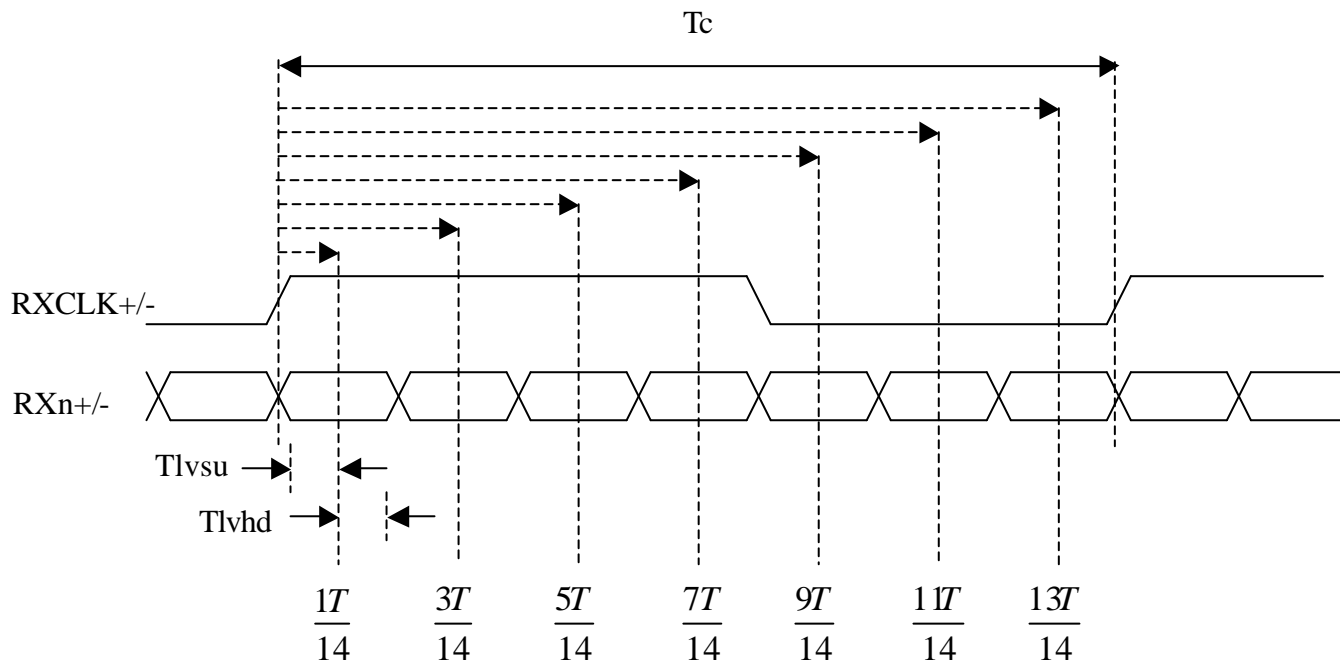

6.2 POWER ON/OFF SEQUENCE

To prevent a latch-up or DC operation of LCD module, the power on/off sequence should follow the diagram below.

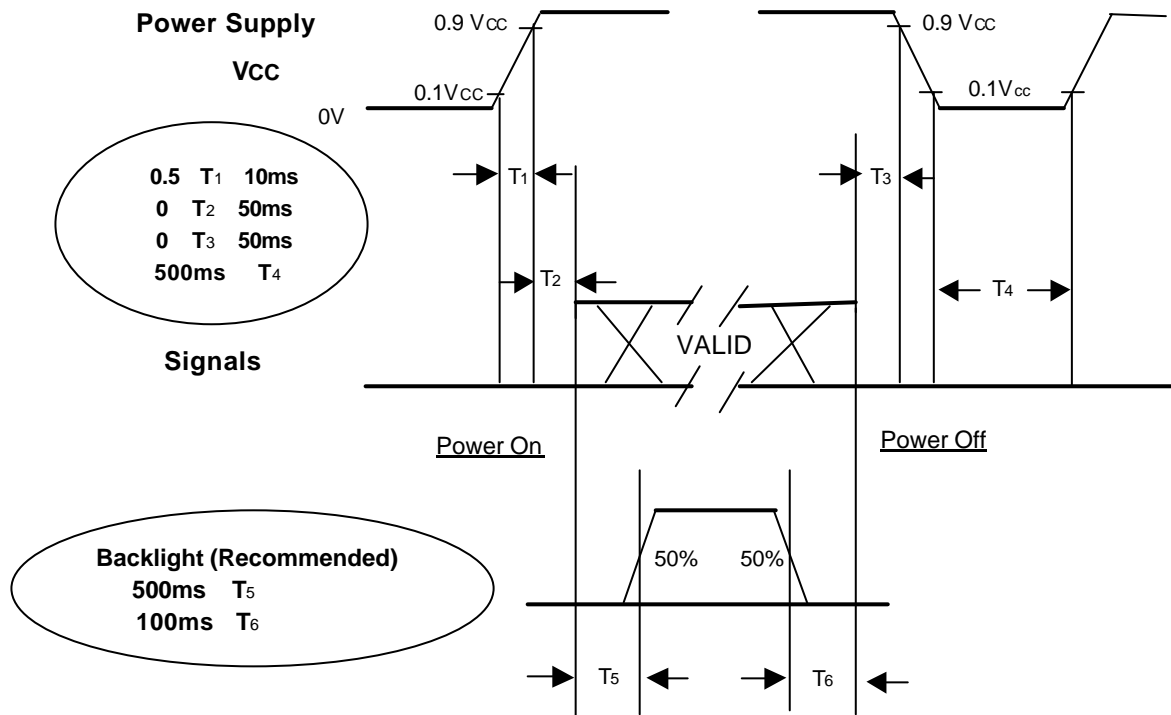

Power ON/OFF Sequence

- Note :
- (1) The supply voltage of the external system for the module input should follow the definition of V_{CC}.
 - (2) Apply the lamp voltage within the LCD operation range. When the backlight turns on before the LCD operation or the LCD turns off before the backlight turns off, the display may momentarily become abnormal screen.
 - (3) In case of V_{CC} is in off level, please keep the level of input signals on the low or high impedance.
 - (4) T₄ should be measured after the module has been fully discharged between power off and on period.
 - (5) Interface signal shall not be kept at high impedance when the power is on.

7. OPTICAL CHARACTERISTICS

7.1 TEST CONDITIONS

Item	Symbol	Value	Unit
Ambient Temperature	T _a	25±2	°C
Ambient Humidity	H _a	50±10	%RH
Supply Voltage	V _{CC}	12/18	V
Input Signal	According to typical value in "3. ELECTRICAL CHARACTERISTICS"		
Lamp Current	I _L	5.2±0.5	mA
Oscillating Frequency (Inverter)	F _L	50±3	KHz
Frame Rate	F _r	60	Hz

7.2 OPTICAL SPECIFICATIONS

The relative measurement methods of optical characteristics are shown in 7.2. The following items should be measured under the test conditions described in 7.1 and stable environment shown in Note (6).

Item		Symbol	Condition	Min.	Typ.	Max.	Unit	Note	
Contrast Ratio		CR	$\theta_x=0^\circ, \theta_y=0^\circ$ Viewing Normal Angle	900	1200	-	-	Note (2)	
Response Time		Gray to Gray average		-	6.5	12	ms	Note (3)	
Center Luminance of White		L _C		400	500	-	cd/m ²	Note (4)	
Average Luminance of White		L _{AVE}		350	450	-	cd/m ²	Note (4)	
White Variation		δW		-	-	1.3	-	Note (7)	
Cross Talk		CT		-	-	4.0	%	Note (5)	
Color Chromaticity	Red	R _x		Viewing Normal Angle	Typ. -0.03	0.651	Typ. +0.03	-	Note (6)
		R _y				0.331			
	Green	G _x				0.274			
		G _y				0.595			
	Blue	B _x	0.142						
		B _y	0.067						
	White	W _x	0.285						
		W _y	0.293						
Viewing Angle	Horizontal	θ_{x+}	CR≥20	80	88	-	Deg.	Note (1)	
		θ_{x-}			88				
	Vertical	θ_{y+}			88				
		θ_{y-}			88				

Note (1) Definition of Viewing Angle (θ_x , θ_y):

Viewing angles are measured by Eldim EZ-Contrast 160R

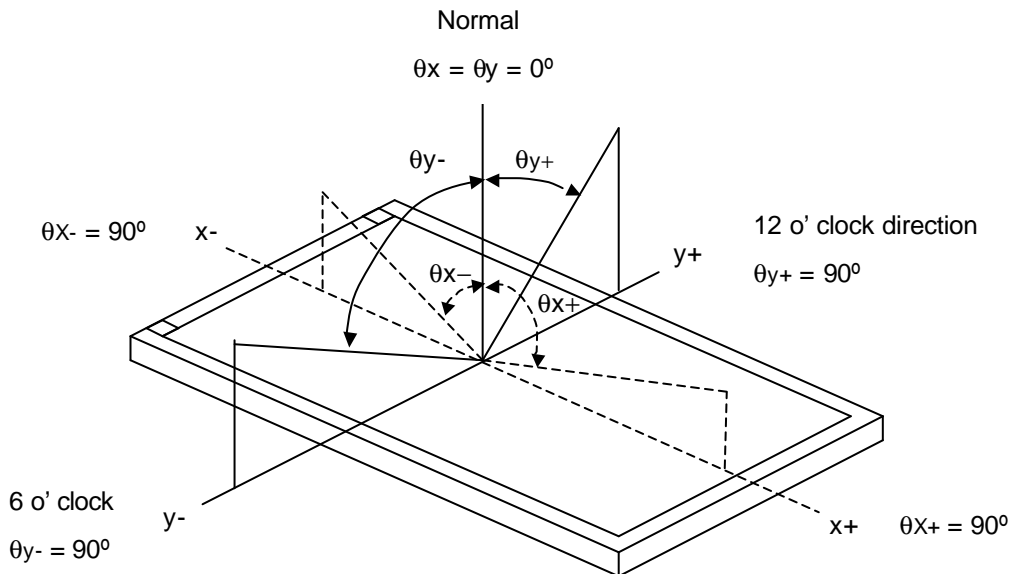

Note (2) Definition of Contrast Ratio (CR):

The contrast ratio can be calculated by the following expression.

$$\text{Contrast Ratio (CR)} = L_{255} / L_0$$

L255: Luminance of gray level 255

L 0: Luminance of gray level 0

CR = CR (X), where CR (X) is corresponding to the Contrast Ratio of the point X at the figure in Note (7).

Note (3) Definition of Gray to Gray Switching Time:

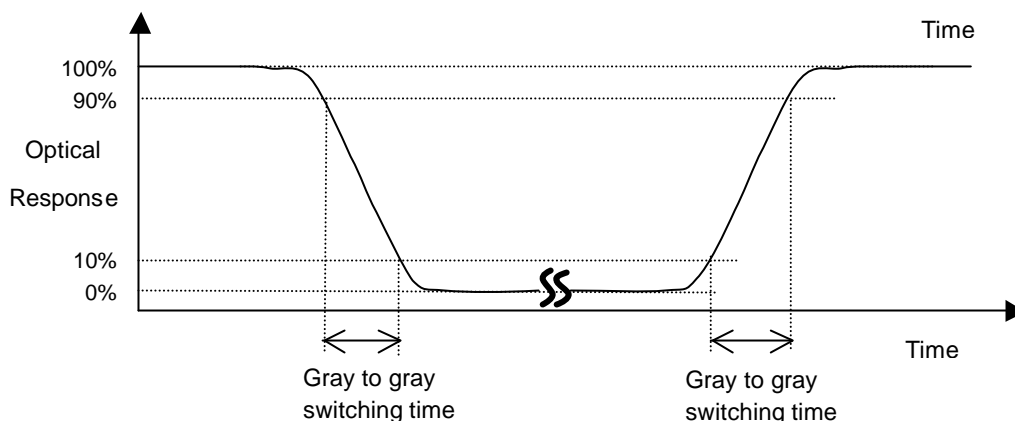

The driving signal means the signal of gray level 0, 63, 127, 191, 255.

Gray to gray average time means the average switching time of gray level 0, 63, 127, 191, 255 to each other.

Note (4) Definition of Luminance of White (L_C , L_{AVE}):

Measure the luminance of gray level 255 at center point and 5 points

$$L_C = L(5)$$

$$L_{AVE} = [L(1) + L(2) + L(3) + L(4) + L(5)] / 5,$$

where $L(x)$ is corresponding to the luminance of the point X at the figure in Note (7).

Note (5) Definition of Cross Talk (CT):

$$CT = |Y_B - Y_A| / Y_A \times 100 (\%)$$

Where:

Y_A = Luminance of measured location without gray level 0 pattern (cd/m^2)

Y_B = Luminance of measured location with gray level 0 pattern (cd/m^2)

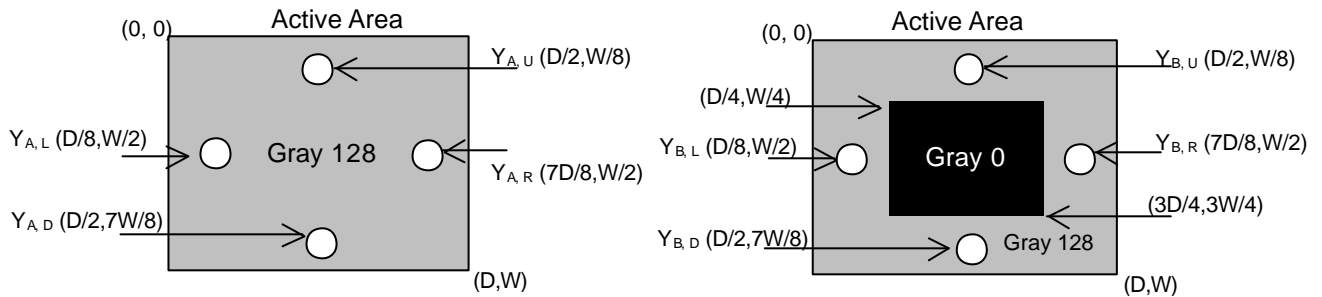

Note (6) Measurement Setup:

The LCD module should be stabilized at given temperature for 1 hour to avoid abrupt temperature change during measuring. In order to stabilize the luminance, the measurement should be executed after lighting backlight for 1 hour in a windless room.

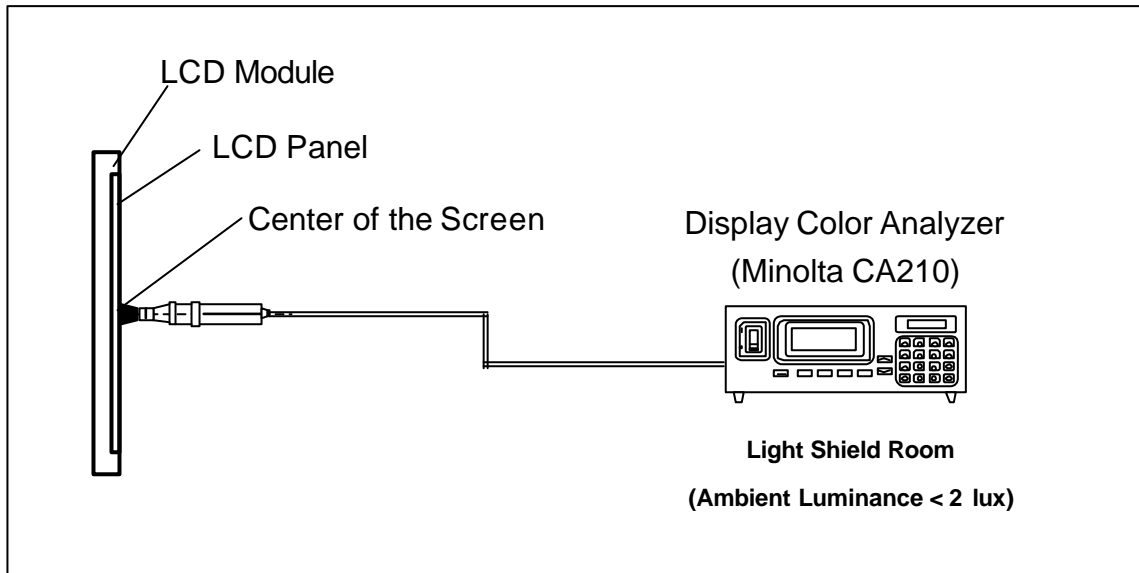

Note (7) Definition of White Variation (δW):

Measure the luminance of gray level 255 at 5 points

$$\delta W = \text{Maximum} [L (1), L (2), L (3), L (4), L (5)] / \text{Minimum} [L (1), L (2), L (3), L (4), L (5)]$$

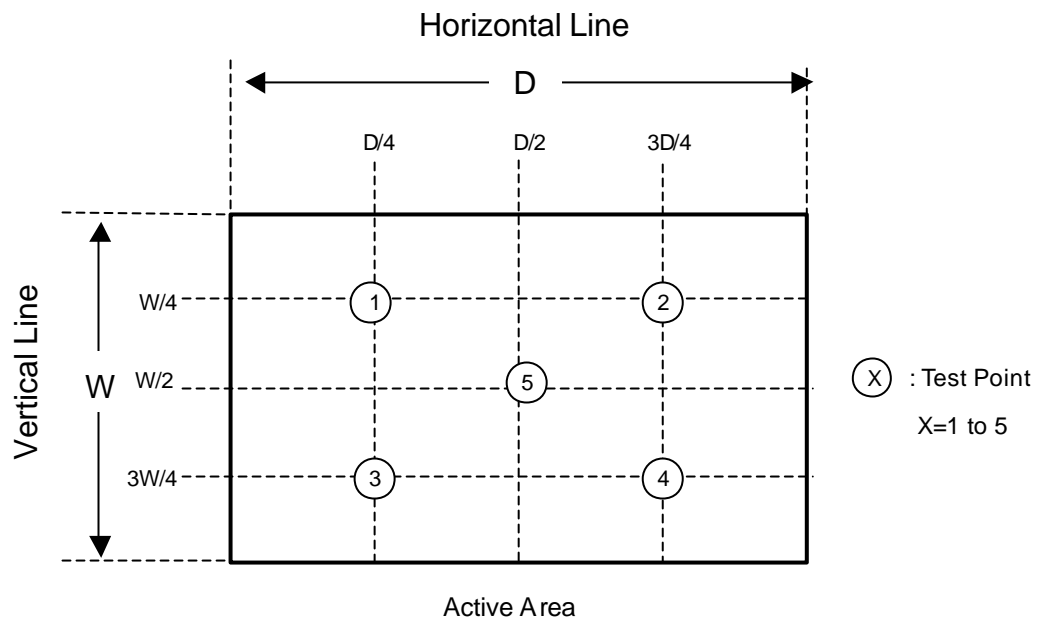

8. DEFINITION OF LABELS

8.1 CMO MODULE LABEL

The barcode nameplate is pasted on each module as illustration, and its definitions are as following explanation.

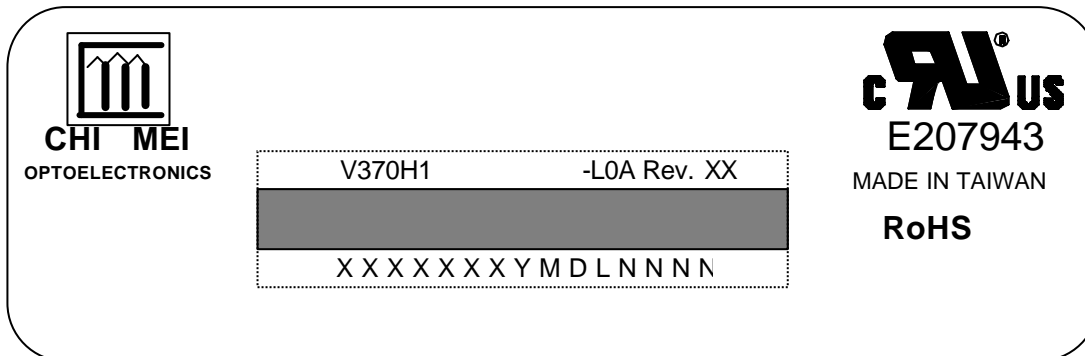

- (a) Model Name: V370H1-L0A
- (b) Revision: Rev. XX, for example: A0, A1... B1, B2... or C1, C2... etc.
- (c) Serial ID: X X X X X X Y M D L N N N N

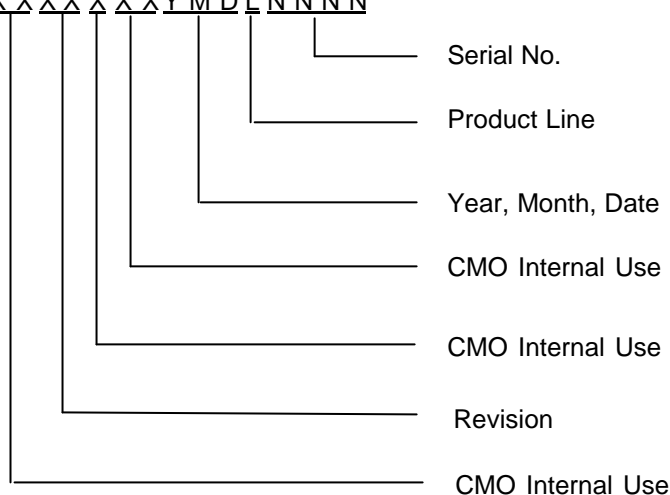

Serial ID includes the information as below:

- (a) Manufactured Date: Year: 0~9, for 2000~2009
Month: 1~9, A~C, for Jan. ~ Dec.
Day: 1~9, A~Y, for 1st to 31st, exclude I ,O, and U.
- (b) Revision Code: Cover all the change
- (c) Serial No.: Manufacturing sequence of product
- (d) Product Line: 1 -> Line1, 2 -> Line 2, ...etc.

9. PACKAGING

9.1 PACKING SPECIFICATIONS

- (1) 3 LCD TV modules / 1 Box
- (2) Box dimensions : 1048(L) X 345 (W) X 676 (H)
- (3) Weight : approximately 33Kg (3 modules per box)

9.2 PACKING METHOD

Figures 9-1 and 9-2 are the packing method

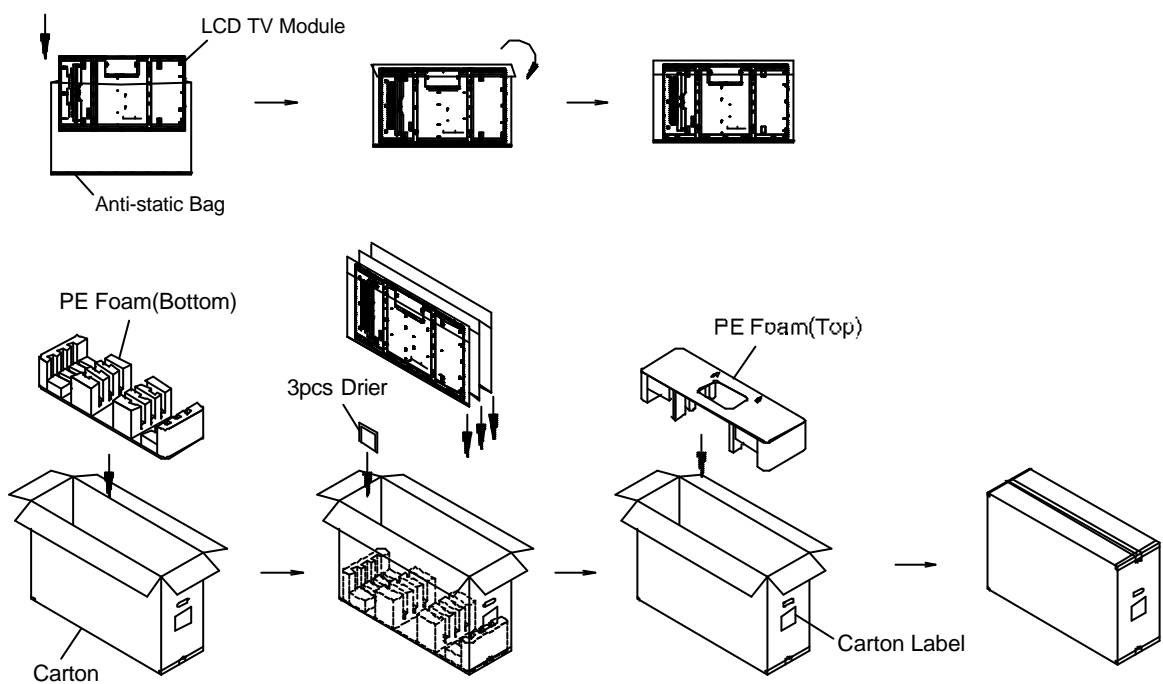

Figure.9-1 packing method

Corner Protector:L1350*50mm*50mm
L1000*50mm*50mm
Pallet:L1100*W1100*H140mm
Corrugated Fiberboard:L1100*W1100mm
Pallet Stack:L1100*W1100*H1500mm
Gross:218kg

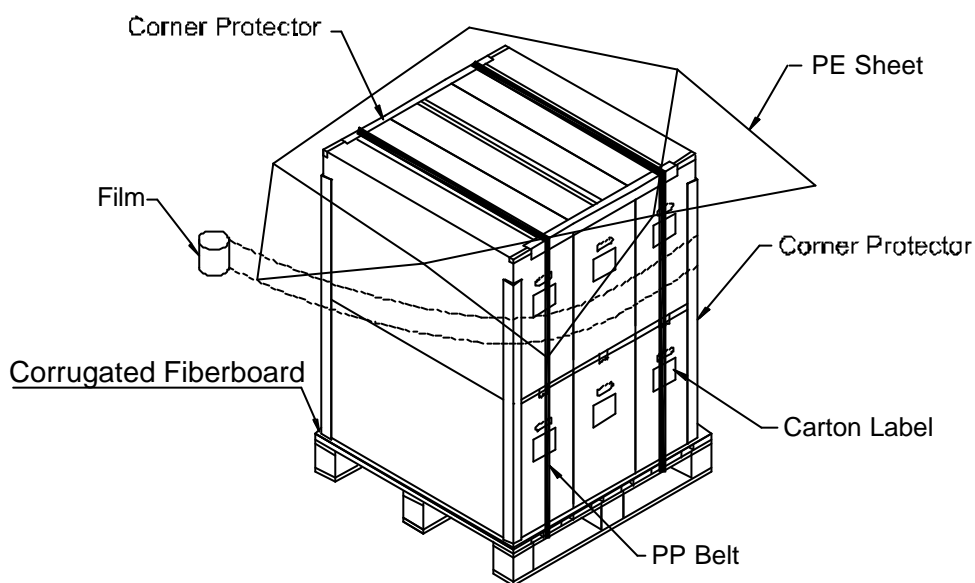

Figure. 9-2 Packing method

10. PRECAUTIONS

10.1 ASSEMBLY AND HANDLING PRECAUTIONS

- (1) Do not apply rough force such as bending or twisting to the module during assembly.
- (2) It is recommended to assemble or to install a module into the user's system in clean working areas. The dust and oil may cause electrical short or worsen the polarizer.
- (3) Do not apply pressure or impulse to the module to prevent the damage of LCD panel and Backlight.
- (4) Always follow the correct power-on sequence when the LCD module is turned on. This can prevent the damage and latch-up of the CMOS LSI chips.
- (5) Do not plug in or pull out the I/F connector while the module is in operation.
- (6) Do not disassemble the module.
- (7) Use a soft dry cloth without chemicals for cleaning, because the surface of polarizer is very soft and easily scratched.
- (8) Moisture can easily penetrate into LCD module and may cause the damage during operation.
- (9) High temperature or humidity may deteriorate the performance of LCD module. Please store LCD modules in the specified storage conditions.
- (10) When ambient temperature is lower than 10°C, the display quality might be reduced. For example, the response time will become slow, and the starting voltage of CCFL will be higher than that of room temperature.

10.2 SAFETY PRECAUTIONS

- (1) The startup voltage of a Backlight is approximately 1000 Volts. It may cause an electrical shock while assembling with the inverter. Do not disassemble the module or insert anything into the Backlight unit.
- (2) If the liquid crystal material leaks from the panel, it should be kept away from the eyes or mouth. In case of contact with hands, skin or clothes, it has to be washed away thoroughly with soap.
- (3) After the module's end of life, it is not harmful in case of normal operation and storage.

