

Product Specification

SPECIFICATION FOR APPROVAL

- () Preliminary Specification
- () Final Specification

Title	6.4" VGA TFT LCD
-------	------------------

BUYER	
MODEL	

SUPPLIER	LG.Philips LCD CO., Ltd.
*MODEL	LB064V02
SUFFIX	B1

*When you obtain standard approval, please use the above model name without suffix

SIGNATURE	DATE
_____/_____ /	_____
_____/_____ /	_____
_____/_____ /	_____

APPROVED BY	DATE
C. S. Kyoung G.Manager _____ /	_____
REVIEWED BY	
H.J. Kim Manager _____ /	_____
PREPARED BY	
Y. I. Bang Research Engineer _____ /	_____
J. H. Kim Assistant Research Engineer _____ /	_____

Please return 1 copy for your confirmation with your signature and comments.

**Product Engineering Dept.
LG. Philips LCD Co., Ltd**

Product Specification

NO.	ITEM	Page
-	COVER	1
-	CONTENTS	2
-	RECORD OF REVISIONS	3
1	GENERAL DESCRIPTION	4
2	ABSOLUTE MAXIMUM RATINGS	5
3	ELECTRICAL SPECIFICATIONS	6
3-1	ELECTRICAL CHARACTREISTICS	6
3-2	INTERFACE CONNECTIONS	8
3-3	SIGNAL TIMING SPECIFICATIONS	9
3-4	SIGNAL TIMING WAVEFORMS	10
3-5	COLOR INPUT DATA REFERNECE	11
3-6	POWER SEQUENCE	12
4	OPTICAL SPECIFICATIONS	13
5	MECHANICAL CHARACTERISTICS	17
6	TOUCH PANEL CHARACTERISTICS	21
7	RELIABILITY	24
8	INTERNATIONAL STANDARDS	25
8-1	SAFETY	25
8-2	EMC	25
9	PACKING	26
9-1	DESIGNATION OF LOT MARK	26
9-2	PAKING FORM	26
10	PRECAUTIONS	27
11	IIS(Incoming Inspection Standard)	29

Product Specification

RECORDS OF REVISIONS

Revision No	Revision No	Page	DESCRIPTION
0.0	DEC 31,2002	-	First Draft
0.1	JAN 27,2003	6	Modified a electrical characteristics - P_C , V_{BL} , V_s , f_{BL} , T_s , P_{BL} , Lamp Life time
		18~20	Modified a mechanical draw by Buyer request
0.2	MAR. 18, 2003	4	Modified a general features - measuring point of luminance - power consumption
		6	Modified a electrical characteristics - lamp life time
		9	Modified CN3 draw
		19	Modified Mechanical Characteristic Rear View
		27	Modified 10-1 (9) Cleaning materials

Product Specification

1. General Description

The LB064V02-B1 is a Color Active Matrix Liquid Crystal Display with an integral Cold Cathode Fluorescent Lamp(CCFL) backlight system. The matrix employs a-Si Thin Film Transistor as the active element. It is a transmissive type display operating in the normally white mode. This TFT-LCD has 6.4 inches diagonally measured active display area with VGA resolution(480 vertical by 640 horizontal pixel array) Each pixel is divided into Red, Green and Blue sub-pixels or dots which are arranged in vertical stripes. Gray scale or the brightness of the sub-pixel color is determined with a 6-bit gray scale signal for each dot, thus, presenting a palette of more than 262,144 colors. The LB064V02-B1 has been designed to apply the interface method that enables low power consumption, weight and thickness are critical factors and graphic display are important. In combination with the vertical arrangement of the sub-pixels, the LB064V02-B1 characteristics provide an excellent flat display for office automation products such as portable Computer.

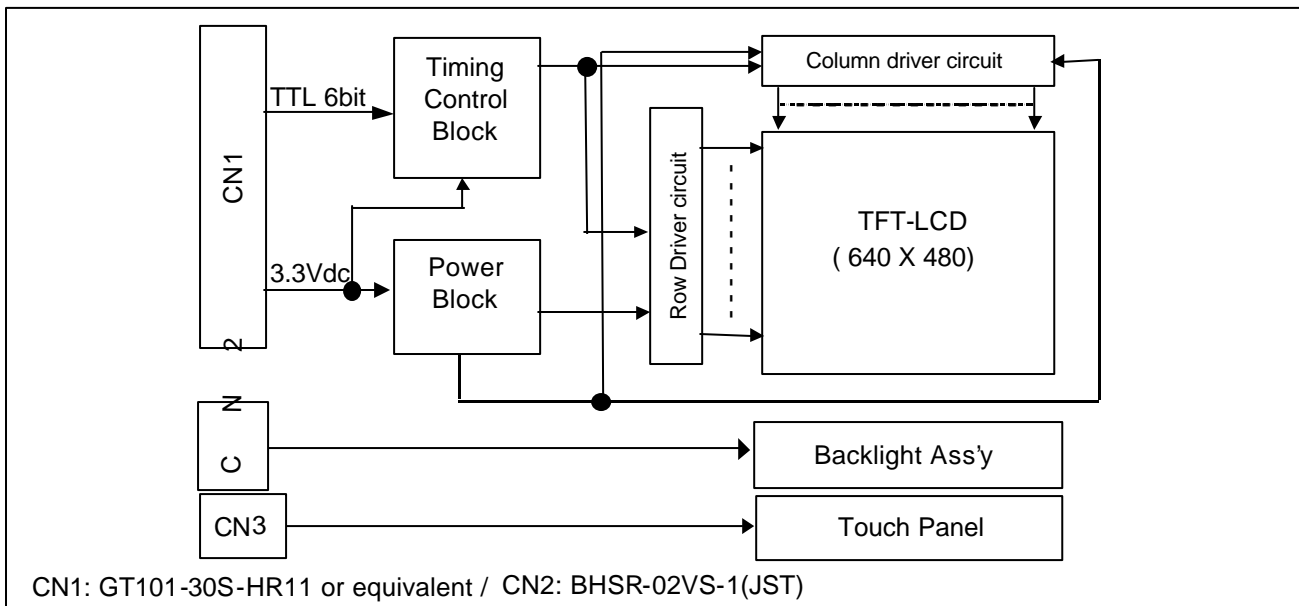

General Features

Active screen size	6.4 inches (163.2mm) diagonal
Outline Dimension	145.5(H) x 111.5(V) x 6.7(D) mm(Typ.)
Pixel Pitch	0.204 mm x 0.204mm
Pixel format	640 horiz. By 480 vert. Pixels RGB stripes arrangement
Color depth	6-bit, 262,144 colors
Luminance, white	200 cd/m ² (Typ. 1point)
Power Consumption	2.310 Watt (Typ.)
Weight	175g(Typ.)
Display operating mode	Transmissive mode, Normally white
Surface treatments	Anti-glare & Hard coating(3H)

Product Specification

2. Absolute Maximum Ratings

The following are maximum values which, if exceeded, may cause faulty operation or damage to the unit.

Table 1. ABSOLUTE MAXIMUM RATINGS TBD

Parameter	symbol	Values		Units	Notes
		Min.	Max.		
Power Input Voltage	V_{CC}	-0.3	4.0	Vdc	At $25 \pm 5^{\circ}\text{C}$
Operating Temperature	T_{OP}	0	50	$^{\circ}\text{C}$	1
Storage Temperature	T_{ST}	-20	60	$^{\circ}\text{C}$	1
Operating Ambient Humidity	H_{OP}	10	90	%RH	1
Storage Humidity	H_{ST}	10	90	%RH	1

Note : 1. Temperature and relative humidity range are shown in the figure below.
 Wet bulb temperature should be 39 °C Max, and no condensation of water.

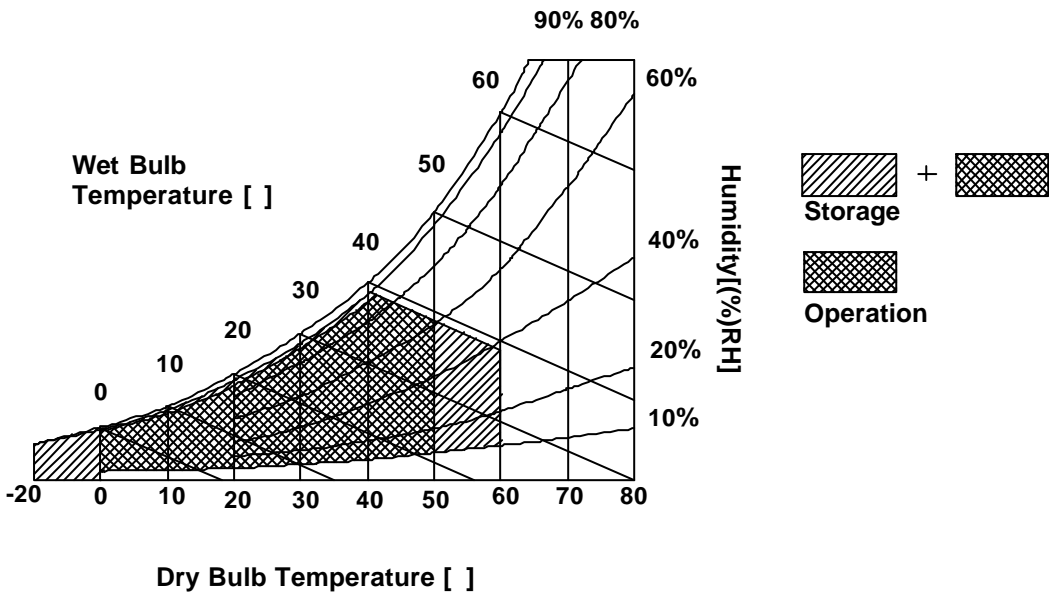

Product Specification

3. Electrical Specifications

3-1. Electrical Characteristics

The LB064V02-B1 requires two power inputs. One is employed to power the LCD electronics and to drive the TFT array and liquid crystal. The second input which powers the CCFL, is typically generated by an inverter. The inverter is an external unit to the LCD.

Table 2. ELECTRICAL CHARACTERISTICS

TBD

Parameter	Symbol	Values			Units	Notes
		Min.	Typ.	Max.		
MODULE :						
Power Supply Input Voltage	V_{CC}	3.0	3.3	3.6	Vdc	
Power Supply Input Current	I_{CC}	136	160	184	mA	1
Power Consumption	P_C	-	0.530	0.636	Watts	1
LAMP :						
Operating Voltage	V_{BL}	325	355	380	V_{RMS}	2
Operating Current	I_{BL}	2.0	5.0	7.0	mA	3
Established Starting Voltage	V_S					4
at 25 °C		-	-	1000	V_{RMS}	
at 0 °C		-	-	1200	V_{RMS}	
Operating Frequency	f_{BL}	40	60	80	kHz	5
Discharge Stabilization Time	T_s			1	Minutes	6
Power Consumption	P_{BL}	-	1.78	2.28	Watts	7
Life Time		20,000	-	-	Hrs	8
TOUCH PANEL						
Operating Voltage		-	5	-	Vdc	9

Note : **The design of the inverter must have specification for the lamp in LCD Assembly.**

The performance of the Lamp in LCM, for example life time or brightness, is extremely influenced by the characteristics of the DC-AC inverter. So all the parameters of an inverter should be carefully designed so as not to produce too much leakage current from high-voltage output of the inverter.

When you design or order the inverter, please make sure unwanted lighting caused by the mismatch of the lamp and the inverter(no lighting, flicker, etc) never occurs. When you confirm it, the LCD Assembly should be operated in the same condition as installed in you instrument.

1. The specified current and power consumption are under the $V_{CC}=3.3V$, $25^{\circ}C$, $f_v=60Hz$ condition whereas mosaic pattern is displayed and f_v is the frame frequency.
2. The variance of the voltage is $\pm 10\%$.
3. Do not attach a conducting tape to lamp connecting wire.

If the lamp wire attach to a conducting tape, TFT-LCD Module has a low luminance and the inverter has abnormal action. Because leakage current is occurred between lamp wire and conducting tape.

4. The voltage above V_S should be applied to the lamps for more than 1 second for start-up.

Otherwise, the lamps may not be turned on. The used lamp current is the lamp typical current.

Product Specification

5. The output of the inverter must have symmetrical(negative and positive) voltage waveform and symmetrical current waveform.(Unsymmetrical ratio is less than 10%) Please do not use the inverter which has unsymmetrical voltage and unsymmetrical current and spike wave.
Lamp frequency may produce interface with horizontal synchronous frequency and as a result this may cause beat on the display. Therefore lamp frequency shall be as away possible from the horizontal synchronous frequency and from its harmonics in order to prevent interference.
6. Let's define the brightness of the lamp after being lighted for 5 minutes as 100%.
 T_s is the time required for the brightness of the center of the lamp to be not less than 95%.
7. The lamp power consumption shown above does not include loss of external inverter.
The used lamp current is the lamp typical current.
8. The life is determined as the time at which brightness of the lamp is 50% compared to that of initial value at **the typical lamp current** on condition of continuous operating at $25 \pm 2^\circ\text{C}$.
9. Optimum Touch Panel Operating voltage value :
 - The referred characteristics such as power consumption, max current are highly dependent on touch controller specification.
 - for reference only
 - 1) resistance : 300
 - 2) voltage : 5V
 - 3) max current : less than 16.7mA

Product Specification

3-2. Interface Connections

This LCD employs two interface connections, a 30 pin connector is used for the module electronics and the other connector is used for the integral backlight system.

The electronics interface connector is a model GT101-30S-HR11 manufactured by LG Cable.

The pin configuration for the connector is shown in the table below.

Table 3. MODULE CONNECTOR PIN CONFIGURATION

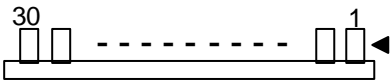
Pin	Symbol	Description	Notes
1	GND	Ground	1. Connector 1.1 LCD : GT101-30S-HR11 (LG Cable) 1.2 Mating : FI-X30M (JAE) or equivalent 2.3 Connector pin arrangement  <p>[LCD Module Rear View]</p>
2	VCC	Power (3.3V)	
3	VCC	Power (3.3V)	
4	GND	Ground	
5	DCLK	Data Input Clock	
6	DE	Data Enable Signal	
7	VSYNC	Vertical Sync Signal	
8	HSYNC	Horizontal Sync Signal	
9	GND	Ground	
10	R0	Red Data 0[LSB]	
11	R1	Red Data 1	
12	R2	Red Data 2	
13	R3	Red Data 3	
14	R4	Red Data 4	
15	R5	Red Data 5[MSB]	
16	GND	Ground	
17	G0	Green Data 0[LSB]	
18	G1	Green Data 1	
19	G2	Green Data 2	
20	G3	Green Data 3	
21	G4	Green Data 4	
22	G5	Green Data 5[MSB]	
23	GND	Ground	
24	B0	Blue Data 0[LSB]	
25	B1	Blue Data 1	
26	B2	Blue Data 2	
27	B3	Blue Data 3	
28	B4	Blue Data 4	
29	B5	Blue Data 5[MSB]	
30	GND	Ground	

The backlight interface connector is a model BHSR-02VS-1, manufactured by JST. The mating connector part number is SM02B-BHSS-1 by JST or equivalent.

The pin configuration for the connector is shown in the table below.

Table 4. BACKLIGHT CONNECTOR PIN CONFIGURATION

Pin	Symbol	Description	Notes
1	HV	Power supply for lamp(High voltage side)	1
2	LV	Power supply for lamp(Low voltage side)	1

Notes : 1. The high voltage side terminal is colored pink. The low voltage side terminal is white.

Product Specification

<DETAIL DESCRIPTION OF TAIL(CN3) FOR TOUCH SCREEN>

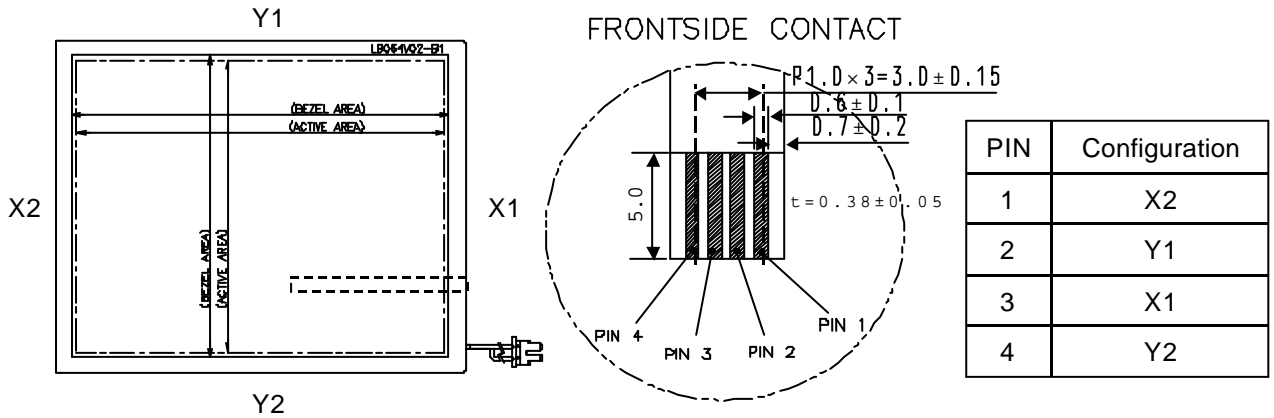

3-3. Signal Timing Specifications

This is the signal timing required at the input of the User connector. All of the interface signal timing should be satisfied with the following specifications for its proper operation.

ITEM		SYMBOL	MIN	TYP.	MAX.	UNIT	NOTES
Dclk	Period	t_{CLK}	35	39.7	46	ns	
	Frequency	fclk	22	25	28	MHz	
Hsync	Period	t_{HP}	696	800	880	t_{CLK}	
	Width	t_{WH}	24	96	144		
Vsync	Period	t_{VP}	486	525	-	t_{HP}	
	Frequency	f_V	55	60	65	Hz	
	Width	t_{VW}	2	2	-	t_{HP}	
DE (Data Enable)	Horizontal Valid	t_{HV}	640	640	640	t_{CLK}	
	Horizontal Back Porch	t_{HBP}	16	40	-		
	Horizontal Front Porch	t_{HFP}	16	24	-		
	Horizontal Blank	-	56	160	$t_{HP} - t_{HV}$		$t_{WH} + t_{HBP} + t_{HFP}$
	Vertical Valid	t_{VV}	480	480	480	t_{HP}	
	Vertical Back Porch	t_{VBP}	2	33	-		
	Vertical Front Porch	t_{VFP}	2	10	-		
	Vertical Blank	-	6	45	$t_{VP} - t_{VW}$		$t_{VW} + t_{VBP} + t_{VFP}$

1. Hsync Period and Hsync Width-Active should be even number times of t_{CLK} .
If the value is odd number times of t_{CLK} , display control signal can be asynchronous

Product Specification

3-4. Signal Timing Waveforms

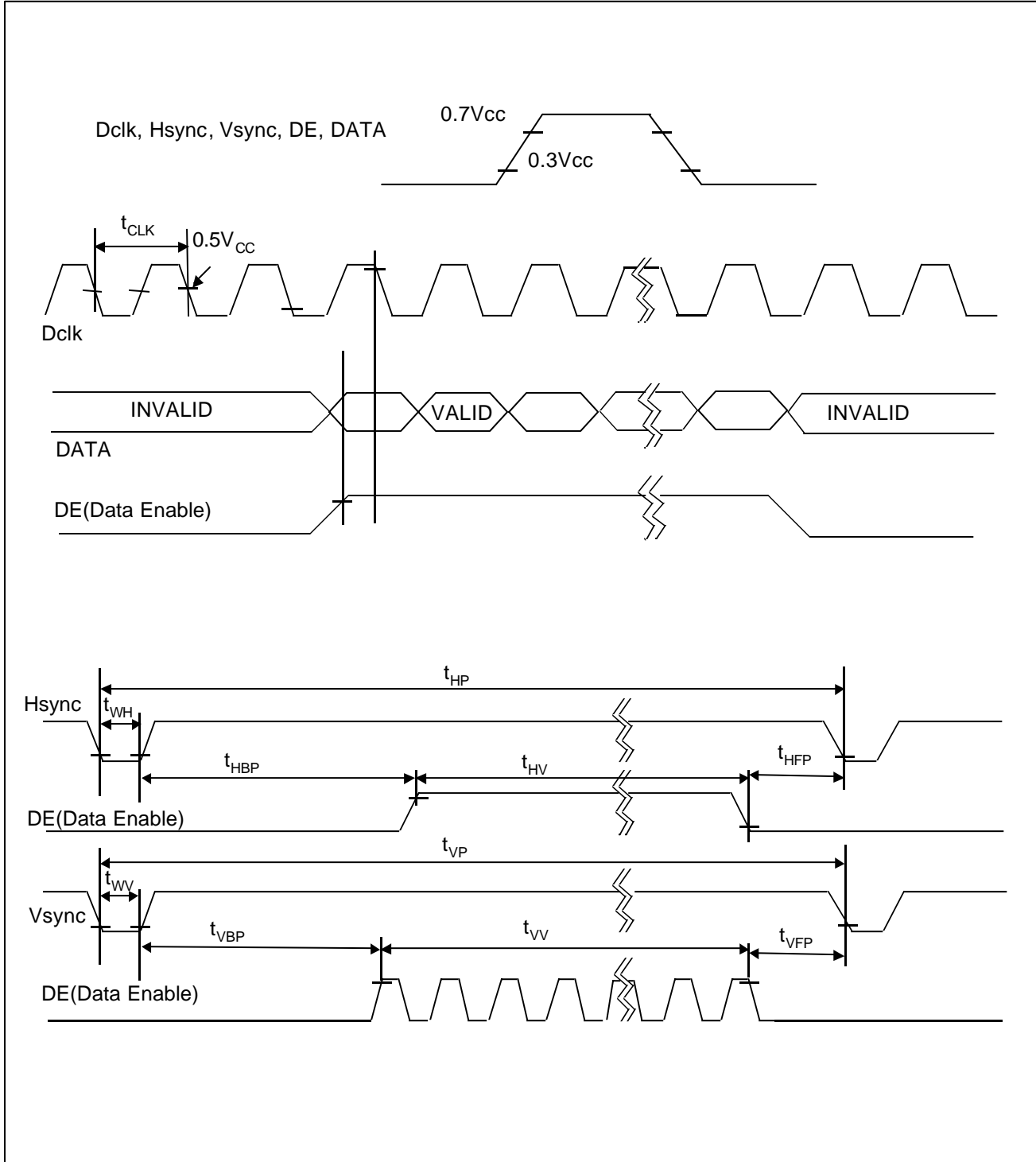

Product Specification

3-5. Color Input Data Reference

The brightness of each primary color(red,green and blue) is based on the 6-bit gray scale data input for the color ; the higher the binary input, the brighter the color. The table below provides a reference for color versus data input.

Table 7. COLOR DATA REFERENCE

Color		Input Color Data																	
		Red						Green						Blue					
		MSB		LSB				MSB		LSB				MSB		LSB			
	R5	R4	R3	R2	R1	R0	G5	G4	G3	G2	G1	G0	B5	B4	B3	B2	B1	B0	
Basic Colors	Black	0	0	0	0	0	0	0	0	0	0	0	0	0	0	0	0	0	0
	Red(63)	1	1	1	1	1	1	0	0	0	0	0	0	0	0	0	0	0	0
	Green(63)	0	0	0	0	0	0	1	1	1	1	1	1	0	0	0	0	0	0
	Blue(63)	0	0	0	0	0	0	0	0	0	0	0	0	1	1	1	1	1	1
	Cyan	0	0	0	0	0	0	1	1	1	1	1	1	1	1	1	1	1	1
	Magenta	1	1	1	1	1	1	0	0	0	0	0	0	1	1	1	1	1	1
	Yellow	1	1	1	1	1	1	1	1	1	1	1	1	0	0	0	0	0	0
	White	1	1	1	1	1	1	1	1	1	1	1	1	1	1	1	1	1	1
Red	Red(00) Dark	0	0	0	0	0	0	0	0	0	0	0	0	0	0	0	0	0	0
	Red(01)	0	0	0	0	0	1	0	0	0	0	0	0	0	0	0	0	0	0
	Red(02)	0	0	0	0	1	0	0	0	0	0	0	0	0	0	0	0	0	0
	:	:	:	:	:	:	:	:	:	:	:	:	:	:	:	:	:	:	:
	Red(61)	1	1	1	1	0	1	0	0	0	0	0	0	0	0	0	0	0	0
	Red(62)	1	1	1	1	1	0	0	0	0	0	0	0	0	0	0	0	0	0
	Red(63) Bright	1	1	1	1	1	1	0	0	0	0	0	0	0	0	0	0	0	0
Green	Green(00)Dark	0	0	0	0	0	0	0	0	0	0	0	0	0	0	0	0	0	0
	Green(01)	0	0	0	0	0	0	0	0	0	0	1	0	0	0	0	0	0	0
	Green(02)	0	0	0	0	0	0	0	0	0	0	1	0	0	0	0	0	0	0
	:	:	:	:	:	:	:	:	:	:	:	:	:	:	:	:	:	:	:
	Green(61)	0	0	0	0	0	0	1	1	1	1	0	1	0	0	0	0	0	0
	Green(62)	0	0	0	0	0	0	1	1	1	1	1	0	0	0	0	0	0	0
	Green(63)Bright	0	0	0	0	0	0	1	1	1	1	1	1	0	0	0	0	0	0
Blue	Blue(00) Dark	0	0	0	0	0	0	0	0	0	0	0	0	0	0	0	0	0	0
	Blue(01)	0	0	0	0	0	0	0	0	0	0	0	0	0	0	0	0	0	1
	Blue(02)	0	0	0	0	0	0	0	0	0	0	0	0	0	0	0	0	1	0
	:	:	:	:	:	:	:	:	:	:	:	:	:	:	:	:	:	:	:
	Blue(61)	0	0	0	0	0	0	0	0	0	0	0	1	1	1	1	1	0	1
	Blue(62)	0	0	0	0	0	0	0	0	0	0	0	1	1	1	1	1	1	0
	Blue(63) Bright	0	0	0	0	0	0	0	0	0	0	0	1	1	1	1	1	1	1

Product Specification

3-6. Power Sequence

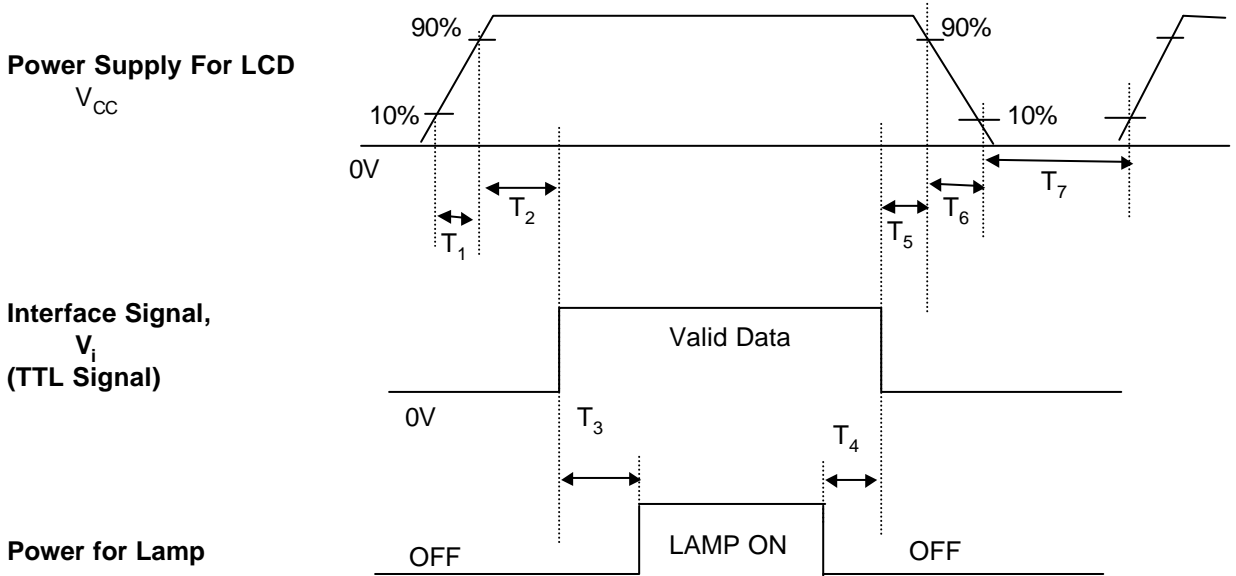

Parameter	Values			Units
	Min.	Typ.	Max.	
T_1	-	-	10	ms
T_2	0	-	50	ms
T_3	200	-	-	ms
T_4	200	-	-	ms
T_5	0	-	50	ms
T_6	-	-	10	ms
T_7	400	-	-	ms

- Notes :
1. Please avoid floating state of interface signal at invalid period.
 2. When the interface signal is invalid, be sure to pull down the power supply for LCD V_{CC} to 0V.
 3. Lamp power must be turn on after power supply for LCD and interface signal are valid.

Product Specification

4. Optical Specification

Optical characteristics are determined after the unit has been 'ON' and stable for approximately 30 minutes in a dark environment at 25 °C. The values specified are at an approximate distance 50cm from the LCD surface at a viewing angle of Φ and θ equal to 0 °.

FIG. 1 presents additional information concerning the measurement equipment and method.

FIG. 1 Optical Characteristic Measurement Equipment and Method

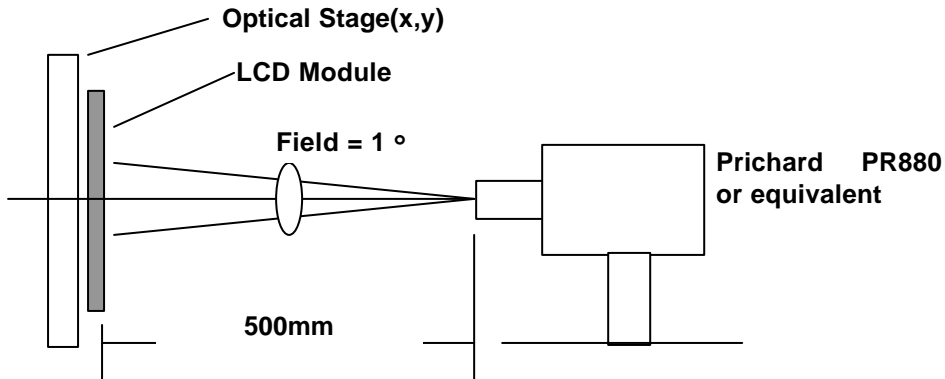

($T_a=25\text{ °C}$, $V_{CC}=3.3V$, $f_v=60Hz$
 $Dclk=25MHz$, $I_{BL}=5mA$)

Table 8. OPTICAL CHARACTERISTICS

Parameter	Symbol	Values			Units	Notes
		Min.	Typ.	Max.		
Contrast Ratio	CR	-	TBD	-		1
Surface Luminance, white	L_{WH}	160	200	-	cd/m ²	2
Luminance Variation	δ_{WHITE}	-	1.25	1.40		3
Response Time	T_r				ms	4
Rise Time	T_{rR}	-	15	30		
Decay Time	T_{rD}	-	30	50		
CIE Color Coordinates						
Red	R_x	-	TBD	-		
	R_y	-	TBD	-		
Green	G_x	-	TBD	-		
	G_y	-	TBD	-		
Blue	B_x	-	TBD	-		
	B_y	-	TBD	-		
White	W_x	-	TBD	-		
	W_y	-	TBD	-		
Viewing Angle					degree	
x axis, right($\phi=0^\circ$)	θ_r	40	45	-		5
x axis, left ($\phi=180^\circ$)	θ_l	40	45	-		
y axis, up ($\phi=90^\circ$)	θ_u	10	15	-		
y axis, down ($\phi=270^\circ$)	θ_d	30	35	-		
Gray Sclae	-	-	-	-		6

Product Specification

Notes : 1. Contrast Ratio(CR) is defined mathematically as :

$$\text{Contrast Ratio} = \frac{\text{Surface Luminance with all white pixels}}{\text{Surface Luminance with all black pixels}}$$

2. Surface luminance is the center point across the LCD surface 50cm from the surface with all pixels displaying white. For more information see FIG 2.
When $I_{BL}=5\text{mA}$, $L_{WH}=160\text{cd/m}^2(\text{Min.})$ $200\text{cd/m}^2(\text{Typ.})$
3. The variation in surface luminance, δ WHITE is determined by measuring L_{ON} at each test position 1 through 5, and then dividing the maximum L_{ON} of 5 points luminance by minimum L_{ON} of 5 points luminance. For more information see FIG 2.
$$\delta \text{ WHITE} = \text{Maximum}(L_{ON1}, L_{ON2}, \dots, L_{ON5}) \div \text{Minimum}(L_{ON1}, L_{ON2}, \dots, L_{ON5})$$
4. Response time is the time required for the display to transition from to black(Rise Time, Tr_R) and from black to white(Decay Time, Tr_D). For additional information see FIG 3.
5. Viewing angle is the angle at which the contrast ratio is greater than 5. The angles are determined for the horizontal or x axis and the vertical or y axis with respect to the z axis which is normal to the LCD surface. For more information see FIG 4.
6. Gray scale specification

Gray Level	Luminance(%) (Typ.)
L0	TBD
L7	TBD
L15	TBD
L23	TBD
L31	TBD
L39	TBD
L47	TBD
L55	TBD
L63	TBD

Product Specification

FIG. 2 Luminance

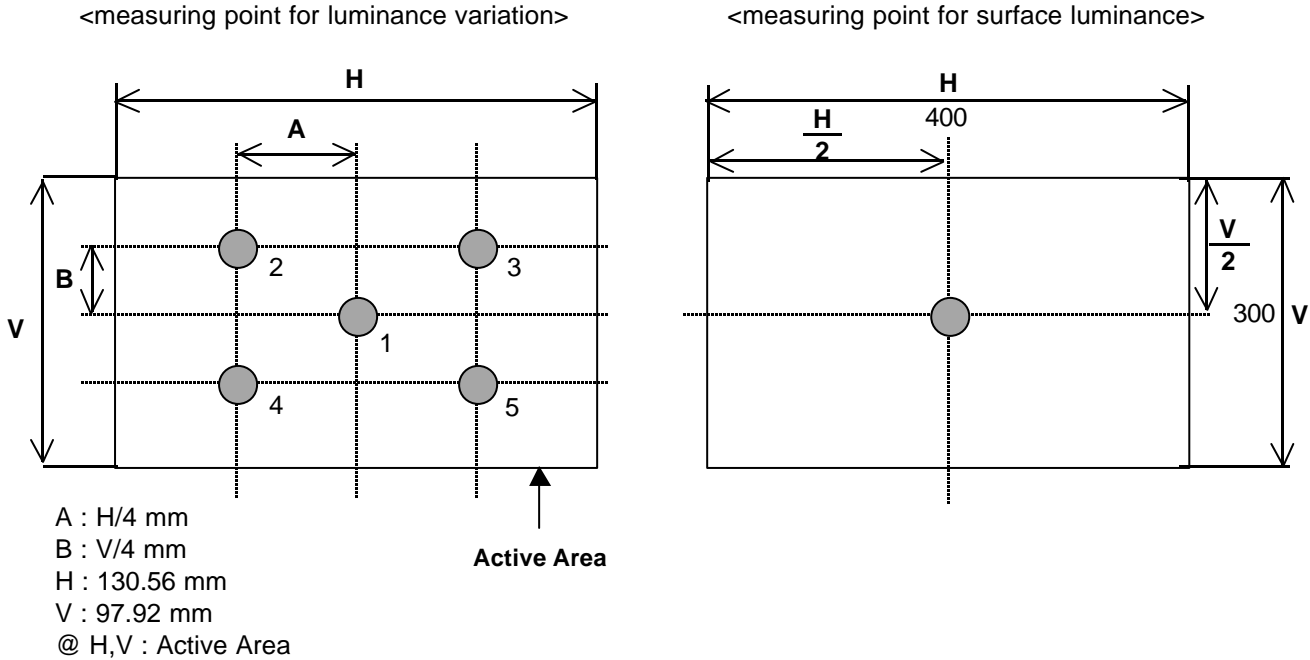
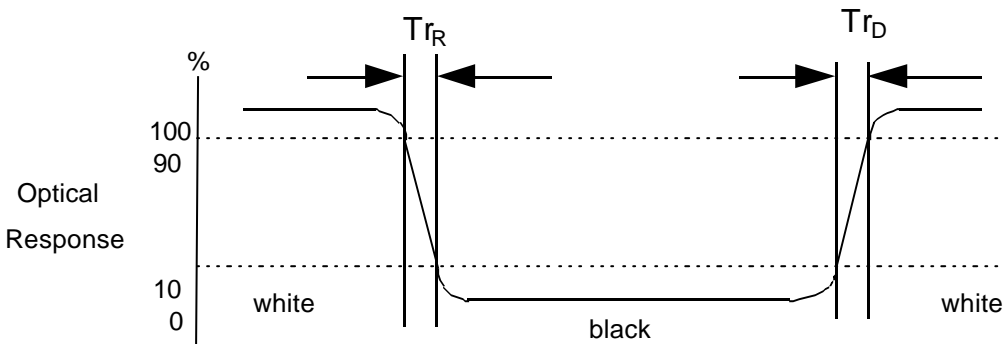

FIG. 3 Response Time

The response time is defined as the following figure and shall be measured by switching the input signal for "black" and "white".



Product Specification

FIG. 4 Viewing angle

<dimension of viewing angle range>

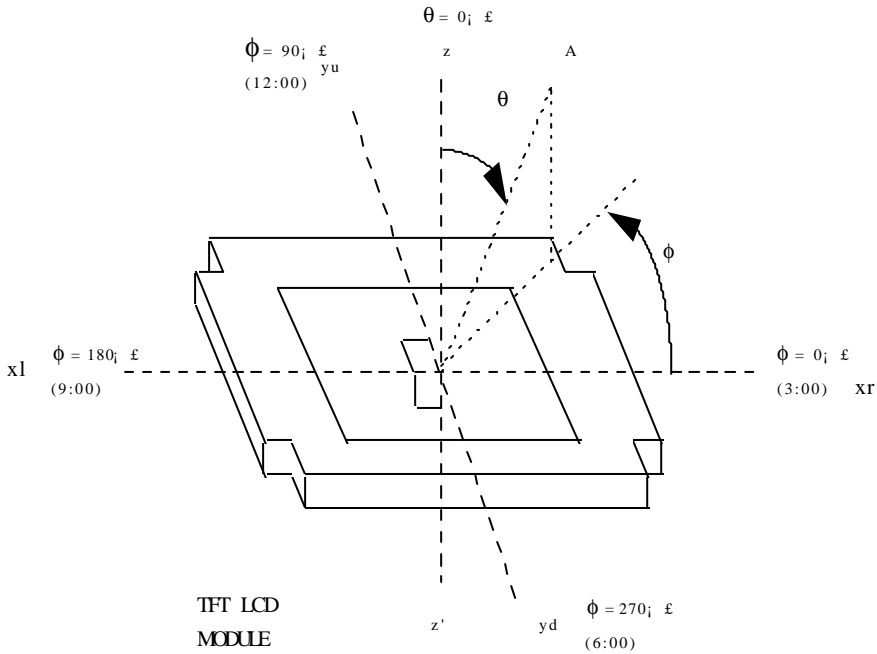

Product Specification

5. Mechanical Characteristics

The contents provide general mechanical characteristics for the model LB064V02-B1. In addition the figures in the next page are detailed mechanical drawing of the LCD.

Outside dimensions	Horizontal	145.5 ± 0.5 mm
	Vertical	111.5 ± 0.5 mm
	Depth	6.7 ± 0.3 mm
Bezel area	Horizontal	133.8 ± 0.5 mm
	Vertical	101.1 ± 0.5 mm
Active display area	Horizontal	130.56 mm
	Vertical	97.92 mm
Weight(approximate)	175g(Typ.), 185g(Max.)	
Surface Treatment	Anti-glare & Hard coating(3H)	

(... ..Spec. . Buyer, ..Biz, ... spec....
 .. BiZ.
 ..: 145g (typ.), 155g(Max)

Product Specification

<FRONT VIEW>

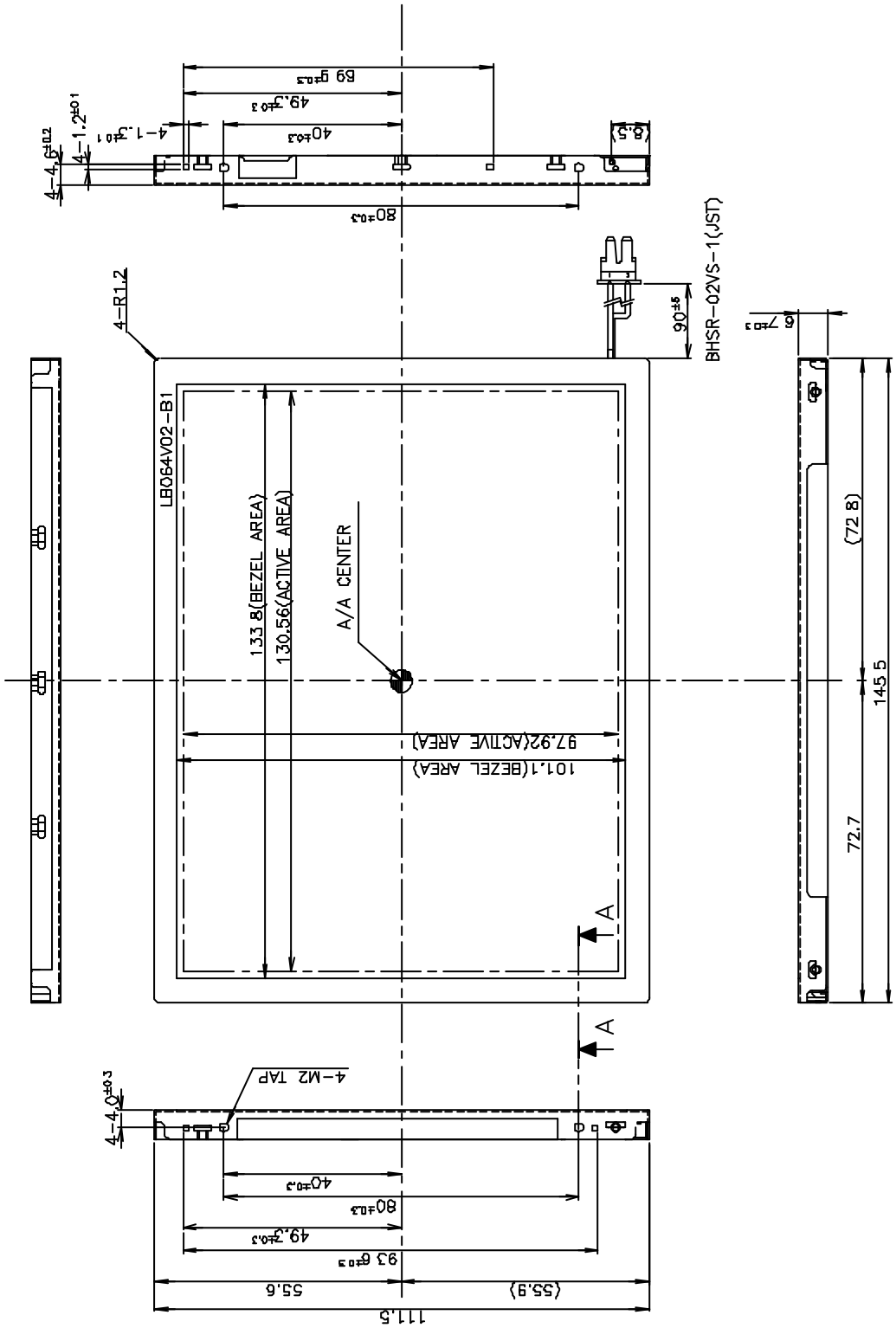

Product Specification

<REAR VIEW>

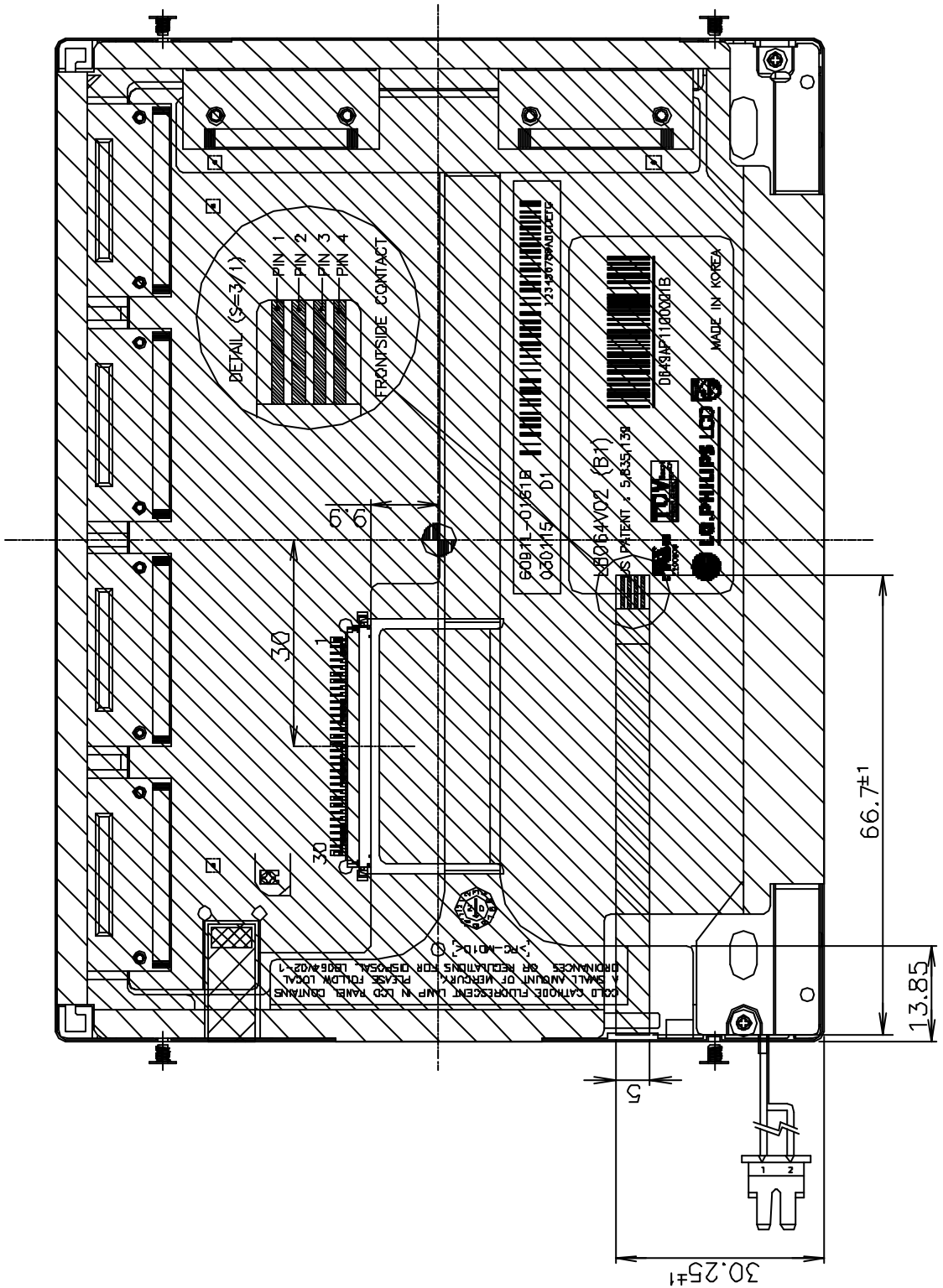

Product Specification

<DETAIL DESCRIPTION OF SIDE MOUNTING SCREW>

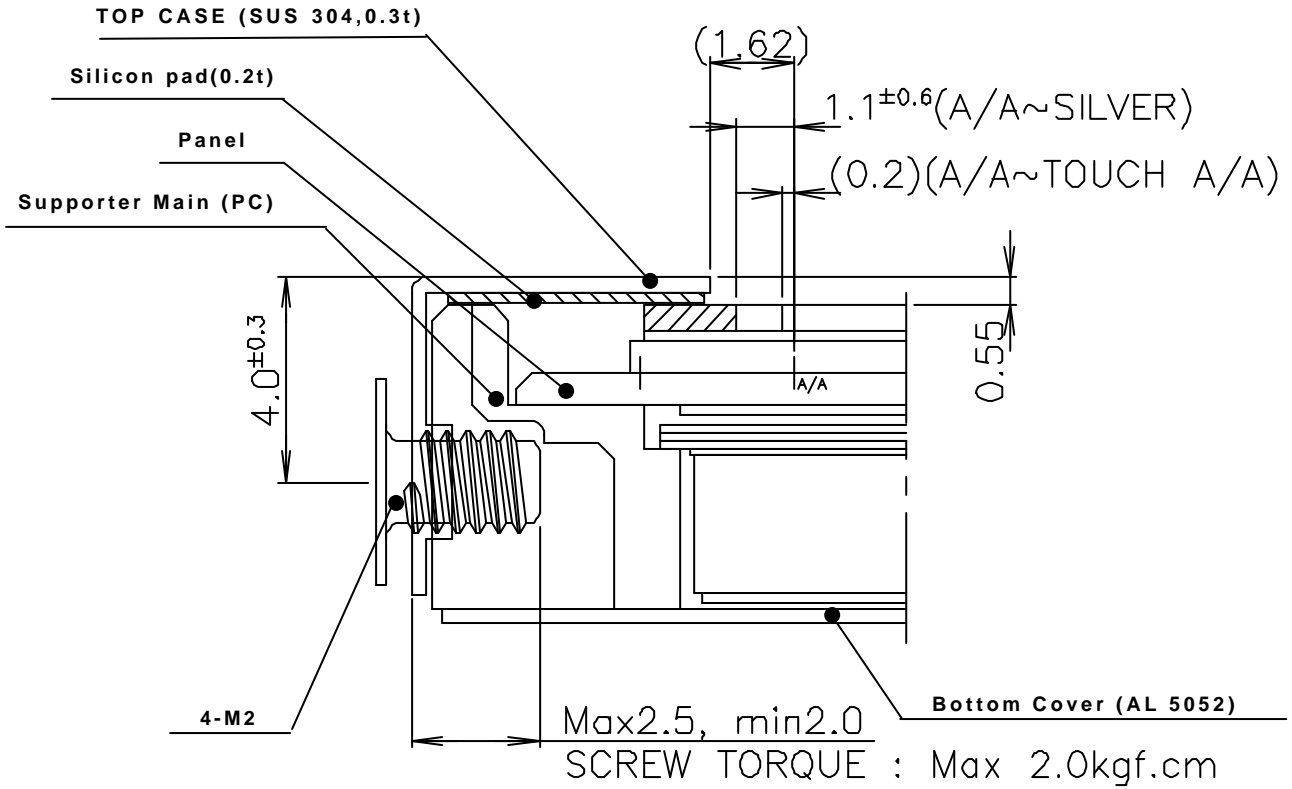

- Notes :
1. Unspecified dimensional tolerances are ± 0.3 mm.
 2. FPC size is 40mm when it is folded outward by folding align.
 3. Screw plated through the method of non-electrolytic nickel plating is preferred to reduce possibility that results in vertical and/or horizontal line defect due to the conductive particles from screw surface.

Product Specification

6. Touch Panel Characteristics

The contents provide general characteristics for the Touch Panel.

6.1 Operation Specification

Item	Min.	Typ.	Max.	Unit	Remark
Operating Voltage	-	5	-	V _{DC}	

6.2 Electrical Specification

Item	Min.	Typ.	Max.	Unit	Remark
Linearity	-1.5	-	+1.5	%	Notes 1.
Terminal Resistance	R _X	250	400	550	
	R _Y	150	300	450	
Insulation Resistance	25	-	-	·	@ DC 25V
Chattering Time	-	-	10	·	@ 100 · pull-up

6.3 Mechanical Specification

Item	Spec.	Remark
Input Method	Finger or Stylus*	* Stylus : R0.8 Polyacetal pen
Activation Force	80g or less	
Surface Hardness	3H or more	According to JIS-K5400

Product Specification

6.4 Durability

Item	Min.	Typ.	Max.	Unit	Remark
Hitting Life	1,000,000	-	-		250gf, 2times/sec, R0.8(Stylus) or R8.0(Silicon Rubber)
Sliding Life	.*	100,000	-	-	250gf, 60mm/sec, R0.8(Stylus)
	.*	40,000	-	-	
	.*	-	-	40,000	
Tail Peeling Strength	500	-	-	g/.	

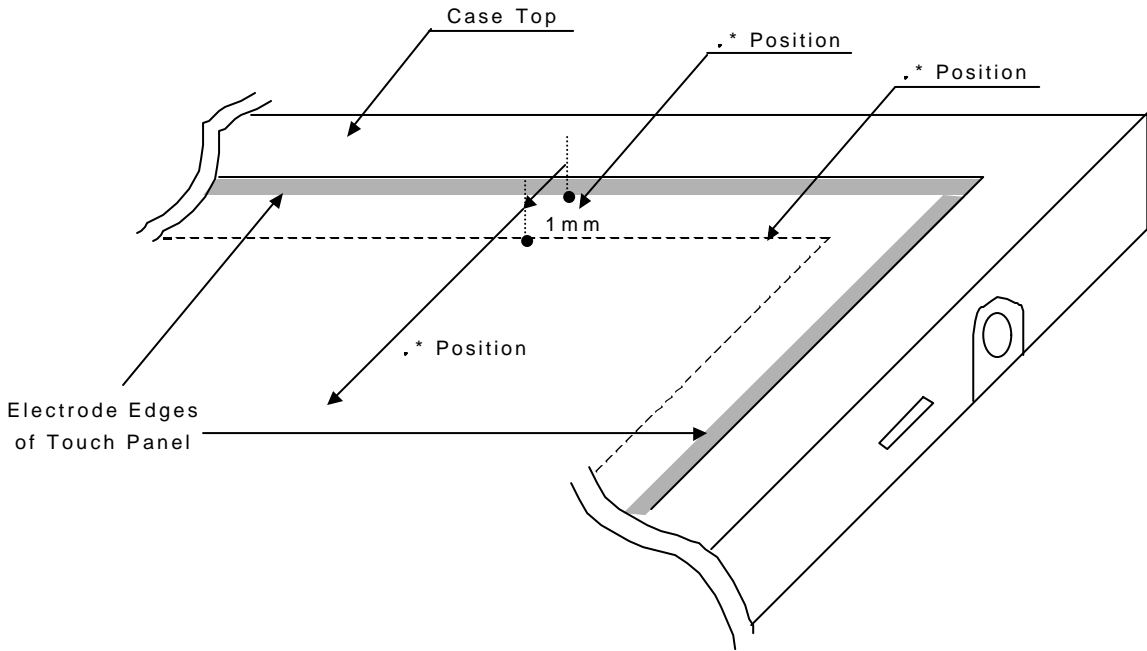

Product Specification

Notes : 1. Linearity

1. Impress DC 5V to X-directional electrode.
2. Press on the film from start-point(a) to end- point(b)
3. Detect the output voltages from Y-directional electrode.
4. As the same way, switching the connection of X & Y.

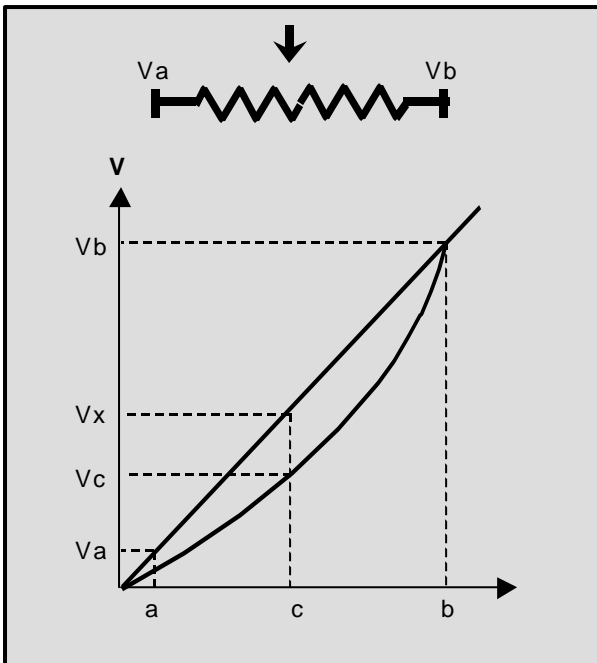
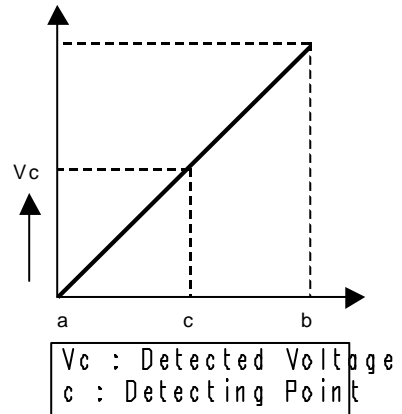
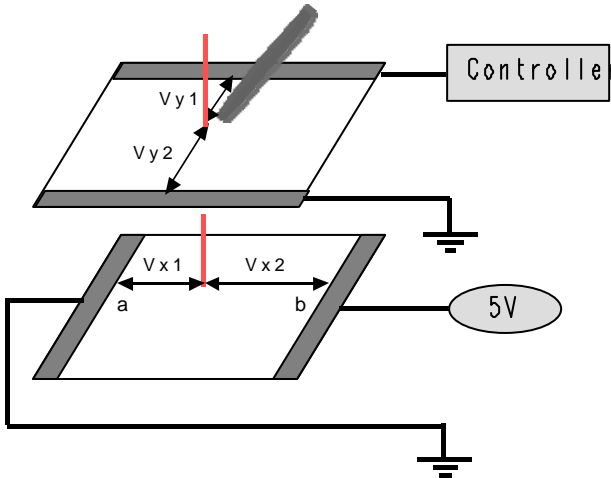

- Va : Starting point voltage
- Vb : Ending point voltage
- a : Starting point
- b : Ending point
- c : Measuring point
- Vc : Measured voltage of c
- Vx : Expecting voltage of c

$$\text{Linearity}[\%] = \frac{[Vx - Vc] \times 100}{Vb - Va}$$

Product Specification

7. Reliability

Environment test condition

TBD

No.	Test Item	Conditions
1	High temperature storage test	Ta= 60°C 240h
2	Low temperature storage test	Ta= -20°C 240h
3	High temperature operation test	Ta= 50°C 50%RH 240h
4	Low temperature operation test	Ta= 0°C 240h
5	Vibration test (non-operating)	Sine wave, 10 ~ 500 ~ 10Hz, 1.5G, 0.37oct/min 3 axis, 1hour/axis
6	Shock test (non-operating)	Half sine wave, 180G, 2ms one shock of each six faces(I.e. run 180G 2ms for all six faces)
7	Altitude operating storage / shipment	0 - 10,000 feet(3048m) 0 - 40,000 feet(12,192m)

{ Result Evaluation Criteria }

There should be no change which might affect the practical display function when the display quality test is conducted under normal operating condition.

Product Specification

8. International Standards

8-1. Safety

- a) UL 1950 Third Edition, Underwriters Laboratories, Inc. Jan. 28, 1995.
Standard for Safety of Information Technology Equipment Including Electrical Business Equipment.
- b) CAN/CSA C22.2 No. 950-95 Third Edition, Canadian Standards Association, Jan. 28, 1995.
Standard for Safety of Information Technology Equipment Including Electrical Business Equipment.
- c) EN 60950 : 1992+A1: 1993+A2: 1993+A3: 1995+A4: 1997+A11: 1997
IEC 950 : 1991+A1: 1992+A2: 1993+A3: 1995+A4: 1996
European Committee for Electrotechnical Standardization(CENELEC)
EUROPEAN STANDARD for Safety of Information Technology Equipment Including Electrical Business Equipment.

8-2. EMC

- a) ANSI C63.4 "Methods of Measurement of Radio-Noise Emissions from Low-Voltage Electrical and Electrical Equipment in the Range of 9kHz to 40GHz. "American National Standards Institute(ANSI), 1992
- b) C.I.S.P.R "Limits and Methods of Measurement of Radio Interface Characteristics of Information Technology Equipment." International Special Committee on Radio Interference
- c) EN 55022 "Limits and Methods of Measurement of Radio Interface Characteristics of Information Technology Equipment." European Committee for Electrotechnical Standardization (CENELEC), 1998

Product Specification

9. Packing

9-1. Designation of Lot Mark

a) Lot Mark

A	B	C	D	E	F	G	H	I	J	K	L	M
---	---	---	---	---	---	---	---	---	---	---	---	---

A,B,C : SIZE

D : YEAR

E : MONTH

F,G : PANEL CODE

H : ASSEMBLY CODE

I,J,K,L,M : SERIAL NO.

Note:

1. YEAR

YEAR	97	98	99	2000	2001	2002	2003	2004	2005	2006	2007
Mark	7	8	9	0	1	2	3	4	5	6	7

2. MONTH

MONTH	Jan.	Feb.	Mar.	Apr.	May.	Jun.	Jul.	Aug.	Sep.	Oct.	Nov.	Dec.
Mark	1	2	3	4	5	6	7	8	9	10	11	12

b) Location of Lot Mark

Serial NO. is printed on the label. The label is attached to the backside of the LCD module.
 This is subject to change without prior notice.

9-2. Packing Form

a) Package quantity in one box : 20 pcs

b) Box Size : 325mm X 271mm X 197mm

Product Specification

10. PRECAUTIONS

Please pay attention to the following when you use this TFT LCD module.

10-1. MOUNTING PRECAUTIONS

- (1) You must mount a module using holes arranged in four corners or four sides.
- (2) You should consider the mounting structure so that uneven force(ex. Twisted stress) is not applied to the module.
And the case on which a module is mounted should have sufficient strength so that external force is not transmitted directly to the module.
- (3) Do not hold Tail of touch panel on handling a module.
- (4) Always handle the outside of module's active area.
- (5) Please attach a transparent protective film(< 0.15mm) to the surface in order to protect the touch panel.
Transparent protective plate should have sufficient strength in order to the resist external force.
- (6) You should adopt radiation structure to satisfy the temperature specification.
- (7) Acetic acid type and chlorine type materials for the cover case are not describe because the former generates corrosive gas of attacking the touch panel at high temperature and the latter causes circuit break by electro-chemical reaction.
- (8) Do not touch, push or rub the exposed touch panel with glass, tweezers or anything harder than 3H pencil lead. And please do not rub with dust clothes with chemical treatment.
- (9) When the surface becomes dusty, please wipe gently with absorbent cotton or other soft materials soaks with alcohol based products. IPA, acetone, methanol and toluene are recommended for cleaning the adhesives used to attach front touch panel and rear polarizer.
Do not use bleach based products because they cause chemical damage to the touch panel and polarizer.
- (10) Wipe off saliva or water drops as soon as possible. Their long time contact with touch panel and polarizer causes deformations and color fading.
- (11) Do not open the case because inside circuits do not have sufficient strength.
- (12) If there are some problems by using system bracket, system bracket should be first modified and then LCD module reconfirmed under mutual approval .

10-2. OPERATING PRECAUTIONS

- (1) The spike noise causes the mis-operation of circuits. It should be lower than following voltage :
 $V = \pm 200\text{mV}$ (Over and under shoot voltage)
- (2) Response time depends on the temperature.(In lower temperature, it becomes longer.)
- (3) Brightness depends on the temperature. (In lower temperature, it becomes lower.)
And in lower temperature, response time(required time that brightness is stable after turned on) becomes longer.
- (4) Be careful for condensation at sudden temperature change. Condensation makes damage to touch panel, polarizer or electrical contacted parts.
And after fading condensation, smear or spot will occur.
- (5) When fixed patterns are displayed for a long time, remnant image is likely to occur.
- (6) Module has high frequency circuits. Sufficient suppression to the electromagnetic interference shall be done by system manufacturers. Grounding and shielding methods may be important to minimized the interference.

Product Specification

- (7) Use a "Finger" or "Stylus Pen(Polyacetal tip)" when operating.
- (8) The terminal resistance of the analog resistive touch screen varies by the individual, time and environment. The controller software must have the calibration function to adjust the input position and the display position.
- (9) Be careful not to press entire display so hard, especially edge area of display.
- (10) The Touch Sensor may not be activated by weak touch and force.

10-3. ELECTROSTATIC DISCHARGE CONTROL

Since a module is composed of electronic circuits, it is not strong to electrostatic discharge. Make certain that treatment persons are connected to ground through wrist band etc. And don't touch interface pin directly.

10-4. PRECAUTIONS FOR STRONG LIGHT EXPOSURE

Strong light exposure causes degradation of touch panel and color filter.

10-5. STORAGE

When storing modules as spares for a long time, the following precautions are necessary.

- (1) Store them in a dark place. Do not expose the module to sunlight or fluorescent light. Keep the temperature between 5 °C and 35 °C at normal humidity.
- (2) The touch panel surface should not come in contact with any other object.
It is recommended that they be stored in the container in which they were shipped.

10-6. HANDLING PRECAUTIONS FOR PROTECTION FILM

- (1) When the protection film is peeled off, static electricity is generated between the film and touch panel. This should be peeled off slowly and carefully by people who are electrically grounded and with well ion-blown equipment or in such a condition, etc.
- (2) The protection film is attached to the touch panel with a small amount of glue. If some stress is applied to rub the protection film against the touch panel during the time you peel off the film, the glue is apt to remain on the touch panel.
Please carefully peel off the protection film without rubbing it against the touch panel.
- (3) When the module with protection film attached is stored for a long time, sometimes there remains a very small amount of glue still on the touch panel after the protection film is peeled off.
- (4) You can remove the glue easily. When the glue remains on the touch panel surface or its vestige is recognized, please wipe them off with absorbent cotton waste or other soft material like chamois soaked with normal-hexane.

Product Specification

11. IIS (Incoming Inspection Standard)

11.1. Inspection Method

11.1.1. Ambient conditions

- a. Temperature : 20~25
- b. Humidity : 65 ± 5 % RH
- c. Illumination : Single 20W fluorescent lamp non-directive
(300 to 700 Lux)

11.1.2. Viewing distance

The distance between the LCM and the inspector's eyes shall be at least 30-50Cm.

11.1.3. Viewing Angle

The inspection shall be conducted within normal viewing angle range.
 . Refer to 16pages for viewing angle.

11.1.4. Measurement mode

Inspection method is based on transmissive mode only.

11.2 Inspection Criteria

11.2.1. Dot Defect

11.2.1.1. Bright Dot

Dots(sub-pixels) which appeared brightly in the screen when the LCM displayed with dark pattern.

- R,G or B 1 dot ----- 4 Max
- Adjacent 2 dots ----- 1 Max
- Total amount of Bright dots ----- 4 Max
- Minimum Distance between bright dots ----- Within , 20 mm, Max 2

11.2.1.2. Dark Dot

Dots(sub-pixels) which appeared darkly in the screen when the LCM displayed with bright pattern.

- 1 dot ----- 4 Max
- Adjacent 2 dots ----- 1 Max
- Total amount of Dark dot ----- 4 Max
- Minimum Distance between dark dots ----- Within , 20 mm, Max 2

11.2.1.3. Total amount of Dot Defects ----- 8 Max(Combination)

- Note) a. Every dot herein means Sub-Pixel(Each Red,Green, or Blue Color)
 b. Bright & Dark dots are larger than half sub-pixel.
 (Dots smaller than half sub-pixel are not counted as a defect dots.)

Product Specification

11.3. Touch Panel and Polarizer Defects

Items		Criteria
Scratches	Linear	$W < 0.05$ and $L < 5$
Dent	Circular	$0.2 < D < 0.5$, $n < 4$, $0.5 < D < 1.0$, $n < 1$

Note)

a. Average Diameter

$$D = \frac{a+b}{2}$$

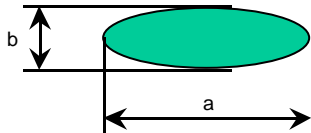

W : Width
L : Length
D : Average diameter
n : Number of Defects

b. Linear : $a < 2b$, Circular : $a < 2b$

c. Extraneous substances which can be wiped out, like Finger Print, Particles, are not considered as a defect.

d. Defects which is on the Black Matrix(outside of Active Area) are not considered as a defect.

11.4 Foreign Material (including Touch Panel and Polarizer)

Items		Criteria
Foreign Material (Bright & Gray)	Linear	$0.05 < W < 0.07$ and $L < 3.0$, $N < 11$, $n < 2$
	Circular	$0.35 < D < 0.50$, $\phi < 20\text{mm}$, $n < 3$

Note)

a. Average Diameter

$$D = \frac{a+b}{2}$$

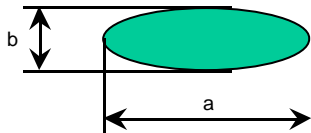

W : Width
L : Length
D : Average diameter
n : Number of Foreign Material
N : Number of Pixels on which Foreign Material resides
φ : Distance of Other Foreign Material

b. Linear : $a < 2b$, Circular : $a < 2b$

c. In case of Linear Foreign Material, both length(L) and number of pixels(N) are used as criteria for the sake of inspection convenience.

d. The distance between inspector's eyes and screen is 30cm(11.8inch)

11.5. Line Defect

All kinds of line defects such as vertical, horizontal or cross are not allowed.

11.6. Bezel Appearance

Scratches, minor bents, stains, particles on the Bezel frame are not considered as a defect.

Electrodes and Laser Etching Vestiges of touch panel are not considered as a defect unless they encroach on the active area of LCD.

11.7. Others

Issues which is not defined in this criteria shall be discussed with both parties, Customer and Supplier, for better solution.