

**DATA DISPLAY AG**

**LC151X01-C3  
15.1" XGA TFT LCD**

**PRELIMINARY  
SPECIFICATION**

The information given in this document is carefully checked and believed to be reliable. LG.PHILIPS reserves the right to make changes in product or specification at any time and without further notice. LG.PHILIPS products are not intended for use in systems in which failures of product could result in personal injury. All mentioned trademarks are registered trademarks of their owner.

Ver. 0.1 Jan. 18, 2002

Product Specification

Contents

No	ITEM	Page
	COVER	1
	CONTENTS	2
	RECORD OF REVISIONS	3
1	GENERAL DESCRIPTION	4
2	ABSOLUTE MAXIMUM RATINGS	5
3	ELECTRICAL SPECIFICATIONS	6
3-1	ELECTRICAL CHARACTREISTICS	7
3-2	INTERFACE CONNECTIONS	8
3-3	SIGNAL TIMING SPECIFICATIONS	10
3-4	SIGNAL TIMING WAVEFORMS	11
3-5	COLOR INPUT DATA REFERNECE	12
3-6	POWER SEQUENCE	13
4	OPTICAL SFECIFICATIONS	14
5	MECHANICAL CHARACTERISTICS	18
6	RELIABLITY	21
7	INTERNATIONAL STANDARDS	22
7-1	SAFETY	22
7-2	EMC	22
8	Packing	23
8-1	DESIGNATION OF LOT MARK	23
8-2	Packing FORM	23
9	PRECAUTIONS	24



Product Specification

## 1. General Description

The LC151X01 is a Color Active Matrix Liquid Crystal Display with an integral Cold Cathode Fluorescent Lamp(CCFL) backlight system. The matrix employs a-Si Thin Film Transistor as the active element. It is a transmissive type display operating in the normally white mode. This TFT-LCD has a 15.1 inch diagonally measured active display area with XGA resolution (768 vertical by 1024 horizontal pixel array) Each pixel is divided into Red, Green and Blue sub-pixels or dots which are arranged in vertical stripes. Gray scale or the brightness of the sub-pixel color is determined with a 8-bit gray scale signal for each dot, thus, presenting a palette of more than 16,2M colors with 6Bit FRC algorithm.

The LC151X01 has been designed to apply the 8Bit LVDS interface.

The LC151X01 is intended to support LCD TV, PCTV where high brightness, wide viewing angle, high color saturation, and high color are important.

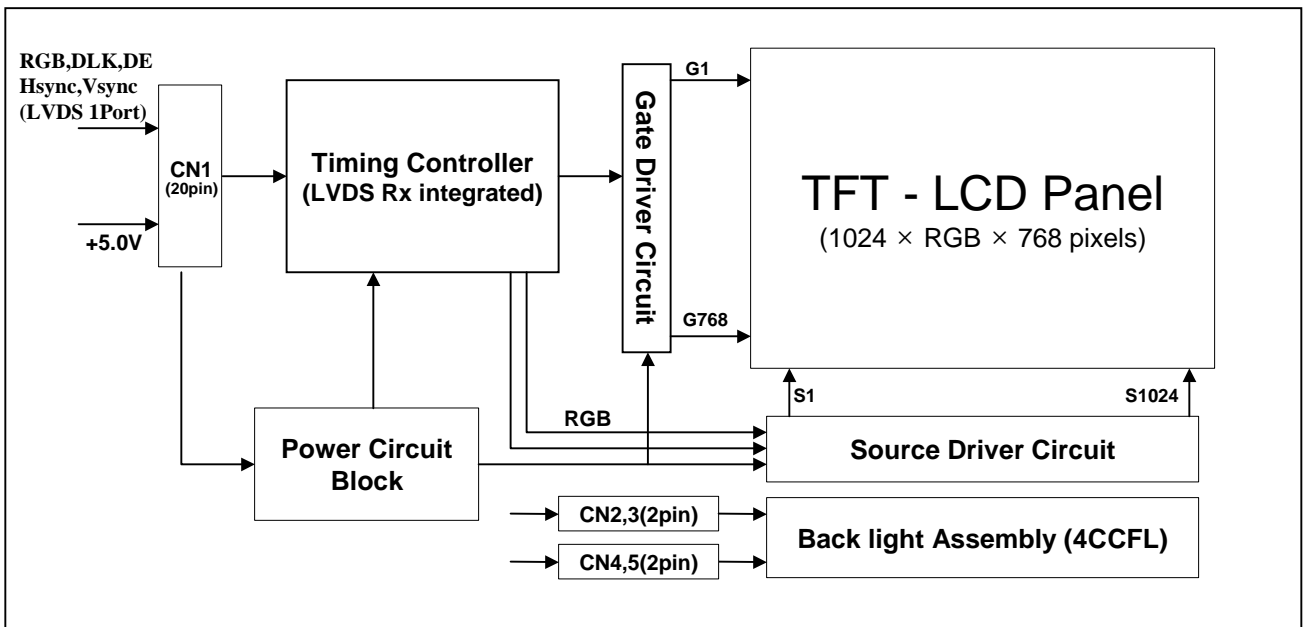

## General Features

Active Screen Size	15.1 inches(38.4cm) diagonal
Outline Dimension	352(H) x 263.5(V) x 18.0(D) mm(Typ.)
Pixel Pitch	0.300mm x 0.300mm
Pixel Format	1024 horiz. By 768 vert. Pixels RGB strip arrangement
Color Depth	6bit FRC algorithm, 16,2 M colors
Luminance, White	400 cd/m <sup>2</sup> (Center 1 points typ.)
Power Consumption	Total 18.7 Watt(Typ.)
Weight	1,750 g (typ.)
Display Operating Mode	Transmissive mode, normally white
Surface Treatment	Hard coating(3H) Anti-glare(Haze 13%) treatment of the front polarizer,

Product Specification

2. Absolute Maximum Ratings

The following are maximum values which, if exceeded, may cause faulty operation or damage to the unit.

Table 1. ABSOLUTE MAXIMUM RATINGS

Parameter	Symbol	Values		Units	Notes
		Min	Max		
Power Input Voltage	Vcc	-0.3	5.8	Vdc	at 25 ± 3°C
Operating Temperature	TOP	0	50	°C	1
Storage Temperature	HST	-20	60	°C	1
Operating Ambient Humidity	HOP	10	90	%RH	1
Storage Humidity	HST	10	90	%RH	1

Note : 1. Temperature and relative humidity range are shown in the figure below.  
Wet bulb temperature should be 39 °C Max, and no condensation of water.

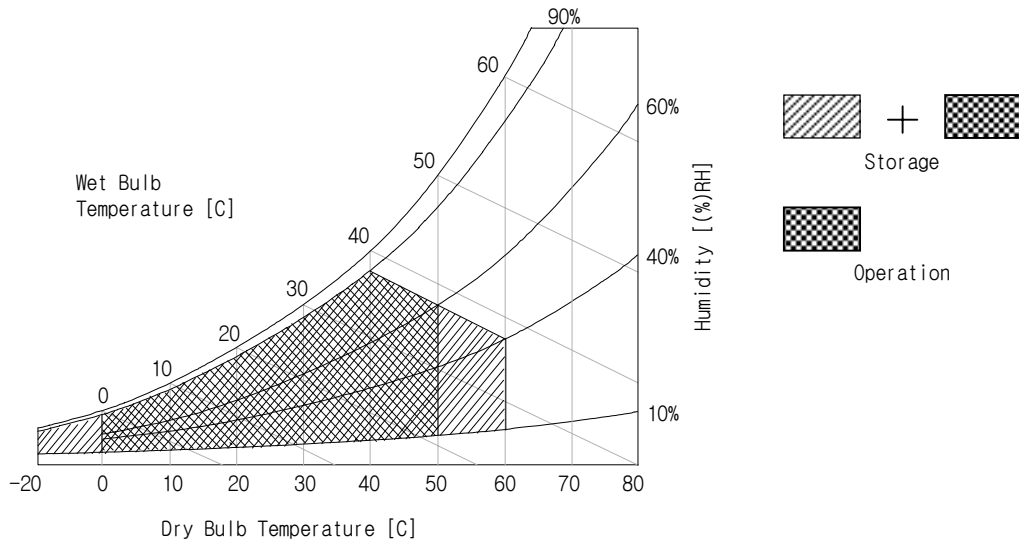

## Product Specification

### 3. Electrical Specifications

#### 3-1. Electrical Characteristics

The LC151X01 requires two power inputs. One is employed to power the LCD electronics and to drive the TFT array and liquid crystal. The second input power for the CCFL, is typically generated by an inverter. The inverter is an external unit to the LCDs.

**Table 2. ELECTRICAL CHARACTERISTICS**

Parameter	Symbol	Values			Unit	Notes
		Min	Typ	Max		
MODULE :						
Power Supply Input Voltage	V <sub>CC</sub>	4.5	5.0	5.5	V <sub>dc</sub>	
Power Supply Input Current	I <sub>CC</sub>	272	320	370	mA	1
Power Consumption	P <sub>c</sub>	1.26	1.35	1.4	Watt	1
Rush current	I <sub>RUSH</sub>	-	-	3.0	A	3
LAMP :						
Operating Voltage	V <sub>BL</sub>	520(9mA)	540(8mA)	660(3mA)	V <sub>RMS</sub>	4
Operating Current	I <sub>BL</sub>	3.0	8.0	9.0	mA	
Established Starting Voltage	V <sub>s</sub>					5
at 25 °C				900	V <sub>RMS</sub>	
at 0 °C				1170	V <sub>RMS</sub>	
Operating Frequency	f <sub>BL</sub>	50	60	70	kHz	4
Discharge Stabilization Time	T <sub>s</sub>			3	Min	7
Power Consumption	P <sub>BL</sub>		17.3	19.0	Watt	6
Life Time		50,000			Hrs	7

Note : The design of the inverter must have specifications for the lamp in LCD Assembly.

The performance of the Lamp in LCM, for example life time or brightness, is extremely influenced by the characteristics of the DC-AC inverter. So all the parameters of an inverter should be carefully designed so as not to produce too much leakage current from high-voltage output of the inverter. When you design or order the inverter, please make sure unwanted lighting caused by the mismatch of the lamp and the inverter(no lighting, flicker, etc) never occurs. When you confirm it, the LCD – Assembly should be operated in the same condition as installed in you instrument.

1. The specified current and power consumption are under the V<sub>CC</sub>=5.0V, 25°C, f<sub>V</sub>=60Hz condition whereas mosaic pattern(8 x 6) is displayed and f<sub>V</sub> is the frame frequency.

2. This impedance value is needed to proper display and measured from TMDST<sub>X</sub> to the mating connector.

3. The duration of rush current is about 2ms and rising time of Power Input is 1ms(min.).

4. The variance of the voltage is ± 10%.

5. The voltage above V<sub>S</sub> should be applied to the lamps for more than 1 second for start-up.

Otherwise, the lamps may not be turned on. The used lamp current is the lamp typical current.

Product Specification

6. The output of the inverter must have symmetrical(negative and positive) voltage waveform and symmetrical current waveform.(Unsymmetrical ratio is less than 10%) Please do not use the inverter which has unsymmetrical voltage and unsymmetrical current and spike wave.  
Lamp frequency may produce interface with horizontal synchronous frequency and as a result this may cause beat on the display. Therefore lamp frequency shall be as away possible from the horizontal synchronous frequency and from its harmonics in order to prevent interference.
7. Let's define the brightness of the lamp after being lighted for 5 minutes as 100%.  
 $T_S$  is the time required for the brightness of the center of the lamp to be not less than 95%.
8. The lamp power consumption shown above does not include loss of external inverter.  
The used lamp current is the lamp typical current.
9. The life is determined as the time at which brightness of the lamp is 50% compared to that of initial value at the typical lamp current on condition of continuous operating at  $25 \pm 2^\circ\text{C}$ .
10. Requirements for a system inverter design, which is intended to have a better display performance, a better power efficiency and a more reliable lamp, are following.  
It shall help increase the lamp lifetime and reduce leakage current.
- The asymmetry rate of the inverter waveform should be less than 10%.
  - The distortion rate of the waveform should be within  $\sqrt{2} \pm 10\%$ .
- \* Inverter output waveform had better be more similar to ideal sine wave.

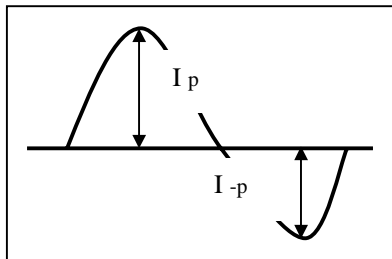

\* Asymmetry rate:

$$|I_p - I_{-p}| / I_{rms} * 100\%$$

\* Distortion rate

$$I_p \text{ (or } I_{-p}) / I_{rms}$$

- ※ Do not attach a conducting tape to lamp connecting wire.  
If the lamp wire attach to a conducting tape, TFT-LCD Module has a low luminance and the inverter has abnormal action. Because leakage current is occurred between lamp wire and conducting tape.

Product Specification

### 3-2. Interface Connections

- LCD Connector (CN1) : DF14H-20P-1.25H (Hirose)
- Mating Connector : DF14H-20S-1.25H

**Table 3-1. MODULE CONNECTOR(CN1) PIN CONFIGURATION**

Pin No	Symbol	Description	Polarity	Output Pin # (LVDS Tx)
1	VDD	Power Supply +5.0V		
2	VDD	Power Supply +5.0V		
3	GND	Power Ground.		
4	GND	Power Ground		
5	RXIN0-	LVDS Receiver Signal(-)	Negative	PIN#48
6	RXIN0+	LVDS Receiver Signal(+)	Positive	PIN#47
7	GND	Ground		
8	RXIN1-	LVDS Receiver Signal(-)	Negative	PIN#46
9	RXIN1+	LVDS Receiver Signal(+)	Positive	PIN#45
10	GND	Ground		
11	RXIN2-	LVDS Receiver Signal(-)	Negative	PIN#42
12	RXIN2+	LVDS Receiver Signal(+)	Positive	PIN#41
13	GND	Ground		
14	RXCLK IN-	LVDS Receiver Clock Signal(-)	Negative	PIN#40
15	RXCLK IN+	LVDS Receiver Clock Signal(+)	Positive	PIN#39
16	GND	Ground		
17	RXIN3-	LVDS Receiver Signal(-)	Negative	PIN#38
18	RXIN3+	LVDS Receiver Signal(+)	Positive	PIN#37
19	GND	Ground		
20	NC	Reserved		

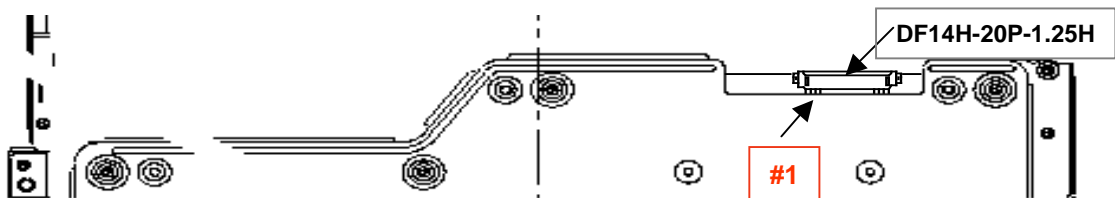

- Note:
1. All GND(ground) pins should be connected together and to Vss which should also be connected to the LCD's metal frame.
  2. All Vcc (power input) pins should be connected together.

Product Specification

**Table 4. BACKLIGHT CONNECTOR PIN CONFIGURATION(CN2,CN3,CN4,CN5)**

Connector (CN2, CN3, CN4, CN5)

CN.	Pin	Symbol	Description	Notes
CN2	1	HV	Power supply for lamp (high ),White,	1) LCD : BHSR-02VS-1 (JST) 2) System : SM02B-BHSS-1 (JST)
	2	LV	Power supply for lamp (Low) ,Black	
CN3	1	HV	Power supply for lamp (high ),Pink	
	2	LV	Power supply for lamp (Low) ,Pink	
CN4	1	HV	Power supply for lamp (high ),White,	
	2	LV	Power supply for lamp (Low) ,Black	
CN5	1	HV	Power supply for lamp (high ),Pink	
	2	LV	Power supply for lamp (Low) ,Pink	

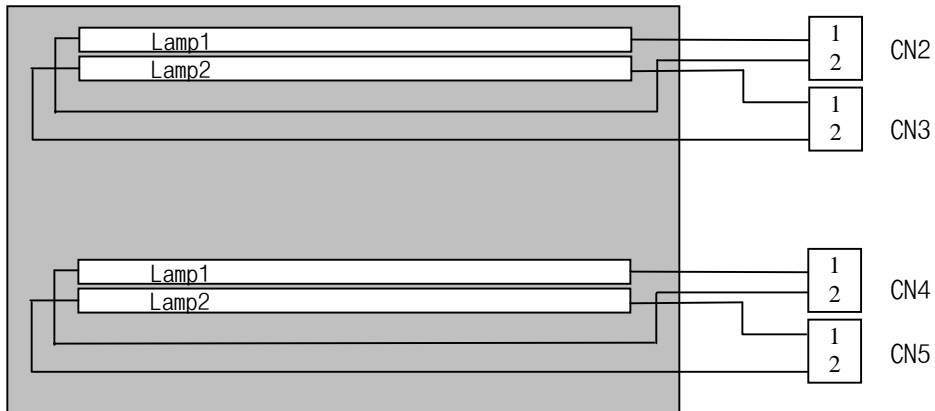

Product Specification

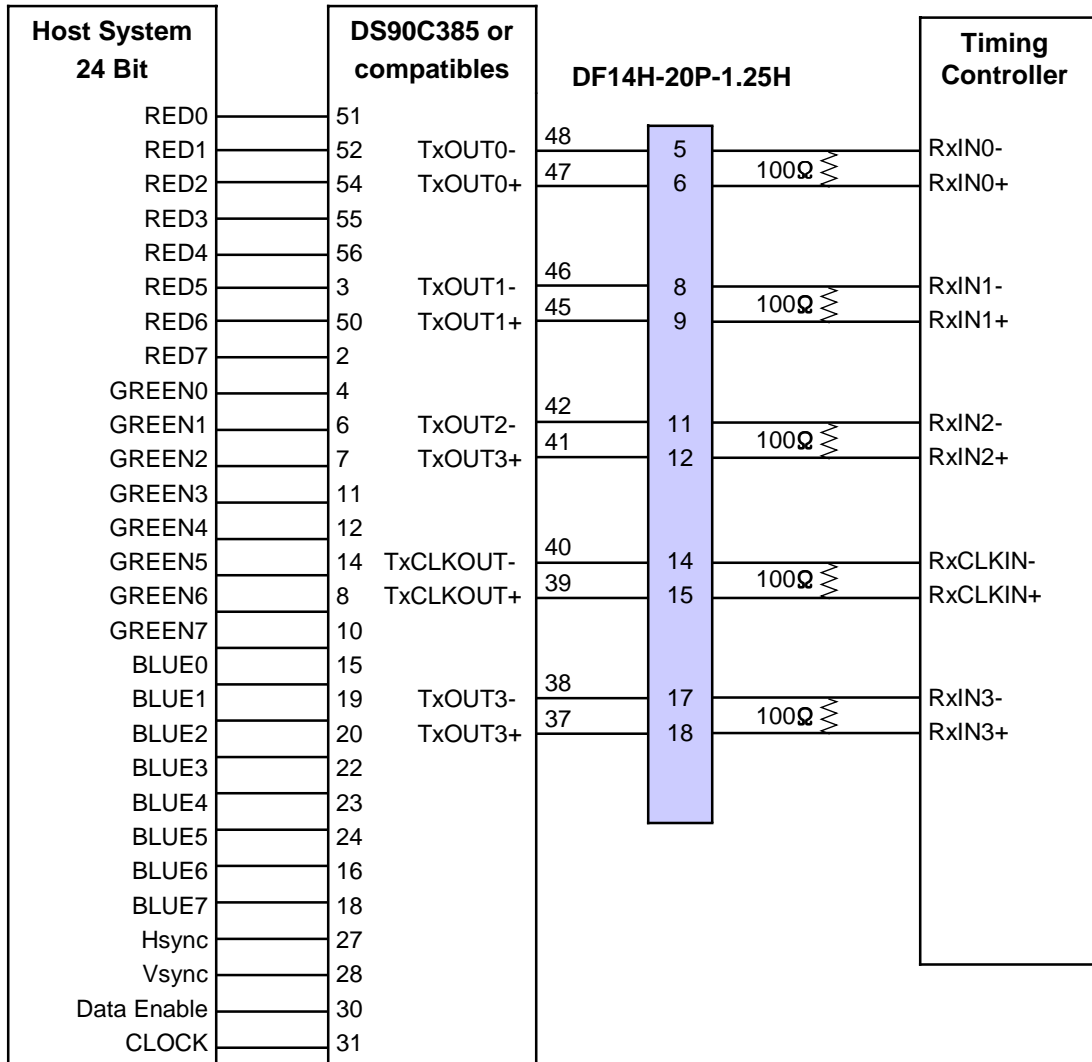

Note : The LCD Module uses a 100Ohm resistor between positive and negative lines of each receiver input.

## Product Specification

**Table 5. REQUIRED SIGNAL ASSIGNMENT FOR LVDS Transmitter**

Pin #	Pin Name	Symbol	Description	Output
51	TxIN0	Red0 [LSB]	Red Pixel Data	Rx0- Rx0+
52	TxIN1	Red1	Red Pixel Data	
54	TxIN2	Red2	Red Pixel Data	
55	TxIN3	Red3	Red Pixel Data	
56	TxIN4	Red4	Red Pixel Data	
2	TxIN5	Red7 [MSB]	Red Pixel Data	Rx3- Rx3+
3	TxIN6	Red5	Red Pixel Data	Rx0- Rx0+
4	TxIN7	Green0 [LSB]	Green Pixel Data	
6	TxIN8	Green1	Green Pixel Data	Rx1- Rx1+
7	TxIN9	Green2	Green Pixel Data	
8	TxIN10	Green6	Green Pixel Data	Rx3- Rx3+
10	TxIN11	Green7 [MSB]	Green Pixel Data	
11	TxIN12	Green3	Green Pixel Data	
12	TxIN13	Green4	Green Pixel Data	Rx1- Rx1+
14	TxIN14	Green5	Green Pixel Data	
15	TxIN15	Blue0 [LSB]	Blue Pixel Data	
16	TxIN16	Blue6	Blue Pixel Data	Rx3- Rx3+
18	TxIN17	Blue7 [MSB]	Blue Pixel Data	
19	TxIN18	Blue1	Blue Pixel Data	Rx1- Rx1+
20	TxIN19	Blue2	Blue Pixel Data	Rx2- Rx2+
22	TxIN20	Blue3	Blue Pixel Data	
23	TxIN21	Blue4	Blue Pixel Data	
24	TxIN22	Blue5	Blue Pixel Data	
25	TxIN23	RES		Rx3- Rx3+
27	TxIN24	Hsync.	No connection, If unnecessary	Rx2- Rx2+
28	TxIN25	Vsync.	No connection, If unnecessary	
30	TxIN26	EN	Data Enable	
50	TxIN27	Red6	Red Pixel Data	Rx3- Rx3+

Notes : Refer to LVDS Transmitter Data Sheet for detail descriptions.

## Product Specification

### 3-3. Signal Timing Specifications

This is the signal timing required at the input of the LVDS Transmitter. All of the interface signal timing should be satisfied with the following specifications for it's proper operation.

**Table 5. Timing Table**

ITEM	Symbol		Min	Typ	Max	Unit	Note
DCLK	Period	tCLK	14.3	15.4	17.5	ns	
	Frequency	-	57	65	70	MHz	
Hsync	Period	tHP	1208	1344	1368		
	Width	tWH	8	136	-	tCLK	
Vsync	Period	tVP	774	806	830	tHP	*Note1)
	Frequency	fv	59	60	61	Hz	
	Width	tWW	2	6	-	tHP	
DE (Data Enable)	Horizontal Valid	tHV	1024	1024	1024	tCLK	tWH +tHBP + tHFP
	Horizontal Back Porch	tHBP	8	160			
	Horizontal Front Porch	tHFP	8	24			
	Horizontal Blank	-	24	320	tHP- tHV		
	Vertical Valid	tVV	768	768	768	tHP	tWV +tVBP + tVFP
	Vertical Back Porch	tVBP	2	29	-		
	Vertical Front Porch	tVFP	1	3	-		
	Vertical Blank	-	5	38	tVP- tVV		

**Note:** Hsync Period and Hsync Width-Active should be even number times of tCLK. If the value is odd number times of tCLK, display control signal can be asynchronous. This LCM operates in Hsync., Vsync. and Data Enable mode.

**Note1) :** The performance of the electro-optical characteristics are may be influenced by variance of the vertical refresh rates.

### 3-4. Signal Timing Waveforms

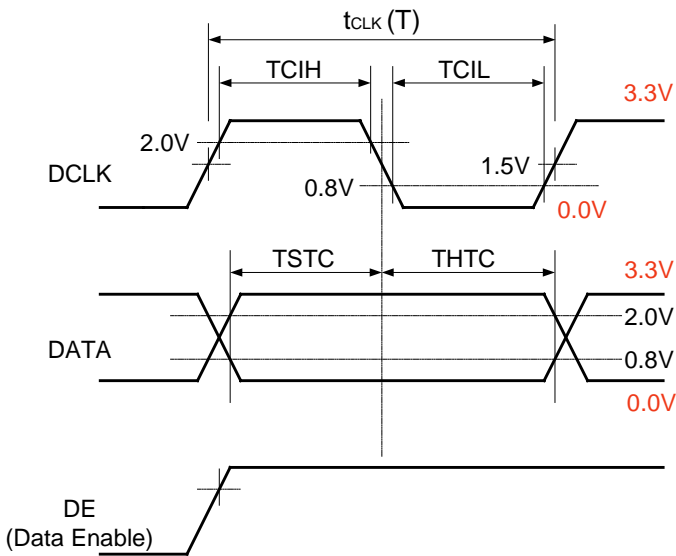
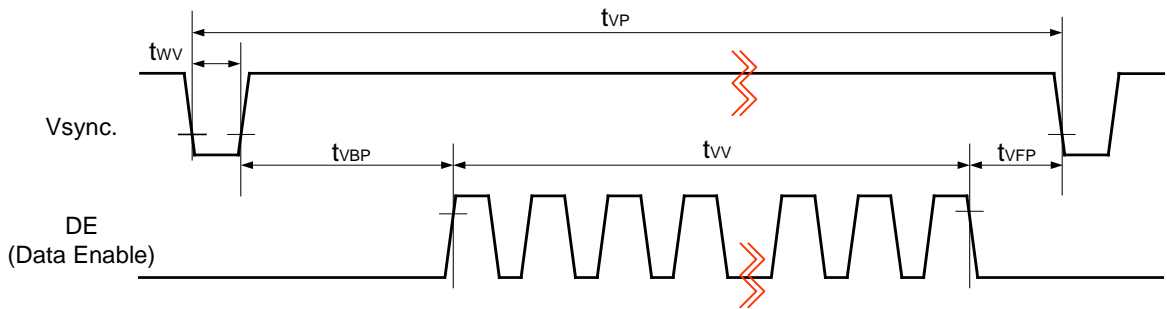
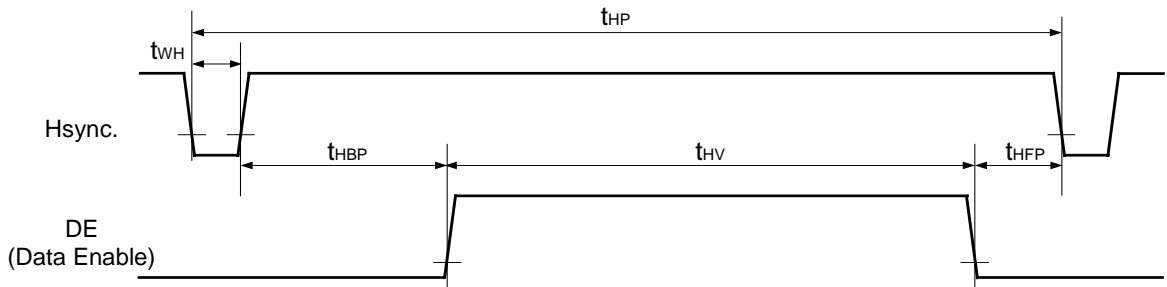

Symbol	Parameter	MIN	TYP	MAX	Unit
$T_{CIH}$	TxCLK IN High Time	0.35T	0.5T	0.65T	ns
$T_{CIL}$	TxCLK IN Low Time	0.35T	0.5T	0.65T	ns
$T_{STC}$	TxIN setup to TxCLK IN	2.5			ns
$T_{HTC}$	TxIN Hold to TxCLK IN	0			ns

Note : Refer to DS90C385 specification for more detail information

Product Specification

### 3-5. Color Data Reference

The table below provides a reference for color versus data output for displays based on 6 Bit FRC algorithm.

**Table 6. COLOR DATA REFERENCE**

Color		Input Color Data																							
		RED								GREEN								BLUE							
		MSB				LSB				MSB				LSB				MSB				LSB			
		R7	R6	R5	R4	R3	R2	R1	R0	G7	G6	G5	G4	G3	G2	G1	G0	B7	B6	B5	B4	B3	B2	B1	B0
Basic Color	Black	0	0	0	0	0	0	0	0	0	0	0	0	0	0	0	0	0	0	0	0	0	0	0	0
	Red	1	1	1	1	1	1	1	1	0	0	0	0	0	0	0	0	0	0	0	0	0	0	0	0
	Green	0	0	0	0	0	0	0	0	1	1	1	1	1	1	1	1	0	0	0	0	0	0	0	0
	Blue	0	0	0	0	0	0	0	0	0	0	0	0	0	0	0	0	1	1	1	1	1	1	1	1
	Cyan	0	0	0	0	0	0	0	0	1	1	1	1	1	1	1	1	1	1	1	1	1	1	1	1
	Magenta	1	1	1	1	1	1	1	1	0	0	0	0	0	0	0	0	1	1	1	1	1	1	1	1
	Yellow	1	1	1	1	1	1	1	1	1	1	1	1	1	1	1	1	0	0	0	0	0	0	0	0
	White	1	1	1	1	1	1	1	1	1	1	1	1	1	1	1	1	1	1	1	1	1	1	1	1
RED	RED (000)	0	0	0	0	0	0	0	0	0	0	0	0	0	0	0	0	0	0	0	0	0	0	0	0
	RED (001)	0	0	0	0	0	0	0	1	0	0	0	0	0	0	0	0	0	0	0	0	0	0	0	0
	...	.	.	.	.	.	.	.	.	.	.	.	.	.	.	.	.	.	.	.	.	.	.	.	.
	RED (252)	1	1	1	1	1	1	0	0	0	0	0	0	0	0	0	0	0	0	0	0	0	0	0	0
	RED (252)	1	1	1	1	1	1	0	1	0	0	0	0	0	0	0	0	0	0	0	0	0	0	0	0
	RED (252)	1	1	1	1	1	1	1	0	0	0	0	0	0	0	0	0	0	0	0	0	0	0	0	0
	RED (252)	1	1	1	1	1	1	1	1	0	0	0	0	0	0	0	0	0	0	0	0	0	0	0	0
GREEN	GREEN (000)	0	0	0	0	0	0	0	0	0	0	0	0	0	0	0	0	0	0	0	0	0	0	0	0
	GREEN (001)	0	0	0	0	0	0	0	0	0	0	0	0	0	0	0	1	0	0	0	0	0	0	0	0
	...	.	.	.	.	.	.	.	.	.	.	.	.	.	.	.	.	.	.	.	.	.	.	.	.
	GREEN (252)	0	0	0	0	0	0	0	0	1	1	1	1	1	1	0	0	0	0	0	0	0	0	0	0
	GREEN (252)	0	0	0	0	0	0	0	0	1	1	1	1	1	1	0	1	0	0	0	0	0	0	0	0
	GREEN (252)	0	0	0	0	0	0	0	0	1	1	1	1	1	1	1	0	0	0	0	0	0	0	0	0
	GREEN (252)	0	0	0	0	0	0	0	0	1	1	1	1	1	1	1	1	0	0	0	0	0	0	0	0
BLUE	BLUE (000)	0	0	0	0	0	0	0	0	0	0	0	0	0	0	0	0	0	0	0	0	0	0	0	0
	BLUE (001)	0	0	0	0	0	0	0	0	0	0	0	0	0	0	0	0	0	0	0	0	0	0	0	1
	...	.	.	.	.	.	.	.	.	.	.	.	.	.	.	.	.	.	.	.	.	.	.	.	.
	BLUE (252)	0	0	0	0	0	0	0	0	0	0	0	0	0	0	0	0	1	1	1	1	1	1	0	0
	BLUE (252)	0	0	0	0	0	0	0	0	0	0	0	0	0	0	0	0	1	1	1	1	1	1	0	1
	BLUE (252)	0	0	0	0	0	0	0	0	0	0	0	0	0	0	0	0	1	1	1	1	1	1	1	0
BLUE (252)	0	0	0	0	0	0	0	0	0	0	0	0	0	0	0	0	1	1	1	1	1	1	1	1	

**Note :** Users should be input true 8 Bit data streams via LVDS transmitter.

Product Specification

3-6. Power Sequence

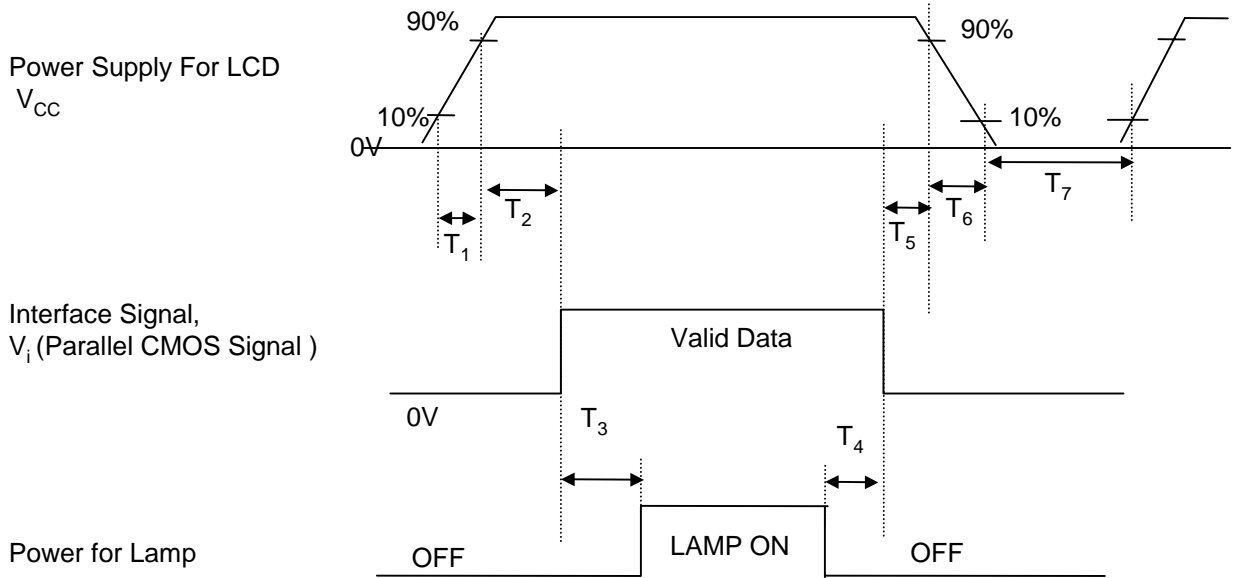

Parameter	Values			Units
	Min	Typ	Max	
T1	-	-	10	ms
T2	0.5	-	50	ms
T3	200	-	-	ms
T4	200	-	-	ms
T5	0.5	-	50	ms
T6	-	-	10	ms
T7	1	-	-	sec

- Notes :
1. Please avoid floating state of interface signal at invalid period.
  2. When the interface signal is invalid, be sure to pull down the power supply for LCD  $V_{CC}$  to 0V.
  3. Lamp power must be turn on after power supply for LCD an interface signal are valid.

Product Specification

### 4. Optical Specification

Optical characteristics are determined after the unit has been 'ON' and stable for approximately 30 minutes in a dark environment at 25 °C. The values specified are at an approximate distance 50cm from the LCD surface at a viewing angle of  $\Phi$  and  $\theta$  equal to 0 °.

FIG. 1 presents additional information concerning the measurement equipment and method.

**FIG. 1 Optical Characteristic Measurement Equipment and Method**

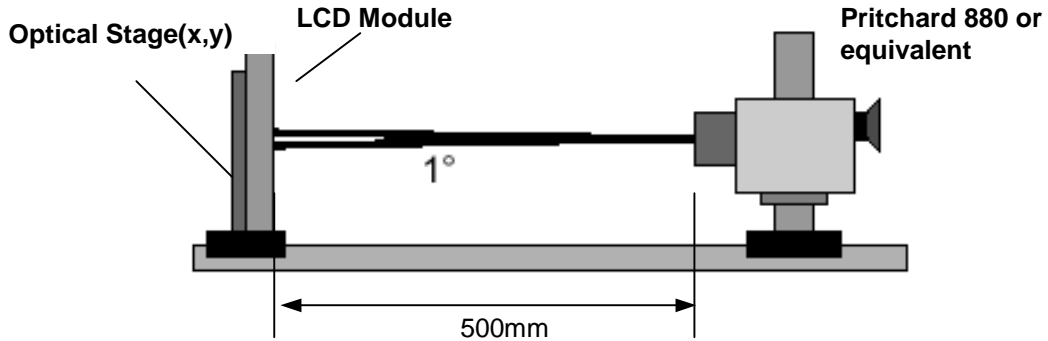

**Table 7. OPTICAL CHARACTERISTICS**

Ta=25 °C, V<sub>CC</sub>=5.0V, fv=60Hz  
Dclk=65MHz, I<sub>BL</sub>=8mA

Parameter	Symbol	Values			Units	Notes
		Min	Typ	MAx		
Contrast Ratio	CR	300	350			1
Surface Luminance, white	L <sub>WH</sub>	330	400		cd/m <sup>2</sup>	2
Luminance Variation	$\delta_{WHITE}$			1.3		3
Response Time	Tr		25	30	ms	4
Rise Time	Tr <sub>R</sub>		7	10		
Decay Time	Tr <sub>D</sub>		18	20		
Color Coordinates						
RED	RX	0.602	0.632	0.662		
RY		0.309	0.339	0.369		
GREEN	GX	0.251	0.281	0.311		
GY		0.567	0.597	0.627		
BLUE	BX	0.113	0.143	0.173		
BY		0.052	0.082	0.112		
WHITE	WX	0.254	0.284	0.314		
WY		0.265	0.295	0.325		
Viewing Angle						
x axis, right( $\phi=0^\circ$ )	$\theta_r$	70	75		degree	5
x axis, left ( $\phi=180^\circ$ )	$\theta_l$	70	75			
y axis, up ( $\phi=90^\circ$ )	$\theta_u$	45	50			
y axis, down ( $\phi=270^\circ$ )	$\theta_d$	65	70			
Gray Scale						6

Product Specification

Notes 1. Contrast Ratio(CR) is defined mathematically as :

$$\text{Contrast Ratio} = \frac{\text{Surface Luminance with all white pixels}}{\text{Surface Luminance with all black pixels}}$$

2. Surface luminance is luminance value at point 1 across the LCD surface 50cm from the surface with all pixels displaying white. For more information see FIG 2. When  $I_{BL}=8mA$ ,  $L_{WH}=330cd/m^2(\text{Min.})$   $400cd/m^2(\text{Typ.})$

$$L_{WH} = L_{on1}$$

Where  $L_{on1}$  is the luminance with all pixels displaying white at center 1 location.

3. The variation in surface luminance ,  $\delta$  WHITE is defined as :

$$\delta \text{ WHITE} = \frac{\text{Maximum}(L_{on1}, L_{on2}, L_{on4}, L_{on7}, L_{on9})}{\text{Minimum}(L_{on1}, L_{on2}, L_{on3}, L_{on47}, L_{on9})}$$

Where  $L_{on1}$  to  $L_{on5}$  are the luminance with all pixels displaying white at 5 locations

4. Response time is the time required for the display to transition from to black(Rise Time,  $Tr_R$ ) and from black to white(Decay Time,  $Tr_D$ ). For additional information see FIG 3.

5. Viewing angle is the angle at which the contrast ratio is greater than 5. The angles are determined for the horizontal or x axis and the vertical or y axis with respect to the z axis which is normal to the LCD surface. For more information see FIG 4.

6. Gray scale specification

Gray Level	Luminance [%] (Typ)
L0	0.22
L15	0.36
L31	0.85
L47	2.13
L63	4.30
L79	7.43
L95	11.4
L111	16.4
L127	22.1
L143	28.7
L159	36.5
L175	45.2
L191	55.9
L207	66.9
L223	79.0
L239	91.2
L255	100

Product Specification

**FIG. 2 Luminance**

<measuring point for surface luminance & measuring point for luminance variation>

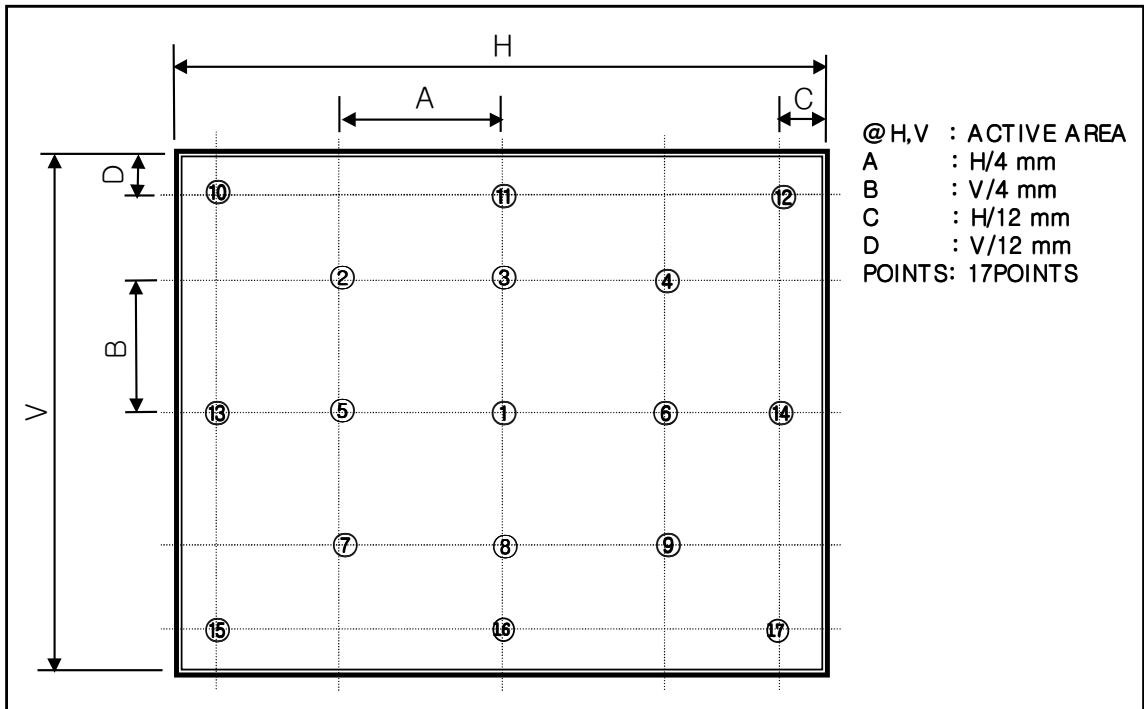

**FIG. 3 Response Time**

The response time is defined as the following figure and shall be measured by switching the input signal for "black" and "white".

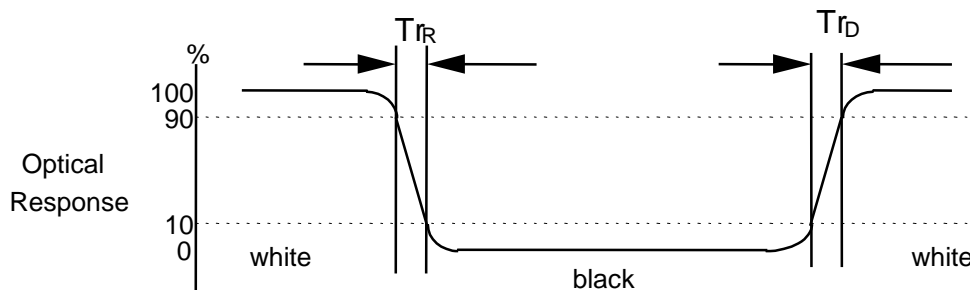

Product Specification

FIG. 4 Viewing angle

<Dimension of viewing angle range>

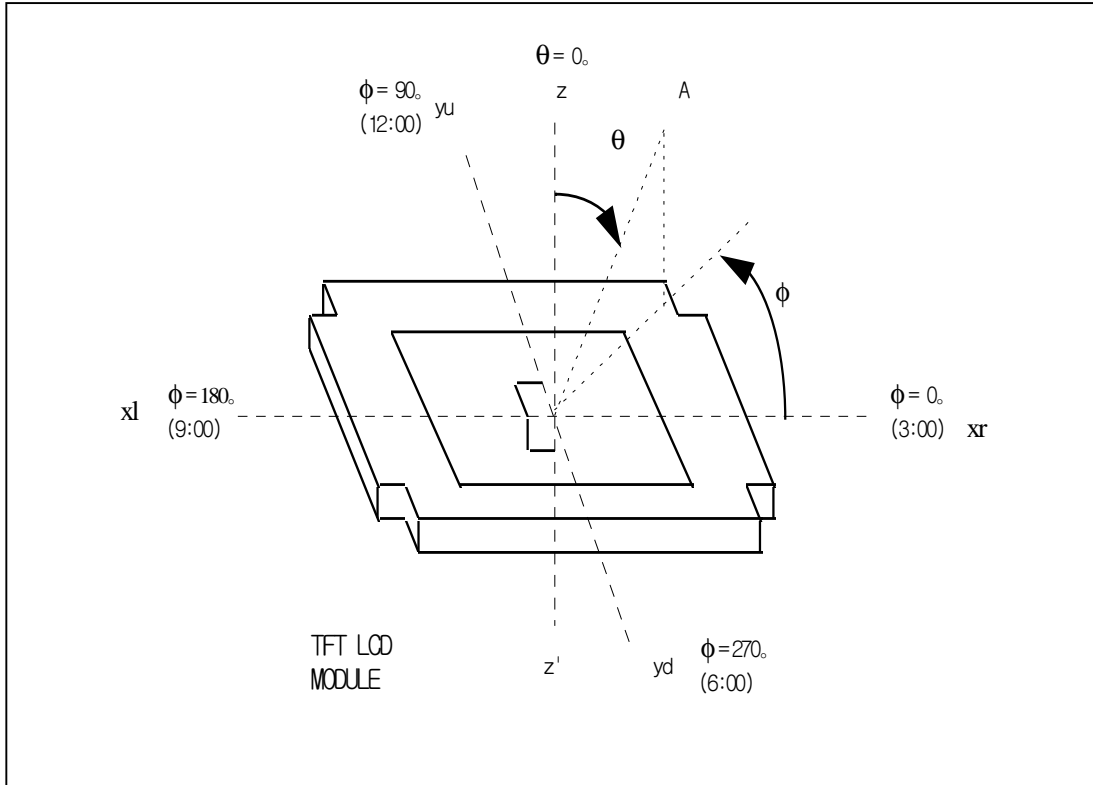

Product Specification

### 5. Mechanical Characteristics

The contents provide general mechanical characteristics for the model LC151X01-C3. In addition the figures in the next page are detailed mechanical drawing of the LCD.

Outline Dimension	Horizontal	352 ± 0.5mm
	Vertical	263.5 ± 0.5mm
	Depth	18.0 ± 0.5mm
Bezel Area	Horizontal	311.2 ± 0.5mm
	Vertical	234.4 ± 0.5mm
Active Display Area	Horizontal	307.2mm
	Vertical	230.4mm
Weight	1750g (Typ.)	1850g (Max.)
Surface Treatment	Hard coating(3H) Anti-glare treatment of the front polarizer	

Product Specification

<FRONT VIEW>

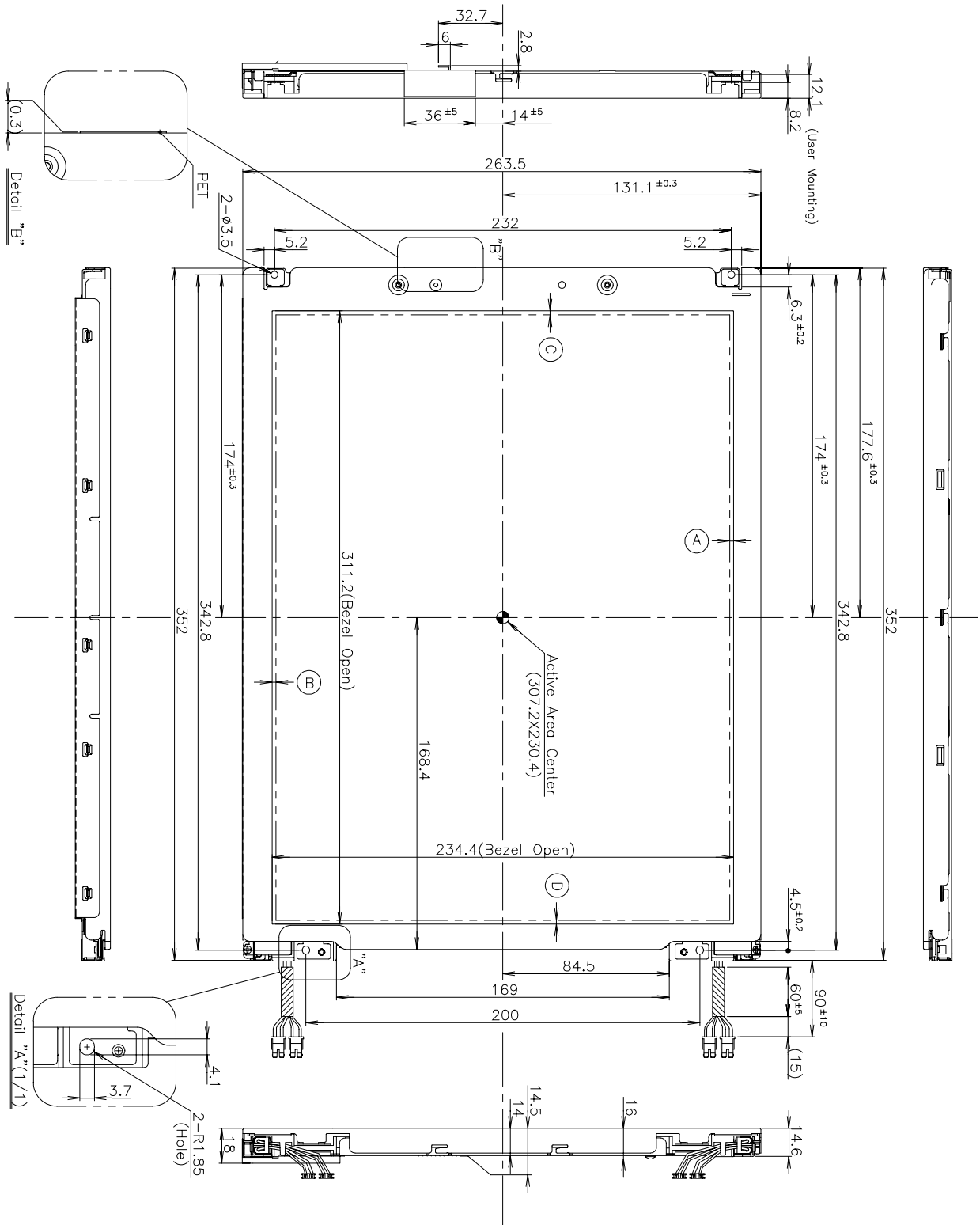

Product Specification

<REAR VIEW>

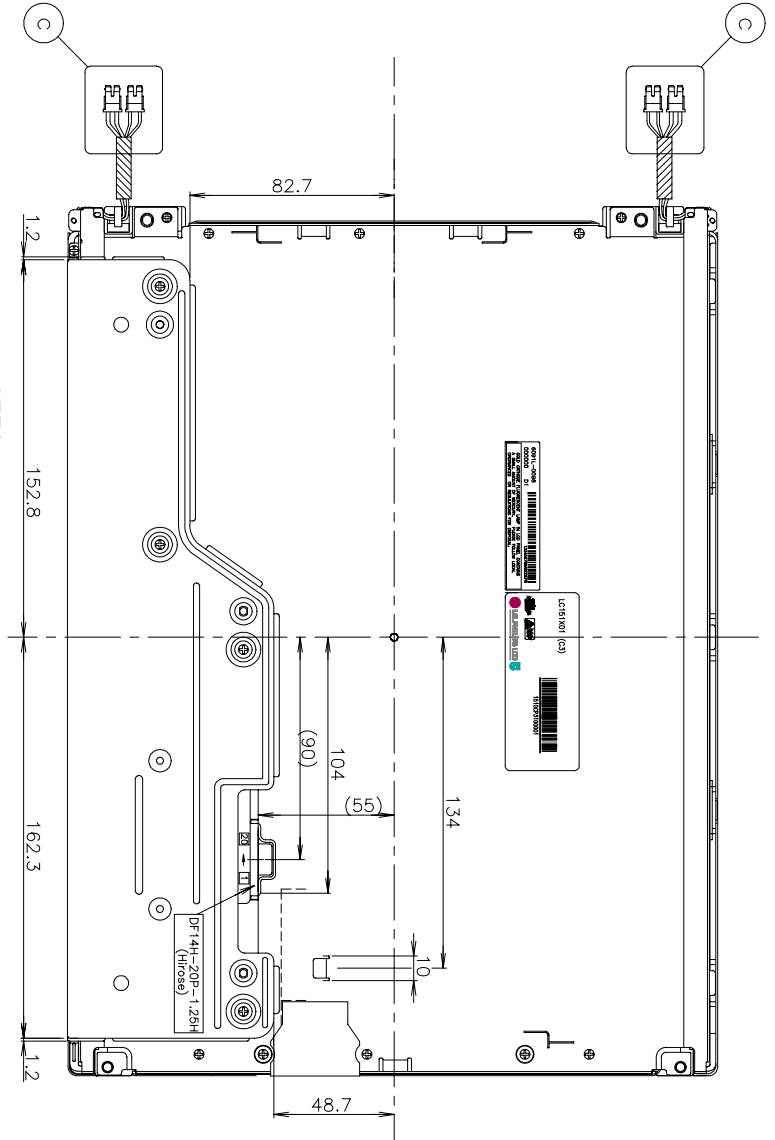

NOTES

1. Unspecified tolerances to be  $\pm 0.5$
2. This drawing is only preliminary data and can be changed without previous notice
3. Gap between Top case and Glass is  $0.2(+0.5/-0.2)$
4. Tilt and partial disposition tolerance of display area are as follow
  - 1) Y-Direction :  $LA-BI \leq 1.0$
  - 2) X-Direction :  $IC-DI \leq 1.0$

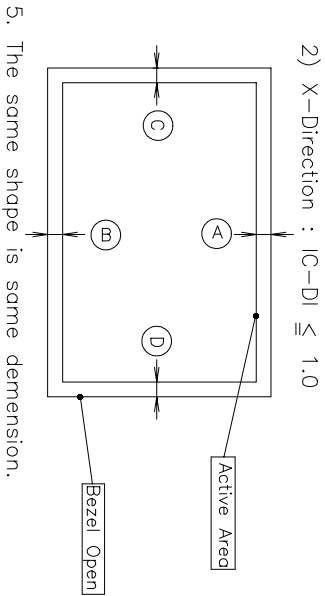
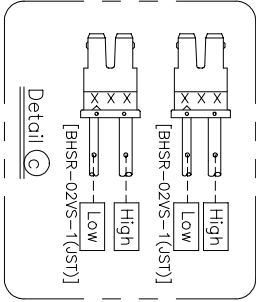

Product Specification

## 6. Reliability

### Environment test condition

No	Test Item	Condition
1	High temperature storage test	Ta= 60°C 240h
2	Low temperature storage test	Ta= -20°C 240h
3	High temperature operation test	Ta= 50°C 50%RH 240h
4	Low temperature operation test	Ta= 0°C 240h
5	Vibration test (non-operating)	Wave form : random Vibration level : 1.0G RMS Bandwidth : 10-500Hz Duration : X,Y,Z, 20 min One time each direction
6	Shock test (non-operating)	Shock level : 120G Waveform : half sine wave, 2ms Direction : ± X, ± Y, ± Z One time each direction
	Altitude operating storage / shipment	0 - 10,000 feet(3048m) 0 - 40,000 feet(12,192m)

#### { Result Evaluation Criteria }

There should be no change which might affect the practical display function when the display quality test is conducted under normal operating condition.

## 7. International Standards

### 7-1. Safety

- a) UL 1950 Third Edition, Underwriters Laboratories, Inc. Jan. 28, 1995.  
Standard for Safety of Information Technology Equipment Including Electrical Business Equipment.
- b) CAN/CSA C22.2 No. 950-95 Third Edition, Canadian Standards Association, Jan. 28, 1995.  
Standard for Safety of Information Technology Equipment Including Electrical Business Equipment.
- c) EN 60950 : 1992+A1: 1993+A2: 1993+A3: 1995+A4: 1997+A11: 1997  
IEC 950 : 1991+A1: 1992+A2: 1993+A3: 1995+A4: 1996  
European Committee for Electrotechnical Standardization(CENELEC)  
EUROPEAN STANDARD for Safety of Information Technology Equipment Including Electrical Business Equipment.

### 7-2. EMC

- a) ANSI C63.4 "Methods of Measurement of Radio-Noise Emissions from Low-Voltage Electrical and Electrical Equipment in the Range of 9kHz to 40GHz. "American National Standards Institute(ANSI), 1992
- b) C.I.S.P.R "Limits and Methods of Measurement of Radio Interface Characteristics of Information Technology Equipment." International Special Committee on Radio Interference.
- c) EN 55022 "Limits and Methods of Measurement of Radio Interface Characteristics of Information Technology Equipment." European Committee for Electrotechnical Standardization.(CENELEC), 1998

Product Specification

## 8. Packing

### 8-1. Designation of Lot Mark

a) Lot Mark

A	B	C	D	E	F	G	H	I	J	K	L	M
---	---	---	---	---	---	---	---	---	---	---	---	---

A,B,C : SIZE

D : YEAR

E : MONTH

F,G : PANEL CODE

H : ASSEMBLY CODE

I,J,K,L,M : SERIAL NO.

Note

1. YEAR

Year	97	98	99	2000	2001	2002	2003	2004	2005	2006	2007
Mark	7	8	9	0	1	2	3	4	5	6	7

2. MONTH

Month	Jan	Feb	Mar	Apr	May	Jun	Jul	Aug	Sep	Oct	Nov	Dec
Mark	1	2	4	4	5	6	7	8	9	A	B	C

3. Serial No.

Year	1 ~ 99999	100000 ~
Mark	00001 ~ 99999	A0001 ~ A9999, ..... , Z9999

b) Location of Lot Mark

Serial NO. is printed on the label. The label is attached to the backside of the LCD module.  
This is subject to change without prior notice.

### 8-2. Packing Form

a) Package quantity in one box : 8 pcs

b) Box Size : 587mm × 408mm × 378mm

## 9. PRECAUTIONS

Please pay attention to the followings when you use this TFT LCD module.

### 9-1. MOUNTING PRECAUTIONS

- (1) You must mount a module using holes arranged in four corners or four sides.
- (2) You should consider the mounting structure so that uneven force (ex. Twisted stress) is not applied to the module. And the case on which a module is mounted should have sufficient strength so that external force is not transmitted directly to the module.
- (3) Please attach the surface transparent protective plate to the surface in order to protect the polarizer. Transparent protective plate should have sufficient strength in order to resist external force.
- (4) You should adopt radiation structure to satisfy the temperature specification.
- (5) Acetic acid type and chlorine type materials for the cover case are not desirable because the former generates corrosive gas of attacking the polarizer at high temperature and the latter causes circuit break by electro-chemical reaction.
- (6) Do not touch, push or rub the exposed polarizers with glass, tweezers or anything harder than HB pencil lead. And please do not rub with dust clothes with chemical treatment. Do not touch the surface of polarizer for bare hand or greasy cloth. (Some cosmetics are detrimental to the polarizer.)
- (7) When the surface becomes dusty, please wipe gently with absorbent cotton or other soft materials like chamois soaks with petroleum benzene. Normal-hexane is recommended for cleaning the adhesives used to attach front / rear polarizers. Do not use acetone, toluene and alcohol because they cause chemical damage to the polarizer.
- (8) Wipe off saliva or water drops as soon as possible. Their long time contact with polarizer causes deformations and color fading.
- (9) Do not open the case because inside circuits do not have sufficient strength.

### 9-2. OPERATING PRECAUTIONS

- (1) The spike noise causes the mis-operation of circuits. It should be lower than following voltage :  
 $V = \pm 200\text{mV}$  (Over and under shoot voltage)
- (2) Response time depends on the temperature. (In lower temperature, it becomes longer.)
- (3) Brightness depends on the temperature. (In lower temperature, it becomes lower.)  
And in lower temperature, response time (required time that brightness is stable after turned on) becomes longer.
- (4) Be careful for condensation at sudden temperature change. Condensation makes damage to polarizer or electrical contacted parts. And after fading condensation, smear or spot will occur.
- (5) When fixed patterns are displayed for a long time, remnant image is likely to occur.
- (6) Module has high frequency circuits. Sufficient suppression to the electromagnetic interference shall be done by system manufacturers. Grounding and shielding methods may be important to minimize the interference.

### 9-3. ELECTROSTATIC DISCHARGE CONTROL

Since a module is composed of electronic circuits, it is not strong to electrostatic discharge. Make certain that treatment persons are connected to ground through wrist band etc. And don't touch interface pin directly.

### 9-4. PRECAUTIONS FOR STRONG LIGHT EXPOSURE

Strong light exposure causes degradation of polarizer and color filter.

### 9-5. STORAGE

When storing modules as spares for a long time, the following precautions are necessary.

- (1) Store them in a dark place. Do not expose the module to sunlight or fluorescent light. Keep the temperature between 5°C and 35°C at normal humidity.
- (2) The polarizer surface should not come in contact with any other object.  
It is recommended that they be stored in the container in which they were shipped.

### 9-6. HANDLING PRECAUTIONS FOR PROTECTION FILM

- (1) The protection film is attached to the bezel with a small masking tape.  
When the protection film is peeled off, static electricity is generated between the film and polarizer. This should be peeled off slowly and carefully by people who are electrically grounded and with well ion-blown equipment or in such a condition, etc.
- (2) When the module with protection film attached is stored for a long time, sometimes there remains a very small amount of glue still on the bezel after the protection film is peeled off.
- (3) You can remove the glue easily. When the glue remains on the bezel surface or its vestige is recognized, please wipe them off with absorbent cotton waste or other soft material like chamois soaked with normal-hexane.