

Product Specification

SPECIFICATION FOR APPROVAL

- (●) Preliminary Specification
 () Final Specification

Title	23.0" WXGA TFT LCD
-------	--------------------

BUYER	Philips CE
MODEL	

SUPPLIER	LG.Philips LCD Co., Ltd.
*MODEL	LC230W01
MODEL	A2

*When you obtain standard approval,
 please use the above model name without suffix

SIGNATURE	DATE
/	
/	
/	

Please return 1 copy for your confirmation with your signature and comments.

SIGNATURE	DATE
S.W.Lee / G.Manager	
REVIEWED BY	
S.G.Hong/ Manager	
PREPARED BY	
P.Y.Kim / Engineer	

**MNT/TV Products Engineering Dept.
 LG. Philips LCD Co., Ltd**

Product Specification

Contents

No	ITEM	Page
	COVER	1
	CONTENTS	2
	RECORD OF REVISIONS	3
1	GENERAL DESCRIPTION	4
2	ABSOLUTE MAXIMUM RATINGS	5
3	ELECTRICAL SPECIFICATIONS	6
3-1	ELECTRICAL CHARACTERISTICS	6
3-2	INTERFACE CONNECTIONS	7
3-3	SIGNAL TIMING SPECIFICATIONS	11
3-4	SIGNAL TIMING WAVEFORMS	12
3-5	COLOR INPUT DATA REFERENCE	13
3-6	POWER SEQUENCE	14
3-7	LUMINANCE CONTROLS	15
4	OPTICAL SPECIFICATIONS	17
5	MECHANICAL CHARACTERISTICS	21
6	RELIABILITY	24
7	INTERNATIONAL STANDARDS	25
7-1	SAFETY	
7-2	EMC	
8	PACKING	26
8-1	DESIGNATION OF LOT MARK	
8-2	PACKING FORM	
9	PRECAUTIONS	27

Product Specification

1. General Description

The LC230W01 is a Color Active Matrix Liquid Crystal Display with an integral Cold Cathode Fluorescent Lamp(CCFL) backlight system. The matrix employs a-Si Thin Film Transistor as the active element. It is a transmissive type display operating in the normally black mode. This TFT-LCD has a 23.0 inch diagonally measured active display area with XGA resolution (768 vertical by 1280 horizontal pixel array). Each pixel is divided into Red, Green and Blue sub-pixels or dots which are arranged in vertical stripes. Gray scale or the brightness of the sub-pixel color is determined with a 8-bit gray scale signal for each dot, thus, presenting a palette of more than 16,7M(true) colors with 8Bit.

The LC230W01 has been designed to apply the 8Bit LVDS interface.

It is intended to support LCD TV, PCTV where high brightness, wide viewing angle, high color saturation, and high color are important.

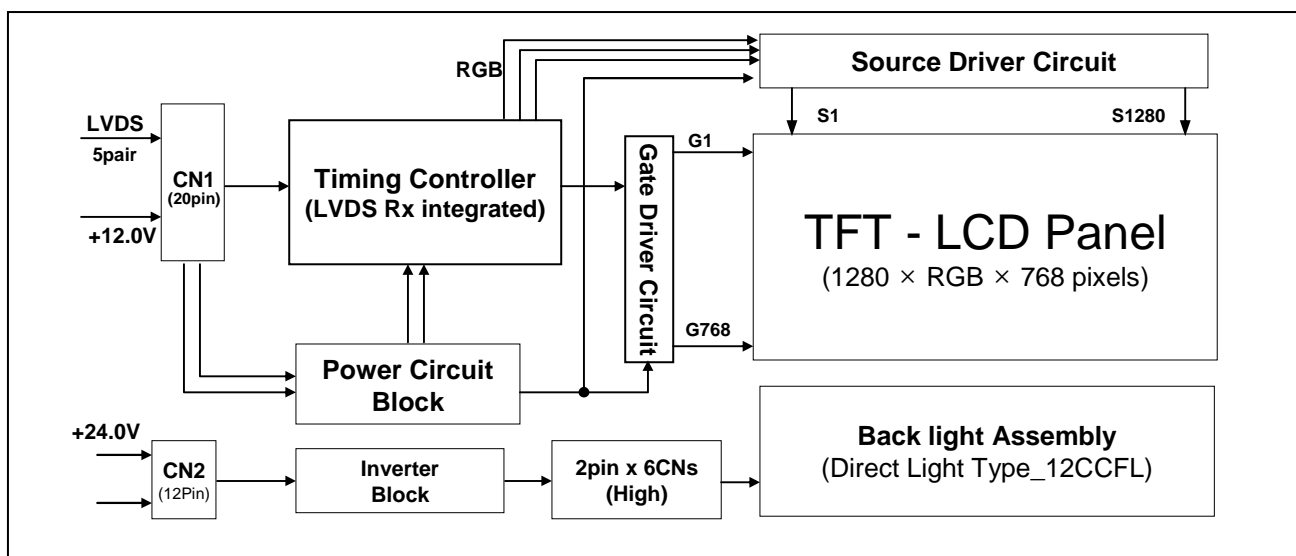

General Features

Active Screen Size	23.01 inches(584.40mm) diagonal
Outline Dimension	528.0(H) x 326.0(V) x 34.5(D) mm(Typ.)
Pixel Pitch	0.1305mm x 0.3915 x RGB
Pixel Format	1280 horiz. By 768 vert. Pixels RGB strip arrangement
Color Depth	16.7M colors
Luminance, White	450 cd/m ² (Center 1 points typ.)
Viewing Angle(CR>10)	View Angle Free
Power Consumption	Total 68.9Watt (Typ.)
Weight	3,000g (Typ.)
Display Operating Mode	Transmissive mode, Normally Black
Surface Treatment	Hard coating(3H), Anti-glare treatment of the front polarizer,

2. Absolute Maximum Ratings

The following are maximum values which, if exceeded, may cause faulty operation or damage to the unit.

Table 1. ABSOLUTE MAXIMUM RATINGS

Parameter	Symbol	Values		Units	Notes
		Min	Max		
Power Input Voltage	V_{LCD}	-0.3	+14.0	Vdc	at $25 \pm 5^{\circ}C$
Operating Temperature	T_{OP}	0	+50	$^{\circ}C$	1
Storage Temperature	HST	-20	+60	$^{\circ}C$	
Operating Ambient Humidity	H_{OP}	10	90	%RH	
Storage Humidity	HST	10	90	%RH	

Notes : 1. Temperature and relative humidity range are shown in the figure below.
Wet bulb temperature should be $39^{\circ}C$ Max, and no condensation of water.

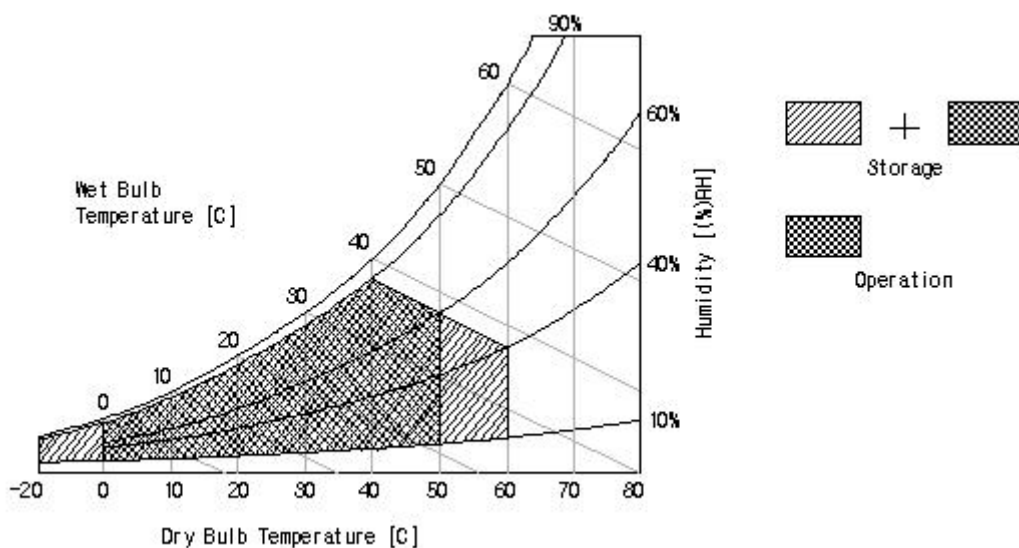

Product Specification

3. Electrical Specifications

3-1. Electrical Characteristics

The LC230W01 requires two power inputs. One is employed to power the LCD electronics and to drive the TFT array and liquid crystal. The second input power for the CCFL/Backlight, is to power the inverter.

Table 2_1. LCD PANEL ELECTRICAL CHARACTERISTICS

Parameter	Symbol	Values			Unit	Notes
		Min	Typ	Max		
Module :						
Power Supply Input Voltage	V_{LCD}	11.4	12.0	12.6	Vdc	
Power Supply Input Current	I_{LCD}		240	280	mA	1
Power Consumption	P_{LCD}		2.9		Watt	
Rush current	I_{RUSH}	-	-	2.0	A	2

- Notes: 1. The specified current and power consumption are under the $V_{LCD}=12.0V$, $25^{\circ}C$, $f_v=60Hz$ condition whereas mosaic pattern(8 x 6) is displayed and f_v is the frame frequency.
 2. The duration of rush current is about 2ms and rising time of Power Input is 1ms(min).

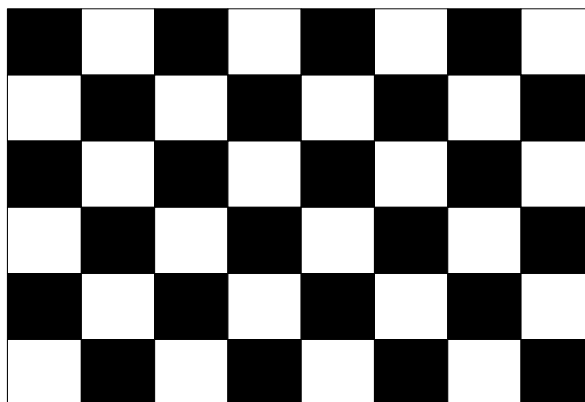

Mosaic Pattern(8X6)

Product Specification

Table 2_2. INVERTER ELECTRICAL CHARACTERISTICS

Parameter		Symbol	Values			Unit	Notes
			Min	Typ	Max		
Inverter :							
Power Supply Input Voltage		V_{DDB}	22.8	24.0	25.2	Vdc	
Power Supply Input Current		I_{DDB}		2750		mA	
Power Consumption		P_B		66		W	
Input Voltage for Control System Signals	BRTI Signal		VBI	0		3.3	V
	BRTP Signal	Low	VBPL	0		0.8	V
		High	VBPH	2.0		5.0	V
	BRTC Signal	Low	VBCL	0		0.8	V
		High	VCBH	2.0		5.0	V
	PWSEL Signal	Low	VBSL	0		0.8	V
High		VBSH	2.0		5.0	V	
Lamp :							
Life Time			50,000			Hrs	1

Notes : 1. The life is determined as the time at which luminance of the lamp is 50% compared to that of initial value at the typical lamp current on condition of continuous operating at $25 \pm 2^\circ\text{C}$.

Product Specification

3-2. Interface Connections

This LCD employs Two interface connections, a 20 pin connector is used for the module electronics and a 12Pin Connector is used for the integral backlight system.

3-2-1. LCD Module

- LCD Connector : DF14H-20P-1.25H(Manufactured by Hirose) or Equivalent
- Mating connector : DF14-20S-1.25C(Manufactured by Hirose) or Equivalent

Table 3. MODULE CONNECTOR PIN CONFIGURATION

Pin No	Symbol	Description	Output Pin # (LVDS Tx)
1	V _{LCD}	Power Supply +12.0V	
2	V _{LCD}	Power Supply +12.0V	
3	GND	Power Ground.	
4	GND	Power Ground	
5	RXIN0-	LVDS Receiver Signal(-)	PIN#48
6	RXIN0+	LVDS Receiver Signal(+)	PIN#47
7	GND	Ground	
8	RXIN1-	LVDS Receiver Signal(-)	PIN#46
9	RXIN1+	LVDS Receiver Signal(+)	PIN#45
10	GND	Ground	
11	RXIN2-	LVDS Receiver Signal(-)	PIN#42
12	RXIN2+	LVDS Receiver Signal(+)	PIN#41
13	GND	Ground	
14	RXCLK IN-	LVDS Receiver Clock Signal(-)	PIN#40
15	RXCLK IN+	LVDS Receiver Clock Signal(+)	PIN#39
16	GND	Ground	
17	RXIN3-	LVDS Receiver Signal(-)	PIN#38
18	RXIN3+	LVDS Receiver Signal(+)	PIN#37
19	GND	Ground	
20	GND	Ground	

- Notes: 1. All GND(ground) pins should be connected together and to Vss which should also be connected to the LCD's metal frame.
2. All V_{LCD} (power input) pins should be connected together.

Rear view of LCM

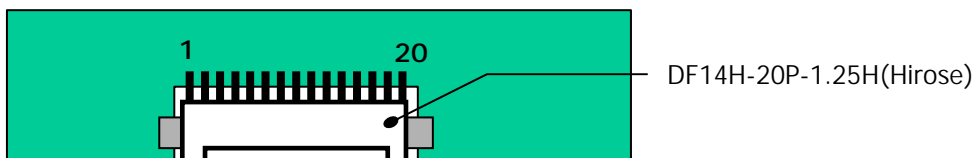

Product Specification

Table 4. REQUIRED SIGNAL ASSIGNMENT FOR FLATLINK'S Transmitter(THC63LVDM83A/LVDF83A)

Pin #	Pin Name	Symbol	Description	Output
51	TxIN0	Red0 [LSB]	Red Pixel Data	Rx0- Rx0+
52	TxIN1	Red1	Red Pixel Data	
54	TxIN2	Red2	Red Pixel Data	
55	TxIN3	Red3	Red Pixel Data	
56	TxIN4	Red4	Red Pixel Data	
2	TxIN5	Red7 [MSB]	Red Pixel Data	Rx3- Rx3+
3	TxIN6	Red5	Red Pixel Data	Rx0- Rx0+
4	TxIN7	Green0 [LSB]	Green Pixel Data	
6	TxIN8	Green1	Green Pixel Data	Rx1- Rx1+
7	TxIN9	Green2	Green Pixel Data	Rx3- Rx3+
8	TxIN10	Green6	Green Pixel Data	
10	TxIN11	Green7 [MSB]	Green Pixel Data	
11	TxIN12	Green3	Green Pixel Data	Rx1- Rx1+
12	TxIN13	Green4	Green Pixel Data	
14	TxIN14	Green5	Green Pixel Data	
15	TxIN15	Blue0 [LSB]	Blue Pixel Data	
16	TxIN16	Blue6	Blue Pixel Data	Rx3- Rx3+
18	TxIN17	Blue7 [MSB]	Blue Pixel Data	
19	TxIN18	Blue1	Blue Pixel Data	Rx1- Rx1+
20	TxIN19	Blue2	Blue Pixel Data	Rx2- Rx2+
22	TxIN20	Blue3	Blue Pixel Data	
23	TxIN21	Blue4	Blue Pixel Data	
24	TxIN22	Blue5	Blue Pixel Data	
25	TxIN23	RES		Rx3- Rx3+
27	TxIN24	Hsync.	No connection, If unnecessary	Rx2- Rx2+
28	TxIN25	Vsync.	No connection, If unnecessary	
30	TxIN26	EN	Data Enable	
50	TxIN27	Red6	Red Pixel Data	Rx3- Rx3+

Notes: 1. Refer to LVDS Transmitter Data Sheet for detail descriptions.
 2. 7 means MSB and 0 means LSB at R,G,B pixel data.

Product Specification

Table 5. REQUIRED SIGNAL ASSIGNMENT FOR LVDS Transmitter (THC63LVDM83A / LVDF83A)

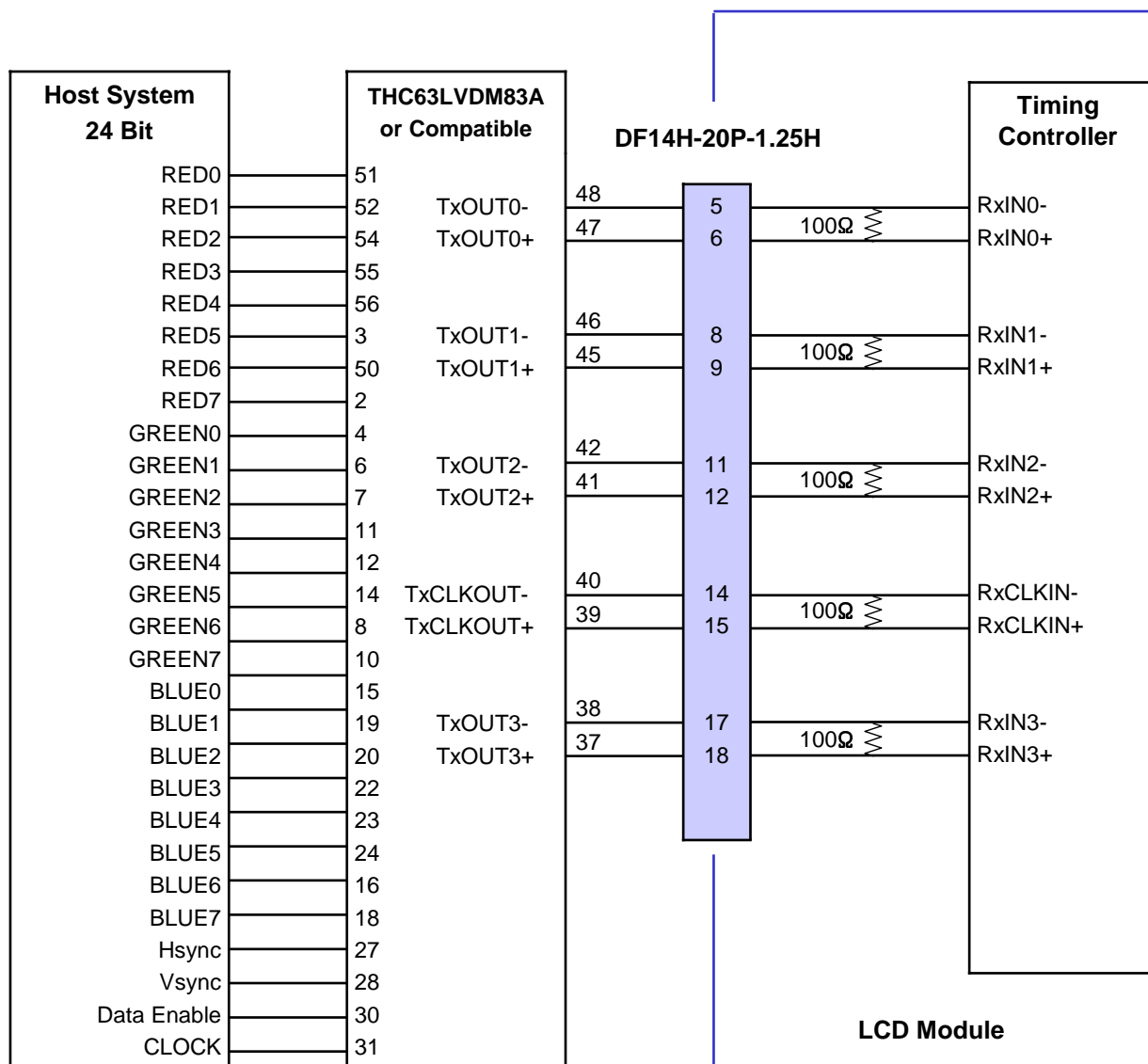

Notes : The LCD Module uses a 100Ohm resistor between positive and negative lines of each receiver input. Recommended Transmitter : See the data sheet for THC63LVDM83A(Thine Electronics)

Product Specification

3-2-2. Backlight Inverter

- Inverter Connector : DF3D-12P-2H(Manufactured by Hirose) or Equivalent
- Mating Connector : DF3-12S-2C(Manufactured by Hirose) or Equivalent

Table 6. INVERTER CONNECTOR PIN CONFIGULATION

Pin No	Symbol	Description	Remarks
12	GND	Backlight Ground	Note 1
11	GND	Backlight Ground	
10	GND	Backlight Ground	
9	NC	Not Connection	
8	BRTC	Backlight ON/OFF Signal	On : High or Open, Off : Low
7	BRTI	Luminance Control by voltage method	Note 2
6	BRTP	PWM Signal	
5	PWSEL	Select of luminance control signal method	
4	NC	Not Connection	
3	Vddb	Power Supply +24.0V	
2	Vddb	Power Supply +24.0V	
1	Vddb	Power Supply +24.0V	

- Notes : 1. GND is connected to Metal Frame.
2. See "3-7 Luminance controls"

Rear view of LCM

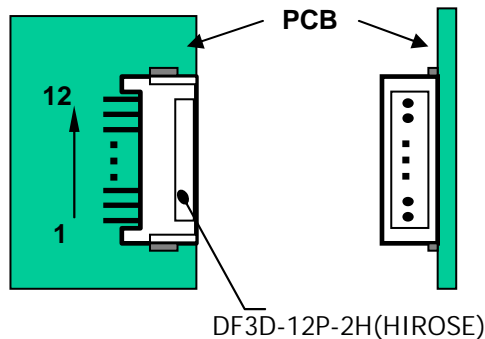

Product Specification

3-3. Signal Timing Specifications

This is the signal timing required at the input of the LVDS Transmitter. All of the interface signal timing should be satisfied with the following specifications for it's proper operation.

Table 7. TIMING TABLE

ITEM	Symbol	Min	Typ	Max	Unit	Note
DCLK	Period	tCLK	12.2	12.5	-	ns
	Frequency	-	-	80	82	MHz
Hsync	Period	tHP	1312	1648	-	tCLK
	Frequency	fH	44.0	48.54	52.0	kHz
	Width	tWH	8	16	-	tCLK
Vsync	Period	tVP	774	810	-	tHP
	Frequency	fV	47	60	63	Hz
	Width	tWV	2	6	-	tHP
DE (Data Enable)	Horizontal Valid	tHV	1280	1280	1280	tCLK
	Horizontal Back Porch	tHBP	8	80	-	
	Horizontal Front Porch	tHFP	16	272	-	
	Horizontal Blank	-	32	368	-	
	Vertical Valid	tVV	768	768	768	tHP
	Vertical Back Porch	tVBP	2	20	-	
	Vertical Front Porch	tVFP	2	16	-	
	Vertical Blank	-	6	42	-	

Notes : Hsync period and Hsync width-active should be even number times of tCLK. If the value is odd number times of tCLK, display control signal can be asynchronous. In order to operate this LCM a Hsync., Vsync and DE(data enable) signals should be used.

1. The performance of the electro-optical characteristics are may be influenced by variance of the vertical refresh rates.
2. Vsync, Hsync should be keep the above specification.
3. Hsync Period should be a double number of character (8).

Product Specification

3-4. Signal Timing Waveforms

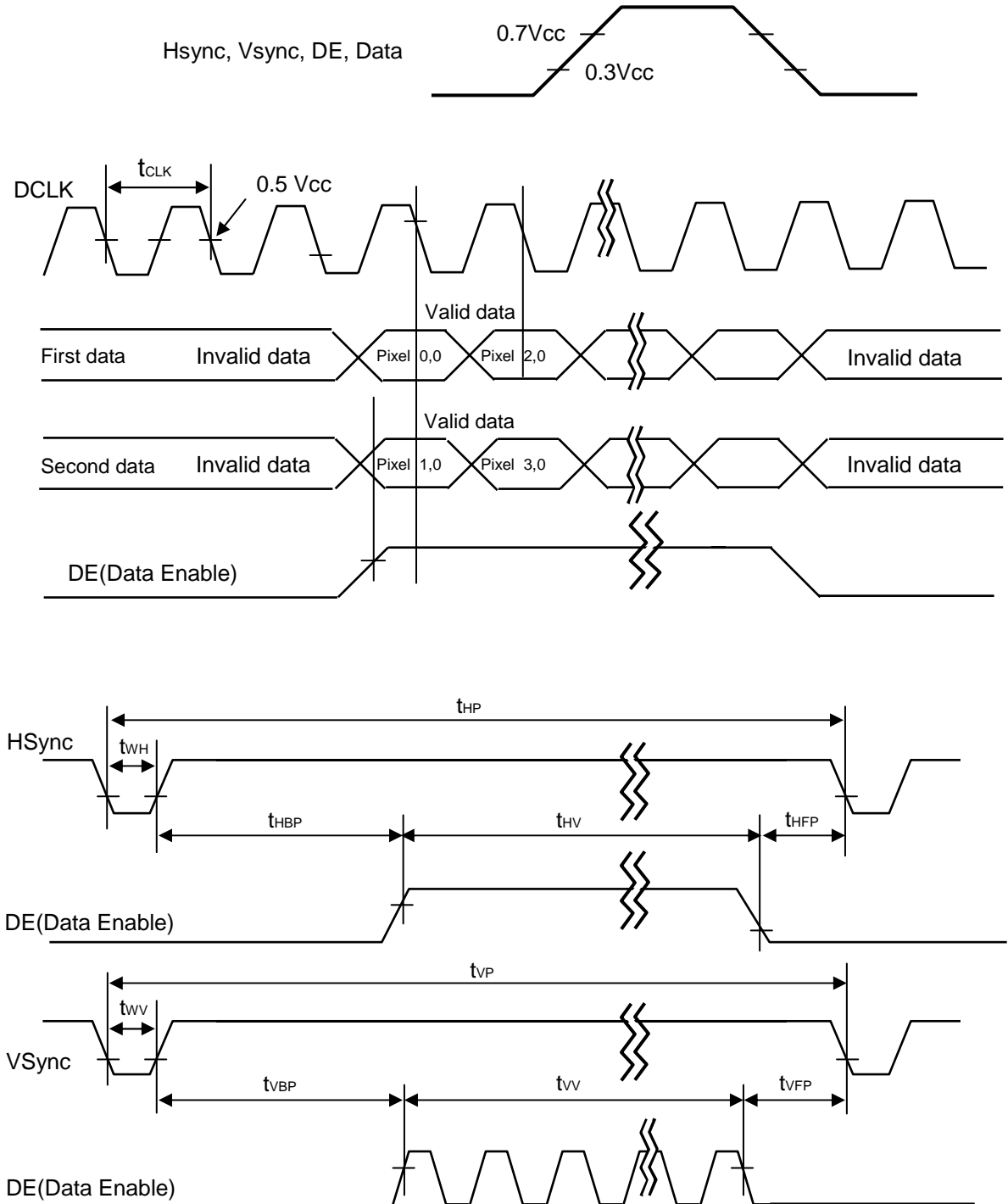

Product Specification

3-5. Color Input Data Reference

The Brightness of each primary color(red,green,blue) is based on the 8-bit gray scale data input for the color; the higher the binary input, the brighter the color. The table below provides a reference for color versus data input.

Table 8. COLOR DATA REFERENCE

Color		Input Color Data																							
		RED								GREEN								BLUE							
		MSB				LSB				MSB				LSB				MSB				LSB			
		R7	R6	R5	R4	R3	R2	R1	R0	G7	G6	G5	G4	G3	G2	G1	G0	B7	B6	B5	B4	B3	B2	B1	B0
Basic Color	Black	0	0	0	0	0	0	0	0	0	0	0	0	0	0	0	0	0	0	0	0	0	0	0	0
	Red (255)	1	1	1	1	1	1	1	1	0	0	0	0	0	0	0	0	0	0	0	0	0	0	0	0
	Green (255)	0	0	0	0	0	0	0	0	1	1	1	1	1	1	1	1	0	0	0	0	0	0	0	0
	Blue (255)	0	0	0	0	0	0	0	0	0	0	0	0	0	0	0	0	1	1	1	1	1	1	1	1
	Cyan	0	0	0	0	0	0	0	0	1	1	1	1	1	1	1	1	1	1	1	1	1	1	1	1
	Magenta	1	1	1	1	1	1	1	1	0	0	0	0	0	0	0	0	1	1	1	1	1	1	1	1
	Yellow	1	1	1	1	1	1	1	1	1	1	1	1	1	1	1	1	0	0	0	0	0	0	0	0
	White	1	1	1	1	1	1	1	1	1	1	1	1	1	1	1	1	1	1	1	1	1	1	1	1
RED	RED (000) Dark	0	0	0	0	0	0	0	0	0	0	0	0	0	0	0	0	0	0	0	0	0	0	0	0
	RED (001)	0	0	0	0	0	0	0	1	0	0	0	0	0	0	0	0	0	0	0	0	0	0	0	0
							
	RED (254)	1	1	1	1	1	1	1	0	0	0	0	0	0	0	0	0	0	0	0	0	0	0	0	0
	RED (255)	1	1	1	1	1	1	1	1	0	0	0	0	0	0	0	0	0	0	0	0	0	0	0	0
GREEN	GREEN (000) Dark	0	0	0	0	0	0	0	0	0	0	0	0	0	0	0	0	0	0	0	0	0	0	0	0
	GREEN (001)	0	0	0	0	0	0	0	0	0	0	0	0	0	0	0	1	0	0	0	0	0	0	0	0
							
	GREEN (254)	0	0	0	0	0	0	0	0	1	1	1	1	1	1	1	0	0	0	0	0	0	0	0	0
	GREEN (255)	0	0	0	0	0	0	0	0	1	1	1	1	1	1	1	1	0	0	0	0	0	0	0	0
BLUE	BLUE (000) Dark	0	0	0	0	0	0	0	0	0	0	0	0	0	0	0	0	0	0	0	0	0	0	0	0
	BLUE (001)	0	0	0	0	0	0	0	0	0	0	0	0	0	0	0	0	0	0	0	0	0	0	0	1
							
	BLUE (254)	0	0	0	0	0	0	0	0	0	0	0	0	0	0	0	0	1	1	1	1	1	1	1	0
	BLUE (255)	0	0	0	0	0	0	0	0	0	0	0	0	0	0	0	0	1	1	1	1	1	1	1	1

Product Specification

3-6. Power Sequence

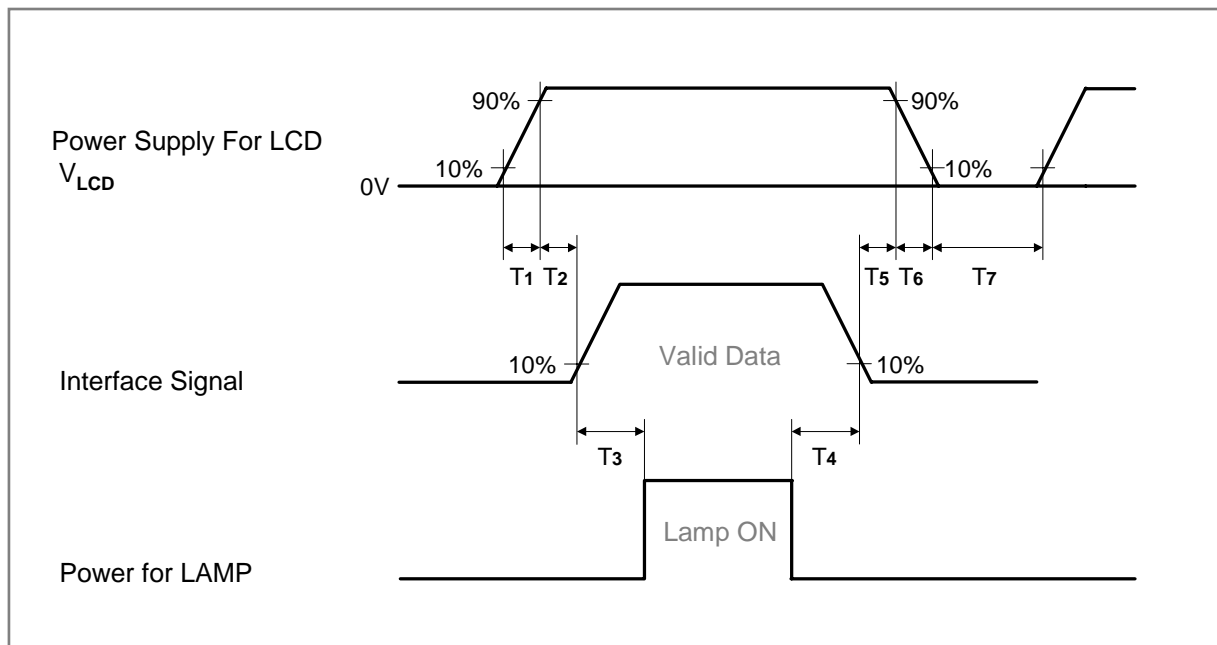

Table 9. POWER SEQUENCE

Parameter	Values			Units
	Min	Typ	Max	
T1	1	-	10	ms
T2	0.5	-	50	ms
T3	200	-	-	ms
T4	200	-	-	ms
T5	0.5	-	50	ms
T6	-	-	10	ms
T7	1	-	-	s

- Notes :
1. Please avoid floating state of interface signal at invalid period.
 2. When the interface signal is invalid, be sure to pull down the power supply for LCD V_{DD} to 0V.
 3. Lamp power must be turn on after power supply for LCD an interface signal are valid.

Product Specification

3-7. LUMINANCE CONTROLS

3.7.1 Luminance Control Method

Method	Adjustment and Luminance Ratio	PWSEL Signal	BRTP Signal	Notes						
Voltage Control	- Adjustment This Control method can carry out continuation adjustment of luminance, If it is adjusted within the rated voltage for BRTI signal(VBI). - Luminance ratio(these data are the target values) <table border="1" data-bbox="297 630 841 744"> <thead> <tr> <th>BTRI Voltage(VBI)</th> <th>Luminance ratio</th> </tr> </thead> <tbody> <tr> <td>0V</td> <td>20%(Minimum)</td> </tr> <tr> <td>3.3V</td> <td>100%(Maximum)</td> </tr> </tbody> </table>	BTRI Voltage(VBI)	Luminance ratio	0V	20%(Minimum)	3.3V	100%(Maximum)	High or Open	Open	
BTRI Voltage(VBI)	Luminance ratio									
0V	20%(Minimum)									
3.3V	100%(Maximum)									
Pulse Width Modulation	- Adjustment Pulse Width Modulation(PWM) method works, when PWSEL signal is Low and PWM signal(BRTP Signal) is inputted into BRTP terminal. The luminance is controlled by duty ratio of BRTP signal. - Luminance ratio(these data are the target values) <table border="1" data-bbox="297 1058 841 1172"> <thead> <tr> <th>Duty ratio</th> <th>Luminance ratio</th> </tr> </thead> <tbody> <tr> <td>0.2</td> <td>20%(Minimum)</td> </tr> <tr> <td>1.0</td> <td>100%(Maximum)</td> </tr> </tbody> </table>	Duty ratio	Luminance ratio	0.2	20%(Minimum)	1.0	100%(Maximum)	Low	PWM Signal	1
Duty ratio	Luminance ratio									
0.2	20%(Minimum)									
1.0	100%(Maximum)									

Notes : 1. See "3.7.2 Detail of PWM timing

2. The interference noise of luminance control frequency may appear on a display when investigating the matching characteristics. If display noises appear on the display image, the discussion with LPL should be done prior to implementation.

Product Specification

3.7.2 Detail of PWM Timing

3.7.2.1 Timing diagram

- Outline chart

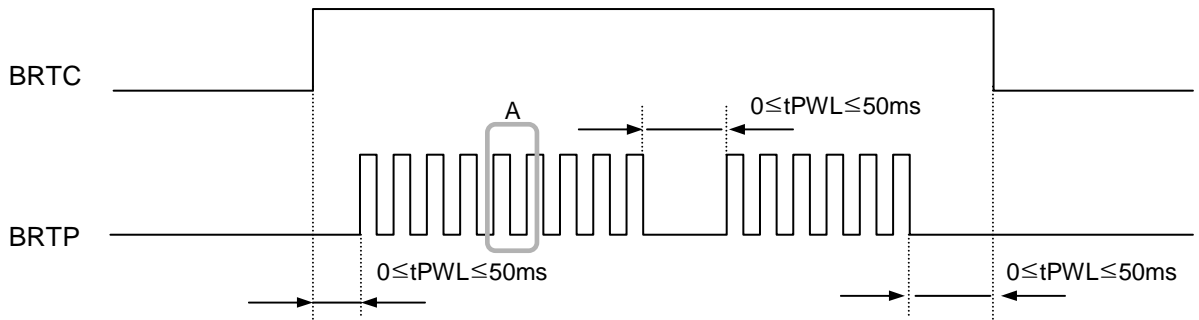

- Detail of A part

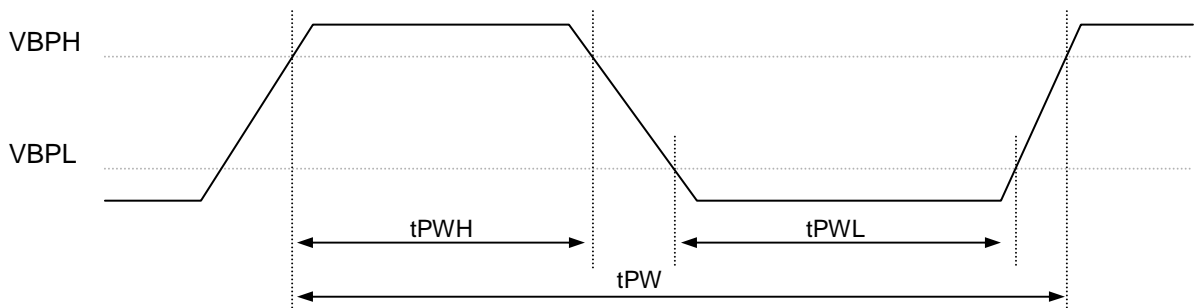

3.7.2.2 Each parameter

Parameter	Symbol	Min.	Typ.	Max.	Unit	Notes
Luminance control frequency	FL	230	255	280	Hz	1, 2
Duty Ratio	DL	0.2	-	1.0	-	1, 3
Non signal Period	tPWL	0	-	50	Ms	4

Notes : 1. Definition of parameters is as follows

$$FL = \frac{1}{t_{PW}} \quad , \quad DL = \frac{t_{PWH}}{t_{PW}}$$

2. See the following formula for luminance control frequency.

$$\text{Luminance control frequency} = tvv \times (n+0.25) \text{ [or } (n+0.72)]$$

$n=1,2,3,\dots$

tvv : See "3.3 Signal timing specification"

The interference noise of luminance control frequency and input signal frequency for LCD panel signal processing board may appear on a display. Set up luminance control frequency so that the interference noise does not appear.

3. See "3.7.1 Luminance control methods"

4. If tPWL is more than 50ms, the backlight will be turned off by a protection circuit for inverter.

Product Specification

4. Optical Specification

Optical characteristics are determined after the unit has been 'ON' and stable for approximately 2Hrs in a dark environment at 25 °C. The values specified are at an approximate distance 50cm from the LCD surface at a viewing angle of Φ and θ equal to 0°.

FIG. 1 presents additional information concerning the measurement equipment and method.

FIG. 1 Optical Characteristic Measurement Equipment and Method

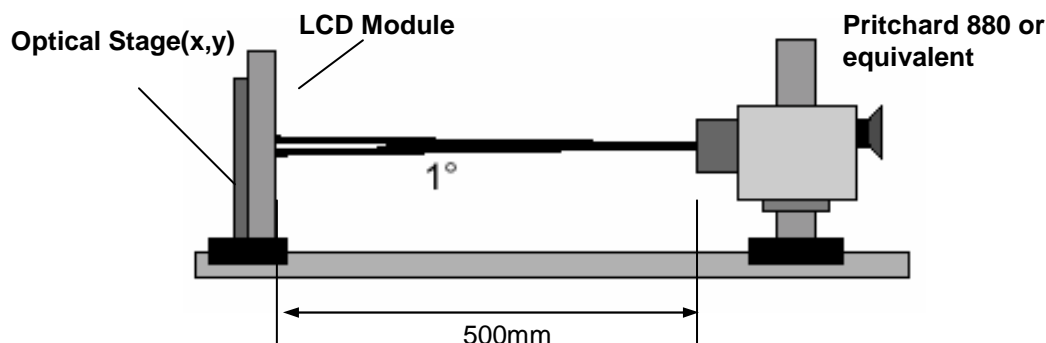

$T_a: 25 \pm 2$ °C, $V_{LCD}: 12.0V$, $f_v: 60Hz$,
 $Dclk: 80MHz$, Luminance Ratio: 100%

Table 10. OPTICAL CHARACTERISTICS

Parameter	Symbol	Values			Units	Notes
		Min	Typ	Max		
Contrast Ratio	CR	-	400			1
Surface Luminance, white	L_{WH}	-	450		cd/m ²	2
Luminance Variation	δ_{WHITE} 5P		-	1.3		3
Response Time	Rise Time		13		ms	4
	Decay Time		12			
Color Coordinates						
	RED	RX	Typ -0.03	0.624	Typ +0.03	
		RY		0.322		
	GREEN	GX		0.290		
		GY		0.581		
	BLUE	BX		0.146		
		BY		0.064		
	WHITE	WX		0.289		
	WY	0.304				
Viewing Angle (CR>10)						
	x axis, right($\phi=0^\circ$)	θ_r	-	85	degree	5
	x axis, left ($\phi=180^\circ$)	θ_l	-	85		
	y axis, up ($\phi=90^\circ$)	θ_u	-	85		
	y axis, down ($\phi=270^\circ$)	θ_d	-	85		
Gray Scale			2.2			6

Product Specification

Notes : 1. Contrast Ratio(CR) is defined mathematically as :

$$\text{Contrast Ratio} = \frac{\text{Surface Luminance with all white pixels}}{\text{Surface Luminance with all black pixels}}$$

2. Surface luminance is the center point(1) across the LCD surface 50cm from the surface with all pixels displaying white under the condition of $I_{BL}=6mArms$. For more information see FIG 1.

3. The variation in surface luminance , δ WHITE is defined by measuring LON at watch test position 1 through 5, and then dividing maximum LON of 5 points luminance by minimum LON of each 5points luminance. For more information see FIG 2.

$$\delta \text{ WHITE} = \text{Maximum (LON1, LON2,, LON5) / Minimum (LON1, LON2,, LON5)}$$

4. Response time is the time required for the display to transition from black to white (Rise Time, TrR) and from white to black (Decay Time, TrD). For additional information see FIG 3.

5. Viewing angle is the angle at which the contrast ratio is greater than 10. The angles are determined for the horizontal or x axis and the vertical or y axis with respect to the z axis which is normal to the LCD surface. For more information see FIG 4.

6. Gray scale specification

Gray Level	Luminance [%] (Typ)
	TYP
L0	0.3
L15	0.65
L31	1.2
L47	2.5
L63	4.68
L79	7.8
L95	11.7
L111	16.0
L127	21.2
L143	27.7
L159	35.2
L175	43.5
L191	53.0
L207	63.7
L223	75.4
L239	86.4
L255	100

Product Specification

FIG. 2 Luminance

<measuring point for surface luminance & measuring point for luminance variation>

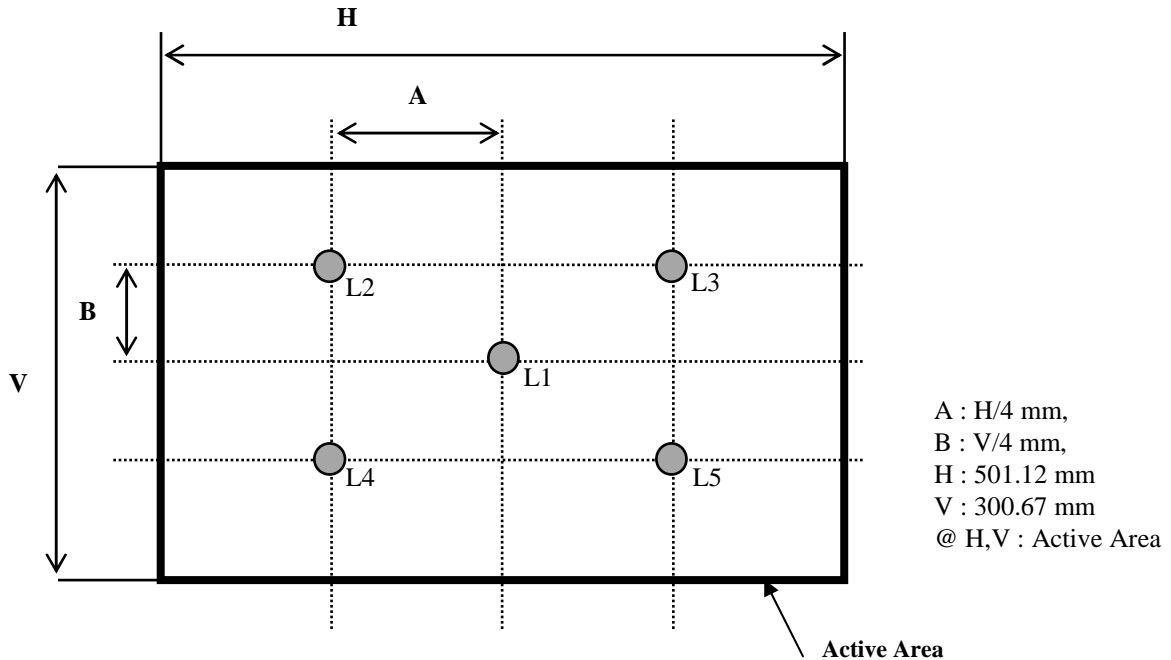
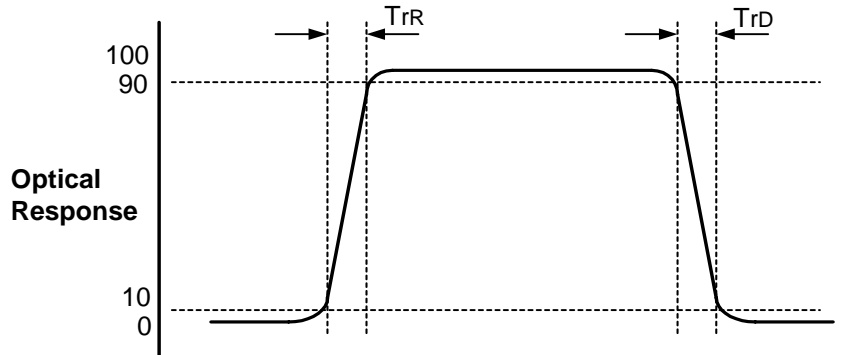

FIG. 3 Response Time

The response time is defined as the following figure and shall be measured by switching the input signal for "black" and "white".



Product Specification

FIG. 4 Viewing angle

<Dimension of viewing angle range>

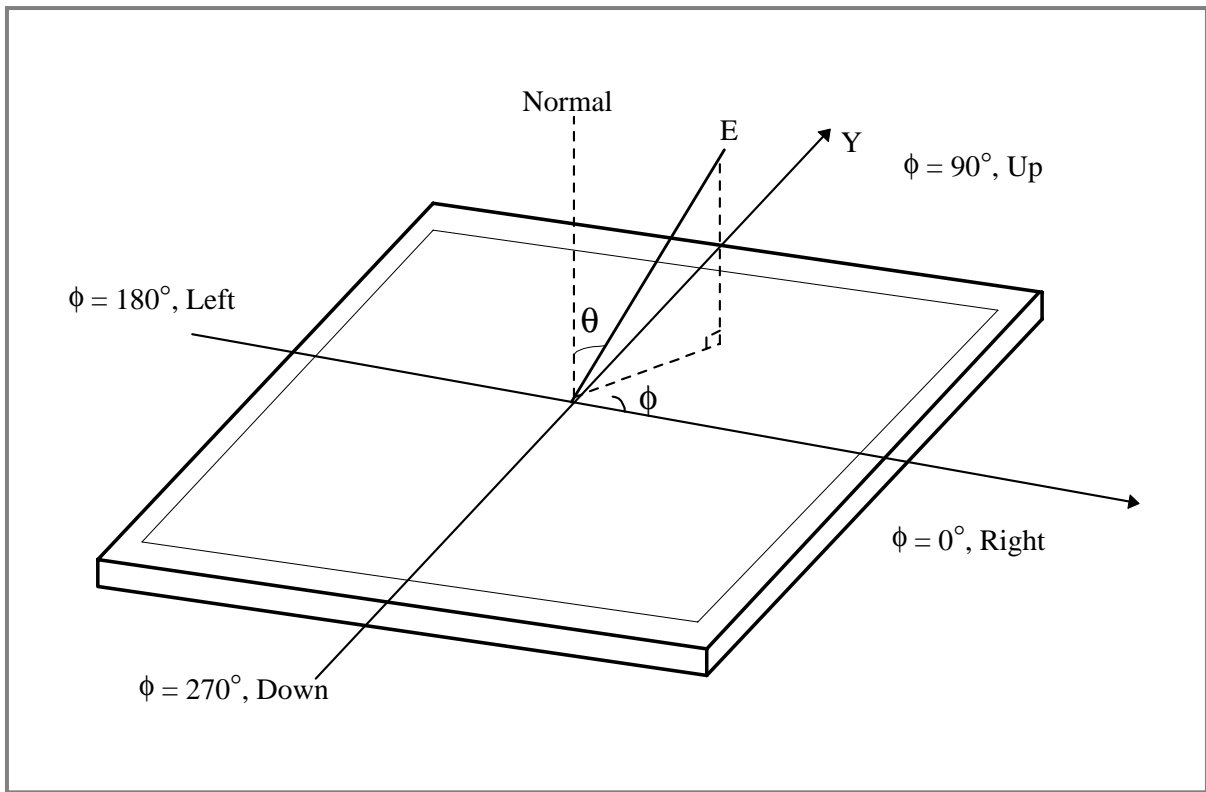

Product Specification
5. Mechanical Characteristics

The contents provide general mechanical characteristics for the model LC230W01. In addition the figures in the next page are detailed mechanical drawing of the LCD.

Outline Dimension	Horizontal	528.0mm
	Vertical	326.0mm
	Depth	34.5mm
Bezel Area	Horizontal	506.0mm
	Vertical	305.6mm
Active Display Area	Horizontal	501.12mm
	Vertical	300.67mm
Weight	3,000g (Typ.) , 3050 (Max.)	
Surface Treatment	Hard coating(3H) Anti-glare treatment of the front polarizer	

Note : See Attached Drawing(Front / Rear View)

Product Specification

<FRONT VIEW>

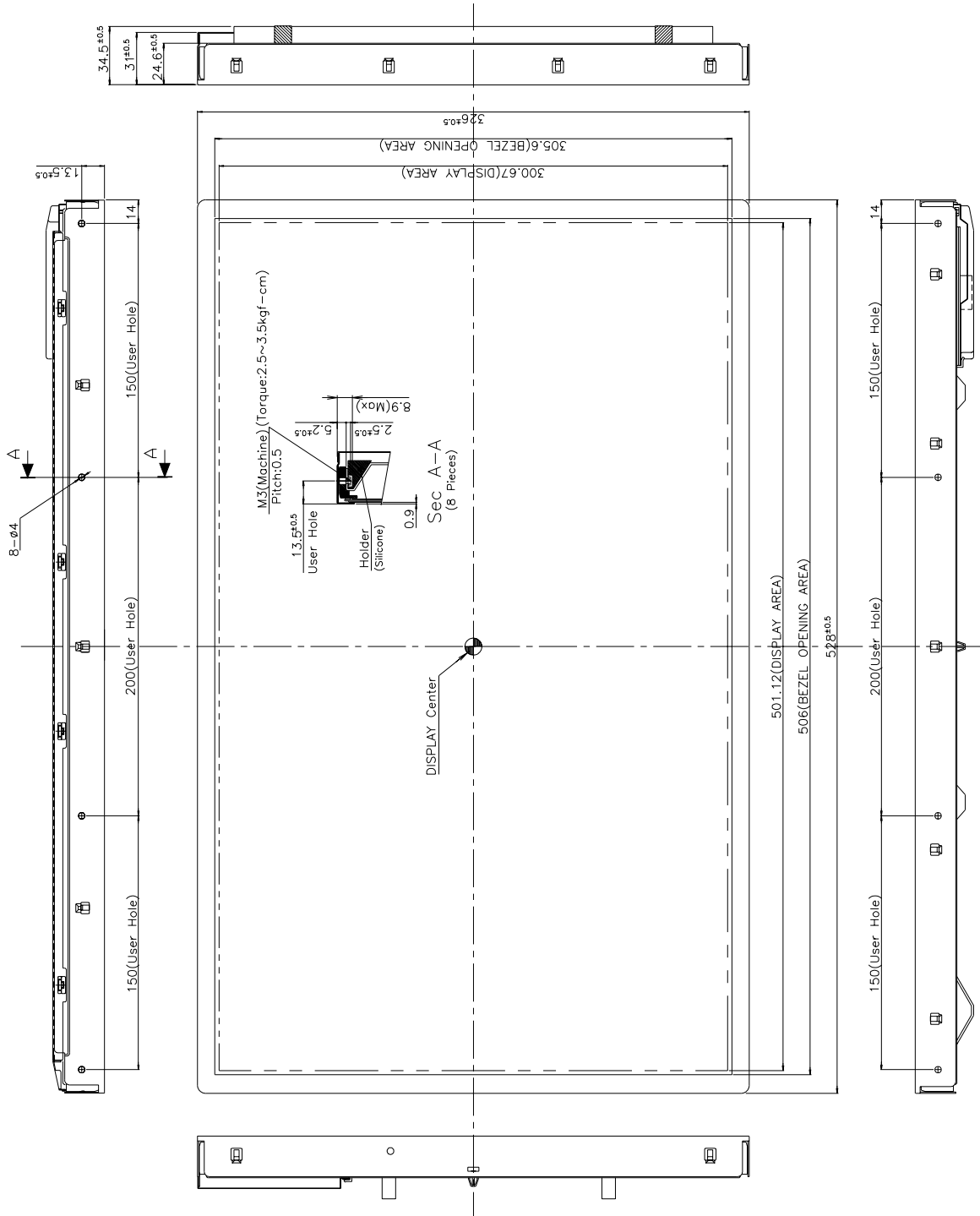

Product Specification

6. Reliability

Environment test condition

No	Test Item	Condition
1	High temperature storage test	Ta= 50°C 240h
2	Low temperature storage test	Ta= -20°C 240h
3	High temperature operation test	Ta= 40°C 50%RH 240h
4	Low temperature operation test	Ta= 0°C 240h
5	Vibration test (non-operating)	Wave form : random Vibration level : 1.0Grms Bandwidth : 10-500Hz Duration : X,Y,Z, 10 min One time each direction
6	Shock test (non-operating)	Shock level : 100Grms Waveform : half sine wave, 2ms Direction : ± X, ± Y, ± Z One time each direction
7	Humidity condition Operation	Ta= 40 °C ,90%RH
8	Altitude operating storage / shipment	0 - 14,000 feet(4267.2m) 0 - 40,000 feet(12192m)

Product Specification**7. International Standards****7-1. Safety**

- a) UL 1950 Third Edition, Underwriters Laboratories, Inc. Jan. 28, 1995.
Standard for Safety of Information Technology Equipment Including Electrical Business Equipment.
- b) CAN/CSA C22.2 No. 950-95 Third Edition, Canadian Standards Association, Jan. 28, 1995.
Standard for Safety of Information Technology Equipment Including Electrical Business Equipment.
- c) EN 60950 : 1992+A1: 1993+A2: 1993+A3: 1995+A4: 1997+A11: 1997
IEC 950 : 1991+A1: 1992+A2: 1993+A3: 1995+A4: 1996
European Committee for Electrotechnical Standardization(CENELEC)
EUROPEAN STANDARD for Safety of Information Technology Equipment Including Electrical Business
Equipment.

7-2. EMC

- a) ANSI C63.4 "Methods of Measurement of Radio-Noise Emissions from Low-Voltage Electrical and Electrical Equipment in the Range of 9kHz to 40GHz. "American National Standards Institute(ANSI), 1992
- b) C.I.S.P.R "Limits and Methods of Measurement of Radio Interface Characteristics of Information Technology Equipment." International Special Committee on Radio Interference.
- c) EN 55022 "Limits and Methods of Measurement of Radio Interface Characteristics of Information Technology Equipment." European Committee for Electrotechnical Standardization.(CENELEC), 1998

Product Specification

8. Packing

8-1. Designation of Lot Mark

a) Lot Mark

A	B	C	D	E	F	G	H	I	J	K	L	M
---	---	---	---	---	---	---	---	---	---	---	---	---

A,B,C : SIZE

D : YEAR

E : MONTH

F,G : PANEL CODE

H : ASSEMBLY CODE

I,J,K,L,M : SERIAL NO.

Note

1. YEAR

Year	97	98	99	2000	2001	2002	2003	2004	2005	2006	2007
Mark	7	8	9	0	1	2	3	4	5	6	7

2. MONTH

Month	Jan	Feb	Mar	Apr	May	Jun	Jul	Aug	Sep	Oct	Nov	Dec
Mark	1	2	4	4	5	6	7	8	9	A	B	C

3. Serial No.

Year	1 ~ 99999	100000 ~
Mark	00001 ~ 99999	A0001 ~ A9999, , Z9999

b) Location of Lot Mark

Serial NO. is printed on the label. The label is attached to the backside of the LCD module.
 This is subject to change without prior notice.

8-2. Packing Form

a) Package quantity in one box : 3 pcs

b) Box Size : 488mm X 245mm X 657mm

9. PRECAUTIONS

Please pay attention to the followings when you use this TFT LCD module.

9-1. MOUNTING PRECAUTIONS

- (1) You must mount a module using holes arranged in four corners or four sides.
- (2) You should consider the mounting structure so that uneven force (ex. Twisted stress) is not applied to the module. And the case on which a module is mounted should have sufficient strength so that external force is not transmitted directly to the module.
- (3) Please attach the surface transparent protective plate to the surface in order to protect the polarizer. Transparent protective plate should have sufficient strength in order to resist external force.
- (4) You should adopt radiation structure to satisfy the temperature specification.
- (5) Acetic acid type and chlorine type materials for the cover case are not desirable because the former generates corrosive gas of attacking the polarizer at high temperature and the latter causes circuit break by electro-chemical reaction.
- (6) Do not touch, push or rub the exposed polarizers with glass, tweezers or anything harder than HB pencil lead. And please do not rub with dust clothes with chemical treatment. Do not touch the surface of polarizer for bare hand or greasy cloth. (Some cosmetics are detrimental to the polarizer.)
- (7) When the surface becomes dusty, please wipe gently with absorbent cotton or other soft materials like chamois soaks with petroleum benzene. Normal-hexane is recommended for cleaning the adhesives used to attach front / rear polarizers. Do not use acetone, toluene and alcohol because they cause chemical damage to the polarizer.
- (8) Wipe off saliva or water drops as soon as possible. Their long time contact with polarizer causes deformations and color fading.
- (9) Do not open the case because inside circuits do not have sufficient strength.

9-2. OPERATING PRECAUTIONS

- (1) The spike noise causes the mis-operation of circuits. It should be lower than following voltage :
 $V = \pm 200\text{mV}$ (Over and under shoot voltage)
- (2) Response time depends on the temperature. (In lower temperature, it becomes longer.)
- (3) Brightness depends on the temperature. (In lower temperature, it becomes lower.)
And in lower temperature, response time (required time that brightness is stable after turned on) becomes longer.
- (4) Be careful for condensation at sudden temperature change. Condensation makes damage to polarizer or electrical contacted parts. And after fading condensation, smear or spot will occur.
- (5) When fixed patterns are displayed for a long time, remnant image is likely to occur.
- (6) Module has high frequency circuits. Sufficient suppression to the electromagnetic interference shall be done by system manufacturers. Grounding and shielding methods may be important to minimize the interference.
- (7) Please do not give any mechanical and/or acoustical impact to LCM. Otherwise, LCM can not be operated its full characteristics perfectly.
- (8) A screw which is fastened up the steels should be a machine screw (if not, it causes metal foreign material and deal LCM a fatal blow)

9-3. ELECTROSTATIC DISCHARGE CONTROL

Since a module is composed of electronic circuits, it is not strong to electrostatic discharge. Make certain that treatment persons are connected to ground through wrist band etc. And don't touch interface pin directly.

9-4. PRECAUTIONS FOR STRONG LIGHT EXPOSURE

Strong light exposure causes degradation of polarizer and color filter.

9-5. STORAGE

When storing modules as spares for a long time, the following precautions are necessary.

- (1) Store them in a dark place. Do not expose the module to sunlight or fluorescent light. Keep the temperature between 5°C and 35°C at normal humidity.
- (2) The polarizer surface should not come in contact with any other object.
It is recommended that they be stored in the container in which they were shipped.

9-6. HANDLING PRECAUTIONS FOR PROTECTION FILM

- (1) The protection film is attached to the bezel with a small masking tape.
When the protection film is peeled off, static electricity is generated between the film and polarizer. This should be peeled off slowly and carefully by people who are electrically grounded and with well ion-blown equipment or in such a condition, etc.
- (2) When the module with protection film attached is stored for a long time, sometimes there remains a very small amount of glue still on the bezel after the protection film is peeled off.
- (3) You can remove the glue easily. When the glue remains on the bezel surface or its vestige is recognized, please wipe them off with absorbent cotton waste or other soft material like chamois soaked with normal -hexane.