



# SPECIFICATION

## FOR

## APPROVAL

( ◆ ) Preliminary Specification

( ) Final Specification

Title	18.1" SXGA TFT LCD
-------	--------------------

BUYER	
MODEL	

SUPPLIER	LG LCD Inc.
MODEL	LM181E3-A2

SIGNATURE	DATE
/	
/	
/	

APPROVED BY	DATE
REVIEWED BY	
PREPARED BY	

Please return 1 copy for your confirmation with your signature and comments.

Product Engineering Dept.  
LG LCD Inc.

**Product Specification****CONTENTS**

<b>NO.</b>	<b>ITEM</b>	<b>Page</b>
-	COVER	1
-	CONTENTS	2
-	RECORD OF REVISION	3
1	GENERAL DESCRIPTION	4
2	MAXIMUM RATINGS	5
3	ELECTRICAL SPECIFICATIONS	6
3-1	ELECTRICAL CHARACTERISTICS	6
3-2	INTERFACE CONNECTION	7
3-3	SIGNAL TIMING SPECIFICATIONS	9
3-4	SIGNAL TIMING WAVE FORMS	10
3-5	COLOR INPUT DATA REFERENCE	11
3-6	POWER SEQUENCE	12
4	OPTICAL SPECIFICATIONS	13
5	MECHANICAL CHARACTERISTICS	15
6	RELIABILITY	18
7	INTERNATIONAL STANDARDS	19
7-1	SAFETY	19
7-2	EMC	19
8	PACKING	20
8-1	DESIGNATION OF LOT MARK	20
8-2	PACKING FORM	20
9	PRECAUTIONS	21
	APPENDIX	23
A-1	OPTICAL CHARACTERISTIC MEASUREMENT EQUIPMENT AND METHOD	23
A-2	LUMINANCE	23
A-3	RESPONSE TIME	23
A-4	VIEWING ANGLE	24



**Product Specification**

**RECORDS OF REVISIONS**

Version No	Date	Page	DESCRIPTION
0.0	May 4, 1999	-	First Draft



Product Specification

1. General Description

The LG LCD model LM181E3-A2 is a Color Active Matrix Liquid Crystal Display with an integral Cold Cathode Fluorescent Tube(CCFT) back light system. The matrix employs a-Si Thin Film Transistor as the active element. It is a transmissive type display operating in the normally black mode. This TFT-LCD has a 18.1 inch diagonally measured active display area with SXGA resolution(1024 vertical by 1280 horizontal pixel array). Each pixel is divided into Red, Green and Blue sub-pixels or dots which are arranged in vertical stripes. Gray scale or the brightness of the sub-pixel color is determined with a 8-bit gray scale signal for each dot, thus, presenting a palette of more than 16,777,216 colors.

The LM181E3-A2 has been designed to apply the interface method that enables low power, high speed low EMI. FPD Link must be used as a LVDS(Low Voltage Differential Signaling) chip.

The LM181E3-A2 is intended to support applications where thin thickness, wide viewing angle, low power are critical factors and graphic displays are important. In combination with the vertical arrangement of the sub-pixels, the LM181E3-A2 characteristics provide an excellent flat panel display for office automation products such as monitors.

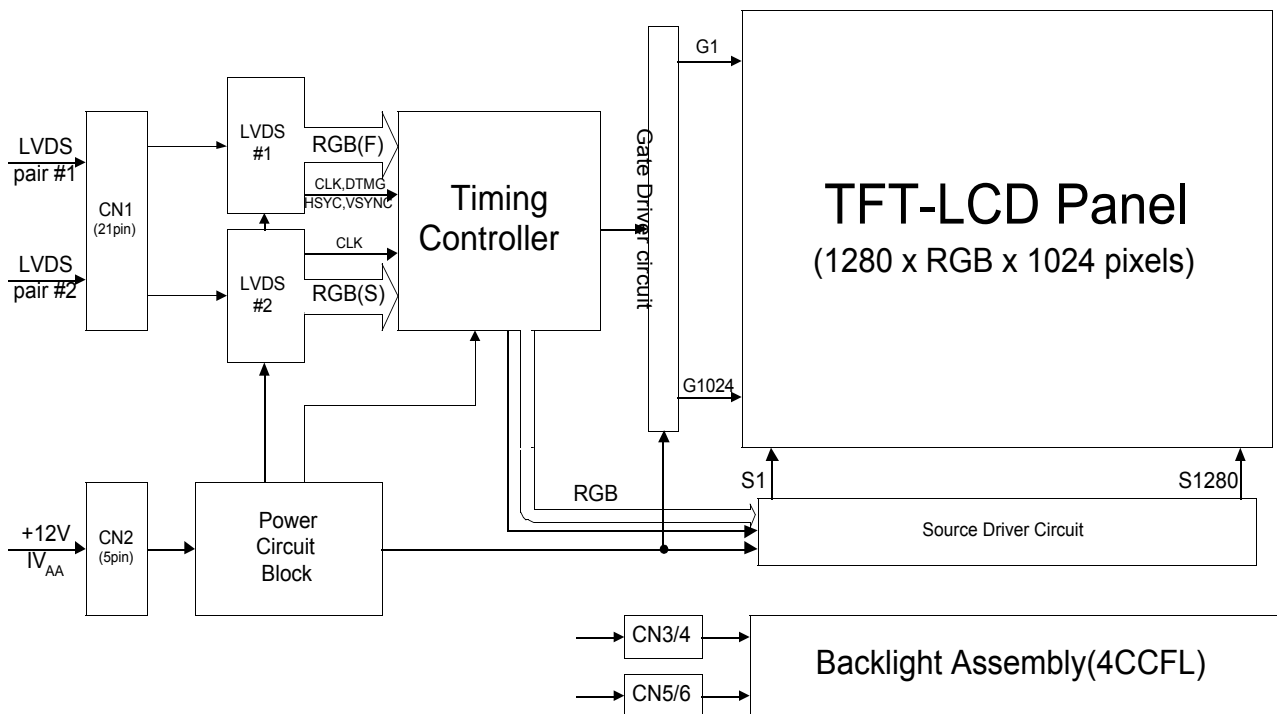

General Features

- The following are general feature of the model LM181E3-A2 LCD;
- Active screen size 18.1 inches(45.97cm) diagonal
- Outline dimensions 412.5(H) □ 333.0(V) □ 22.5(D) mm (typ)
- Pixel pitch 0.2805 mm □ 0.2805 mm
- Pixel format 1280 horiz. By 1024 vert. pixels
- RGB stripe arrangement
- Color depth 8-bit, 16,777,216 colors
- Luminance,White 220 cd/m<sup>2</sup> (typ)
- Power Consumption Total 29.16Watt,typ (6.6Watt @IV<sub>AA</sub>, 22.56Watt@200 cd/m<sup>2</sup>,Lamp)
- Weight 2835 (typ)
- Display operating mode transmissive mode, normally black
- Surface treatments hard coating(3H), anti-glare treatment of the front polarizer



Product Specification

2. Maximum Ratings

The following are maximum values which, if exceeded, may cause faulty operation or damage to the unit.

Table 1. ABSOLUTE MAXIMUM RATINGS

Parameter	symbol	Values		Units	Notes
		Min.	Max.		
Power Input Voltage	$V_{AA}$	-0.3	+13.2	Vdc	at 25°
Operating Temperature	$T_{OP}$	5	+50	°C	1
Storage Temperature	$T_{ST}$	-10	+60	°C	1

Note: 1. Temperature and relative humidity range are shown in the figure below.

Relative Humidity (% RH)

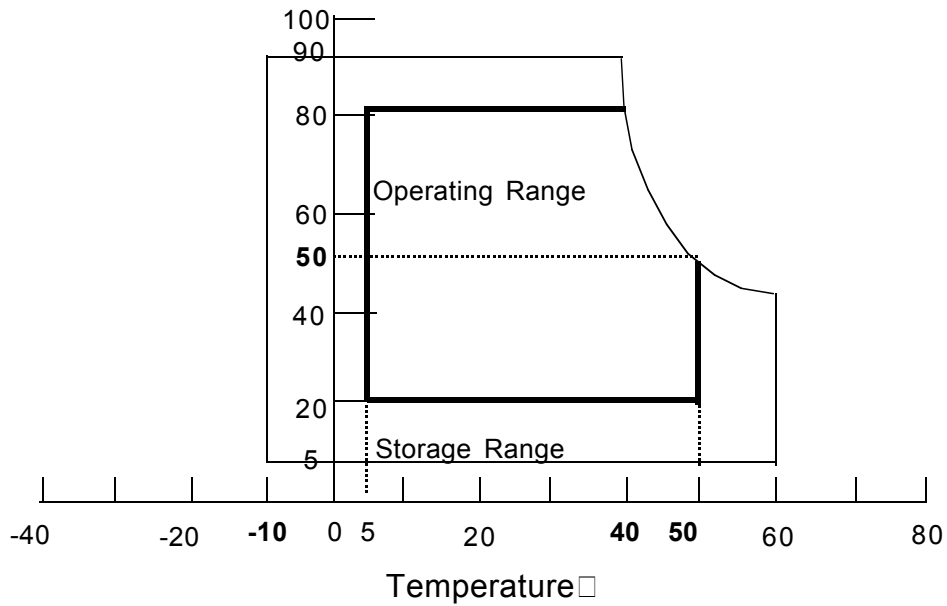



Product Specification

3. Electrical Specifications

3-1. Electrical Characteristics

The LM181E3-A2 requires two power inputs. One is employed to power the LCD electronics and to drive the TFT array and liquid crystal. The other input which powers the CCFL, is typically generated by an inverter. The inverter is an external unit to the LCD.

Table 2. ELECTRICAL CHARACTERISTICS

Parameter	Symbol	Values			Units	Notes
		Min.	Typ.	Max.		
<b>MODULE:</b>						
Power Supply Input Voltage	$I_{V_{AA}}$	11.2	12.0	12.6	Vdc	
Power Supply Input Current	$I_{CC}$	-	0.55	0.9	A	1
Power Consumption	$P_c$	-	6.6	10.8	Watts	1
<b>LAMP</b>						
Operating Voltage	$V_{BL}$	634	705	776	$V_{RMS}$	2
Operating Current	$I_{BL}$	-	8.0	8.5	mA	
Established Starting Voltage		at 25□	1250	-	$V_{RMS}$	3
		at 0□	1550	-	$V_{RMS}$	
Operating Frequency	$f_{BL}$	30	-	60	kHz	
Power Consumption	$P_{BL}$	-	22.56	-	Watts	4
Life Time		20,000	30,000		Hrs	5

- Notes: 1. The current draw and power consumption specified is for 12.0 Vdc at 25□ and fv at 60Hz. (at 8-gray pattern displayed)
2. The variance of the voltage is □10%.
3. The output voltage at the transformer in the inverter must be high considering to the loss of the ballast capacitor in the inverter.
4. The lamp power consumption shown above does not include loss of external inverter.
5. The life time is determined as the time at which brightness of lamp is 50% compare to that of initial value at the typical lamp current



Product Specification

3-2. Interface Connections

Interface chip must be used LVDS, part No. DS90CF383MTD(Transmitter), DS90CF384MTD(Receiver) made by National Semiconductor. Or used the compatible interface chips(TI : SN75LVDS83, Thine).

This LCD employs six interface connections. A 21-pin connector is used for the module electronics interface. A 5-pin connector is used for the module power(+12V). Four 2-pin connectors are used for the integral backlight system.

The electronics interface connector is a model FI-TWE21P-VF manufactured by JAE. The pin configuration for the connector is shown in the table 3.

Table 3. MODULE CONNECTOR PIN CONFIGURATION (LVDS)

Pin	Symbol	Description	Notes
1	FR3P	Plus Signal of Odd Channel 3 (LVDS)	} <b>First Data</b>
2	FR3M	Minus Signal of Odd Channel 3 (LVDS)	
3	FCLKINP	Plus Signal of Odd Clock Channel (LVDS)	
4	FCLKINM	Minus Signal of Odd Clock Channel (LVDS)	
5	FR2P	Plus Signal of Odd Channel 2 (LVDS)	
6	FR2M	Minus Signal of Odd Channel 2 (LVDS)	
7	FR1P	Plus Signal of Odd Channel 1 (LVDS)	
8	FR1M	Minus Signal of Odd Channel 1 (LVDS)	
9	FR0P	Plus Signal of Odd Channel 0 (LVDS)	
10	FR0M	Minus Signal of Odd Channel 0 (LVDS)	
11	SR3P	Plus Signal of Even Channel 3 (LVDS)	} <b>Second Data</b>
12	SR3M	Minus Signal of Even Channel 3 (LVDS)	
13	SCLKINP	Plus Signal of Even Clock Channel (LVDS)	
14	SCLKINM	Minus Signal of Even Clock Channel (LVDS)	
15	SR2P	Plus Signal of Even Channel 2 (LVDS)	
16	SR2M	Minus Signal of Even Channel 2 (LVDS)	
17	SR1P	Plus Signal of Even Channel 1 (LVDS)	
18	SR1M	Minus Signal of Even Channel 1 (LVDS)	
19	SR0P	Plus Signal of Even Channel 0 (LVDS)	
20	SR0M	Minus Signal of Even Channel 0 (LVDS)	
21	NC	Not Connect	

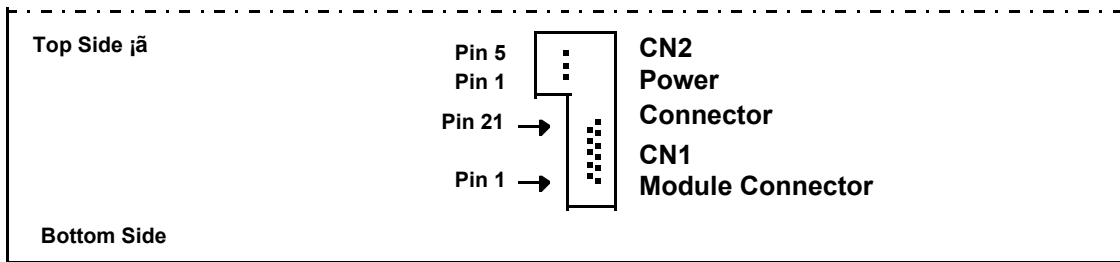

Back side of LCD Module



Product Specification

The module power connector is a model B5B-ZR-SM3-TF manufactured by JST. The pin configuration for the connector is shown in the table 4.

Table 4. POWER CONNECTOR PIN CONFIGURATION

Pin	Symbol	Description	Notes
1	GND	Ground	1
2	GND	Ground	
3	GND	Ground	
4	IV <sub>AA</sub>	Supply voltage for LCD module	2
5	IV <sub>AA</sub>	Supply voltage for LCD module	

- Notes:
1. All GND(ground) pins should be connected together and to Vss which should also be connected to the LCD's metal frame.
  2. All IV<sub>AA</sub>(power input) pins should be connected together.

The backlight interface connector is a model BHSR-02VS-1, manufactured by JST. The mating connector part number is SM02B-BHSS-1 or equivalent. The pin configuration for the connector is shown in the table 5.

Table 5. BACKLIGHT CONNECTOR PIN CONFIGURATION

Pin	Symbol	Description	Notes
1	HV	Lamp power input	1
2	LV	Ground	2

- Notes:
1. The input power terminal is colored pink or white. Ground pin color is white or black.
  2. The lamp ground should be common with GND.

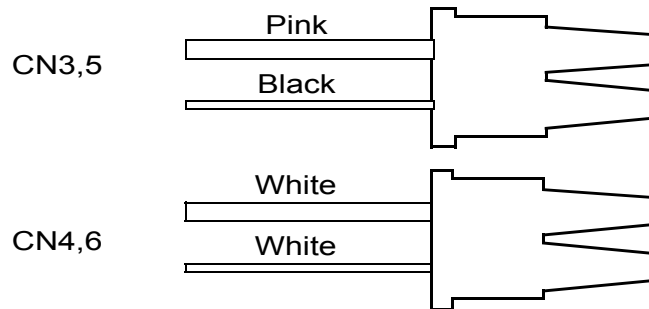



Product Specification

3-3. Signal Timing Specification

This is the signal timing required at the input of the LVDS Transmitter. All of the interface signal timing should be satisfied with the following specifications for its proper operation.

Table 6. Timing Table

ITEM		SYMBOL	MIN.	TYP.	MAX.	UNIT	NOTE
Dclk	Period	t <sub>CLK</sub>	18.5	-	18.5	ns	1
Hsync	Period	t <sub>HP</sub>	760	844	928	t <sub>CLK</sub>	
	Width-Active	t <sub>WH</sub>	8	56	240		
Vsync	Period	t <sub>VP</sub>	1032	1066	1097	t <sub>HP</sub>	
	Width-Active	t <sub>WV</sub>	2	3	24		
DE (Data Enable)	Horizontal Back Porch	t <sub>HBP</sub>	12	124	-	t <sub>CLK</sub>	
	Horizontal Active	-	-	640	-		
	Horizontal Front Porch	t <sub>HFP</sub>	8	24	-		
	Vertical Back Porch	t <sub>VBP</sub>	1	38	-	t <sub>HP</sub>	
	Vertical Active	-	-	1024	-		
	Vertical Front Porch	t <sub>VFP</sub>	1	-	-		

Note 1. Two pixel data are sampled at the same time.

Pixel 0,0	pixel 1,0	pixel 2,0	pixel 3,0			pixel 1278,0	pixel 1279,0
Pixel 0,1	pixel 1,1	pixel 2,1	pixel 3,1			pixel 1278,1	pixel 1279,1
Pixel 0,1023	pixel 1,1023	pixel 2,1023	pixel 3,1023			pixel 1278,1023	pixel 1279,1023



3-4. Signal Timing Wave Form

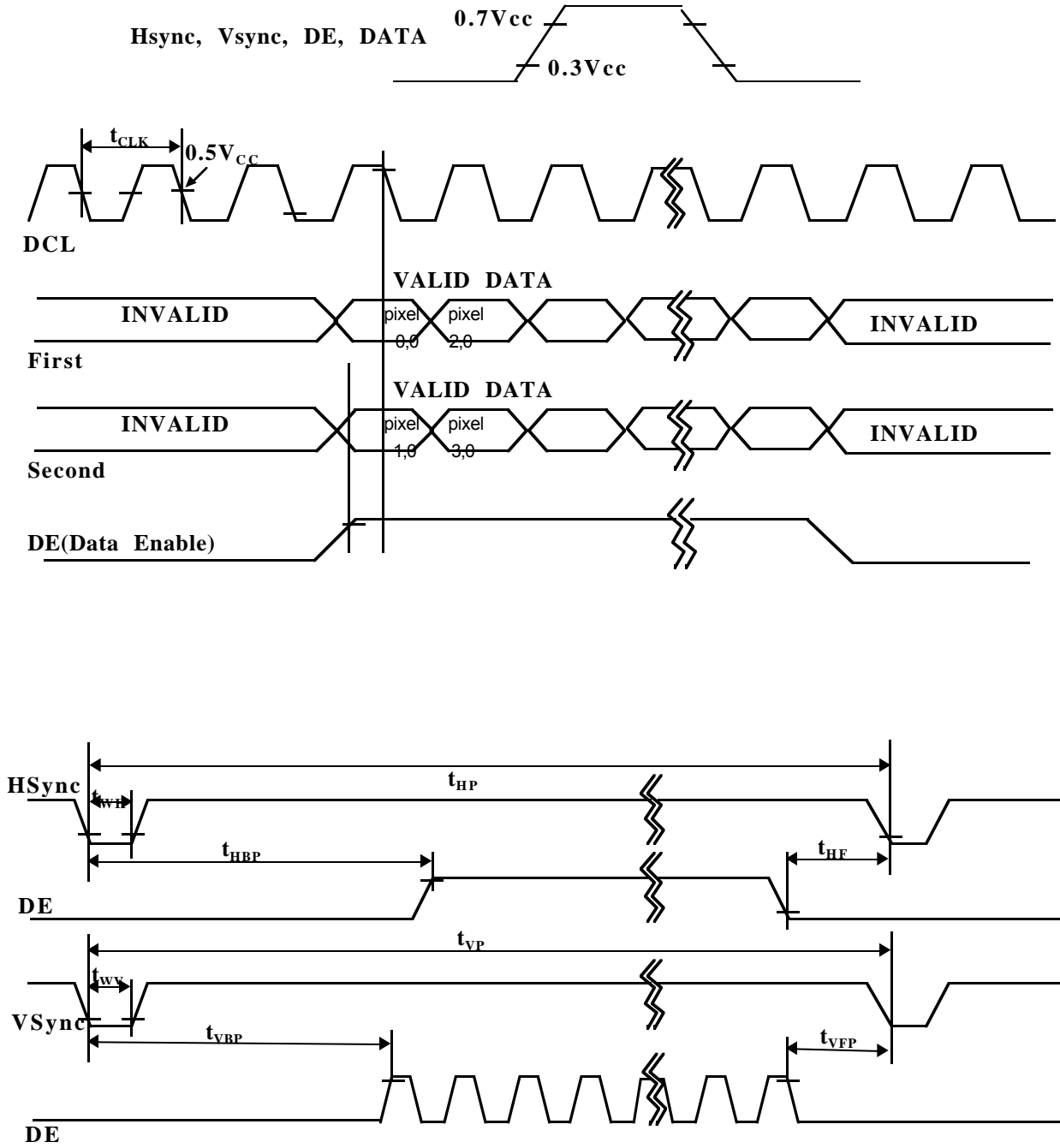



Product Specification

3-5. Color Input Data Reference

The brightness of each primary color(red, green and blue) is based on the 8-bit gray scale data input for the color; the higher the binary input, the brighter the color. The table below provides a reference for color versus data input.

Table 7. COLOR DATA REFERENCE

Color		Input Color Data																							
		Red								Green								Blue							
		MSB				LSB				MSB				LSB				MSB				LSB			
		R7	R6	R5	R4	R3	R2	R1	R0	G7	G6	G5	G4	G3	G2	G1	G0	B7	B6	B5	B4	B3	B2	B1	B0
Basic Colors	Black	0	0	0	0	0	0	0	0	0	0	0	0	0	0	0	0	0	0	0	0	0	0	0	0
	Red(255)	1	1	1	1	1	1	1	1	0	0	0	0	0	0	0	0	0	0	0	0	0	0	0	0
	Green(255)	0	0	0	0	0	0	0	0	1	1	1	1	1	1	1	1	0	0	0	0	0	0	0	0
	Blue(255)	0	0	0	0	0	0	0	0	0	0	0	0	0	0	0	0	1	1	1	1	1	1	1	1
	Cyan	0	0	0	0	0	0	0	0	1	1	1	1	1	1	1	1	1	1	1	1	1	1	1	1
	Magenta	1	1	1	1	1	1	1	1	0	0	0	0	0	0	0	0	1	1	1	1	1	1	1	1
	Yellow	1	1	1	1	1	1	1	1	1	1	1	1	1	1	1	1	0	0	0	0	0	0	0	0
	White	1	1	1	1	1	1	1	1	1	1	1	1	1	1	1	1	1	1	1	1	1	1	1	1
Red	Red(000) Dark	0	0	0	0	0	0	0	0	0	0	0	0	0	0	0	0	0	0	0	0	0	0	0	0
	Red(001)	0	0	0	0	0	0	0	1	0	0	0	0	0	0	0	0	0	0	0	0	0	0	0	0
	Red(002)	0	0	0	0	0	0	1	0	0	0	0	0	0	0	0	0	0	0	0	0	0	0	0	0
	:	:	:	:	:	:	:	:	:	:	:	:	:	:	:	:	:	:	:	:	:	:	:	:	:
	Red(253)	1	1	1	1	1	1	1	0	0	0	0	0	0	0	0	0	0	0	0	0	0	0	0	0
	Red(254)	1	1	1	1	1	1	1	0	0	0	0	0	0	0	0	0	0	0	0	0	0	0	0	0
	Red(255) Bright	1	1	1	1	1	1	1	1	0	0	0	0	0	0	0	0	0	0	0	0	0	0	0	0
Green	Green(000)Dark	0	0	0	0	0	0	0	0	0	0	0	0	0	0	0	0	0	0	0	0	0	0	0	0
	Green(001)	0	0	0	0	0	0	0	0	0	0	0	0	0	0	1	0	0	0	0	0	0	0	0	
	Green(002)	0	0	0	0	0	0	0	0	0	0	0	0	0	0	1	0	0	0	0	0	0	0	0	
	:	:	:	:	:	:	:	:	:	:	:	:	:	:	:	:	:	:	:	:	:	:	:	:	:
	Green(253)	0	0	0	0	0	0	0	0	1	1	1	1	1	1	0	1	0	0	0	0	0	0	0	
	Green(254)	0	0	0	0	0	0	0	0	1	1	1	1	1	1	1	0	0	0	0	0	0	0	0	
	Green(255)Bright	0	0	0	0	0	0	0	0	1	1	1	1	1	1	1	1	0	0	0	0	0	0	0	
Blue	Blue(000) Dark	0	0	0	0	0	0	0	0	0	0	0	0	0	0	0	0	0	0	0	0	0	0	0	0
	Blue(001)	0	0	0	0	0	0	0	0	0	0	0	0	0	0	0	0	0	0	0	0	0	0	0	1
	Blue(002)	0	0	0	0	0	0	0	0	0	0	0	0	0	0	0	0	0	0	0	0	0	0	0	1
	:	:	:	:	:	:	:	:	:	:	:	:	:	:	:	:	:	:	:	:	:	:	:	:	:
	Blue(253)	0	0	0	0	0	0	0	0	0	0	0	0	0	0	0	0	1	1	1	1	1	1	0	1
	Blue(254)	0	0	0	0	0	0	0	0	0	0	0	0	0	0	0	0	1	1	1	1	1	1	1	0
	Blue(255) Bright	0	0	0	0	0	0	0	0	0	0	0	0	0	0	0	0	1	1	1	1	1	1	1	1



Product Specification

3-6. Power Sequences

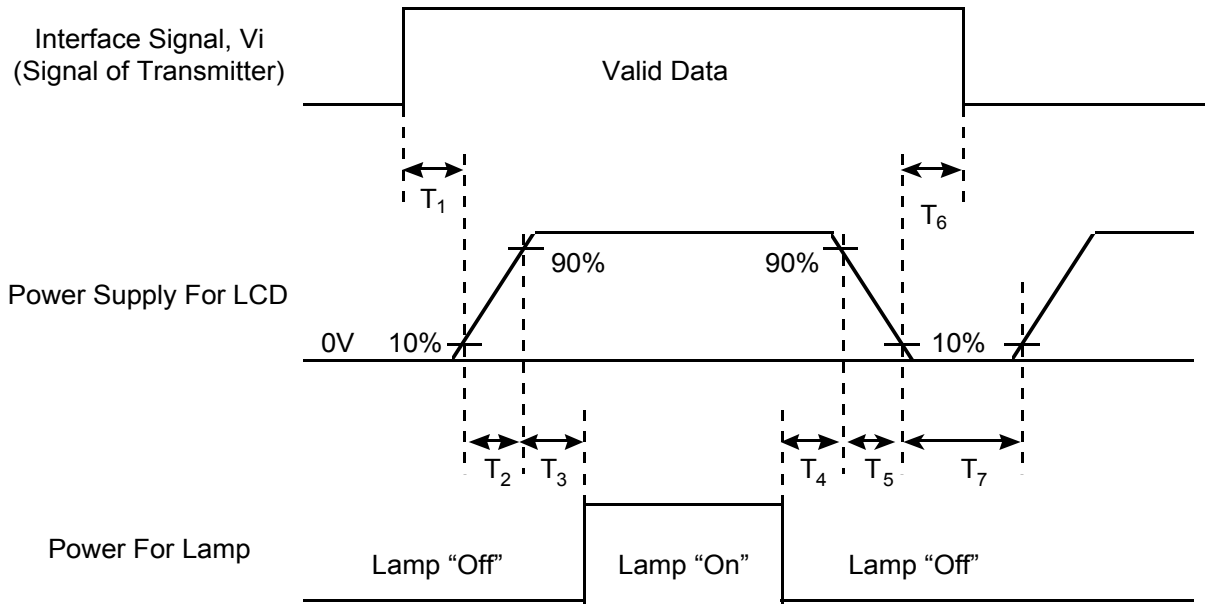

Parameter	Values			Units
	Min.	Typ.	Max.	
$T_1$	50	-	300	ms
$T_2$	-	-	20	ms
$T_3$	100	-	-	ms
$T_4$	100	-	-	ms
$T_5$	0.01	-	-	ms
$T_6$	50	-	300	ms
$T_7$	1	-	-	s

- Notes:
1. Please avoid floating state of interface signal at invalid period.
  2. When the interface signal is invalid, be sure to pull down the power supply for LCD  $V_{CC}$  to 0V. Invalid input with  $IV_{AA}$  for a long time, cause permanent damage to LCD panel.
  3. Lamp power must be turn on after power supply for LCD and interface signal are valid.



Product Specification

4. Optical Specifications

Optical characteristics are determined after the unit has been 'ON' and stable for approximately 30 minutes in a dark environment at 25°. The values specified are at an approximate distance 50cm from the LCD surface at a viewing angle of Φ and θ equal to 0°. Appendix A -1 presents additional information concerning the measurement equipment and method..

Table 8. OPTICAL CHARACTERISTICS

Parameter	Symbol	Values			Units	Notes
		Min.	Typ.	Max.		
Contrast Ratio	CR	200	250	-		1
Surface Luminance, white	L <sub>WH</sub>	200	220	-	cd/m <sup>2</sup>	2
Luminance Variation	□ <sub>WHITE</sub>	-	1.25	1.45		3
Response Time	Tr				msec	4
Rise Time	Tr <sub>R</sub>	-	17	30		
Decay Time	Tr <sub>D</sub>	-	13	20		
CIE Color Coordinates						
Red	x <sub>R</sub>	TBD	TBD	TBD		
	y <sub>R</sub>	TBD	TBD	TBD		
Green	x <sub>G</sub>	TBD	TBD	TBD		
	y <sub>G</sub>	TBD	TBD	TBD		
Blue	x <sub>B</sub>	TBD	TBD	TBD		
	y <sub>B</sub>	TBD	TBD	TBD		
White	x <sub>W</sub>	TBD	TBD	TBD		
	y <sub>W</sub>	TBD	TBD	TBD		
Viewing Angle						
x axis, right (□=0°)	□ <sub>x</sub>	+80	-	-	degree	5
x axis, left(□=180°)	□ <sub>x</sub>	-80	-	-		
y axis, up(□=90°)	□ <sub>y</sub>	+80	-	-		
y axis, down (□=270°)	□ <sub>y</sub>	-80	-	-		
Gamma Value(reference value)			2.3			6

Notes 1. Contrast Ratio (CR) is defined mathematically as :

$$\text{Contrast Ratio} = \frac{\text{Surface Luminance with all white pixels}}{\text{Surface Luminance with all black pixels}}$$

- Surface luminance is the center point across the LCD surface 50cm from the surface with all pixels displaying white. For more information see Appendix A - 2.
- The variation in surface Luminance, □<sub>WHITE</sub> is determined by measuring L<sub>ON</sub> at each test position 1 through 5, and then dividing the maximum L<sub>ON</sub> of 5 points luminance by minimum L<sub>ON</sub> of 5 points luminance. For more information see Appendix A - 2.  
□<sub>WHITE</sub> □ Maximum (L<sub>ON1</sub>, L<sub>ON2</sub>, ....L<sub>ON5</sub>) □ Minimum (L<sub>ON1</sub>, L<sub>ON2</sub>, ....L<sub>ON5</sub>)
- Response time is the time required for the display to transition from white to black (Rise Time, Tr<sub>R</sub>) and from black to white (Decay Time, Tr<sub>D</sub>). For additional information see Appendix A - 3.
- Viewing angle is the angle at which the contrast ratio is greater than 10. The angles are determined for the horizontal or x axis and the vertical or y axis with respect to the z axis



**Product Specification**

which is normal to the LCD surface. For more information see Appendix A - 4

6.Gray scale specification is as following.

Gray Level	Luminance (%)(typ)
L0	TBD
L31	TBD
L63	TBD
L95	TBD
L127	TBD
L159	TBD
L191	TBD
L223	TBD
L255	TBD



**Product Specification**

**5. Mechanical Characteristics**

The chart below provides general mechanical characteristics for the model LM181E3-A2 LCD. In addition, the figure below is a detailed mechanical drawing of the LCD. Note that dimension are given for reference purposes only.

Parameters	Value	unit	Notes
Outside dimensions Horizontal Vertical Depth	412.5 333.0 22.5	mm	-
Bezel area Horizontal Vertical	363.5 292.0	mm	-
Active Display area Horizontal Vertical	359.040 287.232	mm	-
Weight	2835	gram	-
Surface Treatment	Hard coating 3H. Anti-glare treatment of the front polarizer	-	-



Product Specification

< FRONT VIEW >

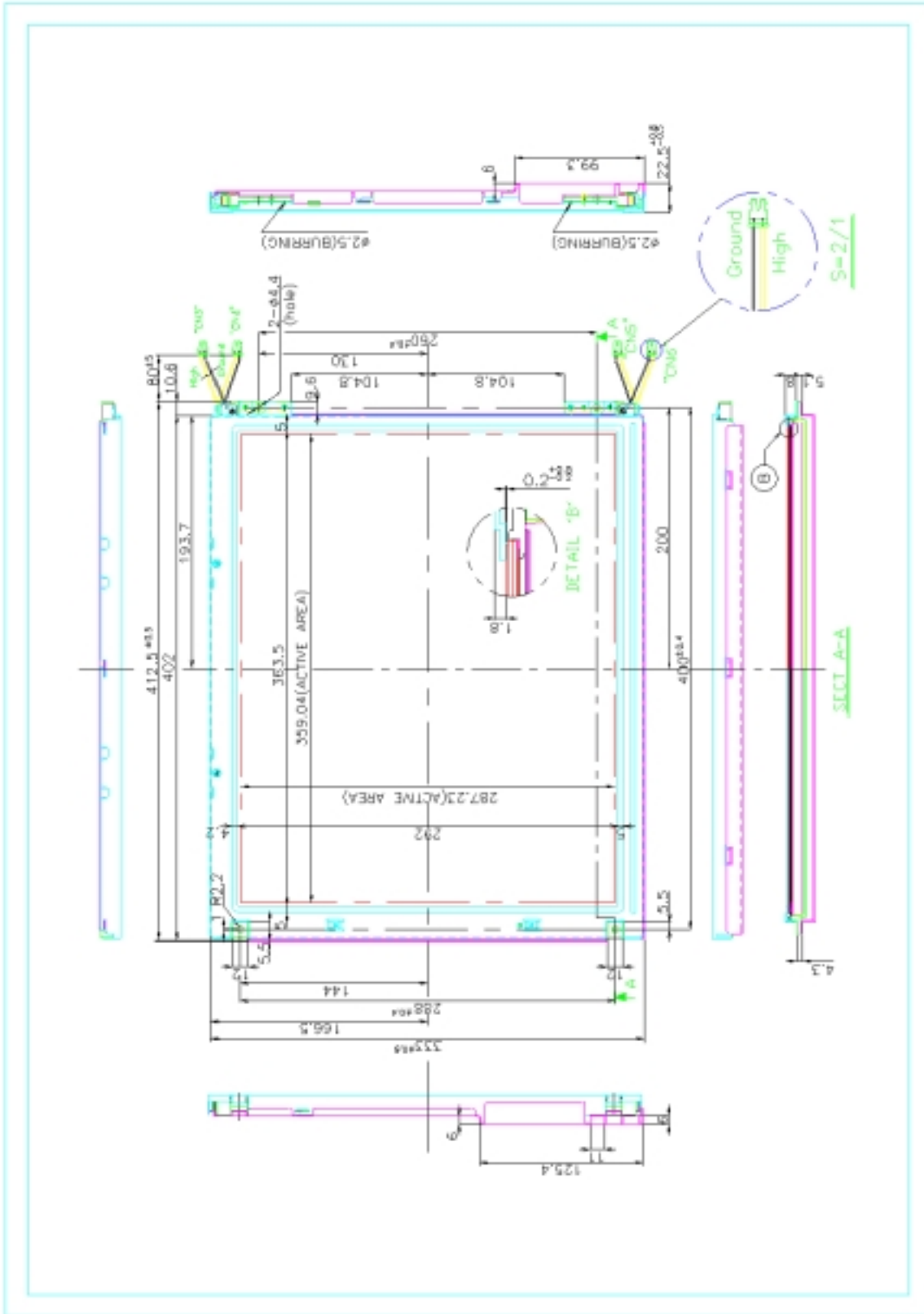



Product Specification

< REAR VIEW >

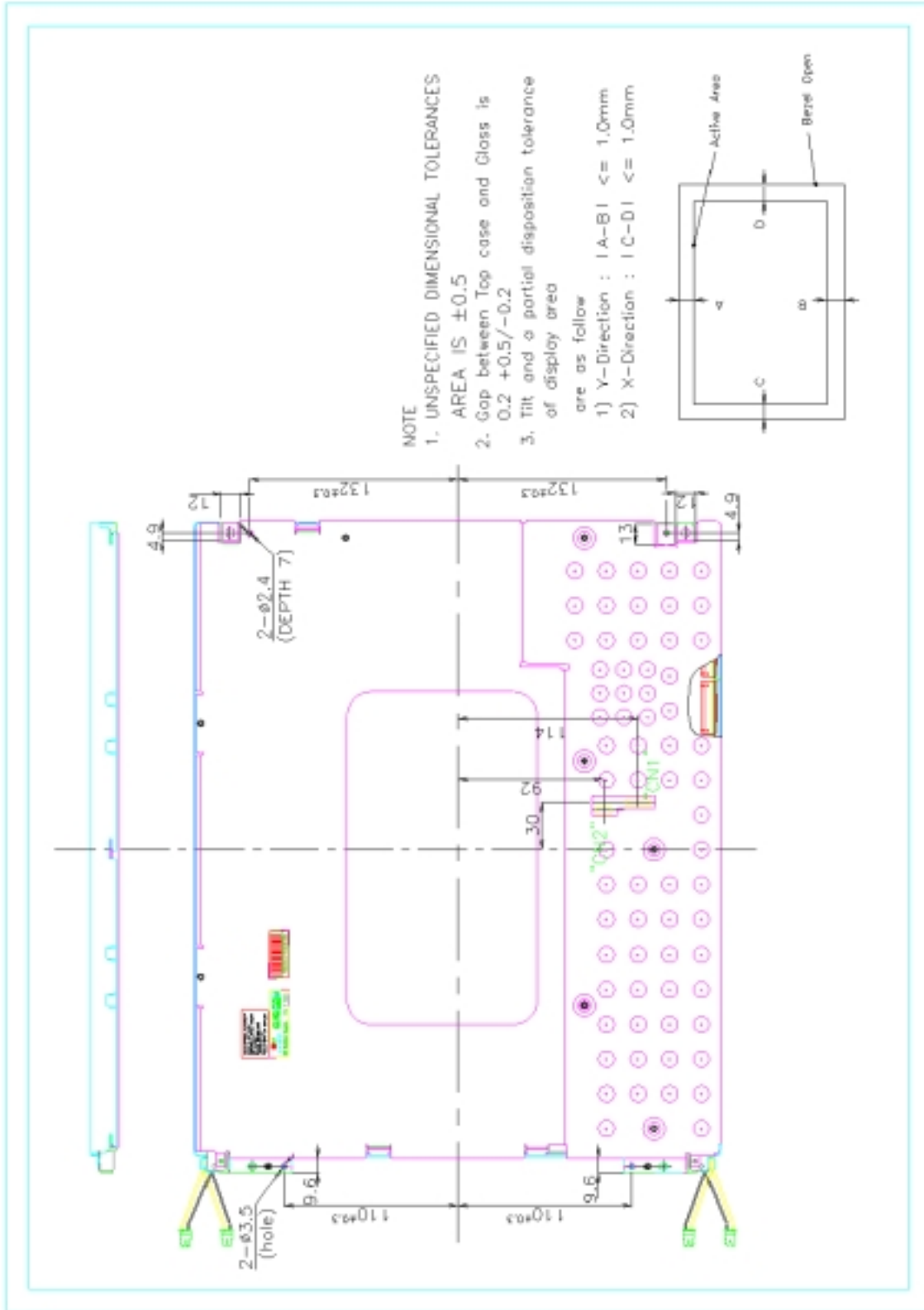



Product Specification

6. Reliability

- Environment test condition

No.	Test ITEM	Conditions
1	High temperature storage test	Ta = 60□ 240h
2	Low temperature storage test	Ta = -10□ 240h
3	High temperature operation test	Ta = 50□ 50%RH 240h
4	Low temperature operation test	Ta = 5□ 240h
5	Vibration test (non-operating)	TBD
6	Shock test (non-operating)	TBD
7	Altitude operating storage/shipment	0 - 10,000 feet (3048m) 0 - 40,000 feet (12192m)
8	Drop test(Packing)	TBD

{Result Evaluation Criteria}

There should be no change which might affect the practical display function when the display quality test is conducted under normal operating condition.



**7. International Standards**

**7-1. Safety**

- a) UL 1950 Third Edition, Underwriters Laboratories, Inc. Jan. 28, 1995.  
Standard for Safety of Information Technology Equipment Including Electrical Business Equipment.
- b) CAN/CSA C22.2 No. 950-95 Third Edition, Canadian Standards Association, Jan. 28, 1995.  
Standard for Safety of Information Technology Equipment Including Electrical Business Equipment.
- c) EN 60950 : 1992 + A1 : 1993 + A2 : 1993 + A3 : 1995 + A4 : 1997 + A11 : 1997  
IEC 950 : 1991 + A1 : 1992 + A2 : 1993 + A3 : 1995 + A4 : 1996  
European Committee for Electrotechnical Standardization (CENELEC)  
EUROPEAN STANDARD for Safety of Information Technology Equipment Including Electrical Business Equipment.

**7-2. EMC**

- a) ANSI C63.4 „Methods of Measurement of Radio-Noise Emissions from Low-Voltage Electrical and Electronic Equipment in the Range of 9kHz to 40GHz.“ American National Standards Institute(ANSI),1992.
- b) C.I.S.P.R „Limits and Methods of Measurement of Radio Interference Characteristics of Information Technology Equipment.“ International Special Committee on Radio Interference
- c) EN 55022 „Limits and Methods of Measurement of Radio Interference Characteristics of Information Technology Equipment.“ European Committee for Electrotechnical Standardization (CENELEC),1988



**Product Specification**

**8. Packaging**

**8-1. Designation of Lot Mark**

a) Lot Mark

A	B	C	D	E	F	G	H	I	J	K	L
---	---	---	---	---	---	---	---	---	---	---	---

A, B, C : MODEL CODE  
D : YEAR  
E : MONTH  
F, G : DIVISION CODE  
H : MODULE LINE  
I, J, K, L, M : SERIAL NO.

Note : 1. YEAR

YEAR	89	90	91	92	93	94	95	96	97	98	99
Mark	9	0	1	2	3	4	5	6	7	8	9

2. MONTH

MONTH	Jan.	Feb.	Mar.	Apr.	May	Jun.	Jun.	Aug.	Sep.	Oct.	Nov.	Dec.
Mark	1	2	3	4	5	6	7	8	9	A	B	C

b) Location of Lot Mark

Serial NO. is printed on the label. The label is attached to the backside of the LCD module.  
This is subject to change without prior notice.

**8-2. Packing Form**

a) Package quantity in one box : 5 pcs

b) Box Size : 524mm□301mm□444mm



**Product Specification**

**9. PRECAUTIONS**

Please pay attention to the followings when you use this TFT/LCD module.

**9.1 MOUNTING PRECAUTIONS**

- (1) You must mount a module user holes arranged in four corners.
- (2) You should consider the mounting structure so that uneven force (ex. twisted stress) is not applied to the module.  
And the case on which a module is mounted should have sufficient strength so that external force is not transmitted directly to the module.
- (3) Please attach the surface with a transparent protective plate in order to protect the polarizer LC cell.  
Transparent protective plate should have sufficient strength in order to resist external force.
- (4) You should adopt radiation structure to satisfy the temperature specification.
- (5) Acetic acid type and chlorine type materials for the cover case are not desirable because the former generates corrosive gas of attacking the polarizer at high temperature and the latter causes circuit break by electro-chemical reaction.
- (6) Do not touch, push or rub the exposed polarizer with glass, tweezers or anything harder than HB pencil head And Please do not rub with dust clothes with chemical treatment.  
Do not touch the surface of polarizer for bare hand or greasy cloth. (Some cosmetics are detrimental to the polarizer.)
- (7) When the surface becomes dusty, please wipe gently with absorbent cotton or other soft materials like chamois soaked with petroleum benzene. Normal-hexane is recommended for cleaning the adhesives used to attach front / rear polarizer. Do not use acetone, toluene and alcohol because they cause chemical damage to the polarizer.
- (8) Wipe off saliva or water drops as soon as possible. Their long time contact with polarizer causes deformations and color fading.
- (9) Do not open the case because inside circuits do not have sufficient strength.

**9.2 OPERATING PRECAUTIONS**

- (1) The spike noise causes the malfunction of circuits. It should be lower than following voltage :  
 $V = \pm 200mV$  (Over and under shoot voltage).
- (2) Response time depends on the temperature. (In lower temperature, it becomes longer.)
- (3) Brightness depends on the temperature. (In lower temperature, it becomes lower.)  
And in lower temperature, response time (required time that brightness is stable after turned on ) becomes longer.
- (4) Be careful for condensation at sudden temperature change. Condensation makes damage to polarizer or electrical contacted parts. And after fading condensation, smear or spot will occur.
- (5) When fixed patterns are displayed for a long time, remnant image is likely to occur.
- (6) A module has high frequency circuit. If you need to shield the electromagnetic noise, please do in yours.
- (7) When a Back-light unit is operating, it sounds. If you need to shield the noise, please do in yours.

**9.3 ELECTROSTATIC DISCHARGE CONTROL**

Since a module is composed of electronic circuits. it is not strong to electrostatic discharge. Make certain that treatment persons are connected to ground through wrist band etc. . . And don't touch I/F pin directly.

**9.4 PRECAUTION FOR STRONG LIGHT EXPOSURE**

Strong light exposure causes degradation of polarizer and color filter.

**9.5 STORAGE**



**Product Specification**

When storing modules as spares for a long time. The following precautions are necessary.

- (1) Store them in a dark place. Do not expose the module to sunlight or fluorescent light. Keep the temperature between 5° and 35° at normal humidity.
- (2) The polarizer surface should not come in contact with any other object.  
It is recommended that they be stored in the container in which they were shipped.

**9.6 HANDLING PRECAUTIONS FOR PROTECTION FILM**

- (1) When the protection film is peeled off, static electricity is generated between the film and polarizer.  
This should be peeled off slowly and carefully by people who are electrically grounded and with well ion- blown equipment or in such a condition, etc..
- (2) The protection film is attached to the polarizer with a small amount of glue. If some stress is applied to rub the protection film against the polarizer during the time you peel off the film, the glue is apt to remain on the polarizer.  
Please carefully peel off the protection film without rubbing it against the polarizer.
- (3) When the module with protection film attached is stored for a long time, sometimes there remains a very small amount of glue still on the polarizer after the protection film is peeled off.
- (4) You can remove the glue easily. When the glue remains on the polarizer surface or its vestige is recognized, please wipe them off with absorbent cotton waste or other soft material like chamois soaked with normal- hexane.



APPENDIX

**A-1 Optical Characteristic Measurement Equipment and Method**

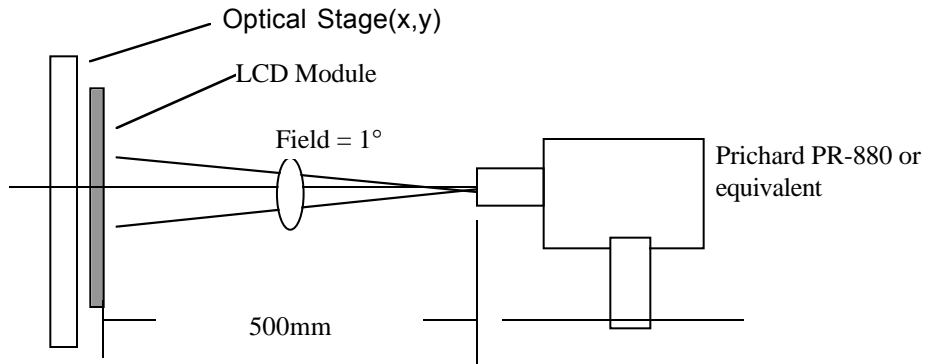

**A-2 Luminance Measurement**

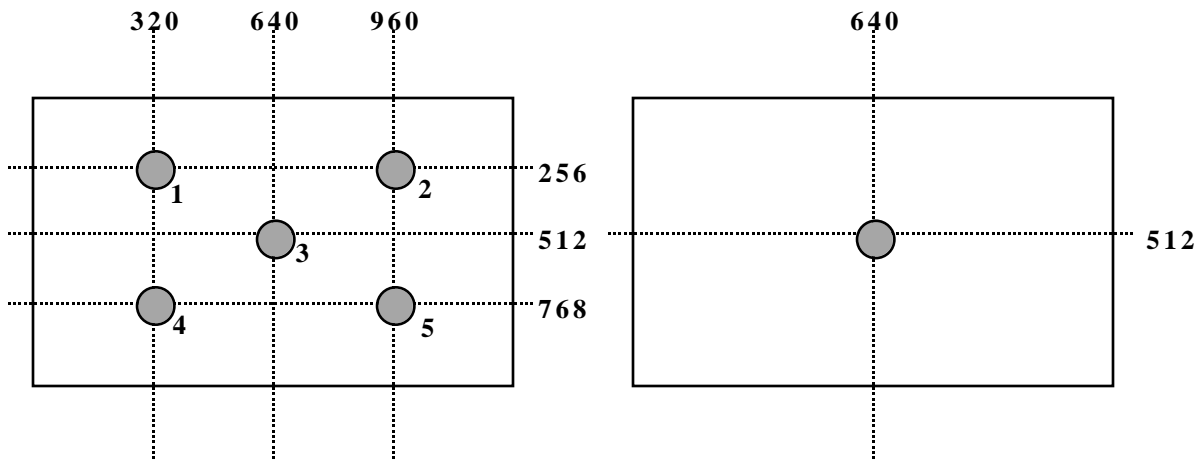

<measuring point for luminance variation>

<measuring point for surface luminance >

**A-3 Response Time**

The response time is defined as the following figure and shall be measured by switching the input signal for „black“ and „white“.

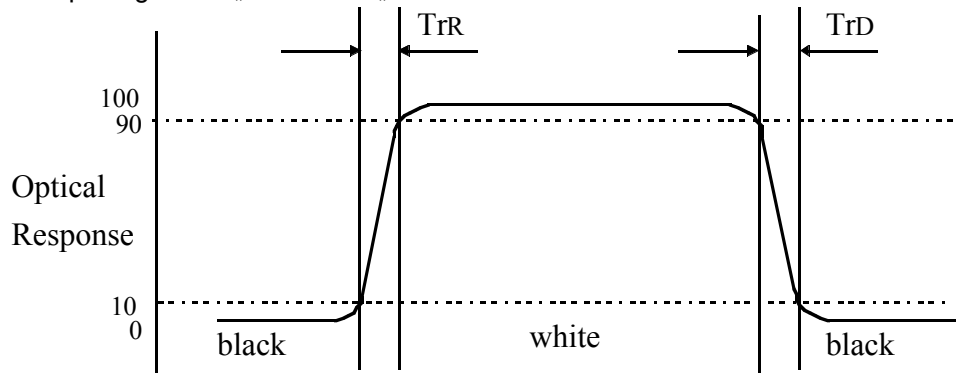



Product Specification

**A-4 Viewing angle**

<Definition of viewing angle range>

