

NEC

TFT COLOR LCD MODULE



Type: NL10276AC30-07
38cm (15 Type), XGA

SPECIFICATIONS

(First Edition)

PRELIMINARY

This document is preliminary. All information in this document is subject to change without prior notice.

NEC Corporation NEC Electron Devices Display Device Operations Unit Color LCD Division 1st Engineering Department		
Approved		Jan. 25, 2001
Checked	/	
Prepared		Jan. 25, 2001

No part of this document may be copied or reproduced in any form or by any means without the prior written consent of NEC Corporation. NEC Corporation assumes no responsibility for any errors, which may appear in this document.

NEC Corporation does not assume any liability for infringement of patents, copyrights or other intellectual property rights of third parties by or arising from use of a device. No license, either express, implied or otherwise, is granted under any patents, copyrights or other intellectual property rights of NEC Corporation or others.

The devices listed in this document are for use of "Standard" applications as specified below, and are not suitable for use of "Special" or "Specific" applications as specified below. NEC disclaims any responsibility or liability of any kind for any failure of equipment, personal injury or damage to property which may arise from the use of NEC devices for such "Special" applications.

The devices listed in this documents should not be used for such "Specific" applications.

Application examples recommended by NEC Corporation.

- Standard: Computers, office equipment, communications equipment, test and measurement equipment, audio and visual equipment, home electronic appliances, machine tools, personal electronic equipment and industrial robots.
- Special: Transportation equipment (automobiles, trains, ships, etc.), traffic control systems, anti-disaster systems, anti-crime systems, safety equipment and medical equipment (not specifically designed for life support).
- Specific: Military systems, aircraft, aerospace equipment, submersible repeaters, nuclear reactor control systems, life support systems or medical equipment for life support, or any other equipment for which specifically high standard of quality or reliability is required.

CONTENTS

1. DESCRIPTION	P.4
2. FEATURES	P.4
3. APPLICATIONS	P.4
4. STRUCTURE AND FUNCTIONS	P.4
5. OUTLINE OF CHARACTERISTICS (at room temperature)	P.5
6. BLOCK DIAGRAM	P.6
7. GENERAL SPECIFICATIONS	P.7
8. ABSOLUTE MAXIMUM RATINGS	P.7
9. ELECTRICAL CHARACTERISTICS	P.7
10. SUPPLY VOLTAGE SEQUENCE	P.9
11. INTERFACE PIN CONNECTIONS	P.11
12. DISPLAY COLORS vs INPUT DATA SIGNALS	P.16
13. INPUT SIGNAL TIMINGS	P.17
14. OPTICAL CHARACTERISTICS	P.21
15. RELIABILITY TEST	P.23
16. ESTIMATED LIFE-TIME OF THE BARE LAMP	P.23
17. GENERAL CAUTIONS	P.24
18. OUTLINE DRAWINGS	P.26

1. DESCRIPTION

NL10276AC30-07 is a TFT (thin film transistor) active matrix color liquid crystal display (LCD) comprising amorphous silicon TFT attached to each signal electrode, a driving circuit and a backlight. NL10276AC30-07 has a built-in backlight with an inverter.

The 38cm(15 Type) diagonal display area contains 1024 × 768 pixels and can display 16,777,216 colors simultaneously.

2. FEATURES

- Parallel 8bit interface (2 port)
- Ultra-wide viewing angle (with lateral electric field)
- Fast response time
- High luminance
- High contrast
- Wide color gamut
- Luminance control
- Small foot print
- Incorporated direct type backlight
- Replaceable backlight unit and inverter

3. APPLICATIONS

PC monitor , FA monitor

4. STRUCTURE AND FUNCTIONS

A color TFT (thin film transistor) LCD module is comprised of a TFT liquid crystal panel structure, LSIs for driving the TFT array, and a backlight assembly. Sandwiching liquid crystal material in the narrow gap between a TFT array glass substrate and a color filter glass substrate creates the TFT panel structure. And the driver LSIs are connected to the panel, the backlight assembly is attached to the backside of the panel. RGB (red, green, blue) data signals from a source system are modulated into a form suitable for active matrix addressing by the onboard signal processor and sent to the driver LSIs which in turn addresses the individual TFT cells.

Acting as an Electro-optical switch, each TFT cell regulates light transmission from the backlight assembly when activated by the data source. By regulating the amount of light passing through the array of red, green, and blue dots, color images are created with clarity.

5. OUTLINE OF CHARACTERISTICS (at room temperature)

Display area	304.128 (H) × 228.096 (V)mm
Drive system	a-Si TFT active matrix
Display colors	16,777,216 colors
Number of pixels	1024 × 768
Pixel arrangement	RGB vertical stripe
Pixel pitch	0.297 (H) × 0.297 (V)mm
Module size	330.0 (H) × 255.4 (V) × 32.0 Max. (D) mm
Weight	1200 g (Typ.)
Contrast ratio	300:1 (Typ.)
Viewing angle (more than the contrast ratio of 10:1)	<ul style="list-style-type: none"> · Horizontal: 85 ° (Typ., left side, right side) · Vertical: 85 ° (Typ., left side, right side)
Designed viewing direction	Optimum grayscale (=2.2): perpendicular
Polarizer Pencil-hardness	2 H (Min., at JIS K5400)
Color gamut	60 % (Typ., At center, To NTSC)
Response time	Ton(10% → 90%) + Toff(90% → 10%) = 30 ms (Typ.)
Luminance	TBD (design target: 400cd/m ² Typ.)
Signal system	Parallel 8bit interface (2port) [RGB 8bit data, CLK, DE]
Supply voltage	5V (Logic, LCD driving) , 12V (Backlight)
Backlight	Direct light type: Eight cold cathode fluorescent lamps and an inverter [Replaceable parts] <ul style="list-style-type: none"> · Backlight unit: TBD · Inverter: TBD
Power consumption	24 W (Typ., Checker flag pattern, at 400 cd/m ² Typ.)

6. BLOCK DIAGRAM

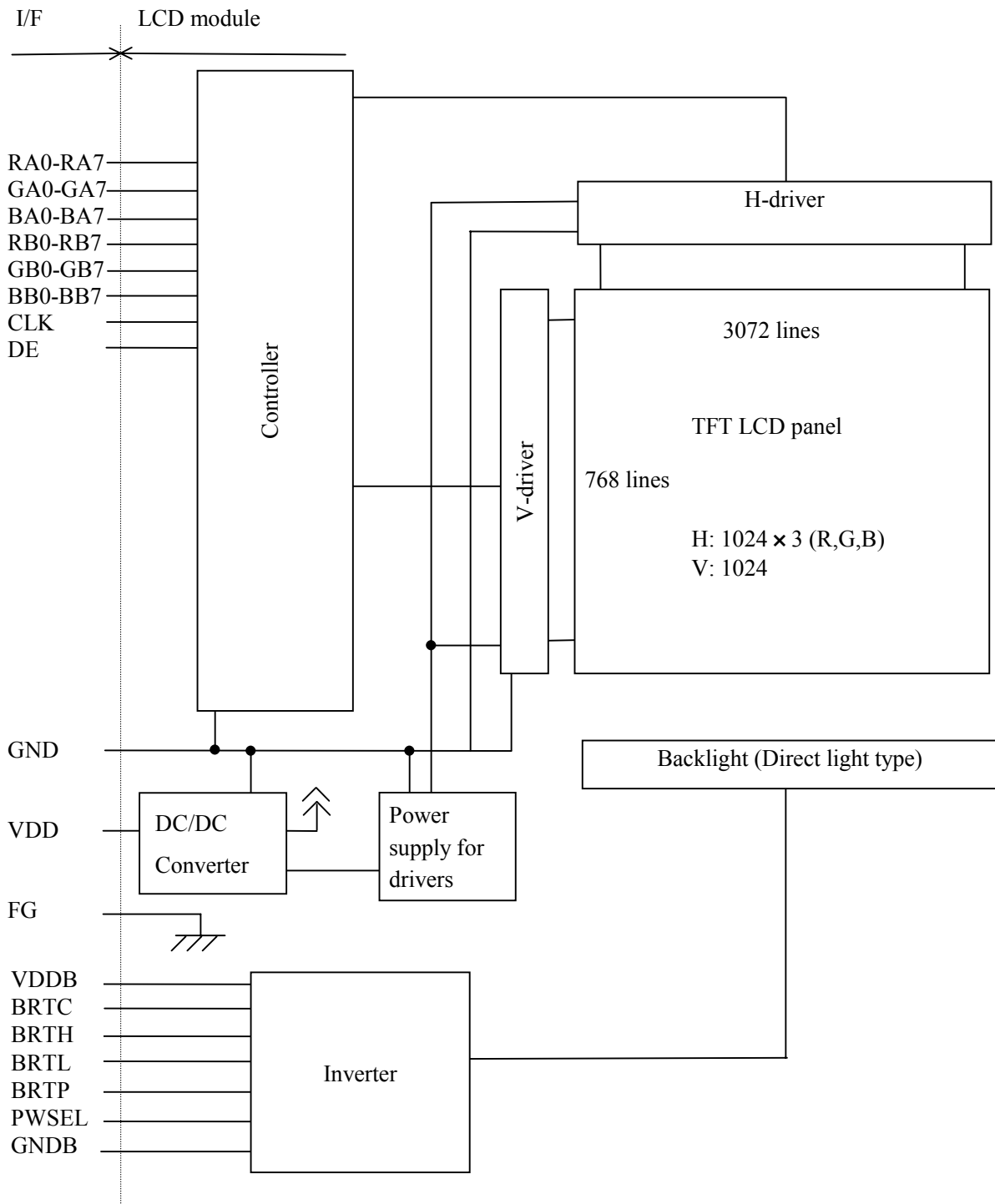

Note1: GND is signal ground for logic and LCD driving. Connections of GND, FG (frame ground) and GNDB are not decided in the LCD module. These grounds should be connected to system ground in customer equipment.

7. GENERAL SPECIFICATIONS

Items	Specifications	Unit
Module size	330.0 ± 1.0 (H) × 255.4 ± 1.0 (V) × 32.0 Max. (D)	mm
Display area	304.128 (H) × 228.096 (V) [Diagonal display area: 38cm (Type 15.0)]	mm
Number of pixels	1024 (H) × 768 (V)	pixel
Dot pitch	0.099 (H) × 0.297 (V)	mm
Pixel pitch	0.297 (H) × 0.297 (V)	mm
Pixel arrangement	RGB (red, green, blue) vertical stripe	—
Display colors	16,777,216 (6bit + FRC)	color
Weight	1200(Typ.), TBD(Max.)	g

8. ABSOLUTE MAXIMUM RATINGS

Parameters	Symbols	Ratings	Unit	Remarks
Supply voltage	VDD	-0.3 to +16	V	Ta = 25
	VDDDB	-0.3 to +16	V	
Logic input voltage (LCD)	Vin1	-0.3 to +4.0	V	Ta = 25 VDDDB=12V
Logic input voltage (backlight-BRTP signal)	Vin2	-0.3 to TBD	V	
Logic input voltage (backlight- BRTC, PWSEL signal)	Vin3	-0.3 to +5.5	V	
Logic input voltage (backlight- BRTL signal)	Vin4	-0.3 to TBD	V	
Storage temperature	Tst	-20 to +60		-
Operating temperature	Top1	0 to +55		Module front surface Note1
	Top2	TBD		Module rear surface Note2
Relative humidity (RH)	Note3	≤ 95	%	Ta ≤ 40
		≤ 85		40 < Ta ≤ 50
		≤ 70		50 < Ta ≤ 55
Absolute humidity	Note3	Absolute humidity shall not exceed Ta=55 , RH =70%.	g/m ³	Ta > 55
Operating altitude		TBD	m	0 ≤ Ta ≤ 55
Storage altitude		TBD	m	-20 ≤ Ta ≤ 60

Note1: Measure at the display area (including self heat)

Note2: Measure at the rear shield (including self heat)

Note3: No condensation

9. ELECTRICAL CHARACTERISTICS

(1) Logic/ LCD driving

Ta = 25

Parameters	Symbols	Min.	Typ.	Max.	Unit	Remarks
Supply voltage	VDD	4.5	5.0	5.5	V	-
Ripple voltage	VRP	-	-	100	mV	for VDD
Logic input "L" voltage	VTL	0	-	0.8	V	-
Logic input "H" voltage	VTH	2.0	-	3.6	V	
Supply current	ICC	-	300 Note1	TBD Note2	mA	VCC=12.0V

Note1: Checker flag pattern (in EIAJ ED-2522)

Note2: Theoretical maximum current pattern

(2) Backlight

Ta = 25

Parameters	Symbols	Min.	Typ.	Max.	Unit	Remarks
Supply voltage	VDDB	11.4	12.0	12.6	V	Backlight power supply
Logic input "L" current ₂	IiL ₂	TBD	-	-	V	for BRTP
Logic input "H" current ₂	IiH ₂	-	-	TBD	V	
Logic input "L" current ₃	IiL ₃	TBD	-	-	V	for BRTC, PWSEL
Logic input "H" current ₃	IiH ₃	-	-	TBD	V	
Logic input "L" current ₄	IiL ₄	TBD	-	-	V	for BRTL
Logic input "H" current ₄	IiH ₄	-	-	TBD	V	
Supply current	IDDB	-	1900	TBD	mA	VDDB=12.0V (at Max. luminance)

Inverter current wave

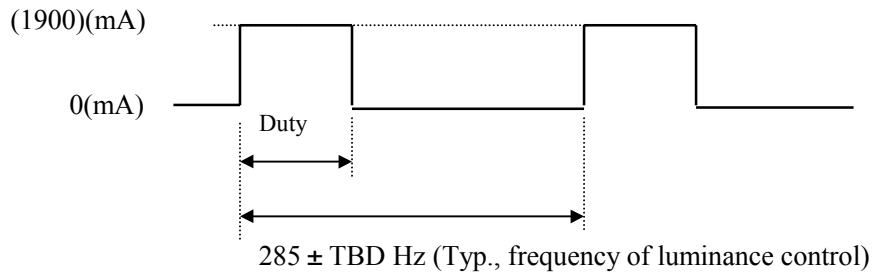

Maximum luminance control : 100% (Duty)

Minimum luminance control : 20% (Duty)

Luminance control frequency : 285 ± TBD Hz (Typ.)

Please see **11.INTERFACE PIN CONNECTIONS** (4) Luminance control.

(3) Fuse

This LCD module uses fuses as follows.

Supply voltage	Part No.	Supplier	Ratings	Remarks
VCC	TBD	TBD	TBD	TBD
VDDB	TBD	TBD	TBD	TBD

Remark: Before the power is designed, fuses should be considered. The power capacity should be used more than 2.0 times of fuses rating. When the power capacity is less than 2.0 times of fuses rating, the module must be evaluated enough from safety point of view.

10. SUPPLY VOLTAGE SEQUENCE

(1) Supply voltage sequence and backlight control sequence

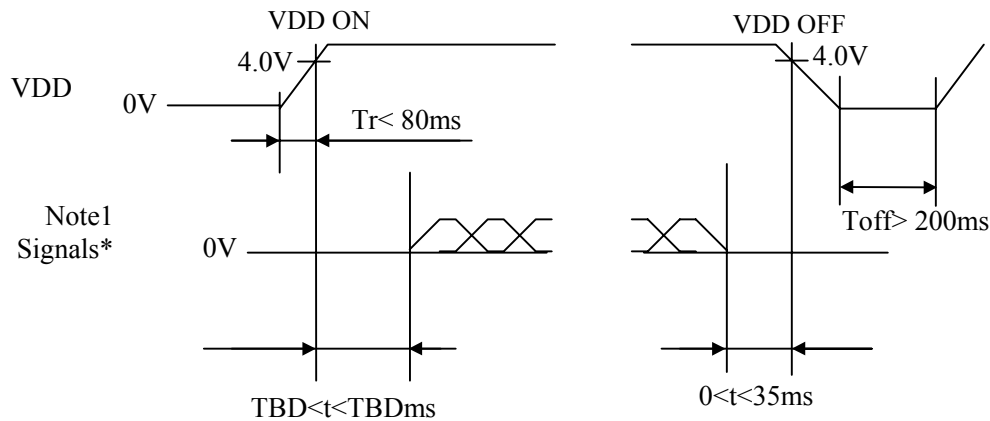

* Signals: DE, CLK, RA0 to RB7, GA0 to GB7, BA0 to BB7

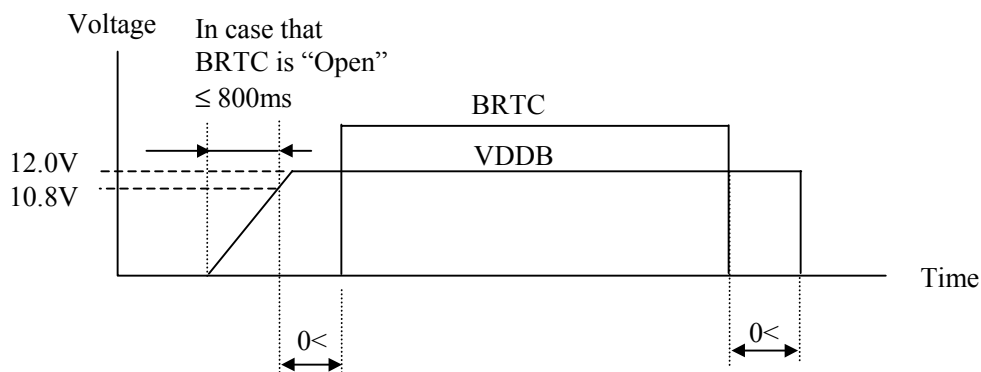

Note1: The values of signals are in terminal of resistor 100 ohm.

Remark1: Logic signals (synchronous signals and control signals) should be "0" voltage (V), when VDD is not input. If input voltage to signal lines is higher than 0.3 V, the internal circuit will be damaged.

Remark2: When the power supply voltage (VDD) fluctuates less than 4V, the LCD module may not be worked by the protection circuit.

Remark3: Turn on the backlight should be controlled while logic signals are supplied. The backlight power supply (VDDDB) is not related to the power supply sequence. However, unstable data will be displayed when the backlight power is turned ON with no logic signals.

Remark4: 12V for backlight should be started up within 800ms, otherwise, the protection circuit makes the backlight turn off.

Remark5: The backlight is turned off with safety circuit, when "L" period of BRTP signal is input more than 50 ms.

Remark6: Do not input "H" PWSEL, when VDDDB is 0V or BRTC is "L".

(2)Ripple of supply voltage

Supply voltage	VDD (for logic and LCD driver: 5V)	VDDDB (for backlight: 12V)
Acceptable range	$\leq 100 \text{ m V p-p}$	$\leq 200 \text{ m V p-p}$

Note1: The acceptable range of ripple voltage includes spike noise.

Example of the power supply connection

a) Separate the power supplies

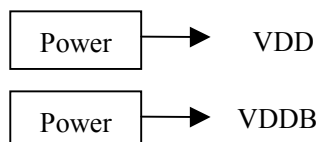

b) Put in the filters

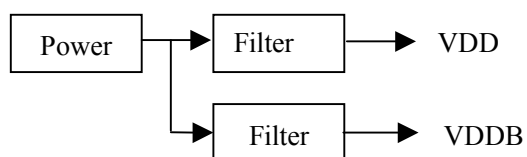

11. INTERFACE PIN CONNECTIONS

(1) Interface connectors for signals and power

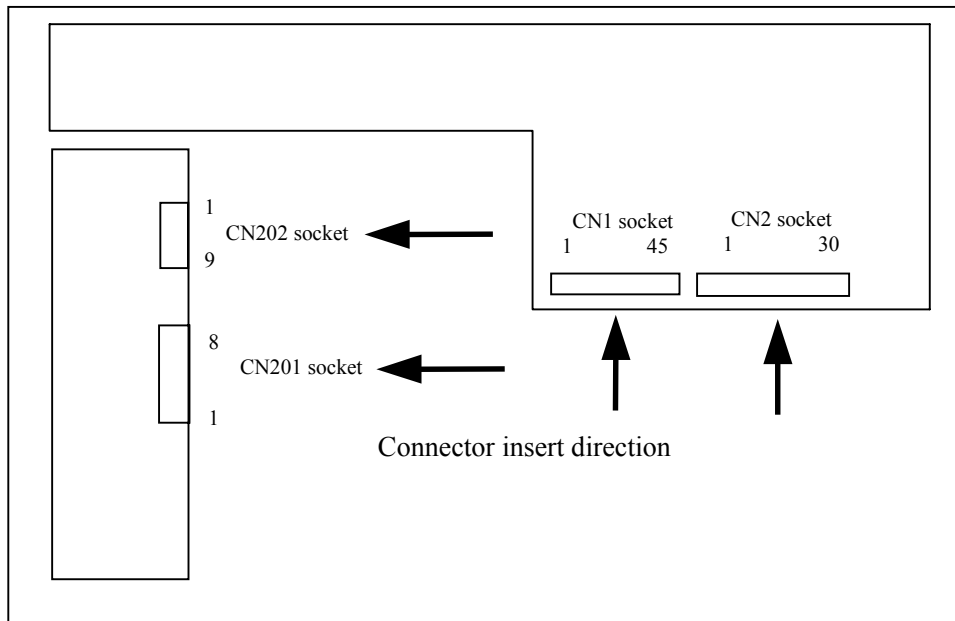

(2) Interface connector for signals and power

CN1 socket: IL-FHR-F45S-HF(JAE)

Adaptable plug: TBD

Pin No.	Symbols	Signals type	Functions
1	GND	Ground	Connect to system ground.
2	CLK	Dot clock	Dot clock input
3	GND	Ground	Connect to system ground.
4	DE	Data enable	Data enable input
5	GND	Ground	Connect to system ground.
6	N.C.	Non-connection	Keep the terminal open
7	GND	Ground	Connect to system ground.
8	N.C.	Non-connection	Keep the terminal open
9	GND	Ground	Connect to system ground.
10	N.C.	Non-connection	Keep the terminal open
11	GND	Ground	Connect to system ground.
12	BA7	Odd pixel data B	Odd pixel data B input BA7: Most significant bit
13	BA6		
14	BA5		
15	BA4		
16	GND	Ground	Connect to system ground.
17	BA3	Odd pixel data B	Odd pixel data B input BA0: Least significant bit
18	BA2		
19	BA1		
20	BA0		

CN1 socket

Pin No.	Symbols	Signals type	Functions
21	GND	Ground	Connect to system ground.
22	GA7	Odd pixel data G	Odd pixel data G input GA7: Most significant bit
23	GA6		
24	GA5		
25	GA4		
26	GND	Ground	Connect to system ground.
27	GA3	Odd pixel data G	Odd pixel data G input GA0: Least significant bit
28	GA2		
29	GA1		
30	GA0		
31	GND	Ground	Connect to system ground.
32	RA7	Odd pixel data R	Odd pixel data R input RA7: Most significant bit
33	RA6		
34	RA5		
35	RA4		
36	GND	Ground	Connect to system ground.
37	RA3	Odd pixel data R	Odd pixel data R input RA0: Least significant bit
38	RA2		
39	RA1		
40	RA0		
41	VDD	+5V Power Supply	+5V±TBD%
42	VDD		
43	VDD		
44	VDD		
45	N.C.	Non-connection	Keep the terminal open

CN1 socket: Figure from socket view

1	2	•	•	•	•	•	44	45
---	---	---	---	---	---	---	----	----

CN2 socket: IL-FHR-F30S-HF(JAE)

Adaptable plug: TBD

Pin No.	Symbols	Signals type	Functions
1	GND	Ground	Connect to system ground.
2	BB7	Even pixel data B	Even pixel data B input BB7: Most significant bit
3	BB6		
4	BB5		
5	BB4		
6	GND	Ground	Connect to system ground.
7	BB3	Even pixel data B	Even pixel data B input BB0: Least significant bit
8	BB2		
9	BB1		
10	BB0		
11	GND	Ground	Connect to system ground.
12	GB7	Even pixel data G	Even pixel data G input GB7: Most significant bit
13	GB6		
14	GB5		
15	GB4		

CN2 socket

Pin No.	Symbols	Signals type	Functions
16	GND	Ground	Connect to system ground.
17	GB3	Even pixel data G	Even pixel data G input GB0: Least significant bit
18	GB2		
19	GB1		
20	GB0		
21	GND	Ground	Connect to system ground.
22	RB7	Even pixel data R	Even pixel data R input RB7: Most significant bit
23	RB6		
24	RB5		
25	RB4		
26	GND	Ground	Connect to system ground.
27	RB3	Even pixel data R	Even pixel data R input RB0: Least significant bit
28	RB2		
29	RB1		
30	RB0		

CN2 socket: Figure from socket view

1	2	29	30
---	---	-------	----	----

(3) Connector for backlight unit

CN201 socket: DF3-8P-2H (HIROSE ELECRIC Co., Ltd.)

Adaptable plug: TBD

Pin No.	Symbols	Functions
1	GNDB	Ground for backlight (Connect to system ground.)
2	GNDB	
3	GNDB	
4	GNDB	
5	VDDDB	Power supply for backlight (+12V ± 5%)
6	VDDDB	
7	VDDDB	
8	VDDDB	

CN201 socket: Figure from socket view

1	2	7	8
---	---	-------	---	---

CN202 socket: IL-Z-9PL1-SMTY(JAE)

Adaptable plug: TBD

Pin No.	Symbols	Functions
1	GNDB	Ground for backlight (Connect to system ground.)
2	GNDB	
3	N.C.	Keep the terminal open
4	BRTC	Backlight ON/OFF control signal “H” or “Open” : Backlight ON “L” : Backlight OFF
5	BRTH	Luminance control signal, Please see (4) Luminance control.
6	BRTL	
7	BRTP	
8	GNDB	Ground for backlight
9	PWSEL	Select signal of PWM luminance control function Please see (4) Luminance control.

CN202 socket: Figure from socket view

9	8	2	1
---	---	-------	---	---

Remark1: Do not keep pins free (except N.C. Pin) to avoid noise issue.

Remark2: GND and GNDB should be connected to system ground in customer equipment.

(4) Luminance control

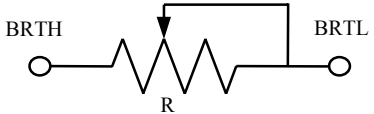
Form	PWM	Voltage	Variable resistor
How to adjust	PWSEL="L"	PWSEL="H" or "Open" and BRTP="OPEN"	
	See OUTSIDE CONTROL FOR LUMINANCE	BRTH should be fixed to 0V to control luminance by voltage. The range of input voltage between BRTL and GNDB is as follows. Maximum luminance: 1V(TBD%) Minimum luminance: 0V(TBD%)	The variable resistor for luminance control should be 10 kΩ type, and zero point of the resistor corresponds to the minimum of luminance.  Maximum luminance: R=10 kΩ(TBD%) Minimum luminance : R= 0 Ω(TBD%) Mating variable resistor: 10 kΩ B curve, 1/10W

Remark: The display may be disturbed depend on input signal timing in this luminance control method. In this case, adopt outside control for luminance to avoid interference of the input signal timing and backlight driving timing.

[OUTSIDE CONTROL FOR LUMINANCE]

Outside control is valid, when PWSEL="L" and input signal for BRTP. Luminance can be controlled by the duty value of input signal for BRTP.

Duty=100%: luminance is maximum.

Duty=20%: luminance is minimum.

BRTP must not fix on "L" in the condition of PWSEL= "L" and BRTP = "H" or "Open". Otherwise, the inverter stops. In this case, even if BRTP pulse is input again, the backlight will not turn on. Please input power supply to the inverter again.

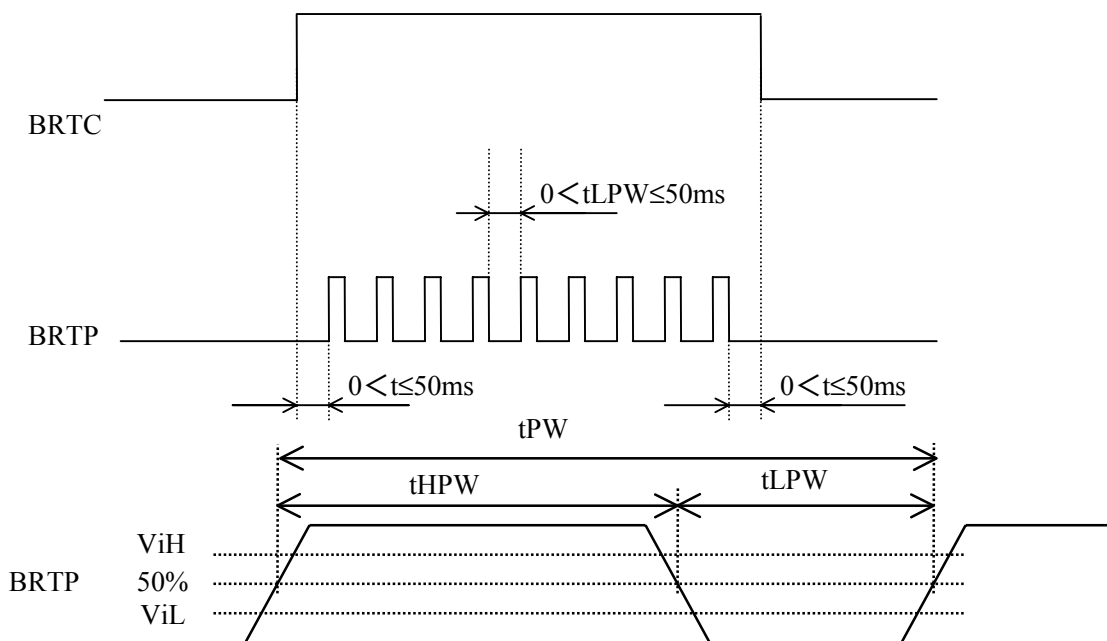

Parameters	Symbols	Min.	Typ.	Max.	Units	Remarks
Frequency	1/tPW	185	-	325	Hz	Note1
“L” period	tLPW	-	-	50	ms	Note2
Pulse-width	tHPW/tPW	20	-	100	%	Duty=100%: Luminance is maximum. Duty=20%: Luminance is minimum.
Luminance	Lu	-	30-100	-	%	-
Input voltage	ViL	0	-	0.8	V	-
	ViH	2.0	-	5.0	V	-

Note1: Regarding set up for frequency, refer to the below method.

Set up frequency = Vsync frequency \times (n+0.25) or (n+0.75)

Adopt the frequency evaluating the display quality, because the display will be disturbed depend on frequency.

Note2: The backlight is turned off with safety circuit, when “L” period of BRTP signal is input more than 50 ms.

12. DISPLAY COLORS vs INPUT DATA SIGNALS

Display colors		Data signal (0: Low level, 1: High level)																							
		RA7 RA6 RA5 RA4 RA3 RA2 RA1 RA0								GA7 GA6 GA5 GA4 GA3 GA2 GA1 GA0								BA7 BA6 BA5 BA4 BA3 BA2 BA1 BA0							
		RB7 RB6 RB5 RB4 RB3 RB2 RB1 RB0	GB7 GB6 GB5 GB4 GB3 GB2 GB1 GB0	BB7 BB6 BB5 BB4 BB3 BB2 BB1 BB0																					
Basic colors	Black	0	0	0	0	0	0	0	0	0	0	0	0	0	0	0	0	0	0	0	0	0	0	0	0
	Blue	0	0	0	0	0	0	0	0	0	0	0	0	0	0	0	0	1	1	1	1	1	1	1	1
	Red	1	1	1	1	1	1	1	1	0	0	0	0	0	0	0	0	0	0	0	0	0	0	0	0
	Magenta	1	1	1	1	1	1	1	1	0	0	0	0	0	0	0	0	1	1	1	1	1	1	1	1
	Green	0	0	0	0	0	0	0	0	1	1	1	1	1	1	1	1	0	0	0	0	0	0	0	0
	Cyan	0	0	0	0	0	0	0	0	1	1	1	1	1	1	1	1	1	1	1	1	1	1	1	1
	Yellow	1	1	1	1	1	1	1	1	1	1	1	1	1	1	1	1	0	0	0	0	0	0	0	0
	White	1	1	1	1	1	1	1	1	1	1	1	1	1	1	1	1	1	1	1	1	1	1	1	1
Red grayscale	Black	0	0	0	0	0	0	0	0	0	0	0	0	0	0	0	0	0	0	0	0	0	0	0	0
	dark	0	0	0	0	0	0	0	1	0	0	0	0	0	0	0	0	0	0	0	0	0	0	0	0
						:								:								:			
	bright	1	1	1	1	1	1	0	1	0	0	0	0	0	0	0	0	0	0	0	0	0	0	0	0
		1	1	1	1	1	1	1	0	0	0	0	0	0	0	0	0	0	0	0	0	0	0	0	0
	Red	1	1	1	1	1	1	1	1	0	0	0	0	0	0	0	0	0	0	0	0	0	0	0	0
Green grayscale	Black	0	0	0	0	0	0	0	0	0	0	0	0	0	0	0	0	0	0	0	0	0	0	0	0
	dark	0	0	0	0	0	0	0	0	0	0	0	0	0	0	0	1	0	0	0	0	0	0	0	0
						:								:								:			
	bright	0	0	0	0	0	0	0	0	1	1	1	1	1	1	0	1	0	0	0	0	0	0	0	0
		0	0	0	0	0	0	0	0	1	1	1	1	1	1	1	0	0	0	0	0	0	0	0	0
	Green	0	0	0	0	0	0	0	0	1	1	1	1	1	1	1	1	0	0	0	0	0	0	0	0
Blue grayscale	Black	0	0	0	0	0	0	0	0	0	0	0	0	0	0	0	0	0	0	0	0	0	0	0	0
	dark	0	0	0	0	0	0	0	0	0	0	0	0	0	0	0	0	0	0	0	0	0	0	0	1
						:								:								:			
	bright	0	0	0	0	0	0	0	0	0	0	0	0	0	0	0	0	1	1	1	1	1	1	0	1
		0	0	0	0	0	0	0	0	0	0	0	0	0	0	0	0	1	1	1	1	1	1	1	0
	Blue	0	0	0	0	0	0	0	0	0	0	0	0	0	0	0	0	1	1	1	1	1	1	1	1

Note1: Colors are developed in combination with 8-bit signals (256 steps in grayscale) of each primary red, green, and blue color. This process can result in up to 16,777,216 (256 × 256 × 256) colors.

13. INPUT SIGNAL TIMINGS

(1) Input signal specifications for LCD controller (2 port input)

	Parameters		Symbols	Min.	Typ.	Max.	Units	Remarks
CLK	Frequency	Vf=75Hz	1/ tc	TBD	39.375	TBD	MHz	-
		Vf=60Hz		-	25.397	-	ns	
	Duty		tcl / tc	0.4	0.5	0.6	-	
Hsync	Period	Vf=75Hz	th	(12.3)	16.660	-	μ s	Typ.=60.023kHz
		Vf=60Hz		(550)	656	(1000)	CLK	
	Display period		thd	-	512	-	CLK	-
	Front-porch	Vf=75Hz	thf	-	8	-	CLK	-
		Vf=60Hz		-	12	-		
	Pulse width	Vf=75Hz	thp *	-	48	-	CLK	-
		Vf=60Hz		-	68	-		
	Back-porch	Vf=75Hz	thb *	-	88	-	CLK	-
Vf=60Hz		-		80	-			
* thp + thb				(38)	-	-	CLK	-
Vsync	Period	Vf=75Hz	tv	-	13.328	TBD	ms	Typ=75.029Hz
		Vf=60Hz		(771)	800	-	H	
	Display period		tvd	-	768	-	H	-
	Front-porch	Vf=75Hz	tvf *	-	1	-	H	-
		Vf=60Hz		-	3	-		
	Pulse width		tvp *	-	3	-	H	-
				-	6	-		
	Back-porch		tvb *	-	28	-	H	-
				-	29	-		
	* tvp + tvb + tvf				(3)	-	-	H
Vsync-Hsync timing			tvhs	1	-	-	CLK	-
Hsync-Vsync timing			tvhh	1	-	-	CLK	-
DATA (RA0-RB7) (GA0-GB7) (BA0-BB7)	DATA-CLK (Set up)		tds	(2)	-	-	ns	-
	CLK-DATA (Hold)		tdh	(2)	-	-	ns	-
DE	DE-CLK timing		tes	(2)	-	-	ns	-
	CLK-DE timing		the	(2)	-	-	ns	-

(2) Input signals timing chart for LCD

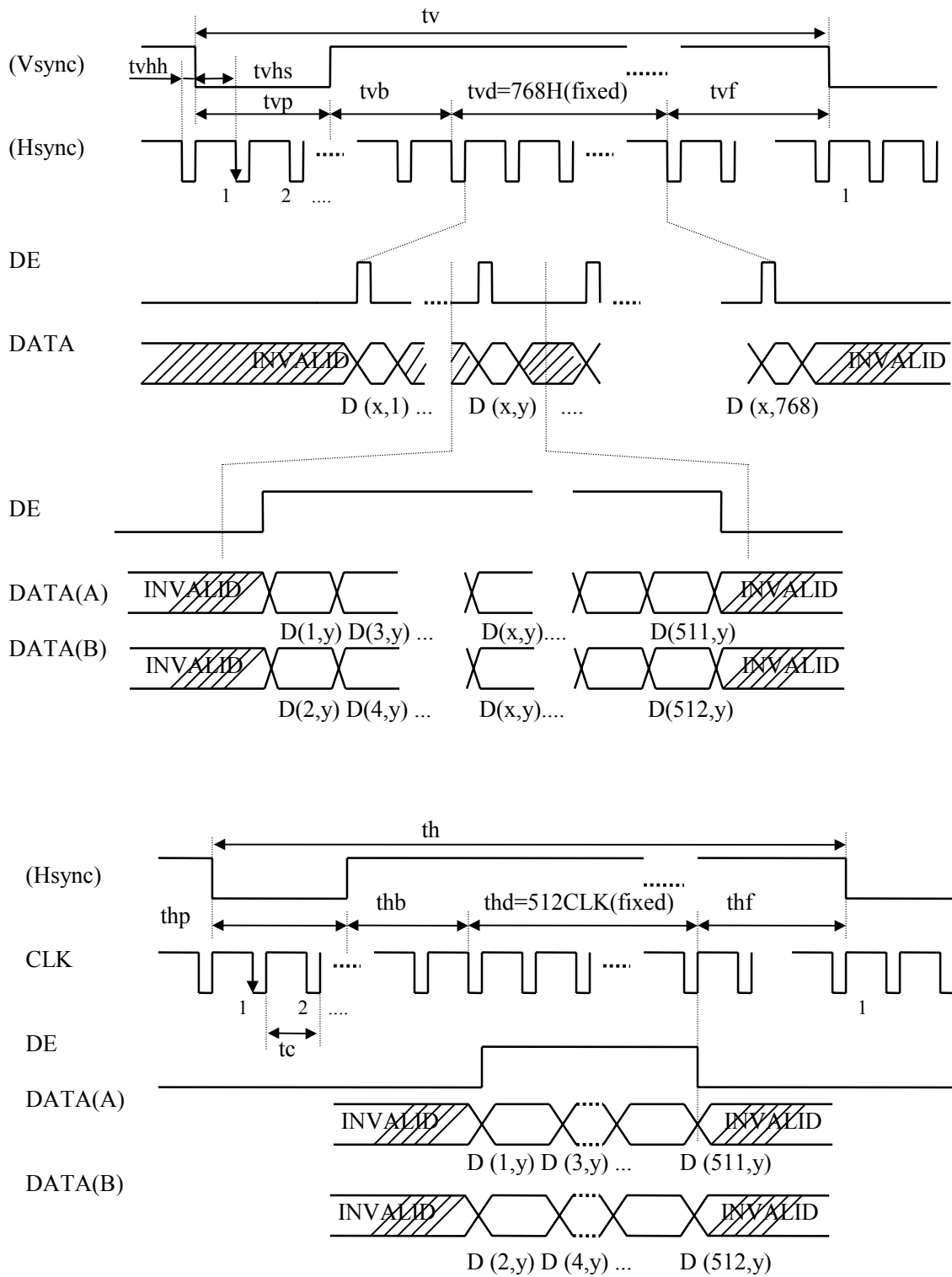

DATA(A): RA0-RA7, GA0-GA7, BA0-BA7
 DATA(B): RB0-RB7, GB0-GB7, BB0-BB7

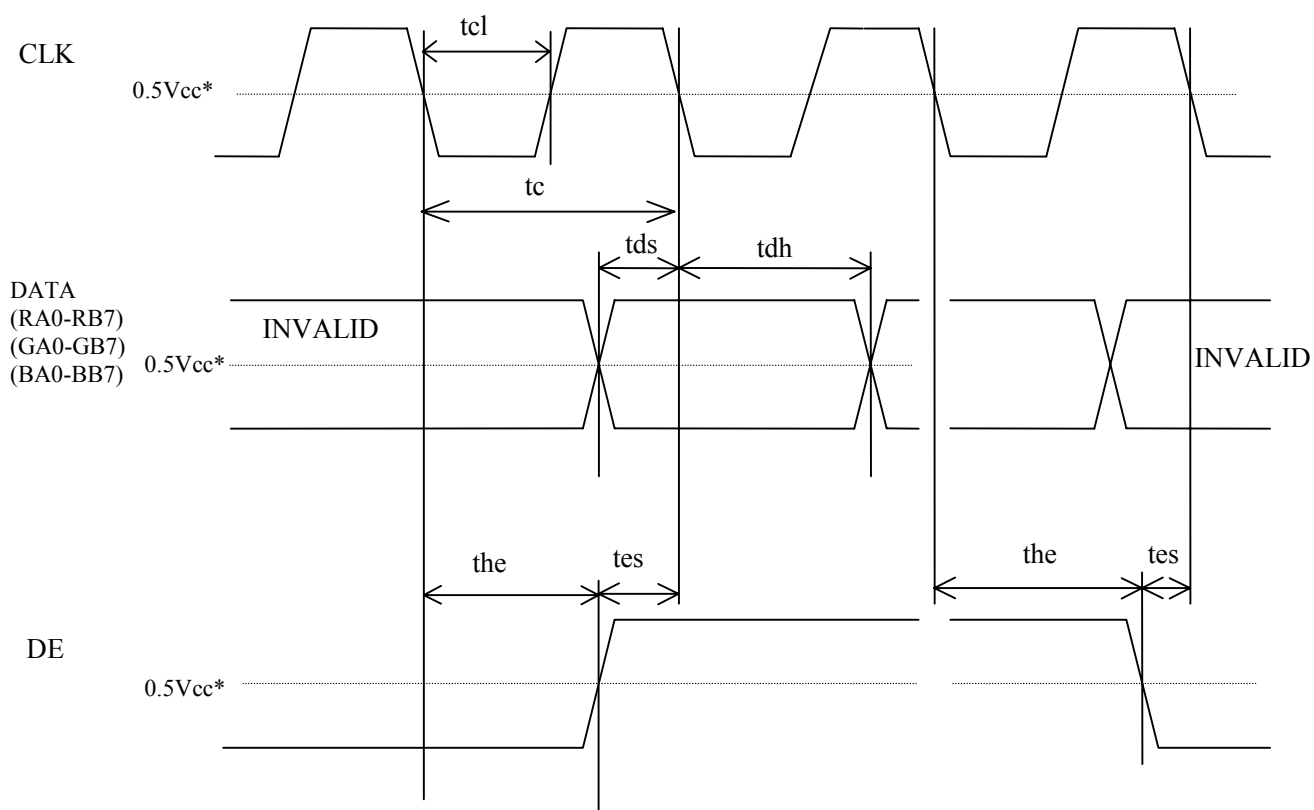

* $V_{cc}=3.3V$ Typ.

(3) Display positions of input data

Odd Pixel: RA= R DATA Even Pixel : RB=R DATA
 Odd Pixel: GA= G DATA Even Pixel : GB=G DATA
 Odd Pixel: BA= B DATA Even Pixel : BB=B DATA

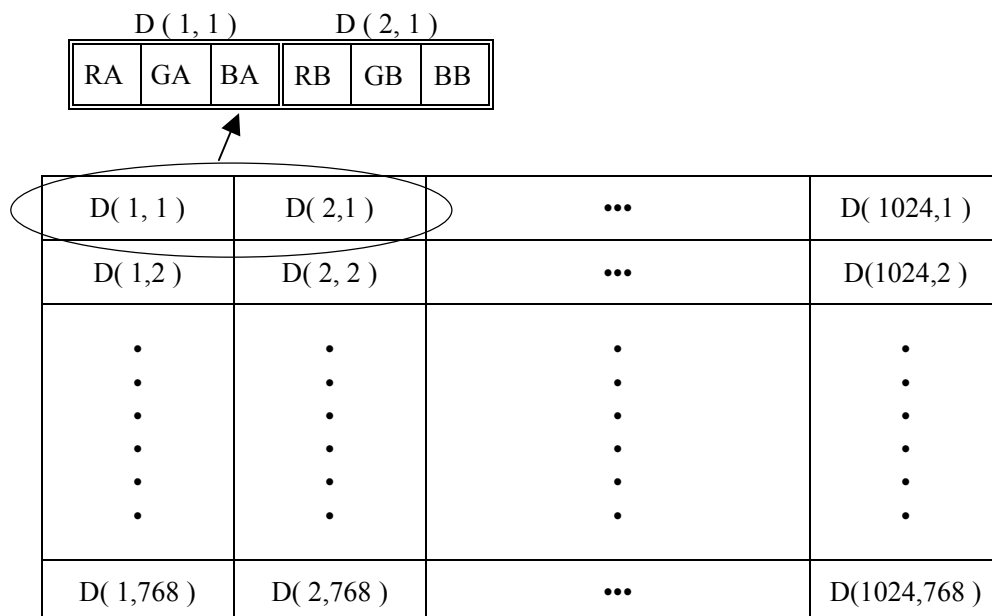

14. OPTICAL CHARACTERISTICS

(Ta= 25 , VDD= 5V, VDDDB=12V, Note1)

Parameters	Symbols	Conditions	Min.	Typ.	Max.	Units	Remarks
Contrast ratio	CR	Note 3	TBD	(300)	-	-	Note2
Luminance	Lumax	Note 3	TBD	TBD (design target: 400cd/m ² Typ.)	-	cd/m ²	-
Luminance uniformity	-	Max. / Min.	-	(1.1)	1.3	-	Note3,6
Chromaticity Coordinates	W	White (x, y)	-	(0.300, 0.315)	-	-	Note3
	R	Red (x, y)	-	TBD	-	-	
	G	Green (x, y)	-	TBD	-	-	
	B	Blue (x, y)	-	TBD	-	-	

Reference data

(Ta= 25 , VDD= 5V, VDDDB=12V, Note1)

Parameters	Symbols	Conditions	Min.	Typ.	Max.	Units	Remarks	
Color gamut	C	To NTSC	50	60	-	%	Note3	
Viewing Angle Range (CR>10)	Horizontal	x+	CR>10, y = ±0 °	70	85	-	deg.	Note4
		x-		70	85	-	deg.	
	Vertical	y+	CR>10, x = ±0 °	70	85	-	deg.	
		y-		70	85	-	deg.	
Viewing Angle Range (CR>5)	Horizontal	x+	CR>5, y = ±0 °	-	85	-	deg.	Note4
		x-		-	85	-	deg.	
	Vertical	y+	CR>5, x = ±0 °	-	85	-	deg.	
		y-		-	85	-	deg.	
Response time (Module front surface temperature = TBD)	Ton	White to black	90% 10%	-	TBD	TBD	ms	Note3,5
	Toff	Black to white	10% 90%	-	TBD	TBD		
	Ton(10% 90%) + Toff(90% 10%)		-	(30)	-			
Luminance control range	-	Maximum luminance:100%	-	30-100	-	%	-	

Note1: Optical characteristics are measured after 20 minutes from the module works. Typical value is measured after luminance saturation. The luminance is measured in dark room.

Input signal timing: XGA-60Hz mode

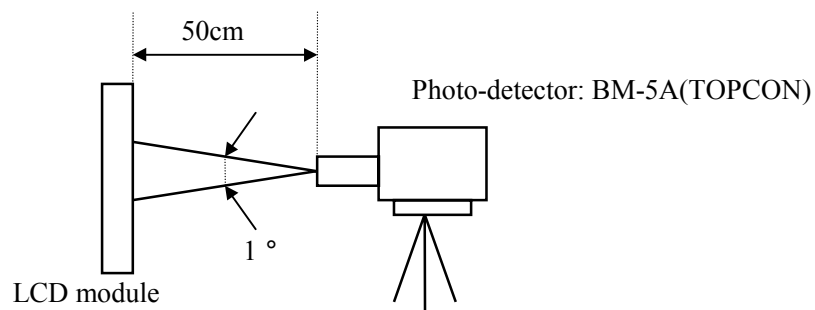

Note2: The contrast ratio is calculated by using the following formula.

$$\text{Contrast ratio (CR)} = \frac{\text{Luminance with all pixels in white}}{\text{Luminance with all pixels in black}}$$

Note3: Viewing angle is $x = \pm 0^\circ$, $y = \pm 0^\circ$ and at center.

Note4: Definitions of viewing angle are as follows

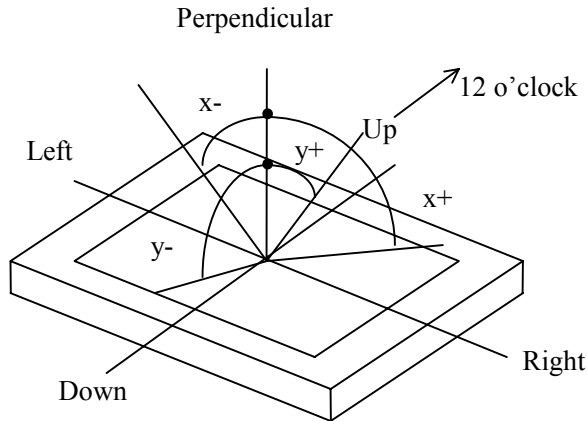

Note5: Definitions of response time are as follows.

Photo-detector output signal is measured when the luminance changes "white" to "black" or "black" to "white". Response time is the time between 10% and 90% of the photo-detector output amplitude.

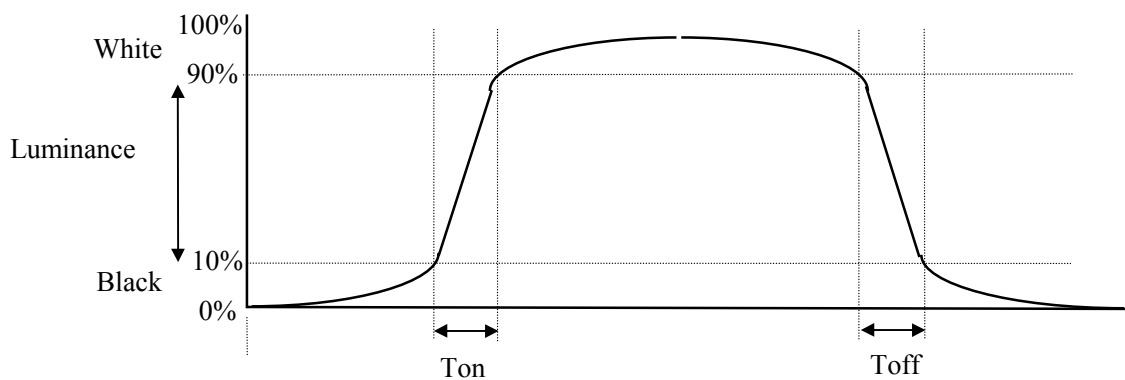

Note6: Luminance uniformity is calculated by using the following formula.

$$\text{Luminance uniformity} = \frac{\text{Maximum luminance}}{\text{Minimum luminance}}$$

The luminance is measured at near the five points shown below.

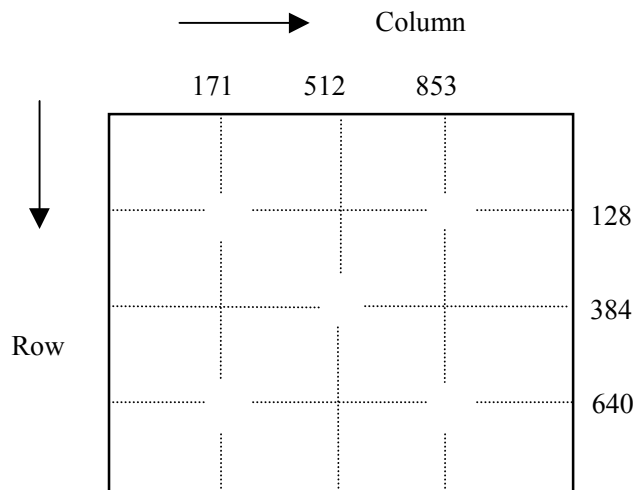

15. RELIABILITY TEST

Test items	Test conditions	Judgment
High temperature/humidity operation	60 ± 2 , RH=60% 240 hours, Display data is black.	*1
Heat cycle (operation)	0 ± 3 ∙∙∙ 1 hour 55 ± 3 ∙∙∙ 1 hour 50 cycles , 4 hours/cycle Display data is black.	*1
Thermal shock (non-operation)	-20 ± 3 ∙∙∙ 30 minutes 60 ± 3 ∙∙∙ 30 minutes 100 cycles Temperature transition time is within 5 minutes.	*1
Vibration (non-operation)	5-100Hz, 11.76m/s ² , 1 minute/cycle, X,Y,Z direction 50 times each direction	*1, *2
Mechanical shock (non-operation)	294m/s ² , 11ms X,Y,Z direction 3 times each direction	*1, *2
ESD (operation)	150pF, 150 , ± 10kV 9 places on a panel *3 10 times each place at one-second intervals	*1
Dust (operation)	15 kinds of dust (JIS-Z 8901) Hourly 15 seconds stir, 8 times repeat	*1

*1: Display function is checked by the same condition as LCD module out-going inspection.

*2: Physical damage

*3: Discharge points are shown in the figure.

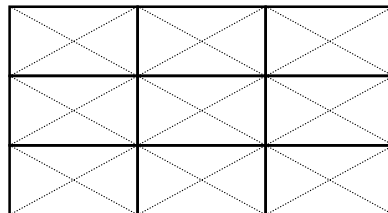
**16. ESTIMATED LIFE-TIME OF THE BARE LAMP**

	Bare lamp
Conditions	Luminance Maximum Room temp. (25 ± 2), Continuous operation Note3
Estimated value (MTTF)	50,000h Note 1,2
Criteria	Half value luminance (compared with initial value.)

Note1: The life-time is **estimated value (reference)**.

Note2: **This estimated value is based on the test results with a bare lamp operation.** The MTTF for the module may be different from these values, because of the influence of ambient and clamshell conditions.

Note3: The life-time becomes short if the module is operated under the low and high temperature environment.

17. GENERAL CAUTIONS

Because the following statements are very important, please be sure you understand their contents completely.



CAUTION

This figure is a warning that you will get hurt and/or the module will be damaged if you make a mistake in operation.



This figure is a warning that you will get an electric shock if you make a mistake in operation.



This figure is a warning that you will get hurt if you make a mistake in operation.



CAUTIONS



Do not touch an inverter on which there is a caution label is stuck while the LCD module is in operation, because of dangerous high voltage.

(1) Caution when taking out the module

Pick up the pouch only, when removing the module from a carrier box.

(2) Cautions for handling the module

As the electrostatic discharges may break the LCD module, handle the LCD module with care against electrostatic discharges. Peel protection sheet out from the LCD panel surface as slowly as possible.



As the LCD panel and backlight element are made from fragile glass material, impulse and pressure to the LCD module should be avoided.

As the surface of polarizer is very soft and easily scratched, use a soft dry cloth without chemicals for cleaning.

Do not pull the interface connectors in or out while the LCD module is operating.

Put the module display side down on a flat horizontal plane.

Handle connectors and cables with care.

When the module is operating, do not lose CLK, Hsync, or Vsync signal. If any one or more of these signals is lost, the LCD panel would be damaged.

The torque for mounting screws should never exceed 0.39N·m.

Don't push or rub the surface of LCD module please.

If you do, the scratches or the marks like rubbing marks may be left on the surface of the module.

Do not give the stress too much on interface connectors. The module may become function deficiency by a contact defective and damages. Pay attention to handling at the time of matching connector connection and in the connection condition.

Do not put front side (display surface side) of the module on a desk or a table for a long time, because the display may become un-uniformity.

(3) Cautions regarding atmosphere

Dew-drop atmosphere must be avoided.

Do not store and/or operate the LCD module in a high-temperature and/or high-humidity atmosphere. Storage in an anti-static pouch and under the room temperature atmosphere is recommended.

This module uses cold cathode fluorescent lamps. Therefore the lifetime of lamps is shortened if the module is operated under the low temperature environment.

Do not operate the LCD module in high magnetic field.

(4) Cautions about the module characteristics

Do not apply any fixed pattern data for a long time to the LCD module. It may cause image sticking. Use screen savers if the display pattern is fixed.

This module has the lens sheet which may cause the variation of the color hue in the different viewing angles. The ununiformity may appear on the screen under the high temperature operation.

The light vertical stripe may be observed depending on the display pattern. This is not defects or malfunctions.

The noise from the inverter circuit may be observed in the luminance control mode. This is not defects or malfunctions.

(5) Other cautions

Do not disassemble and/or reassemble the LCD module.

Do not readjust variable resistors nor switches in the module.

When returning the module for repair, etc., please pack the module properly to avoid any damages. NEC recommends using original shipping packages.

The liquid crystal display has the following specific characteristics. These are not defects or malfunctions.

The optical characteristics of this module may be affected by the ambient temperature.

This module has cold cathode tube for backlight. Optical characteristics, like luminance or uniformity, will be changed by the progress in time.

Uneven brightness and/or small spots may be observed depending on different display patterns.

18.OUTLINE DRAWINGS(Unit: mm)

