

Tentative

First Edition
Sep 19, 2001
Final Revision



LCD Module Technical Specification

T-51639D084U-FW-A-AA

Checked by (Quality Assurance Div.)

Checked by (Design Engineering Div.)

Prepared by (Production Div.)

Table of Contents

1. Overview.....	2
2. Absolute Maximum Ratings.....	3
3. Electrical Characteristics.....	3
4. Interface Pin Connection.....	5
5. Interface Timing.....	6
6. Block Diagram.....	10
7. Mechanical Specification.....	11
8. Optical Characteristics.....	13
9. Reliability Test Condition.....	15
10. Inverted Scan Capability.....	16
11. Handling Precautions for TFT-LCD Module.....	17

Revision History

Rev.	Date	Page	Comment

1. OVERVIEW

T-51639D084U-FW-A-AA is 8.4" color TFT-LCD (Thin Film Transistor Liquid Crystal Display) module composed of LCD panel, driver ICs, control circuit, and backlight unit.

By applying 6 bit digital data, 1024 × 768, 262 K-color images are displayed on the 8.4" diagonal screen. Input power voltage is single 3.3V for LCD driving.

Inverter for backlight is not included in this module. General specifications are summarized in the following table:

ITEM	SPECIFICATION
Display Area (mm)	171.264(H) × 128.448 (V) (8.43-inch diagonal)
Number of Dots	1024 × 3 (H) × 768 (V)
Pixel Pitch (mm)	0.16725 (H) × 0.16725 (V)
Color Pixel Arrangement	RGB vertical stripe
Display Mode	normally white
Number of Color	262 K
Optimum Viewing Angle(Contrast ratio)	12 o'clock
Brightness (cd/m ²)	300
Module Size (mm)	205.0 (W) × 152.4 (H) × 11.3 (D)
Module Mass (g)	430 (Typ)
Backlight Unit	CCFL, 2-tubes, replaceable
Surface Treatment	Anti-glare and hard-coating 3H

Sign "()" represents preliminary value. Characteristic value without any note is typical value.

The LCD product described in this specification is designed and manufactured for the standard use in OA equipment and consumer products, such as computers, communication equipment, industrial robots, AV equipment and so on.

Do not use the LCD product for the equipment that require the extreme high level of reliability, such as aerospace applications, submarine cables, nuclear power control systems and medical or other equipment for life support.

ADI assumes no responsibility for any damage resulting from the use of the LCD product in disregard of the conditions and handling precautions in this specification.

If customers intend to use the LCD product for the above items or other no standard items, please contact our sales persons in advance.

2. ABSOLUTE MAXIMUM RATINGS

ITEM	SYMBOL	MIN.	MAX.	UNIT
Power Supply Voltage for LCD	VCC	0	4.0	V
Lamp Voltage	VL	0	T.B.D.	Vrms
Lamp Current	IL	0	T.B.D.	mArms
Lamp Frequency	FL	--	T.B.D.	kHz
Operation Temperature *1)	T _{op}	0	50	°C
Storage Temperature *1)	T _{stg}	-20	60	°C

[Note]

*1) Top, Tstg ≤ 40°C : 90% RH max. without condensation

Top, Tstg > 40°C : Absolute humidity shall be less than the value of 90% RH at 40°C without condensation.

3. ELECTRICAL CHARACTERISTICS

(1) TFT- LCD

Ambient Temperature: Ta = 25°C

ITEM	SYMBOL	MIN.	TYP.	MAX.	UNIT	Remarks
Power Supply Voltages for LCD *)	VCC	3.0	3.3	3.6	V	Note A) (See next page)
Power Supply Currents for LCD	ICC	--	T.B.D.	--	mA	Note B) (See next page)

*) at the Input connector

(2) Backlight

Ta = 25°C

ITEM	SYMBOL	MIN.	TYP.	MAX.	UNIT	Remarks
Lamp Voltage	VL	--	T.B.D.	--	Vrms	IL = 6.0 mArms
Lamp Current *1)	IL	--	6.0	--	mArms	*1)
Starting Lamp Voltage	VS	T.B.D.	--	--	Vrms	Ta = 25°C
		T.B.D.	--	--	Vrms	Ta = 0°C
Lamp Frequency *2)	FL	T.B.D.	--	T.B.D.	kHz	*2)
Lamp Life Time	LT	50,000	--	--	h	IL = 6.0 mArms Continuous Operation

*1) Lamp Current measurement method (The current meter is inserted in low voltage line.)

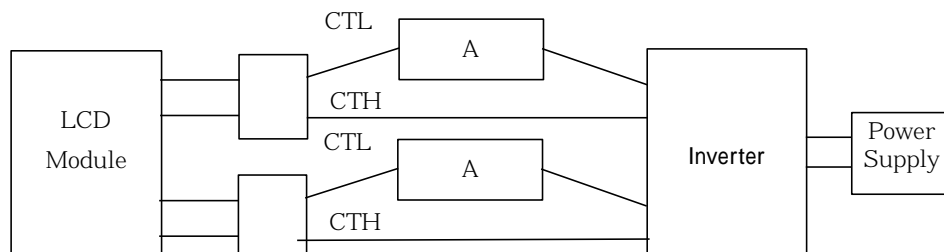

*2) Lamp frequency of inverter may produce interference with horizontal synchronous frequency, and this may cause horizontal beat on the display. Therefore, please adjust lamp frequency, and keep inverter as far from module as possible or use electronic shielding between inverter and module to avoid the interference.

[Note]

A) Power and signals sequence:

$$\begin{aligned} t1 &\leq \text{T.B.D.} & \text{T.B.D.} &\leq t5 \\ 0 < t2 &\leq \text{T.B.D.} & \text{T.B.D.} &\leq t6 \\ 0 < t3 &\leq \text{T.B.D.} & 0 &\leq t7 \\ t4 &\leq \text{T.B.D.} \end{aligned}$$

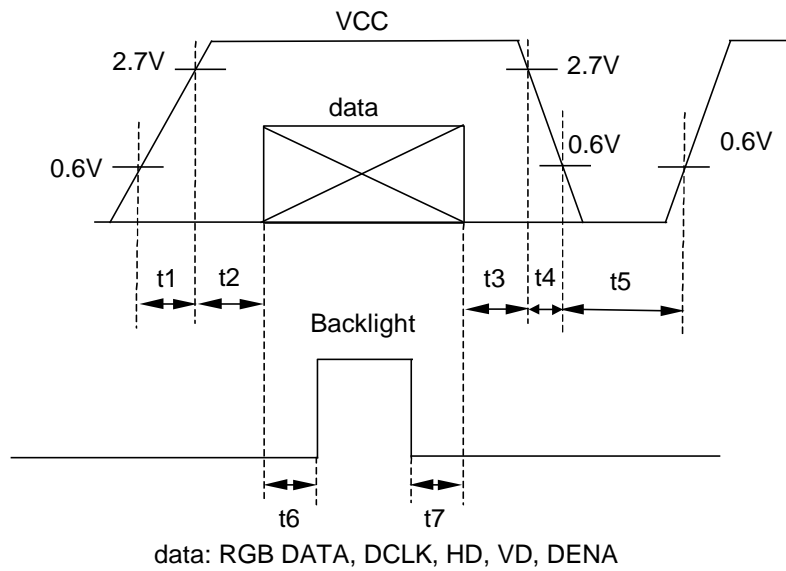

VCC-dip conditions:

- 1) When $2.4 \text{ V} \leq \text{VCC} < 3.0 \text{ V}$, $t_d \leq 10 \text{ ms}$
- 2) When $\text{VCC} < 2.4 \text{ V}$

VCC-dip conditions shall also follow the power and signals sequence.

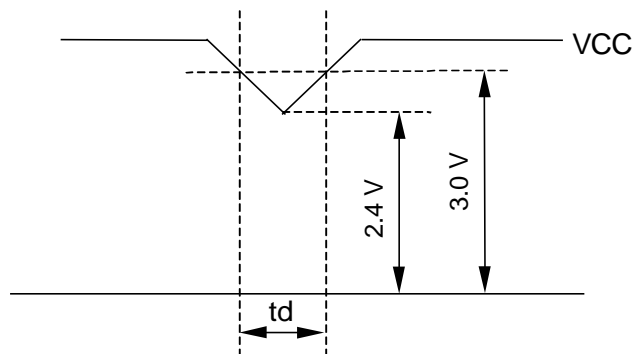

B) Current condition:

Typical: 64- gray- bar-pattern

$\text{VCC} = 3.3 \text{ V}$, $f_H = 48.4 \text{ kHz}$, $f_V = 60 \text{ Hz}$, $f_{\text{CLK}} = 65 \text{ MHz}$

4. INTERFACE PIN CONNECTION

CN 1(INTERFACE SIGNAL)

Used connector: FI-SEB20P-HF(JAE)

Corresponding connector: FI-S20S[for discrete Wire],FI-SE20M[for SMT]

Pin No.	Symbol	機能
1	VCC	+3.3V Power supply
2	VCC	+3.3V Power supply
3	GND	
4	GND	
5	Link 0-	R0, R1, R2, R3, R4, R5, G0 *)
6	Link 0+	R0, R1, R2, R3, R4, R5, G0 *)
7	GND	
8	Link 1-	G1, G2, G3, G4, G5, B0, B1 *)
9	Link 1+	G1, G2, G3, G4, G5, B0, B1 *)
10	GND	
11	Link 2-	B2, B3, B4, B5, HD, VD, DENA *)
12	Link 2+	B2, B3, B4, B5, HD, VD, DENA *)
13	GND	
14	CLKIN-	Clock-
15	CLKIN+	Clock+
16	GND	
17	N.C.	No connection
18	TEST	This pin shall be open. Test signal output for only internal test use.
19	TEST	This pin shall be open. Test signal output for only internal test use.
20	SC	High:Reverse Scan , Low:Normal Scan

*) See; Timing Chart(P8) and LVDS Data Mapping(P9)

CN 2,3 (BACKLIGHT)

Backlight-side connector: BHSR-03VS-1(JST)

Inverter-side connector: SM02(8.0)B-BHS-1-TB(JST)[for SMT]

BHMR-030(JST)[for discrete Wire]

Pin No.	Symbol	Function
1	CTH	VBLH (High Voltage)
3	CTL	VBLL (Low Voltage)

[Note]

VBLH-VBLL = VL

5. INTERFACE TIMING

(1) Timing Specifications

ITEM		SYMBOL	MIN.	TYP.	MAX.	UNIT		
LCD Timing LVDS Transmitter Input	DCLK	Frequency	f_{CLK}	43.6	65	66.6	MHz	
		Period	t_{CLK}	15	15.4	22.9	ns	
	DENA	Horizontal Active Time	t_{HA}	1024	1024	1024	t_{CLK}	
		Horizontal Front Porch	t_{HFP}	0	24	--	t_{CLK}	
		Horizontal Back Porch	t_{HBP}	4	296	--	t_{CLK}	
		Vertical Active Time	t_{VA}	768	768	768	t_H	
		Vertical Front Porch	t_{VFP}	2	3	--	t_H	
		Vertical Back Porch	t_{VBP}	1	35	--	t_H	
		HD	Frequency	f_H	42.4	48.4	55.9	kHz
	Period		t_H	17.9	20.7	23.6	μs	
	Low Width		t_{WHL}	1	136	--	t_{CLK}	
	VD		Frequency	f_V	55	60	62	Hz
			Period	t_V	16.1	16.7	18.2	ms
			Low Width	t_{WVL}	1	6	--	t_H

[Note]

- 1) Polarities of HD and VD are negative in this specification.
- 2) DENA (Data Enable) shall always be positive polarity as shown in the timing specification.
- 3) DCLK shall appear during all invalid period, and HD shall appear during invalid period of frame cycle.
- 4) LVDS timing follows the timing specifications of LVDS receiver IC: THC63LVDF84A(Thine).

(2) Timing Chart

a. Horizontal Timing Chart

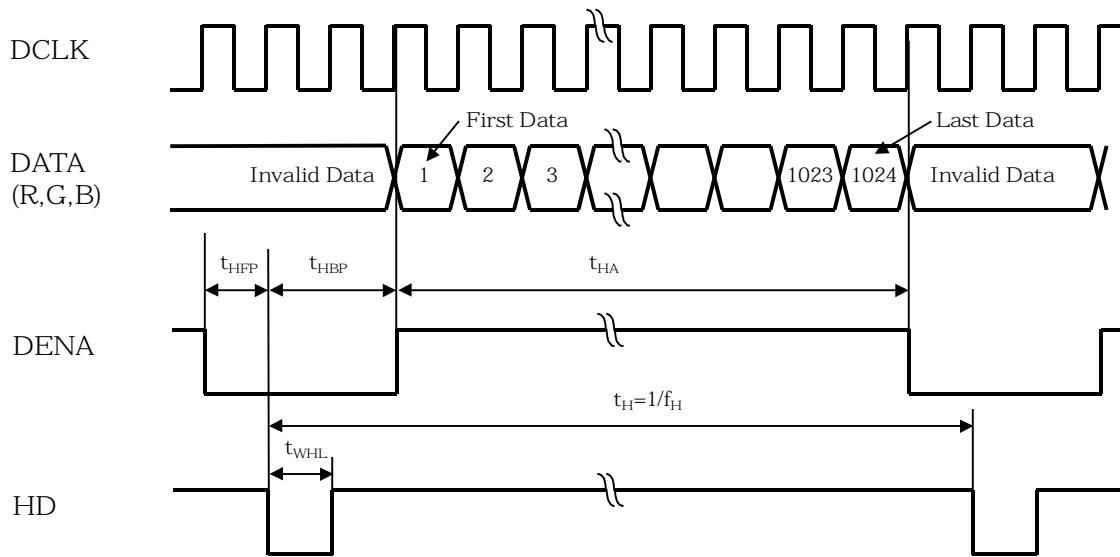

b. Vertical Timing Chart

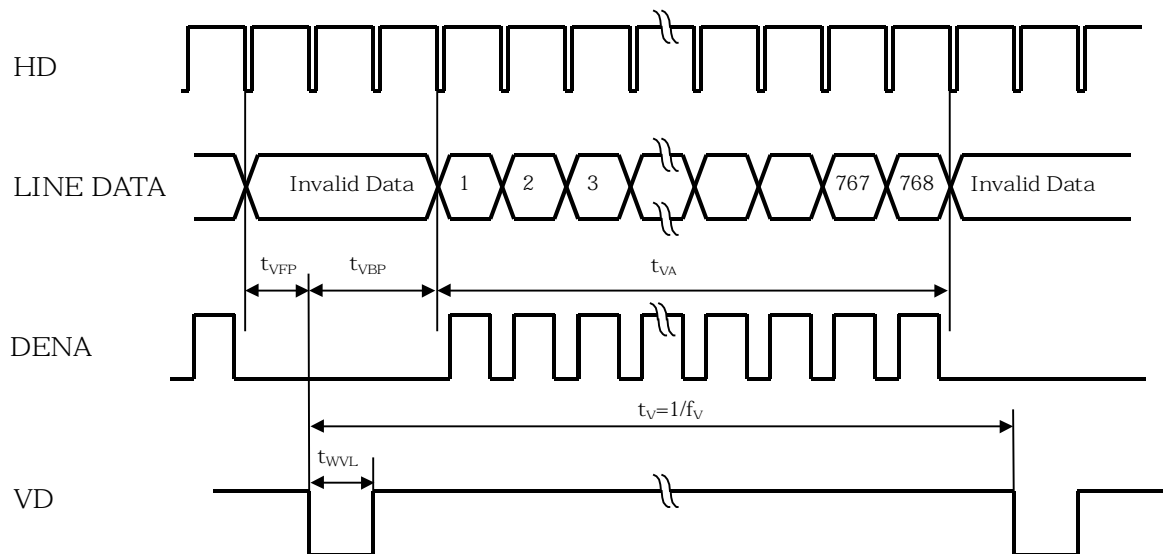

(3) LVDS Data Mapping

Cell	Input pin *)	Data
P0C1	TxIN0	R0
P0C2	TxIN1	R1
P0C3	TxIN2	R2
P0C4	TxIN3	R3
P0C5	TxIN4	R4
P0C6	TxIN5	R5
P0C7	TxIN6	G0
P1C1	TxIN7	G1
P1C2	TxIN8	G2
P1C3	TxIN9	G3
P1C4	TxIN10	G4
P1C5	TxIN11	G5
P1C6	TxIN12	B0
P1C7	TxIN13	B1
P2C1	TxIN14	B2
P2C2	TxIN15	B3
P2C3	TxIN16	B4
P2C4	TxIN17	B5
P2C5	TxIN18	HD
P2C6	TxIN19	VD
P2C7	TxIN20	DENA
Ref-CLK1	TxCLKIN	DCLK

*) : Pin definition of DS90C363(NS)

(4) Color Data Assignment

COLOR	INPUT DATA	R DATA						G DATA						B DATA					
		R5	R4	R3	R2	R1	R0	G5	G4	G3	G2	G1	G0	B5	B4	B3	B2	B1	B0
		MSB			LSB			MSB			LSB			MSB			LSB		
BASIC COLOR	BLACK	0	0	0	0	0	0	0	0	0	0	0	0	0	0	0	0	0	0
	RED(63)	1	1	1	1	1	1	0	0	0	0	0	0	0	0	0	0	0	0
	GREEN(63)	0	0	0	0	0	0	1	1	1	1	1	1	0	0	0	0	0	0
	BLUE(63)	0	0	0	0	0	0	0	0	0	0	0	0	1	1	1	1	1	1
	CYAN	0	0	0	0	0	0	1	1	1	1	1	1	1	1	1	1	1	1
	MAGENTA	1	1	1	1	1	1	0	0	0	0	0	0	1	1	1	1	1	1
	YELLOW	1	1	1	1	1	1	1	1	1	1	1	1	0	0	0	0	0	0
	WHITE	1	1	1	1	1	1	1	1	1	1	1	1	1	1	1	1	1	1
RED	RED(0)	0	0	0	0	0	0	0	0	0	0	0	0	0	0	0	0	0	0
	RED (1)	0	0	0	0	0	1	0	0	0	0	0	0	0	0	0	0	0	0
	RED(2)	0	0	0	0	1	0	0	0	0	0	0	0	0	0	0	0	0	0
	RED (62)	1	1	1	1	1	0	0	0	0	0	0	0	0	0	0	0	0	0
	RED(63)	1	1	1	1	1	1	0	0	0	0	0	0	0	0	0	0	0	0
GREEN	GREEN(0)	0	0	0	0	0	0	0	0	0	0	0	0	0	0	0	0	0	0
	GREEN (1)	0	0	0	0	0	0	0	0	0	0	0	1	0	0	0	0	0	0
	GREEN(2)	0	0	0	0	0	0	0	0	0	0	1	0	0	0	0	0	0	0
	GREEN(62)	0	0	0	0	0	0	1	1	1	1	1	0	0	0	0	0	0	0
	GREEN(63)	0	0	0	0	0	0	1	1	1	1	1	1	0	0	0	0	0	0
BLUE	BLUE(0)	0	0	0	0	0	0	0	0	0	0	0	0	0	0	0	0	0	0
	BLUE(1)	0	0	0	0	0	0	0	0	0	0	0	0	0	0	0	0	0	1
	BLUE(2)	0	0	0	0	0	0	0	0	0	0	0	0	0	0	0	0	1	0
	BLUE(62)	0	0	0	0	0	0	0	0	0	0	0	0	1	1	1	1	1	0
	BLUE(63)	0	0	0	0	0	0	0	0	0	0	0	0	1	1	1	1	1	1

[Note]

- 1) Definition of gray scale
 Color (n) ---n indicates gray scale level.
 Higher n means brighter level.
- 2) Data
 1:High, 0: Low

6. BLOCK DIAGLAM

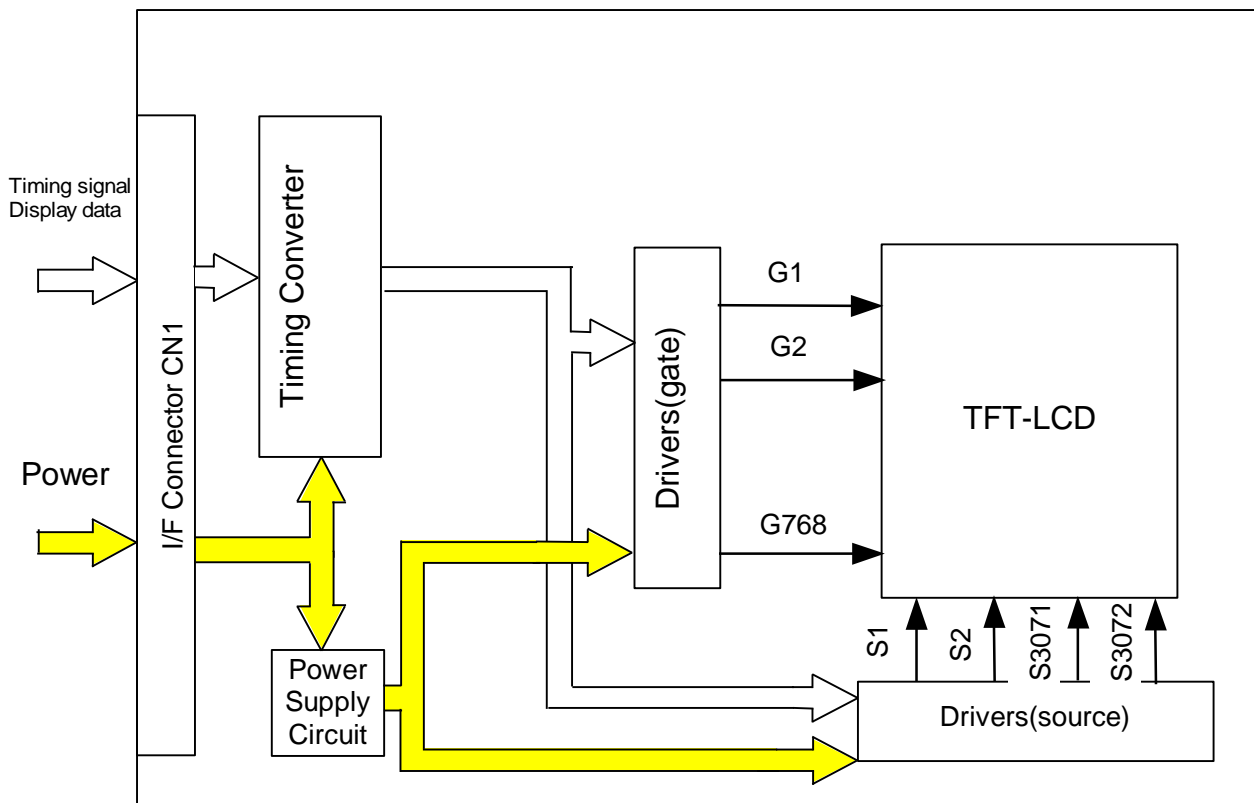

BACKLIGHT

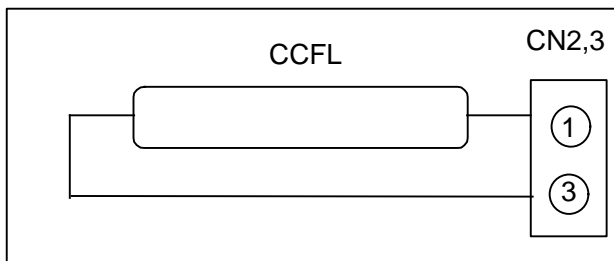

7. MECHANICAL SPECIFICATIONS

(1) Front Side

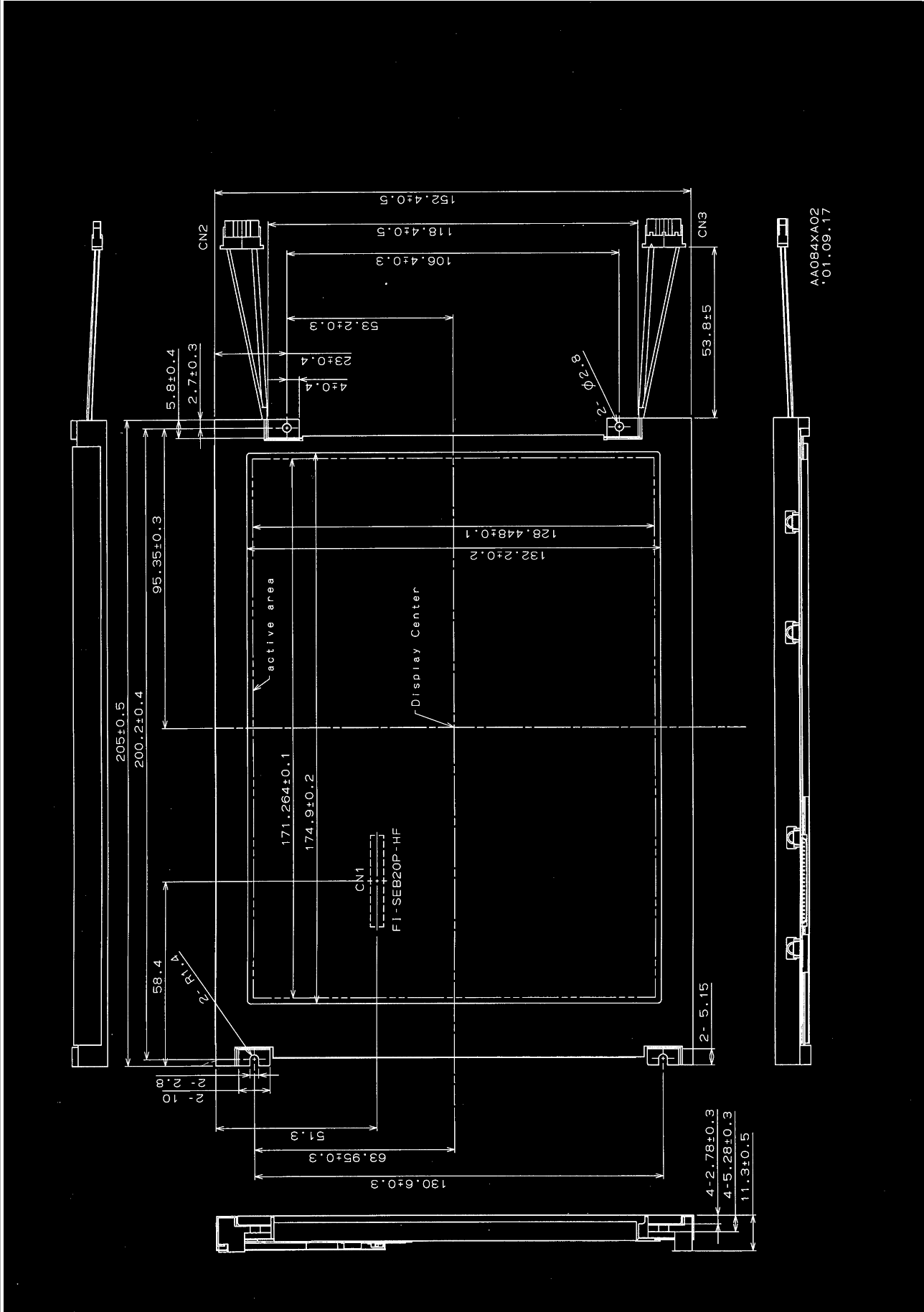

(2) Rear Side

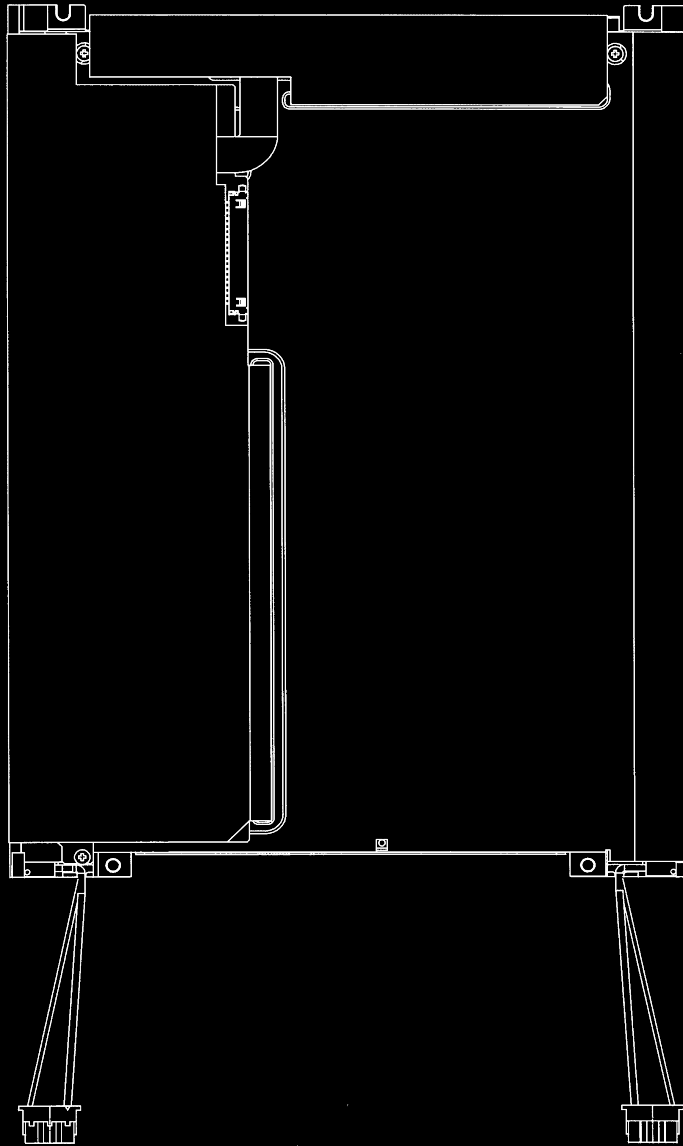

AA084XA02
*01.09.19

[Note]

We recommend you referring to the detailed drawing for your design.

Please contact our company sales representative when you need the detailed drawing.

8. OPTICAL CHARACTERISTICS

Ta = 25°C, VCC = 3.3 V, Input Signals: Typ. Values shown in Section 5

ITEM		SYMBOL	CONDITION	MIN.	TYP.	MAX.	UNIT	Remarks
Contrast Ratio		CR	$\theta = \phi = 0^\circ$	--	350	--	--	*1)*3)
Luminance		Lw	$\theta = \phi = 0^\circ$	--	300	--	cd/m ²	*2)*3)
Response Time		tr	$\theta = \phi = 0^\circ$	--	6	--	ms	*3)*4)
		tf	$\theta = \phi = 0^\circ$	--	19	--	ms	*3)*4)
Viewing Angle	Horizontal	ϕ	CR ≥ 10	--	-60~60	--	°	*3)
	Vertical	θ		--	-40~50	--	°	*3)
Color Coordinates	Red	Rx	$\theta = \phi = 0^\circ$	--	0.58	--	--	*3)
		Ry		--	0.34	--		
	Green	Gx		--	0.33	--		
		Gy		--	0.52	--		
	Blue	Bx		--	0.16	--		
		By		--	0.16	--		
White	Wx	--	0.33	--				
	Wy	--	0.34	--				

[Note]

These items are measured using CS-1000(MINOLTA) or LCD-7000(Otsuka Electronic) under the dark room condition (no ambient light).

Condition: IL = 6.0 mArms, FL = T.B.D. kHz

*1) Definition of Contrast Ratio

CR = ON (White) Luminance / OFF(Black) Luminance

*2) Definition of Luminance

Lw = ON (White) Luminance: average of 5 points

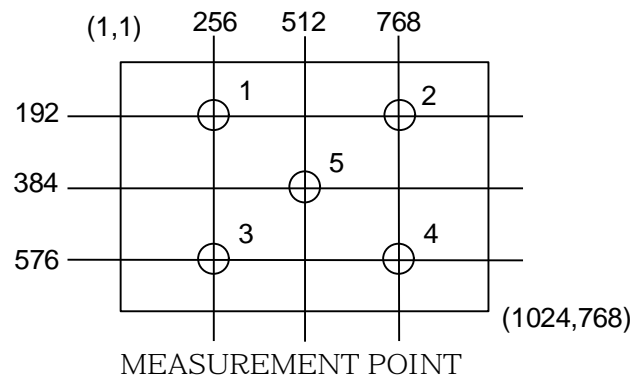

*3) Definition of Viewing Angle(θ , ϕ)

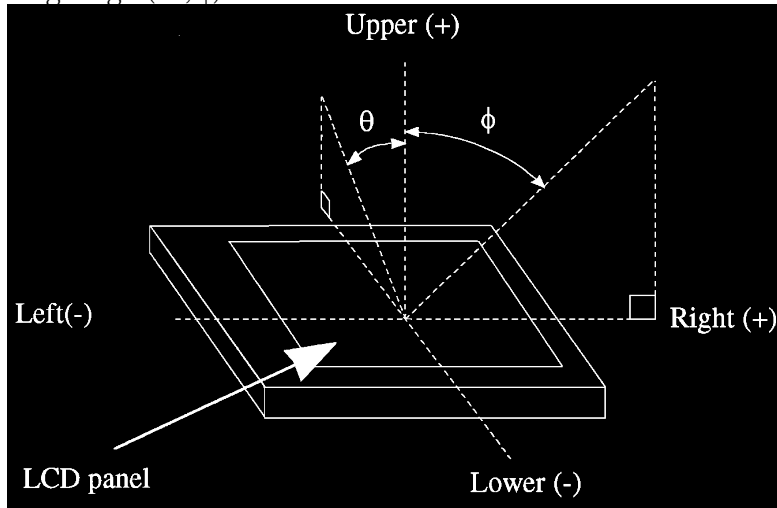

*4) Definition of Response Time

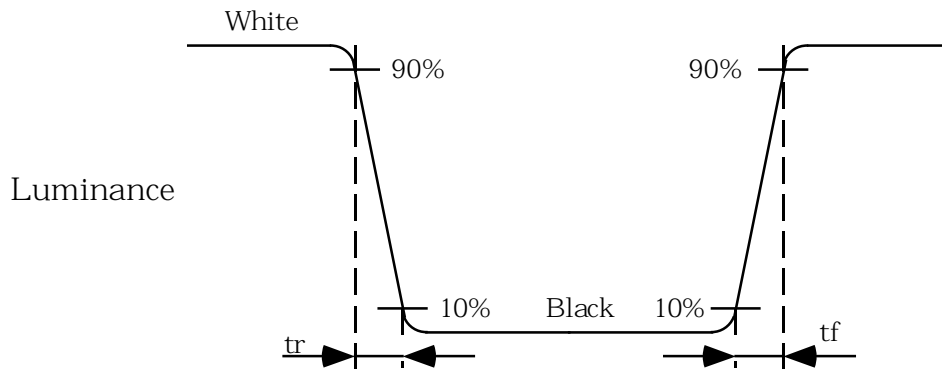

9. RELIABILITY TEST CONDITION

(1) Temperature and Humidity

TEST ITEM	CONDITIONS
HIGH TEMPERATURE HIGH HUMIDITY OPERATION	40°C, 90%RH, 240 h (No condensation)
HIGH TEMPERATURE STORAGE	60°C, 96 h
LOW TEMPERATURE STORAGE	-20°C, 96 h
THERMAL SHOCK	BETWEEN -20°C (1h) and 60°C(1h), 5 CYCLES

(2) Shock & Vibration

ITEM	CONDITIONS
SHOCK (NON-OPERATION)	Shock level: 980 m/s ² (100 G) Waveform: half sinusoidal wave, 2 ms Number of shocks: one shock input in each direction of three mutually Perpendicular axes for a total of six shock inputs
VIBRATION (NON-OPERATION)	Vibration level: 9.8 m/s ² (1.0 G) Waveform: sinusoidal Frequency range: 5 to 500Hz Frequency sweep rate: 0.5 octave /min Duration: one sweep from 5 to 500 Hz in each of three mutually Perpendicular axis(each x,y,z axis: 1 hour, total 3 hours)

(3) Judgment standard

The judgment of the above tests should be made as follow:

Pass: Normal display image with no obvious non-uniformity and no line defect.

Partial transformation of the module parts should be ignored.

Fail: No display image, obvious non-uniformity, or line defects.

10. INVERTED SCAN CAPABILITY

This module has the capability of inverting scan direction by signaling from controller.

Note that scan direction cannot be changed during operation.

The following figure shows the relation between the display position and the scan direction.

DISPLAY POSITION

Normal scan: SC = "L"

D(1, 1)	D(2, 1)	---	D(X, 1)	---	D(1023, 1)	D(1024, 1)
D(1, 2)	D(2, 2)	---	D(X, 2)	---	D(1023, 2)	D(1024, 2)
↓	↓	+	+	+	↓	↓
D(1, Y)	D(2, Y)	---	D(X, Y)	---	D(1023, Y)	D(1024, Y)
↓	↓	+	+	+	↓	↓
D(1,767)	D(2,767)	---	D(X,767)	---	D(1023,767)	D(1024,767)
D(1,768)	D(2,768)	---	D(X,768)	---	D(1023,768)	D(1024,768)

Reverse scan: SC = "H"

D(1024,768)	D(1023,768)	---	D(X,768)	---	D(2,768)	D(1,768)
D(1024,767)	D(1023,767)	---	D(X,767)	---	D(2,767)	D(1,767)
↓	↓	+	+	+	↓	↓
D(1024, Y)	D(1023, Y)	---	D(X, Y)	---	D(2, Y)	D(1, Y)
↓	↓	+	+	+	↓	↓
D(1024, 2)	D(1023, 2)	---	D(X, 2)	---	D(2, 2)	D(1, 2)
D(1024, 1)	D(1023, 1)	---	D(X, 1)	---	D(2, 1)	D(1, 1)

The following drawings shows the relationship between the viewing direction and the scan direction.

Normal scan

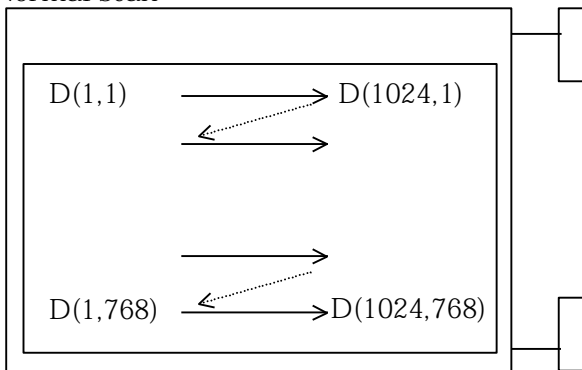

Reverse scan

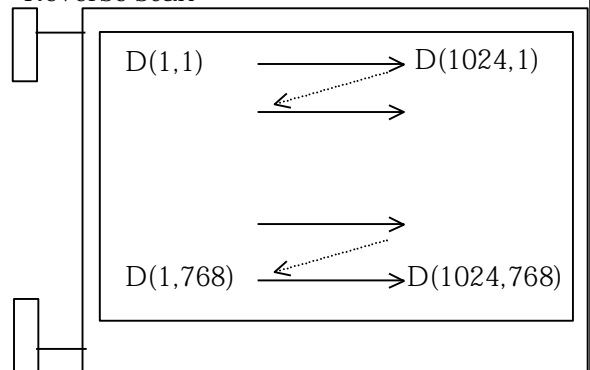

11. HANDLING PRECAUTIONS FOR TFT-LCD MODULE

Please pay attention to the followings in handling TFT-LCD products;

(1) ASSEMBLY PRECAUTION

- a. Please use the mounting hole on the module in installing and do not bending or wrenching LCD in assembling. And please do not drop, bend or twist LCD module in handling.
- b. Please design display housing in accordance with the following guide lines.
 - (a) Housing case must be designed carefully so as not to put stresses on LCD all sides and not to wrench module. The stresses may cause non-uniformity even if there is no non-uniformity statically.
 - (b) Keep sufficient clearance between LCD module back surface and housing when the LCD module is mounted. Approximately 1.0mm of the clearance in the design is recommended taking into account the tolerance of LCD module thickness and mounting structure height on the housing.
 - (c) When some parts, such as, FPC cable and ferrite plate, are installed underneath the LCD module, still sufficient clearance is required, such as 0.5 mm. This clearance is, especially, to be reconsidered when the additional parts are implemented for EMI countermeasure.
 - (d) Design the inverter location and connector position carefully so as not to give stress to lamp cable, or not to interface the LCD module by the lamp cable.
 - (e) Keep sufficient clearance between LCD module and the others parts, such as inverter and speaker so as not to interface the LCD module. Approximately 1.0 mm of the clearance in the design is recommended.
- c. Please do not push or scratch LCD panel surface with anything hard. And do not soil LCD panel surface by touching with bare hands. (Polarizer film, surface of LCD panel is easy to be flawed.)
- d. Please do not press any parts on the rear side such as source TCP, gate TCP, control circuit board and FPCs during handling LCD module. If pressing rear part is unavoidable, handle the LCD module with care not to damage them.
- e. Please wipe off LCD panel surface with absorbent cotton or soft cloth in case of it being soiled.
- f. Please wipe off drops of adhesives like saliva and water on LCD panel surface immediately. They might damage to cause panel surface variation and color change.
- g. Please do not take a LCD module to pieces and reconstruct it. Resolving and reconstructing modules may cause them not to work well.
- h. Please do not touch metal frames with bare hands and soiled gloves. A color change of the metal frames can happen during a long preservation of soiled LCD modules.
- i. Please pay attention to handling lead wire of backlight so that it is not tugged in connecting

with inverter.

- j. Please connect the metal frame of LCD module to GND in order to minimize the effect of external noise and EMI.
- k. Be sure to connect the cables and the connectors correctly.

(2) OPERATING PRECAUTIONS

- a. Please be sure to turn off the power supply before connecting and disconnecting signal input cable.
- b. Please do not change variable resistance settings in LCD module. They are adjusted to the most suitable value. If they are changed, it might happen LCD does not satisfy the characteristics specification.
- c. LCD backlight takes longer time to become stable of radiation characteristics in low temperature than in room temperature.
- d. A condensation might happen on the surface and inside of LCD module in case of sudden change of ambient temperature.
- e. Please pay attention not to display the same pattern for very long time. Image might stick on LCD. Even if image sticking happens, it may disappear as the operation time proceeds.
- f. Please obey the same safe instructions as ones being prepared for ordinary electronic products.

(3) PRECAUTIONS WITH ELECTROSTATICS

- a. This LCD module use CMOS-IC on circuit board and TFT-LCD panel, and so it is easy to be affected by electrostatics. Please be careful with electrostatics by the way of your body connecting to the ground and so on.
- b. Please remove protection film very slowly from the surface of LCD module to prevent from electrostatics occurrence.

(4) STORAGE PRECAUTIONS

- a. Please do not leave the LCDs in the environment of high humidity and high temperature such as 60°C/90%RH.
- b. Please do not leave the LCDs in the environment of low temperature; below -20°C.

(5) SAFETY PRECAUTIONS

- a. When you waste damaged or unnecessary LCDs, it is recommended to crush LCDs into pieces and wash them off with solvents such as acetone and ethanol, which should later be burned.

- b. If any liquid leaks out of a damaged glass cell and comes in contact with the hands, wash off thoroughly with soap and water.
- c. Be sure to turn off the power supply when inserting or disconnecting the cable.
- d. Inverter should be designed carefully so as not to keep working in case of detecting over current or open circuit on the lamp.

(6) OTHERS

- a. A strong incident light into LCD panel might cause display characteristics changing inferior because of polarizer film, color filter, and other materials becoming inferior. Please do not expose LCD module direct sunlight and strong UV rays.
- b. Please pay attention to a panel side of LCD module not to contact with other materials in preserving it alone.
- c. For the packaging box, please pay attention to the followings;
 - (a) Packaging box and inner case for LCD are designed to protect the LCDs from the damage or scratching during transportation. Please do not open except picking LCDs up from the box.
 - (b) Please do not pile them up more than 5 boxes. (They are not designed so.) And please do not turn over.
 - (c) Please handle packaging box with care not to give them sudden shock and vibrations. And also please do not throw them up.
 - (d) Packaging box and inner case for LCDs are made of cardboard. So please pay attention not to get them wet. (Such like keeping them in high humidity or wet place can occur getting them wet.)