



ELECTRONICS

Approval

TO :

DATE :

SAMSUNG TFT-LCD
MODEL NO. : LTM150XH-L04

APPROVED BY :

Any Modification of Spec is not allowed without SEC's permission.

Approved by : 

PREPARED BY : AMLCD Technical Customer Service Team

SAMSUNG ELECTRONICS CO., LTD.

CONTENTS

Approval

Revision History	----- (3)
General Description	----- (4)
1. Absolute Maximum Ratings	----- (5)
1.1 Absolute Ratings Of Environment	
1.2 Electrical Absolute Ratings	
2. Optical Characteristics	----- (7)
3. Electrical Characteristics	----- (10)
3.1 TFT LCD Module	
3.2 Back-light Unit	
4. Block Diagram	----- (13)
4.1 TFT LCD Module	
4.2 Back-light Unit	
5. Input Terminal Pin Assignment	----- (14)
5.1 Input Signal & Power	
5.2 LVDS Interface	
5.3 Back-light Unit	
5.4 Input Signals, Basic Display Colors and Gray Scale of Each Color	
5.5 Pixel format	
6. Interface Timing	----- (18)
6.1 Timing Parameters (DE only mode)	
6.2 Timing Diagrams of interface Signal (DE only mode)	
6.3 Interface timing diagrams of LVDS	
6.4 Power ON/OFF Sequence	
7. Outline Dimension	----- (22)
8. Reliability Test	----- (24)
9. Packing	----- (25)
10. Marking & Others	----- (26)
11. General Precaution	----- (28)

Revision History

Approval

Date	Rev.No.	Page	Summary
May 25, 2001	000		Approval spec of LTM150XH -L04 model is issued for the first time.

Doc.No.

LTM150XH-L04

Rev.No

04 - 000 - G - 010525

Page

3 /29

GENERAL DESCRIPTION

DESCRIPTION

LTM150XH-L04 is a color active matrix TFT (Thin Film Transistor) liquid crystal display that uses amorphous silicon TFT switching devices. This model is composed of a TFT LCD panel, a driver circuit and a back-light system. The resolution of 15.0- inch contains 1,024 x 768 pixels and can display up to 16.2M colors. 6 o'clock direction is the optimum viewing angle.

FEATURES

- High contrast ratio, High aperture structure
- Wide viewing angle
- High-speed response
- XGA(1024x768 pixels) resolution
- 8-bit color depth, Display 16.2M colors
- Low power consumption
- 4 CCFTs (Cold Cathode Fluorescent Tube)
- DE Only Mode
- LVDS Interface with 1 pixel / clock

APPLICATIONS

- Desktop monitors
- Display terminals for AV application products
- Monitors for Industrial machine

GENERAL SPECIFICATIONS

ITEM	SPECIFICATION	UNIT	NOTE
Active area	304.1(H) x228.1(V) (15.0 inch diagonal)	mm	
Driver element	a-Si TFT active matrix		
Display colors	16,194,277		
Number of pixel	1024 x 768	pixel	
Pixel arrangement	RGB vertical stripe		
Pixel pitch	0.297(H) x 0.297(W)	mm	
Display Mode	Normally white		
Surface treatment	Haze 25 , Anti-glare & Hard - Coating (3H)		

Mechanical Information

ITEM		MIN.	TYP.	MAX.	NOTE
Module size	Horizontal (H)	331.1	331.6	332.1	mm
	Vertical (V)	254.4	254.9	255.4	mm
	Depth (D)	-	12.5	13.0	mm
Weight		-	-	1350	g

1. ABSOLUTE MAXIMUM RATINGS**1.1 ABSOLUTE RATINGS OF ENVIRONMENT**

ITEM	SYMBOL	MIN.	MAX.	UNIT	NOTE
Storage temperature	T_{STG}	-20	60	°C	(1),(5)
Operating temperature (Surface of Glass)	T_{OPR}	0	50	°C	(1),(5)
Shock (non-operating)	Snop	-	50	G	(2),(4)
Vibration (non-operating)	Vnop	-	1.5	G	(3),(4)

Note (1) Temperature and relative humidity range are shown in the figure below.

90 % RH Max. ($40\text{ }^{\circ}\text{C} \geq T_a$)

Maximum wet - bulb temperature at $39\text{ }^{\circ}\text{C}$ or less. ($T_a > 40\text{ }^{\circ}\text{C}$) No condensation.

(2) 11ms, sine wave, 1 time for $\pm X, \pm Y, \pm Z$.

(3) 10 - 300 - 10 Hz, Sweep rate: 10 min, 30 min for X,Y,Z.

(4) At testing Vibration and Shock, the fixture in holding the Module to be tested have to be hard and rigid enough so that the Module would not be twisted or bent by the fixture.

(5) If product is used for extended time excessively or exposed to high temperatures for extended time, there is a possibility of wide viewing angle film damage which could affect visual characteristics.

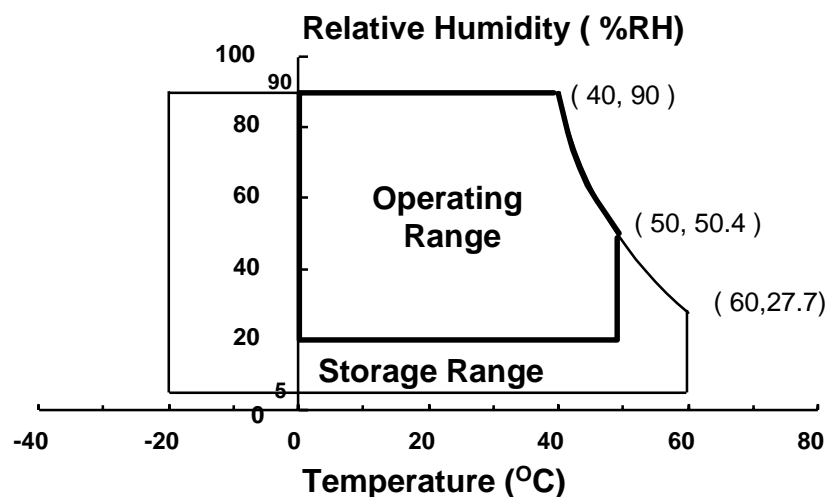

1.2 ELECTRICAL ABSOLUTE RATINGS

(1) TFT LCD MODULE

(V_{SS} = GND = 0 V)

ITEM	SYMBOL	MIN.	MAX.	UNIT	NOTE
Power Supply Voltage	V _{DD}	GND-0.3	3.6	V	(1)

NOTE (1) With Ta (25 ± 2 °C)

(2) BACK-LIGHT UNIT

Ta = 25 ± 2 °C

ITEM	SYMBOL	MIN.	MAX.	UNIT.	NOTE
Lamp current	I _L	3.0	6.5	mA _{rms}	(1)
Lamp frequency	f _L	40	80	KHz	(1)

NOTE (1) Permanent damage to the device may occur if maximum values are exceeded.
Functional operation should be restricted to the conditions described under Normal Operating Conditions.

2. OPTICAL CHARACTERISTICS

The following items are measured under stable conditions. The optical characteristics should be measured in a dark room or equivalent state with the methods shown in Note (4).

Measuring equipment : TOPCON BM-5A

* $T_a = 25 \pm 2 \text{ }^\circ\text{C}$, $V_{DD} = 3.3\text{V}$, $f_v = 60\text{Hz}$, $f_{DCLK} = 65\text{MHz}$, $I_L = 6.0 \text{ mArms}$

ITEM		SYMBOL	CONDITION	MIN.	TYP.	MAX.	UNIT	NOTE	
Contrast Ratio (Center of screen)		CR		200	300	-		(1), (2), (4)	
Response Time at T_a	Rising	T_R	$\phi = 0,$ $\theta = 0$ Normal Viewing Angle	-	5	10	msec	(1), (3)	
	Falling	T_F		-	20	25			
Luminance of White (Center of screen)		Y_L			280	330	-	cd/m ²	(1), (4)
Color Chromaticity (CIE 1931)	Red	R_x		0.598	0.628	0.658			
		R_y		0.323	0.353	0.383			
	Green	G_x		0.260	0.290	0.320			
		G_y		0.565	0.595	0.625			
	Blue	B_x		0.114	0.144	0.174			
		B_y		0.058	0.088	0.118			
	White	W_x		0.274	0.304	0.334			
		W_y	0.295	0.325	0.355				
Viewing Angle	Hor.	θ_L	$CR \geq 5$	65	70	-	Degrees		
		θ_R		65	70	-			
	Ver.	ϕ_H		50	55	-			
		ϕ_L		55	60	-			
Brightness Uniformity		BUNI		-	-	20	%	(5)	

Note 1) Definition of Viewing Angle : Viewing angle range ($5 \leq CR$)

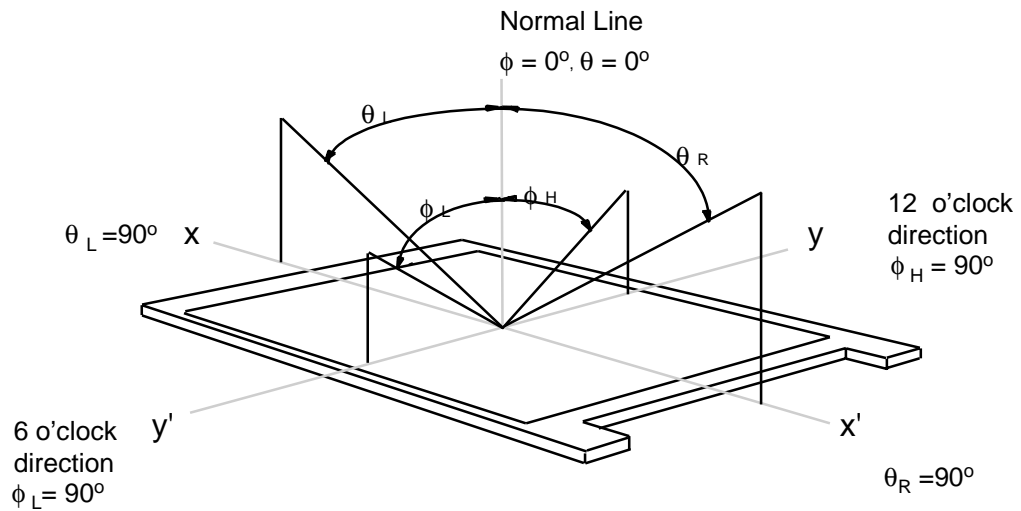

Note 2) Definition of Contrast Ratio (CR) : Ratio of gray max (Gmax) ,gray min (Gmin) at the center point of panel.

$$CR = \frac{\text{Luminance with all pixels white (Gmax)}}{\text{Luminance with all pixels black (Gmin)}}$$

Note 3) Definition of Response time : Sum of T_R, T_F

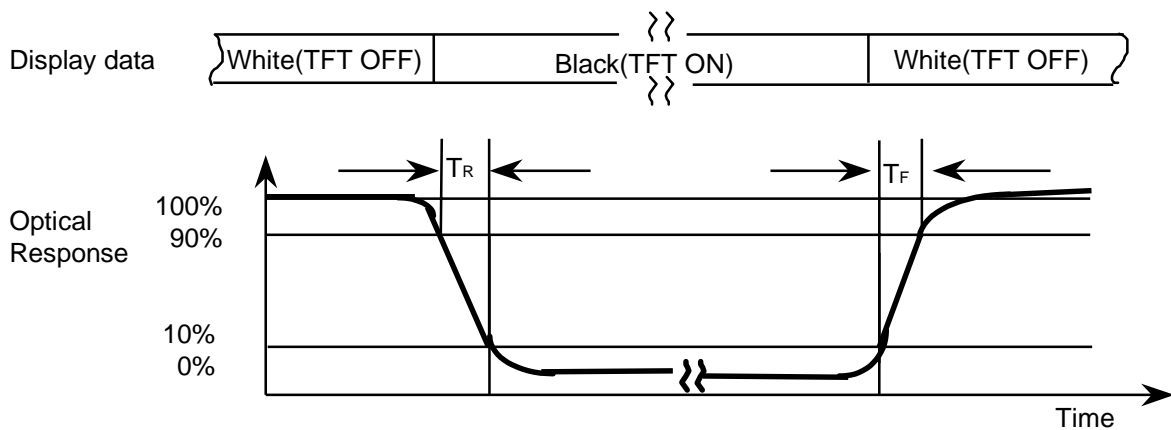

Note 4) After stabilizing and leaving the panel alone at a given temperature for 30 min , the measurement should be executed. Measurement should be executed in a stable, windless, and dark room. 30 min after lighting the back-light. This should be measured in the center of screen.
 Lamp current : 6.0mA , Environment condition : Ta = 25 ± 2 °C

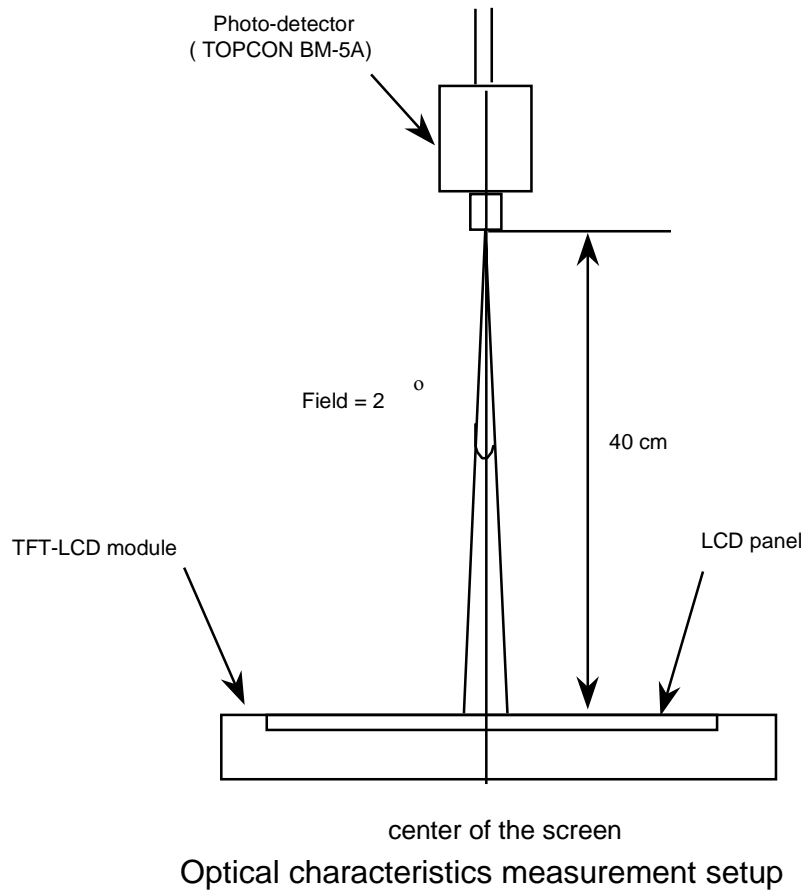

Note 5) Definition of 9 points brightness uniformity

$$B_{UNI} = \frac{|B_{max \text{ or } B_{min}} - B_{ave}|}{B_{ave}} \times 100$$

Bmax : Maximum Brightness

Bmin : Minimum Brightness

$$B_{ave} : \text{Average Brightness} = \frac{\sum_{k=1}^9 (B(k))}{9}$$

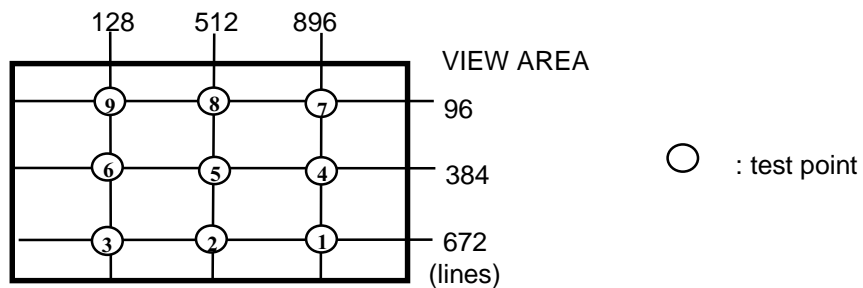

3. ELECTRICAL CHARACTERISTICS

3.1 TFT LCD MODULE

 $T_a = 25 \pm 2 \text{ }^\circ\text{C}$

ITEM	SYMBOL	MIN	TYP	MAX	UNIT	NOTE	
Voltage of Power Supply	V_{DD}	3.0	3.3	3.6	V		
Differential Input Threshold Voltage	High	V_{IH}	-	-	+100	mV	(1)
	Low	V_{IL}	-100	-	-	mV	
Current of Power Supply	White	I_{DD}	-	400	-	mA	(2)(4)*a
	Mosaic		-	420	-	mA	(2)(4)*b
	Sub-pixel checker		-	470	550	mA	(2)(4)*c
Vsync Frequency	f_V	-	60	75	Hz		
Hsync Frequency	f_H	-	48.3	60.0	kHz		
Main Frequency	f_{DCLK}	47	65	80	MHz	(3)	
Rush Current	I_{rush}	-	-	1.5	A	(5)	

Note (1) Condition : $V_{CM} = +1.2V$ (Typical)

(2) $f_V = 60\text{Hz}$, $f_{DCLK} = 65\text{MHz}$, $V_{DD} = 3.3V$, DC Current.

(3) 1 Pixel / clock

(4) Power dissipation check pattern

*a) White Pattern

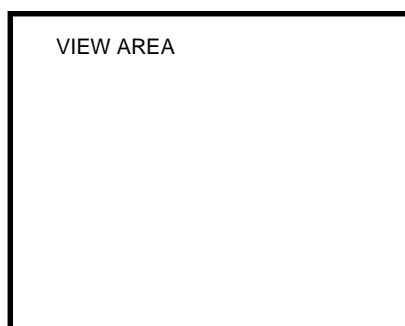

*b) Mosaic Pattern

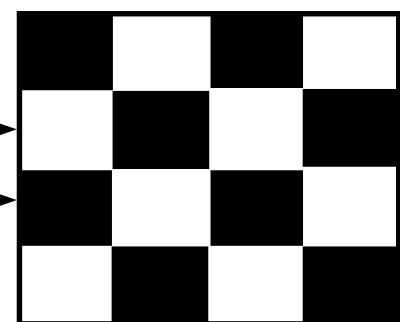

c) Sub-pixel Checker Pattern

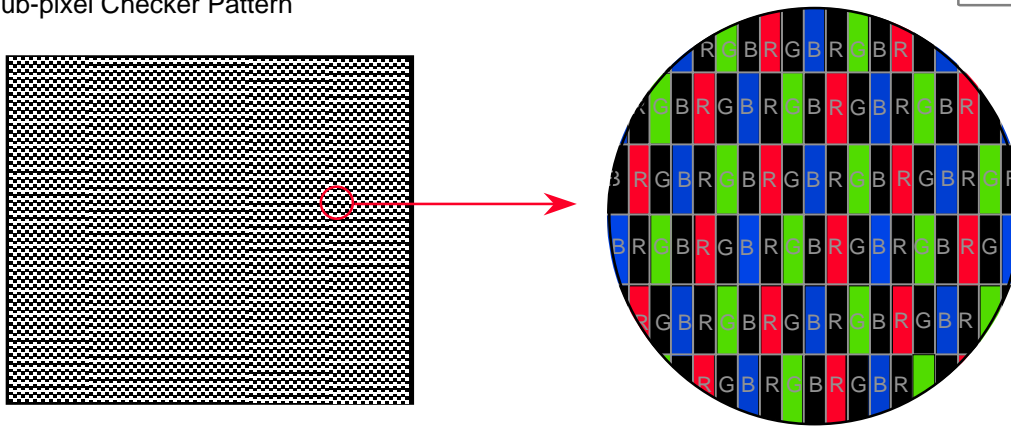

(5) Measurement Conditions

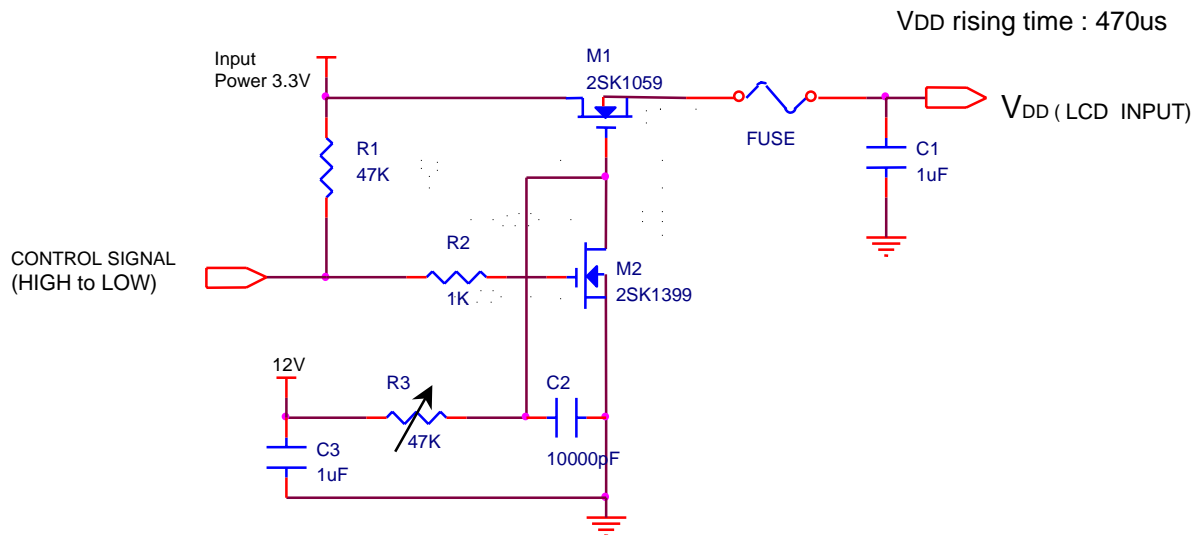

Note : Control Signal : High(+3.3V) -->Low(Ground)

All Signal lines to panel except for power 3.3V : Ground

The rising time of supplied voltage is controlled to 470us by R3 and C2 value.

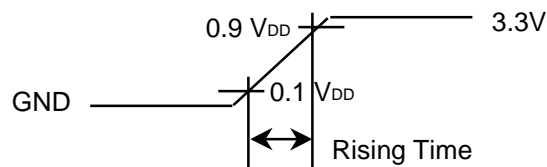

3.2 BACK-LIGHT UNIT

The back-light system is an edge-lighting type with 4 CCFTs(Cold Cathode Fluorescent Tube).

The characteristics of four lamps are shown in the following tables.

$T_a = 25 \pm 2 \text{ } ^\circ\text{C}$

ITEM	SYMBOL	MIN	TYP	MAX	UNIT	NOTE
Lamp Current	IL	3.0	6.0	6.5	mArms	(1)
Lamp Voltage	VL	-	665	-	Vrms	IL=6.0 mArms
Lamp Frequency	FL	40	-	60	kHz	(2)
Operating Life Time of Lamp	Hr	25,000	35,000	-	Hour	(3)
Startup Voltage	Vs	-	-	1120 (25°C)	Vrms	(4)
				1570 (0°C)		

Note) The waveform of the inverter output voltage must be area symmetric and the design of the inverter must have specifications for the modularized lamp.

The performance of the back-light, for example life time or brightness, is much influenced by the characteristics of the DC-AC inverter for the lamp. So all the parameters of an inverter should be carefully designed so as not to produce too much leakage current from high-voltage output of the inverter. When you design or order the inverter, please make sure that a poor lighting caused by the mismatch of the back-light and the inverter(miss lighting, flicker, etc.) never occur. When you confirm it, the module should be operated in the same condition as it is installed in your instrument.

Note (1) Lamp current is measured with current meter for high frequency as shown below.

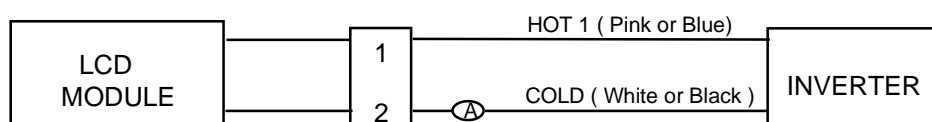

- (2) Lamp frequency may produce interference with horizontal synchronous frequency and this may cause line flow on the display. Therefore lamp frequency shall be detached from the horizontal synchronous frequency and its harmonics as far as possible in order to avoid interference.
- (3) Life time (Hr) of a lamp is defined as the time in which it continues to operate under the condition of $T_a = 25 \pm 2 \text{ } ^\circ\text{C}$ and $I_L = 6.0 \text{ mArms}$ until the brightness becomes 50% or lower than it's original value.
- (4) The voltage above this value should be applied to the lamps for more than 1 second to startup. Otherwise the lamps may not to be turned on.

4. BLOCK DIAGRAM

4.1 TFT LCD MODULE

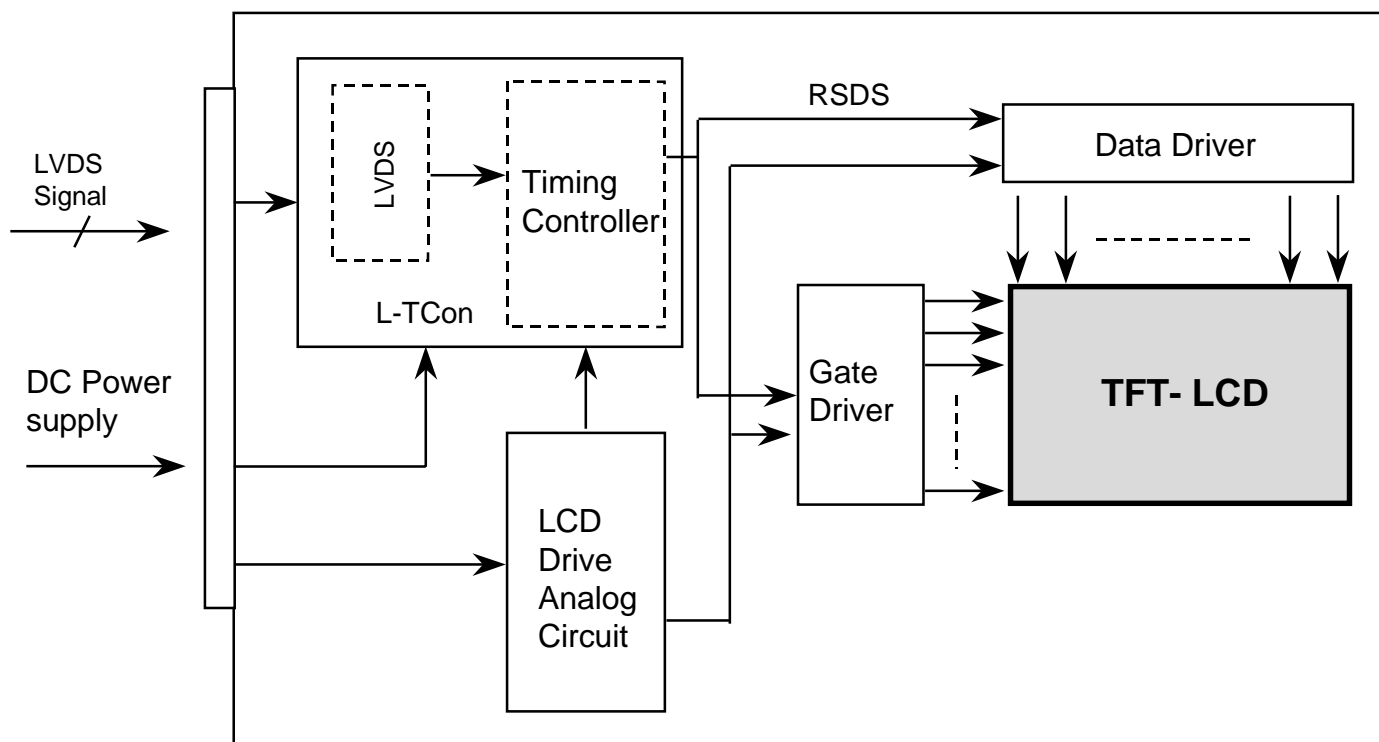

4.2 BACK-LIGHT UNIT

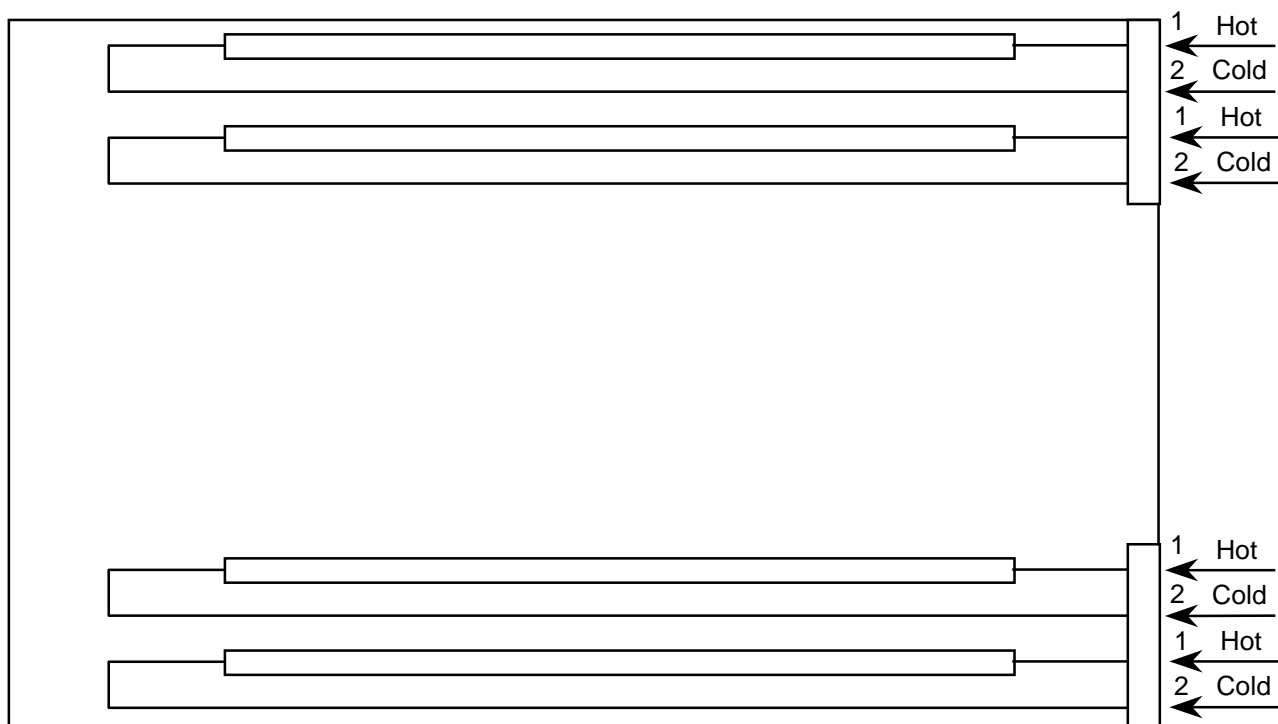

5. INPUT TERMINAL PIN ASSIGNMENT

5.1 Input Signal & Power (LVDS, Connector : Hirose DF14A-20P-1.25H)
Matching Socket : Hirose DF14-20S-1.25C

PIN NO	SYMBOL	FUNCTION	POLARITY	Output Pin# (LVDS Tx)
1	VDD	Power Supply +3.3 V		
2	VDD	Power Supply +3.3 V		
3	GND	Power Ground		
4	GND	Power Ground		
5	RXIN0 -	LVDS Receiver Signal(-)	Negative	PIN#48
6	RXIN0 +	LVDS Receiver Signal(+)	Positive	PIN#47
7	GND	Ground	-	
8	RXIN1 -	LVDS Receiver Signal(-)	Negative	PIN#46
9	RXIN1 +	LVDS Receiver Signal(+)	Positive	PIN#45
10	GND	Ground	-	
11	RXIN2 -	LVDS Receiver Signal(-)	Negative	PIN#42
12	RXIN2 +	LVDS Receiver Signal(+)	Positive	PIN#41
13	GND	Ground	-	
14	RXCLK IN -	LVDS Receiver Clock Signal(-)	Negative	PIN#40
15	RXCLK IN+	LVDS Receiver Clock Signal(+)	Positive	PIN#39
16	GND	Ground	-	
17	RXIN3 -	LVDS Receiver Signal(-)	Negative	PIN#38
18	RXIN3 +	LVDS Receiver Signal(+)	Positive	PIN#37
19	GND	Ground	-	
20	NC	Reserved	-	

LVDS INTERFACE

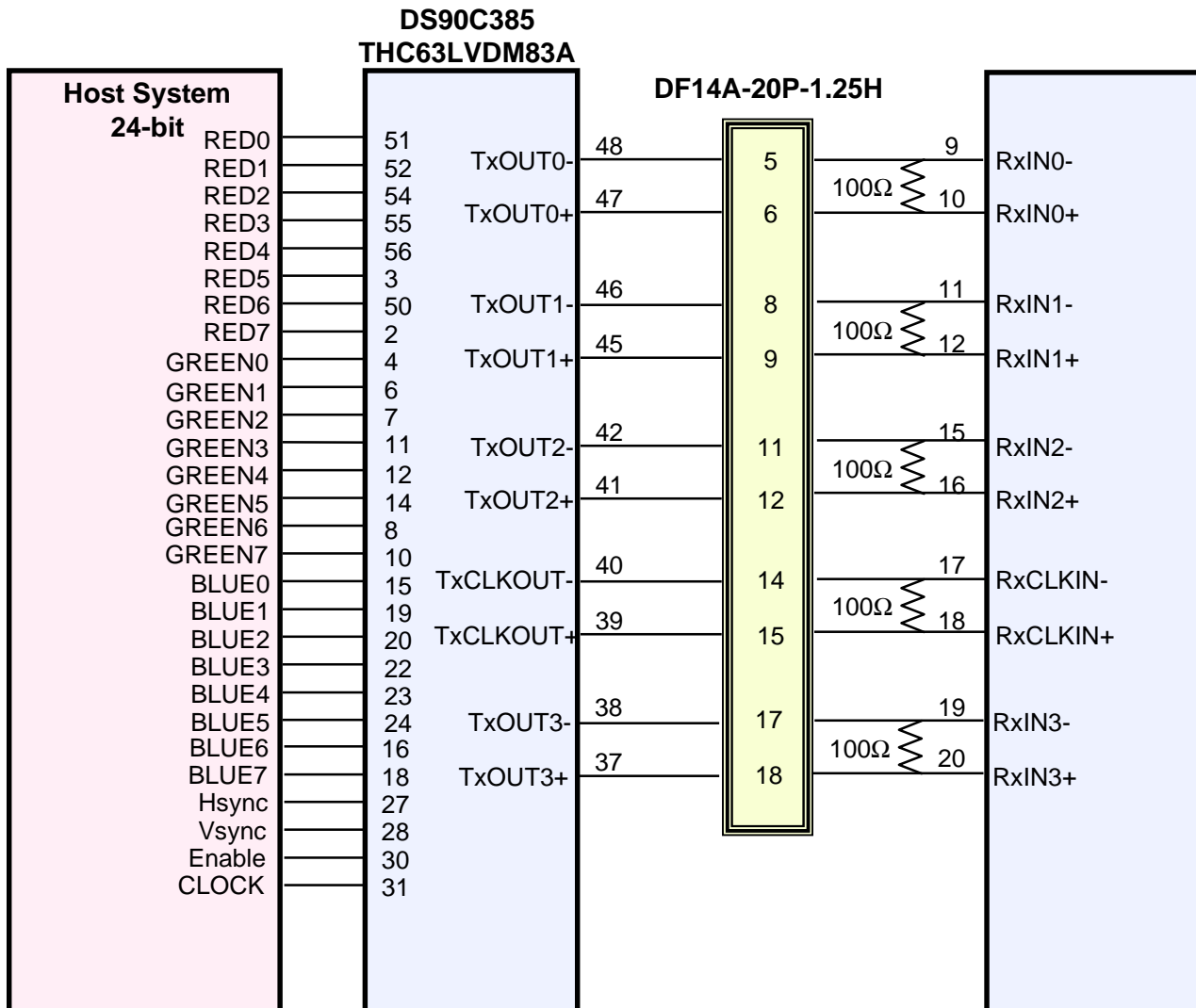

Note : The LCD Module uses a 100ohm resistor between positive and negative lines of each receiver input.

5.3 BACK-LIGHT UNIT

Connector : JST BHSR - 02VS -1
Mating Connector : SM02B-BHSS-1(JST)

Pin NO.	Symbol	Color	Function
1	HOT	Pink or Blue	High Voltage
2	COLD	White or Black	Ground

5.4 Input Signal, Basic Display Colors and Gray Scale of Each Colors

Color	Display	Data Signal																					Gray Scale Level			
		Red							Green							Blue										
		R0	R1	R2	R3	R4	R5	R6	R7	G0	G1	G2	G3	G4	G5	G6	G7	B0	B1	B2	B3	B4		B5	B6	B7
Basic Color	Black	0	0	0	0	0	0	0	0	0	0	0	0	0	0	0	0	0	0	0	0	0	0	0	0	-
	Blue	0	0	0	0	0	0	0	0	0	0	0	0	0	0	0	0	1	1	1	1	1	1	1	1	-
	Green	0	0	0	0	0	0	0	0	1	1	1	1	1	1	1	1	0	0	0	0	0	0	0	0	-
	Cyan	0	0	0	0	0	0	0	0	1	1	1	1	1	1	1	1	1	1	1	1	1	1	1	1	-
	Red	1	1	1	1	1	1	1	1	0	0	0	0	0	0	0	0	0	0	0	0	0	0	0	0	-
	Magenta	1	1	1	1	1	1	1	1	0	0	0	0	0	0	0	0	1	1	1	1	1	1	1	1	-
	Yellow	1	1	1	1	1	1	1	1	1	1	1	1	1	1	1	1	0	0	0	0	0	0	0	0	-
	White	1	1	1	1	1	1	1	1	1	1	1	1	1	1	1	1	1	1	1	1	1	1	1	1	-
Gray Scale of Red	Black	0	0	0	0	0	0	0	0	0	0	0	0	0	0	0	0	0	0	0	0	0	0	0	R000	
	Dark	1	0	0	0	0	0	0	0	0	0	0	0	0	0	0	0	0	0	0	0	0	0	0	R001	
		0	1	0	0	0	0	0	0	0	0	0	0	0	0	0	0	0	0	0	0	0	0	0	R002	
	↑	·	·	·	·	·	·	·	·	·	·	·	·	·	·	·	·	·	·	·	·	·	·	·	R003 ~ R252	
		·	·	·	·	·	·	·	·	·	·	·	·	·	·	·	·	·	·	·	·	·	·	·		
	↓	·	·	·	·	·	·	·	·	·	·	·	·	·	·	·	·	·	·	·	·	·	·	·	R252	
		·	·	·	·	·	·	·	·	·	·	·	·	·	·	·	·	·	·	·	·	·	·	·		
	Light	1	0	1	1	1	1	1	1	0	0	0	0	0	0	0	0	0	0	0	0	0	0	0	R252	
0		1	1	1	1	1	1	1	0	0	0	0	0	0	0	0	0	0	0	0	0	0	0	R252		
Red	1	1	1	1	1	1	1	1	0	0	0	0	0	0	0	0	0	0	0	0	0	0	0	R252		
Gray Scale of Green	Black	0	0	0	0	0	0	0	0	0	0	0	0	0	0	0	0	0	0	0	0	0	0	0	G000	
	Dark	0	0	0	0	0	0	0	0	1	0	0	0	0	0	0	0	0	0	0	0	0	0	0	G001	
		0	0	0	0	0	0	0	0	0	1	0	0	0	0	0	0	0	0	0	0	0	0	0	G002	
	↑	·	·	·	·	·	·	·	·	·	·	·	·	·	·	·	·	·	·	·	·	·	·	·	G003 ~ G252	
		·	·	·	·	·	·	·	·	·	·	·	·	·	·	·	·	·	·	·	·	·	·	·		
	↓	·	·	·	·	·	·	·	·	·	·	·	·	·	·	·	·	·	·	·	·	·	·	·	G252	
		·	·	·	·	·	·	·	·	·	·	·	·	·	·	·	·	·	·	·	·	·	·	·		
	Light	0	0	0	0	0	0	0	0	1	0	1	1	1	1	1	1	0	0	0	0	0	0	0	G252	
0		0	0	0	0	0	0	0	0	1	1	1	1	1	1	1	0	0	0	0	0	0	0	G252		
Green	0	0	0	0	0	0	0	0	1	1	1	1	1	1	1	1	0	0	0	0	0	0	0	G252		
Gray Scale of Blue	Black	0	0	0	0	0	0	0	0	0	0	0	0	0	0	0	0	0	0	0	0	0	0	0	B000	
	Dark	0	0	0	0	0	0	0	0	0	0	0	0	0	0	0	0	1	0	0	0	0	0	0	B001	
		0	0	0	0	0	0	0	0	0	0	0	0	0	0	0	0	0	1	0	0	0	0	0	B002	
	↑	·	·	·	·	·	·	·	·	·	·	·	·	·	·	·	·	·	·	·	·	·	·	·	B003 ~ B252	
		·	·	·	·	·	·	·	·	·	·	·	·	·	·	·	·	·	·	·	·	·	·	·		
	↓	·	·	·	·	·	·	·	·	·	·	·	·	·	·	·	·	·	·	·	·	·	·	·	B252	
		·	·	·	·	·	·	·	·	·	·	·	·	·	·	·	·	·	·	·	·	·	·	·		
	Light	0	0	0	0	0	0	0	0	0	0	0	0	0	0	0	0	1	0	1	1	1	1	1	B252	
0		0	0	0	0	0	0	0	0	0	0	0	0	0	0	0	0	1	1	1	1	1	1	B252		
Blue	0	0	0	0	0	0	0	0	0	0	0	0	0	0	0	0	1	1	1	1	1	1	1	B252		

Note) ✓ Definition of Gray :

Rn : Red Gray, Gn : Green Gray, Bn : Blue Gray (n = Gray level)

✓ Input Signal : 0 = Low level voltage, 1 = High level voltage

5.5 PIXEL FORMAT

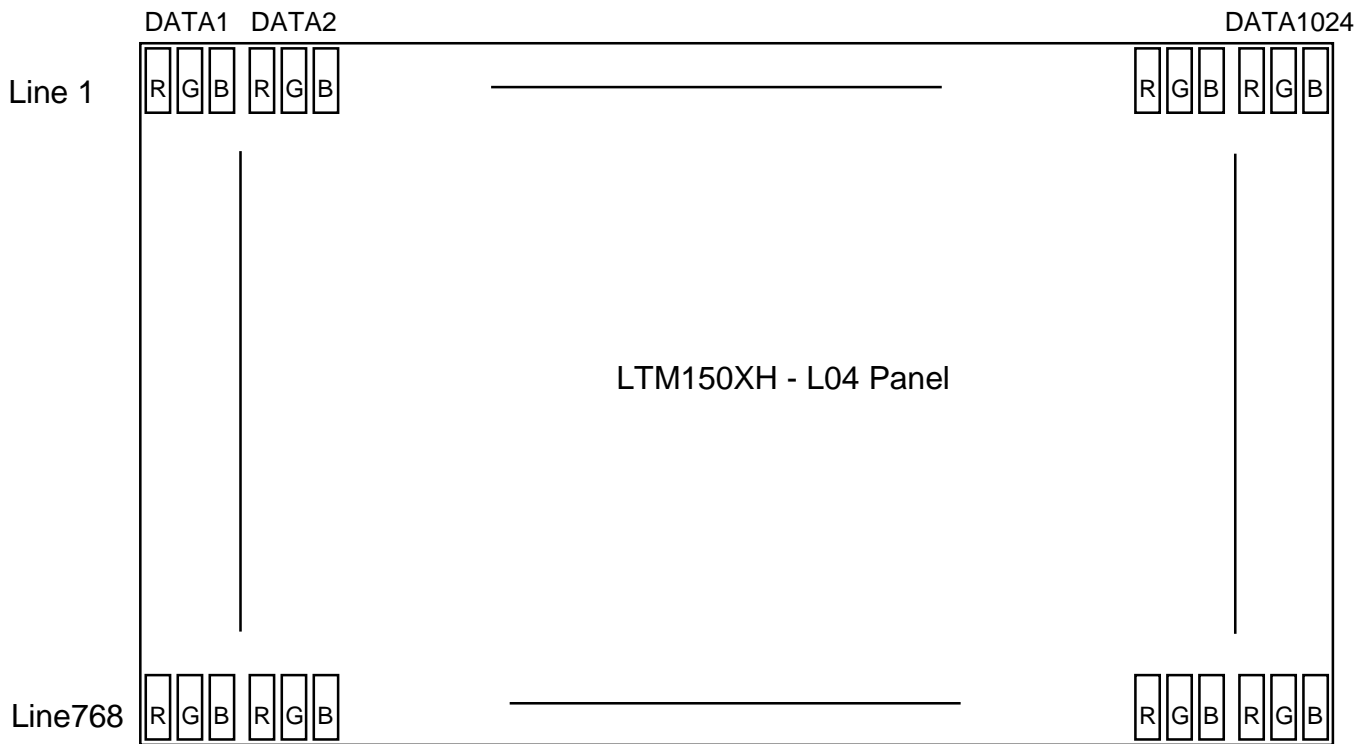

6. INTERFACE TIMING

6.1 Timing Parameters (DE only mode, LVDS Transmitter Input)

Signal	Item	Symbol	MIN	TYP	MAX	Unit	Note
Clock	Frequency	1 / Tc	47	65	80	MHz	
	High Time	TCH	4.5	-	-	nsec	
	Low Time	TCL	4.5	-	-	nsec	
Data	Setup Time	TDS	2.7	-	-	nsec	
	Hold Time	TDH	0	-	-	nsec	
Data Enable	Setup Time	TES	2.7	-	-	nsec	(1)
Frame Frequency	Cycle	TV	772	16.7 806	-	msec lines	
Vertical Active Display Term	Display Period	TVD	768	768	768	lines	
One Line Scanning Time	Cycle	TH	1100	1344	1800	clocks	
Horizontal Active Display Term	Display Period	THD	1024	1024	1024	clocks	

Note (1) When LTM150XH-L04 model is operated by DE only mode, Hsync and Vsync input signals should be fixed to "Low" for stable operation. Otherwise, the module could operate abnormally.

6.2 Timing diagrams of interface signal (DE mode)

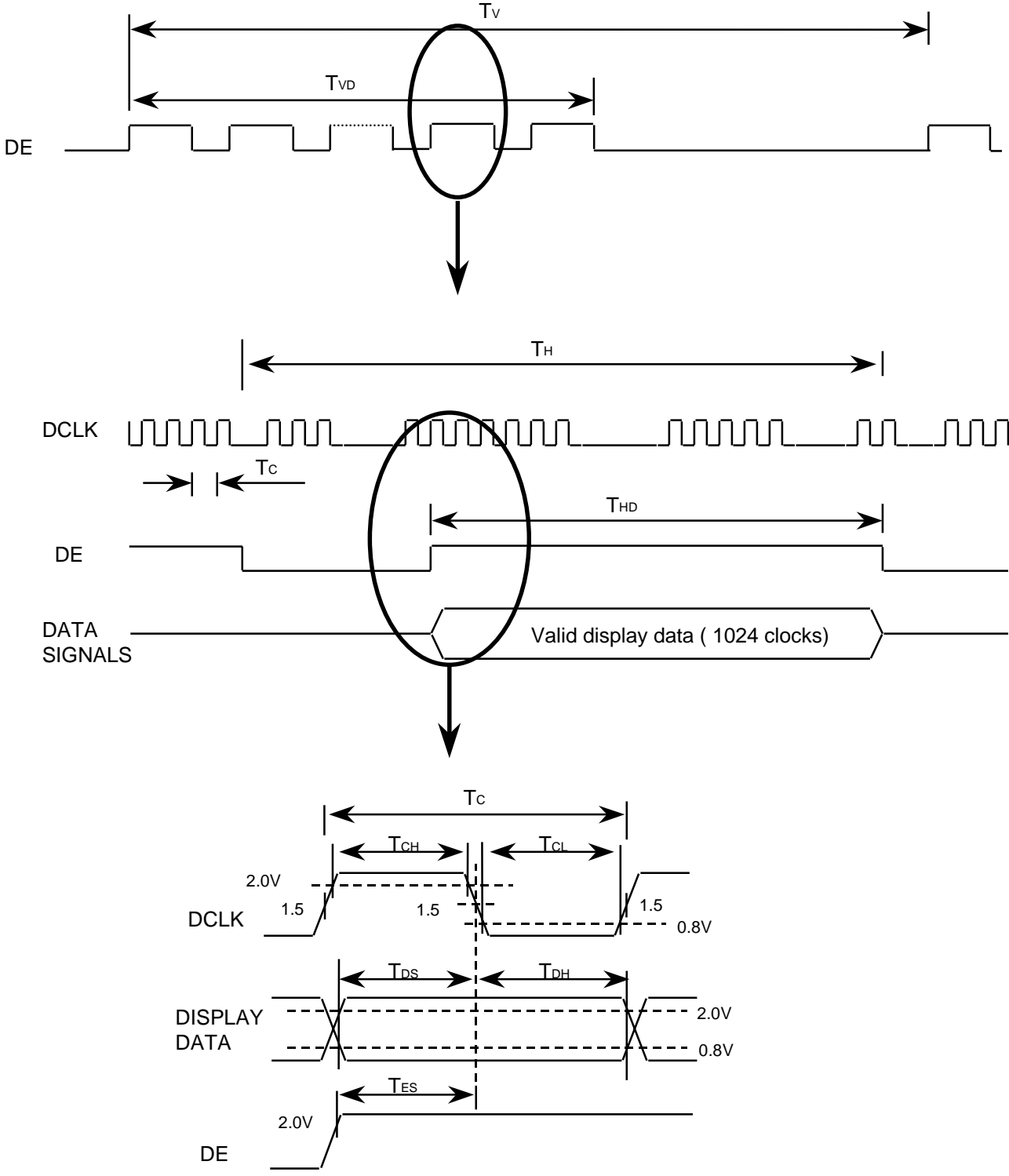

6.3 Timing Diagrams of LVDS

LVDS Transmitter : National Semiconductor DS90CF385

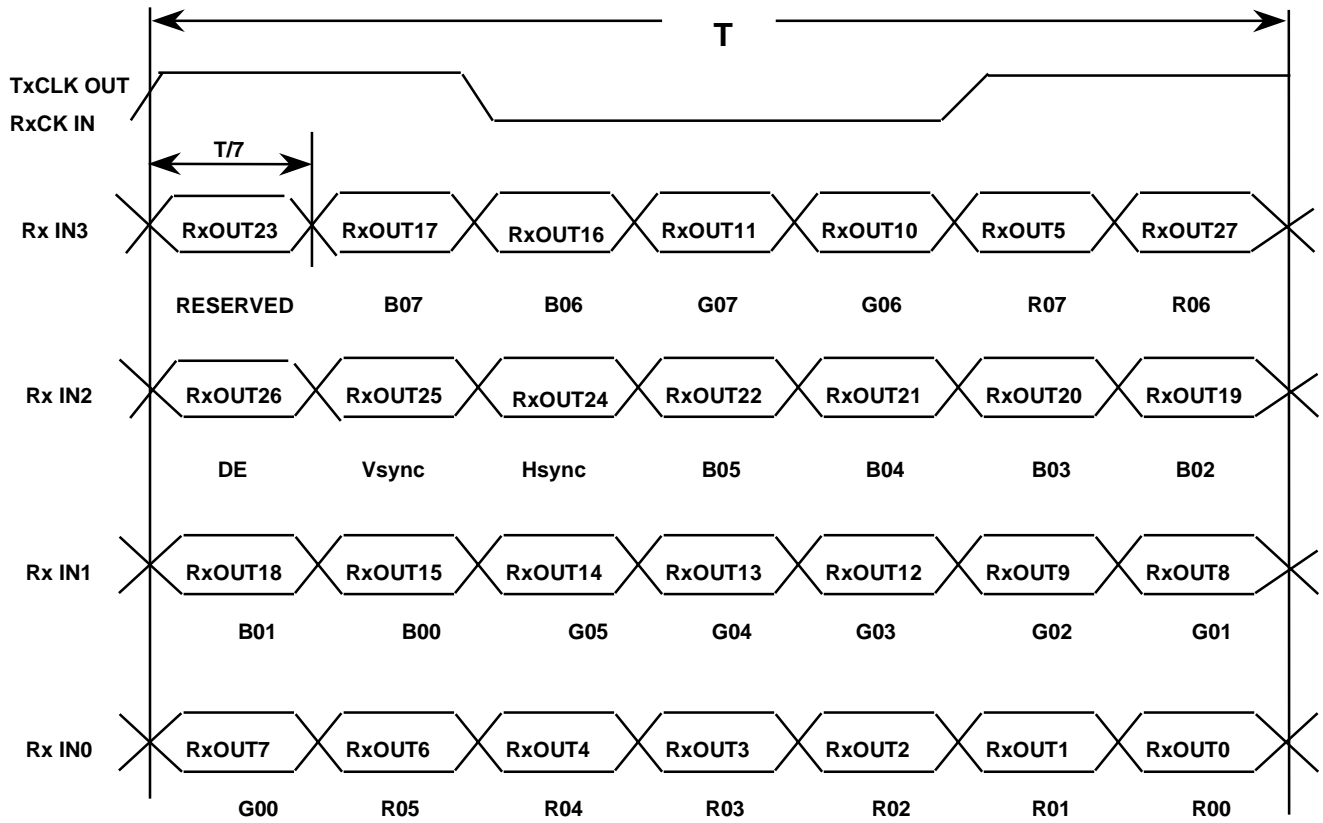

6.4 Power ON/OFF Sequence

: To prevent a latch-up or DC operation of the LCD module, the power on/off sequence should be as the diagram below.

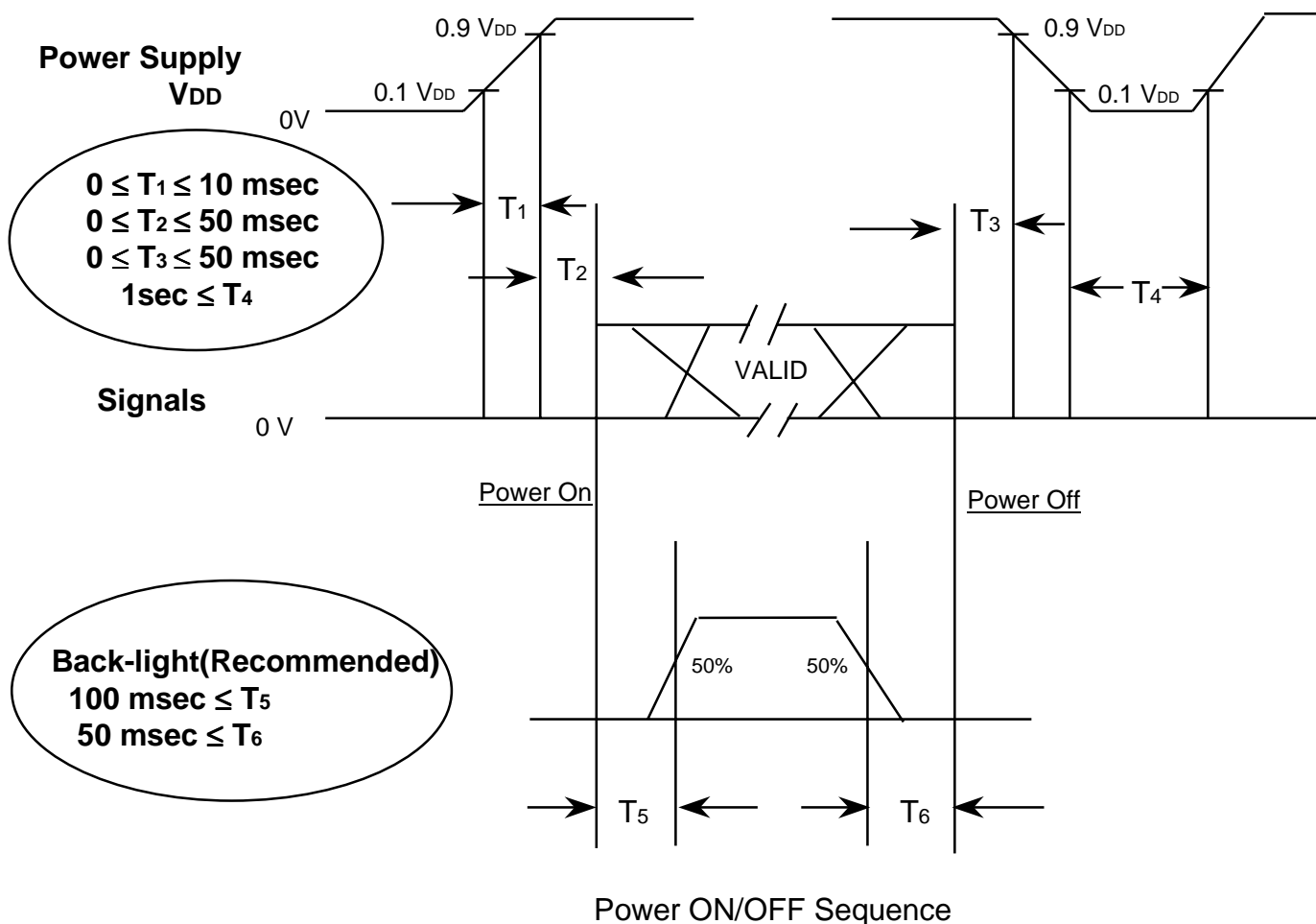

Power ON/OFF Sequence

NOTE.

- (1) The supply voltage of the external system for the module input should be the same as the definition of V_{DD}.
- (2) Apply the lamp voltage within the LCD operation range. When the back-light turns on before the LCD operation or the LCD turns off before the back-light turns off, the display may momentarily become white.
- (3) In case of V_{DD} = off level, please keep the level of input signals on the low or keep a high impedance.
- (4) T₄ should be measured after the module has been fully discharged between power off and on period.
- (5) Interface signal shall not be kept at high impedance when the power is on.

7. OUTLINE DIMENSION

Approval

[Refer to the next page]

NO.	PART NAME	CODE NO.	SPECIFICATION	QTY	REMARK

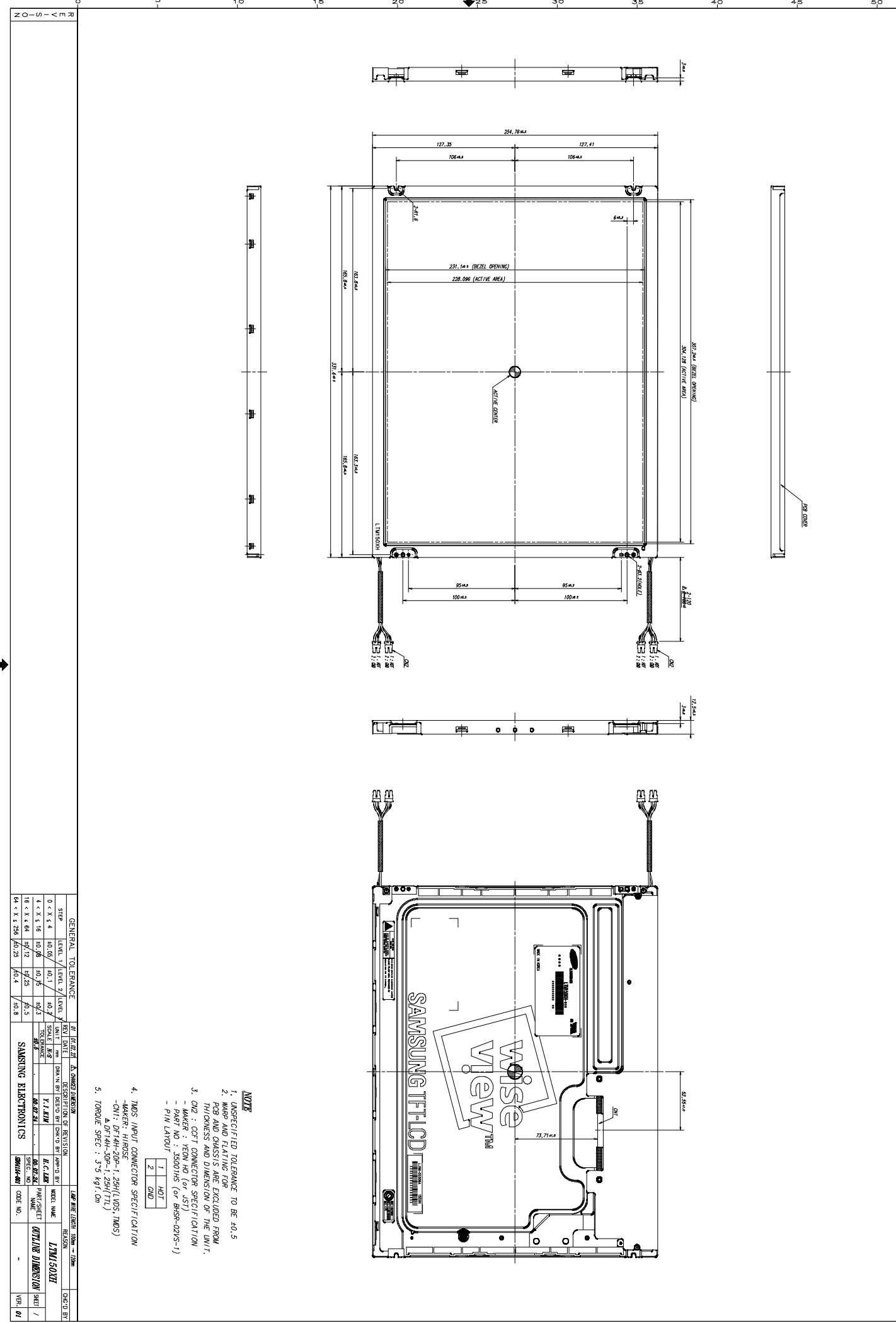

- NOTE**
- UNSPECIFIED TOLERANCE TO BE ±0.5
 - WARP AND FLATTING FOR BEZEL AND GLASS ARE EXCLUDED FROM THE DIMENSION AND DIMENSION OF THE UNIT.
 - QW : CCT CONNECTOR SPECIFICATION
 - WAFER : 7200 N0 (or US1)
 - WAFER : 12500 N0 (or US2)
 - PIN LAYOUT
 - T100S INPUT CONNECTOR SPECIFICATION
 - WAFER : 110020
 - WAFER : 12500 N0 (or US1)
 - WAFER : 12500 N0 (or US2)
 - WAFER : 12500 N0 (or US3)
 - WAFER : 12500 N0 (or US4)
 - WAFER : 12500 N0 (or US5)
 - WAFER : 12500 N0 (or US6)
 - WAFER : 12500 N0 (or US7)
 - WAFER : 12500 N0 (or US8)
 - WAFER : 12500 N0 (or US9)
 - WAFER : 12500 N0 (or US10)
 - WAFER : 12500 N0 (or US11)
 - WAFER : 12500 N0 (or US12)
 - WAFER : 12500 N0 (or US13)
 - WAFER : 12500 N0 (or US14)
 - WAFER : 12500 N0 (or US15)
 - WAFER : 12500 N0 (or US16)
 - WAFER : 12500 N0 (or US17)
 - WAFER : 12500 N0 (or US18)
 - WAFER : 12500 N0 (or US19)
 - WAFER : 12500 N0 (or US20)
 - WAFER : 12500 N0 (or US21)
 - WAFER : 12500 N0 (or US22)
 - WAFER : 12500 N0 (or US23)
 - WAFER : 12500 N0 (or US24)
 - WAFER : 12500 N0 (or US25)
 - WAFER : 12500 N0 (or US26)
 - WAFER : 12500 N0 (or US27)
 - WAFER : 12500 N0 (or US28)
 - WAFER : 12500 N0 (or US29)
 - WAFER : 12500 N0 (or US30)
 - WAFER : 12500 N0 (or US31)
 - WAFER : 12500 N0 (or US32)
 - WAFER : 12500 N0 (or US33)
 - WAFER : 12500 N0 (or US34)
 - WAFER : 12500 N0 (or US35)
 - WAFER : 12500 N0 (or US36)
 - WAFER : 12500 N0 (or US37)
 - WAFER : 12500 N0 (or US38)
 - WAFER : 12500 N0 (or US39)
 - WAFER : 12500 N0 (or US40)
 - WAFER : 12500 N0 (or US41)
 - WAFER : 12500 N0 (or US42)
 - WAFER : 12500 N0 (or US43)
 - WAFER : 12500 N0 (or US44)
 - WAFER : 12500 N0 (or US45)
 - WAFER : 12500 N0 (or US46)
 - WAFER : 12500 N0 (or US47)
 - WAFER : 12500 N0 (or US48)
 - WAFER : 12500 N0 (or US49)
 - WAFER : 12500 N0 (or US50)
 - WAFER : 12500 N0 (or US51)
 - WAFER : 12500 N0 (or US52)
 - WAFER : 12500 N0 (or US53)
 - WAFER : 12500 N0 (or US54)
 - WAFER : 12500 N0 (or US55)
 - WAFER : 12500 N0 (or US56)
 - WAFER : 12500 N0 (or US57)
 - WAFER : 12500 N0 (or US58)
 - WAFER : 12500 N0 (or US59)
 - WAFER : 12500 N0 (or US60)
 - WAFER : 12500 N0 (or US61)
 - WAFER : 12500 N0 (or US62)
 - WAFER : 12500 N0 (or US63)
 - WAFER : 12500 N0 (or US64)
 - WAFER : 12500 N0 (or US65)
 - WAFER : 12500 N0 (or US66)
 - WAFER : 12500 N0 (or US67)
 - WAFER : 12500 N0 (or US68)
 - WAFER : 12500 N0 (or US69)
 - WAFER : 12500 N0 (or US70)
 - WAFER : 12500 N0 (or US71)
 - WAFER : 12500 N0 (or US72)
 - WAFER : 12500 N0 (or US73)
 - WAFER : 12500 N0 (or US74)
 - WAFER : 12500 N0 (or US75)
 - WAFER : 12500 N0 (or US76)
 - WAFER : 12500 N0 (or US77)
 - WAFER : 12500 N0 (or US78)
 - WAFER : 12500 N0 (or US79)
 - WAFER : 12500 N0 (or US80)
 - WAFER : 12500 N0 (or US81)
 - WAFER : 12500 N0 (or US82)
 - WAFER : 12500 N0 (or US83)
 - WAFER : 12500 N0 (or US84)
 - WAFER : 12500 N0 (or US85)
 - WAFER : 12500 N0 (or US86)
 - WAFER : 12500 N0 (or US87)
 - WAFER : 12500 N0 (or US88)
 - WAFER : 12500 N0 (or US89)
 - WAFER : 12500 N0 (or US90)
 - WAFER : 12500 N0 (or US91)
 - WAFER : 12500 N0 (or US92)
 - WAFER : 12500 N0 (or US93)
 - WAFER : 12500 N0 (or US94)
 - WAFER : 12500 N0 (or US95)
 - WAFER : 12500 N0 (or US96)
 - WAFER : 12500 N0 (or US97)
 - WAFER : 12500 N0 (or US98)
 - WAFER : 12500 N0 (or US99)
 - WAFER : 12500 N0 (or US100)
 - WAFER : 12500 N0 (or US101)
 - WAFER : 12500 N0 (or US102)
 - WAFER : 12500 N0 (or US103)
 - WAFER : 12500 N0 (or US104)
 - WAFER : 12500 N0 (or US105)
 - WAFER : 12500 N0 (or US106)
 - WAFER : 12500 N0 (or US107)
 - WAFER : 12500 N0 (or US108)
 - WAFER : 12500 N0 (or US109)
 - WAFER : 12500 N0 (or US110)
 - WAFER : 12500 N0 (or US111)
 - WAFER : 12500 N0 (or US112)
 - WAFER : 12500 N0 (or US113)
 - WAFER : 12500 N0 (or US114)
 - WAFER : 12500 N0 (or US115)
 - WAFER : 12500 N0 (or US116)
 - WAFER : 12500 N0 (or US117)
 - WAFER : 12500 N0 (or US118)
 - WAFER : 12500 N0 (or US119)
 - WAFER : 12500 N0 (or US120)
 - WAFER : 12500 N0 (or US121)
 - WAFER : 12500 N0 (or US122)
 - WAFER : 12500 N0 (or US123)
 - WAFER : 12500 N0 (or US124)
 - WAFER : 12500 N0 (or US125)
 - WAFER : 12500 N0 (or US126)
 - WAFER : 12500 N0 (or US127)
 - WAFER : 12500 N0 (or US128)
 - WAFER : 12500 N0 (or US129)
 - WAFER : 12500 N0 (or US130)
 - WAFER : 12500 N0 (or US131)
 - WAFER : 12500 N0 (or US132)
 - WAFER : 12500 N0 (or US133)
 - WAFER : 12500 N0 (or US134)
 - WAFER : 12500 N0 (or US135)
 - WAFER : 12500 N0 (or US136)
 - WAFER : 12500 N0 (or US137)
 - WAFER : 12500 N0 (or US138)
 - WAFER : 12500 N0 (or US139)
 - WAFER : 12500 N0 (or US140)
 - WAFER : 12500 N0 (or US141)
 - WAFER : 12500 N0 (or US142)
 - WAFER : 12500 N0 (or US143)
 - WAFER : 12500 N0 (or US144)
 - WAFER : 12500 N0 (or US145)
 - WAFER : 12500 N0 (or US146)
 - WAFER : 12500 N0 (or US147)
 - WAFER : 12500 N0 (or US148)
 - WAFER : 12500 N0 (or US149)
 - WAFER : 12500 N0 (or US150)
 - WAFER : 12500 N0 (or US151)
 - WAFER : 12500 N0 (or US152)
 - WAFER : 12500 N0 (or US153)
 - WAFER : 12500 N0 (or US154)
 - WAFER : 12500 N0 (or US155)
 - WAFER : 12500 N0 (or US156)
 - WAFER : 12500 N0 (or US157)
 - WAFER : 12500 N0 (or US158)
 - WAFER : 12500 N0 (or US159)
 - WAFER : 12500 N0 (or US160)
 - WAFER : 12500 N0 (or US161)
 - WAFER : 12500 N0 (or US162)
 - WAFER : 12500 N0 (or US163)
 - WAFER : 12500 N0 (or US164)
 - WAFER : 12500 N0 (or US165)
 - WAFER : 12500 N0 (or US166)
 - WAFER : 12500 N0 (or US167)
 - WAFER : 12500 N0 (or US168)
 - WAFER : 12500 N0 (or US169)
 - WAFER : 12500 N0 (or US170)
 - WAFER : 12500 N0 (or US171)
 - WAFER : 12500 N0 (or US172)
 - WAFER : 12500 N0 (or US173)
 - WAFER : 12500 N0 (or US174)
 - WAFER : 12500 N0 (or US175)
 - WAFER : 12500 N0 (or US176)
 - WAFER : 12500 N0 (or US177)
 - WAFER : 12500 N0 (or US178)
 - WAFER : 12500 N0 (or US179)
 - WAFER : 12500 N0 (or US180)
 - WAFER : 12500 N0 (or US181)
 - WAFER : 12500 N0 (or US182)
 - WAFER : 12500 N0 (or US183)
 - WAFER : 12500 N0 (or US184)
 - WAFER : 12500 N0 (or US185)
 - WAFER : 12500 N0 (or US186)
 - WAFER : 12500 N0 (or US187)
 - WAFER : 12500 N0 (or US188)
 - WAFER : 12500 N0 (or US189)
 - WAFER : 12500 N0 (or US190)
 - WAFER : 12500 N0 (or US191)
 - WAFER : 12500 N0 (or US192)
 - WAFER : 12500 N0 (or US193)
 - WAFER : 12500 N0 (or US194)
 - WAFER : 12500 N0 (or US195)
 - WAFER : 12500 N0 (or US196)
 - WAFER : 12500 N0 (or US197)
 - WAFER : 12500 N0 (or US198)
 - WAFER : 12500 N0 (or US199)
 - WAFER : 12500 N0 (or US200)
 - TORQUE SPEC : 3~5 kgf.cm

GENERAL TOLERANCE		REF. DIM.		DELTA DIMENSION OR RESOLUTION		LAYER THICKNESS		REASON		CHECK BY	
STEP	LEVEL 1 / LEVEL 2 / LEVEL 3	LEVEL 1 / LEVEL 2 / LEVEL 3	SCALE	UNIT	UNIT	UNIT	UNIT	MODEL NAME	DATE	DATE	DATE
0 < X < 4	±0.05 / ±0.1	±0.1	±0.3	±0.3	±0.3	±0.3	±0.3	T100S00H	1/15/2011	1/15/2011	1/15/2011
4 < X < 16	±0.05	±0.05	±0.3	±0.3	±0.3	±0.3	±0.3	T100S00H	1/15/2011	1/15/2011	1/15/2011
16 < X < 64	±0.12	±0.25	±0.5	±0.5	±0.5	±0.5	±0.5	T100S00H	1/15/2011	1/15/2011	1/15/2011
64 < X < 256	±0.25	±0.5	±1.0	±1.0	±1.0	±1.0	±1.0	T100S00H	1/15/2011	1/15/2011	1/15/2011

SAMSUNG ELECTRONICS		LAYER THICKNESS		REASON		CHECK BY	
STEP	LEVEL 1 / LEVEL 2 / LEVEL 3	SCALE	UNIT	MODEL NAME	DATE	DATE	DATE
0 < X < 4	±0.05 / ±0.1	±0.3	±0.3	T100S00H	1/15/2011	1/15/2011	1/15/2011
4 < X < 16	±0.05	±0.05	±0.3	T100S00H	1/15/2011	1/15/2011	1/15/2011
16 < X < 64	±0.12	±0.25	±0.5	T100S00H	1/15/2011	1/15/2011	1/15/2011
64 < X < 256	±0.25	±0.5	±1.0	T100S00H	1/15/2011	1/15/2011	1/15/2011

8. RELIABILITY TEST

Test Items	Conditions	Time / Cycle	Sample
HTOL*	50°C, Dynamic	250 hrs	12
LTOL*	0 °C, Dynamic	250 hrs	5
THB*	40°C / 90%, Dynamic	250 hrs	5
HTS****	70°C, No Bias	250 hrs	5
LTS****	-30°C, No Bias	250 hrs	5
Thermal Shock (Non-operating)	-20 ~ 60°C, No bias, Ramp-up & down : 1 min., Soak time : 30min.	100 Cyc.	5
Temperature Characteristics & Power on/off	Storage : 0°C, 30min., 10 times (power on/off) Ramp up : 0~ 25°C, 30 min Storage : 25°C, 30 min., 10 times (power on/off) Ramp up : 20~ 50°C, 30 min. Storage : 50°C, 30 min., 10 times (power on/off) Ramp up : 50~ 0°C, 30 min.	10Cyc.	10
Shock (Non-operating)	50 G, 11 msec, Sine wave, ± x/y/z axis	one time/axis	3
Vibration (Non-operating)	1.5G, 10 ~ 300 ~ 10 Hz, x/y/z axis, sweep rate : 10 min.	30 min/axis	3
ESD (Non-operating)	Contact : 150pF, 330 ohm Air : 150pF, 330 ohm	± 10KV ± 20KV	3 3
Box Vibration	1.1G, 5 ~ 100Hz, 1hour / y axis(up/down), sweep rate : 5min		10
Box Drop	Height : 66cm		10

[Result Evaluation Criteria]

Under the display quality test conditions with normal operation state, these shall be no change which may affect practical display function.

* HTOL/ LTOL : High/Low Temperature Operating Life, ** THB : Temperature Humidity Bias

**** HTS/LTS : High/Low Temperature Storage

9. PACKING

9.1 CARTON(Internal Packing)

(1) Packing Form

Corrugated fiberboard box and corrugated foam as shock absorber

(2) Packing Method

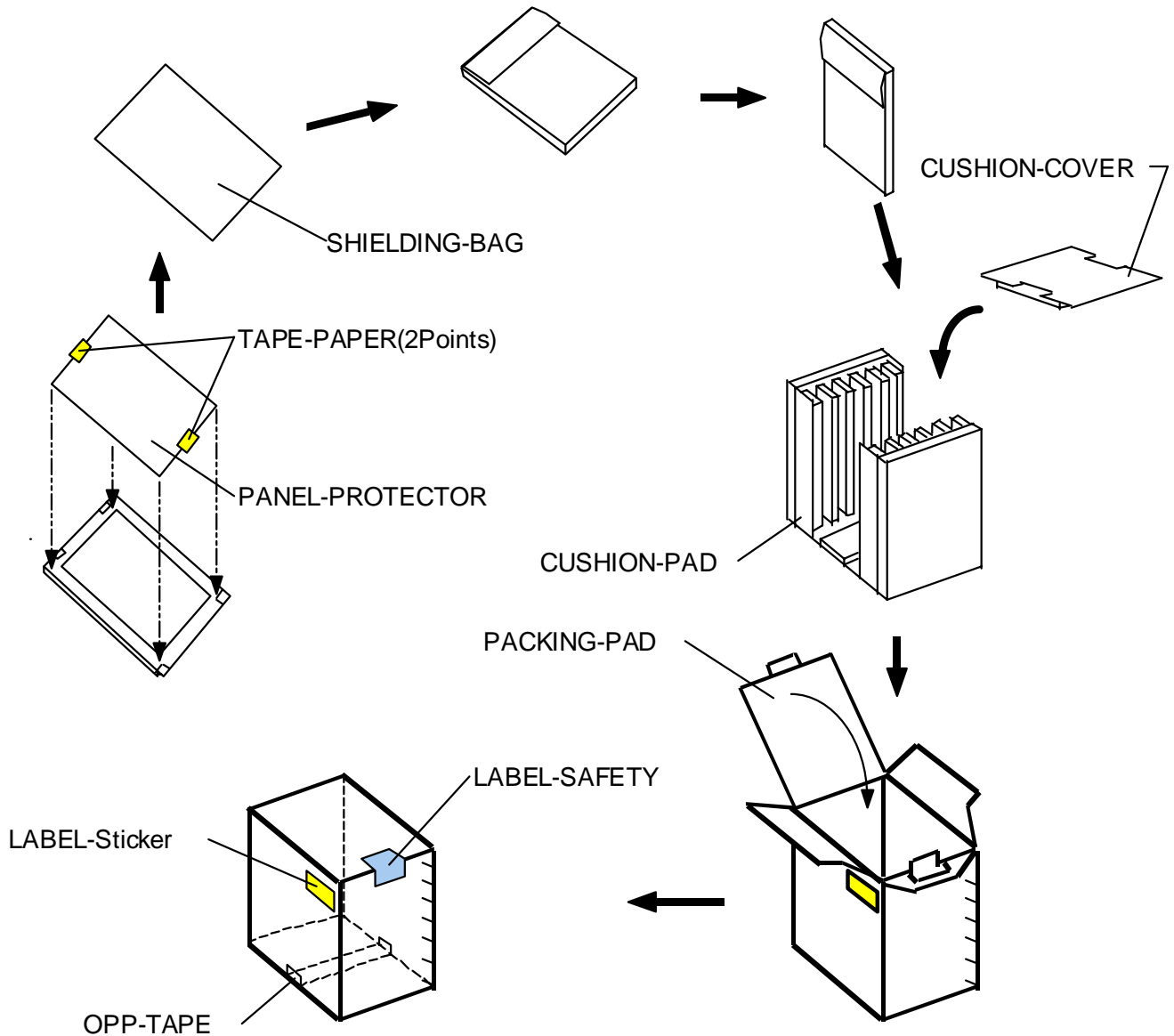

Note (1) Total : Approx. 13.0 Kg

(2) Acceptance number of piling : 10 sets

(3) Carton size : 450 (W) X 348 (D) X 440 (H)

(4) Max accumulation quantity : 7 cartons

(3) Packing Material

No	Part name	Quantity	No	Part name	Quantity
1	PROTECTOR-PANEL	1	6	SHIELDING-BAG	1
2	TAPE-PAPER	0.06MT	7	OPP-TAPE	0.2MT
3	PACKING-CASE	0.1	8	LABEL-STICKER	1
4	CUSHION-PAD	0.1	9	LABEL-SAFETY	1
5	CUSHION-COVER	0.1			

10. MARKING & OTHERS

A nameplate bearing followed by is affixed to a shipped product at the specified location on each product.

(1)Parts number : LTM150XH-L04

(2)Revision : One letter

(3)Control Code : One letter

(4)Lot number : 4 K 0 H 123 01 01

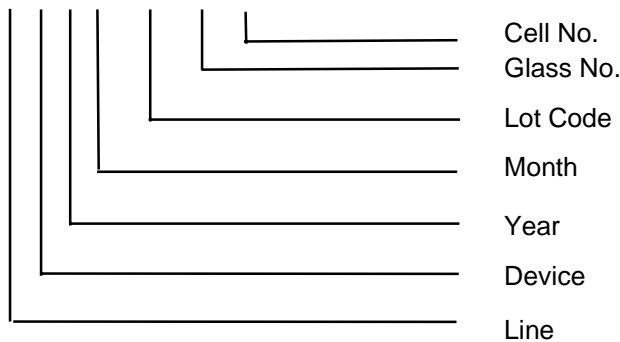

(5) Nameplate Indication

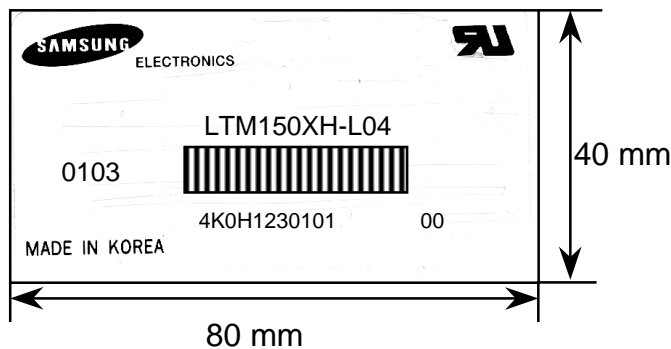

Parts name : LTM150XH-L04
 Lot number : 4K0H1230101
 Inspected work week : 0103

■ High voltage caution

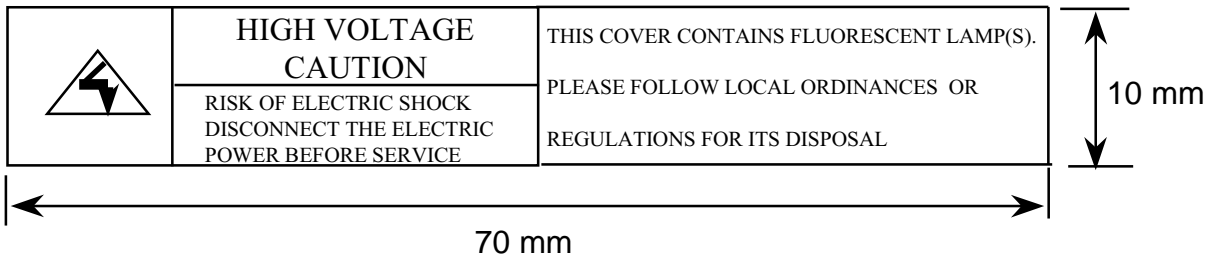

(6) Packing box attach

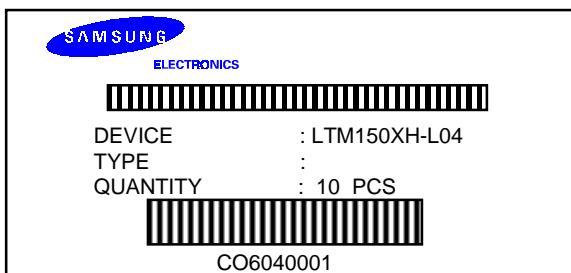

11. General Precautions

11.1 Handling

- (a) When the module is assembled, It should be attached to the system firmly using every mounting holes. Be careful not to twist and bend the modules.
- (b) Refrain from strong mechanical shock and / or any force to the module. In addition to damage, this may cause improper operation or damage to the module and CCFT back-light.
- (c) Note that polarizers are very fragile and could be easily damaged. Do not press or scratch the surface harder than a HB pencil lead.
- (d) Wipe off water droplets or oil immediately. If you leave the droplets for a long time, Staining and discoloration may occur.
- (e) If the surface of the polarizer is dirty, clean it using some absorbent cotton or soft cloth.
- (f) The desirable cleaners are water, IPA(Isopropyl Alcohol) or Hexane. Do not use Ketone type materials(ex. Acetone), Ethyl alcohol, Toluene, Ethyl acid or Methyl chloride. It might permanent damage to the polarizer due to chemical reaction.
- (g) If the liquid crystal material leaks from the panel, it should be kept away from the eyes or mouth. In case of contact with hands, legs or clothes, it must be washed away thoroughly with soap.
- (h) Protect the module from static, it may cause damage to the C-MOS Gate Array IC.
- (i) Use finger-stalls with soft gloves in order to keep display clean during the incoming inspection and assembly process.
- (j) Do not disassemble the module.
- (k) Do not pull or fold the lamp wire.
- (l) Do not adjust the variable resistor which is located on the back side.
- (m) Pins of I/F connector shall not be touched directly with bare hands.

11.2 Storage

- (a) Do not leave the module in high temperature, and high humidity for a long time.
It is highly recommended to store the module with temperature from 0 to 35 °C and relative humidity of less than 70%.
- (b) Do not store the TFT-LCD module in direct sunlight.
- (c) The module shall be stored in a dark place. It is prohibited to apply sunlight or fluorescent light during the store.

11.3. Operation

- (a) Do not connect, disconnect the module in the “ Power On” condition.
- (b) Power supply should always be turned on/off by following item 6.6 “ Power on/off sequence “.
- (c) Module has high frequency circuits. Sufficient suppression to the electromagnetic interference shall be done by system manufacturers. Grounding and shielding methods may be important to minimize the interference.
- (d) The cable between the back-light connector and its inverter power supply shall be a minimized length and be connected directly . The longer cable between the back-light and the inverter may cause lower luminance of lamp(CCFT) and may require higher startup voltage(Vs).

11.4 Others

- (a) Ultra-violet ray filter is necessary for outdoor operation.
- (b) Avoid condensation of water. It may result in improper operation or disconnection of electrode.
- (c) Do not exceed the absolute maximum rating value. (the supply voltage variation, input voltage variation, variation in part contents and environmental temperature, so on)
Otherwise the module may be damaged.
- (d) If the module displays the same pattern continuously for a long period of time, it can be the situation when the image “sticks” to the screen.
- (e) This module has its circuitry PCB's on the rear side and should be handled carefully in order not to be stressed.