



ELECTRONICS

Approval

TO :

DATE :

**SAMSUNG TFT-LCD**  
**MODEL NO. : LTM150XH-T01**

APPROVED BY :

\_\_\_\_\_  
\_\_\_\_\_  
\_\_\_\_\_  
\_\_\_\_\_

Any Modification of Spec is not allowed without SEC's permission.

Approved by : 

PREPARED BY : AMLCD Technical Customer Service Team

**SAMSUNG ELECTRONICS CO., LTD.**

## CONTENTS

Revision History	----- ( 3 )
General Description	----- ( 4 )
1. Absolute Maximum Ratings	----- ( 5 )
1.1 Absolute Ratings Of Environment	
1.2 Electrical Absolute Ratings	
2. Optical Characteristics	----- ( 7 )
3. Electrical Characteristics	----- ( 10 )
3.1 TFT LCD Module	
3.2 Back-light Unit	
4. Block Diagram	----- ( 13 )
4.1 TFT LCD Module	
4.2 Back-light Unit	
5. Input Terminal Pin Assignment	----- ( 14 )
5.1 Input Signal & Power	
5.2 Back-light Unit	
5.3 Input Signals, Basic Display Colors and Gray Scale of Each Color	
5.4 Pixel format	
6. Interface Timing	----- ( 18 )
6.1 Timing Parameters ( DE only mode)	
6.2 Timing Diagrams of interface Signal ( DE only mode)	
6.3 Power ON/OFF Sequence	
7. Outline Dimension	----- ( 21 )
8. Reliability Test	----- ( 23 )
9. Packing	----- ( 24 )
10. Marking & Others	----- ( 25 )
11. General Precaution	----- ( 27 )
# Appendix Cosmetic Outgoing Inspection Specification	----- ( 29 )

**Revision History**

Approval

Date	Rev.No.	Page	Summary
May 25, 2001	000		Approval spec of LTM150XH -T01 model is issued for the first time.

**Doc.No.**

LTM150XH-T01

**Rev.No**

04 - 000 - G - 010525

**Page**

3 /35

## GENERAL DESCRIPTION

### DESCRIPTION

LTM150XH-T01 is a color active matrix TFT (Thin Film Transistor) liquid crystal display that uses amorphous silicon TFT switching devices. This model is composed of a TFT LCD panel, a driver circuit and a back-light system. The resolution of 15.0-inch contains 1,024 x 768 pixels and can display up to 16.2M colors. 6 o'clock direction is the optimum viewing angle.

### FEATURES

- High contrast ratio, High aperture structure
- Wide viewing angle
- High-speed response
- XGA(1024x768 pixels) resolution
- Low power consumption
- 4 CCFTs (Cold Cathode Fluorescent Tube)
- DE Only Mode
- TTL Interface with 1 pixel / clock

### APPLICATIONS

- Desktop monitors
- Display terminals for AV application products
- Monitors for Industrial machine

### GENERAL SPECIFICATIONS

ITEM	SPECIFICATION	UNIT	NOTE
Active area	304.1(H) x228.1(V) (15.0 inch diagonal )	mm	
Driver element	a-Si TFT active matrix		
Display colors	262,144		
Number of pixel	1024 x 768	pixel	
Pixel arrangement	RGB vertical stripe		
Pixel pitch	0.297(H) x 0.297(W)	mm	
Display Mode	Normally white		
Surface treatment	Haze 25 , Anti-glare & Hard - Coating (3H)		

**Mechanical Information**

ITEM		MIN.	TYP.	MAX.	NOTE
Module size	Horizontal (H)	331.1	331.6	332.1	mm
	Vertical (V)	254.4	254.9	255.4	mm
	Depth (D)	-	12.5	13.0	mm
Weight		-	-	1350	g

**1. ABSOLUTE MAXIMUM RATINGS****1.1 ABSOLUTE RATINGS OF ENVIRONMENT**

ITEM	SYMBOL	MIN.	MAX.	UNIT	NOTE
Storage temperature	$T_{STG}$	-20	60	°C	(1),(5)
Operating temperature (Surface of Glass)	$T_{OPR}$	0	50	°C	(1),(5)
Shock ( non-operating )	Snop	-	50	G	(2),(4)
Vibration (non-operating)	Vnop	-	1.5	G	(3),(4)

Note (1) Temperature and relative humidity range are shown in the figure below.

90 % RH Max. (  $40\text{ }^{\circ}\text{C} \geq T_a$  )

Maximum wet - bulb temperature at  $39\text{ }^{\circ}\text{C}$  or less. ( $T_a > 40\text{ }^{\circ}\text{C}$ ) No condensation.

(2) 11ms, sine wave, 1 time for  $\pm X, \pm Y, \pm Z$ .

(3) 10 - 300 - 10 Hz, Sweep rate: 10 min, 30 min for X,Y,Z.

(4) At testing Vibration and Shock, the fixture in holding the Module to be tested have to be hard and rigid enough so that the Module would not be twisted or bent by the fixture.

(5) If product is used for extended time excessively or exposed to high temperatures for extended time, there is a possibility of wide viewing angle film damage which could affect visual characteristics.

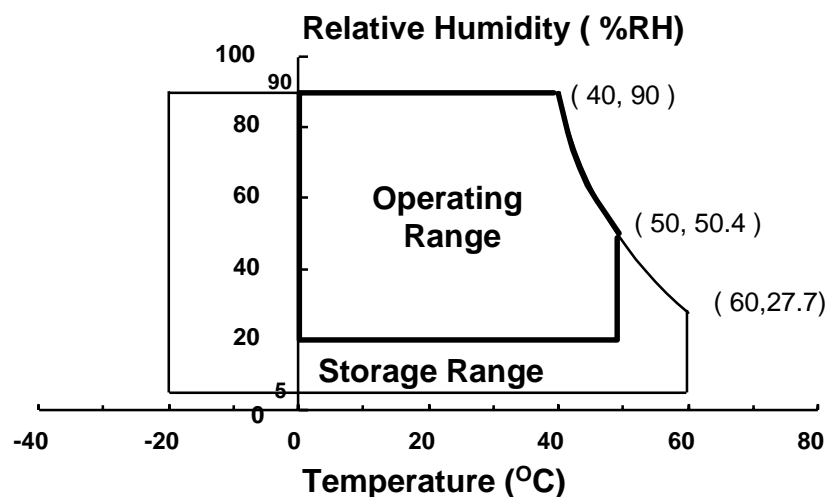

## 1.2 ELECTRICAL ABSOLUTE RATINGS

## (1) TFT LCD MODULE

(V<sub>SS</sub> = GND = 0 V)

ITEM	SYMBOL	MIN.	MAX.	UNIT	NOTE
Power Supply Voltage	VDD	GND-0.3	3.6	V	(1)

NOTE (1) With Ta ( 25 ± 2 °C )

## (2) BACK-LIGHT UNIT

Ta = 25 ± 2 °C

ITEM	SYMBOL	MIN.	MAX.	UNIT.	NOTE
Lamp current	IL	3.0	6.5	mArms	(1)
Lamp frequency	fL	40	80	KHz	(1)

NOTE (1) Permanent damage to the device may occur if maximum values are exceeded.  
Functional operation should be restricted to the conditions described under Normal Operating Conditions.

## 2. OPTICAL CHARACTERISTICS

The following items are measured under stable conditions. The optical characteristics should be measured in a dark room or equivalent state with the methods shown in Note (4).

Measuring equipment : TOPCON BM-5A

\* Ta = 25 ± 2 °C , V<sub>DD</sub> = 3.3V, fv= 60Hz, fdCLK=65MHz, IL = 6.0 mArms

ITEM		SYMBOL	CONDITION	MIN.	TYP.	MAX.	UNIT	NOTE	
Contrast Ratio (Center of screen)		CR	$\phi = 0,$ $\theta = 0$ Normal Viewing Angle	200	300	-		(1), (2), (4)	
Response Time at Ta	Rising	T <sub>R</sub>		-	5	10	msec	(1), (3)	
	Falling	T <sub>F</sub>		-	20	25			
Luminance of White ( Center of screen)		Y <sub>L</sub>			200	250	-	cd/m <sup>2</sup>	(1), (4)
Color Chromaticity ( CIE 1931 )	Red	R <sub>X</sub>			0.598	0.628	0.658		
		R <sub>Y</sub>			0.323	0.353	0.383		
	Green	G <sub>X</sub>			0.260	0.290	0.320		
		G <sub>Y</sub>			0.565	0.595	0.625		
	Blue	B <sub>X</sub>			0.114	0.144	0.174		
		B <sub>Y</sub>			0.058	0.088	0.118		
	White	W <sub>X</sub>		0.274	0.304	0.334			
		W <sub>Y</sub>		0.295	0.325	0.355			
Viewing Angle	Hor.	$\theta_L$	CR ≥ 5	65	70	-	Degrees		
		$\theta_R$		65	70	-			
	Ver.	$\phi_H$		50	55	-			
		$\phi_L$		55	60	-			
Brightness Uniformity		B <sub>UNI</sub>		-	-	20	%	(5)	



Note 4) After stabilizing and leaving the panel alone at a given temperature for 30 min , the measurement should be executed. Measurement should be executed in a stable, windless, and dark room. 30 min after lighting the back-light. This should be measured in the center of screen.  
 Lamp current : 6.0mA , Environment condition : Ta = 25 ± 2 °C

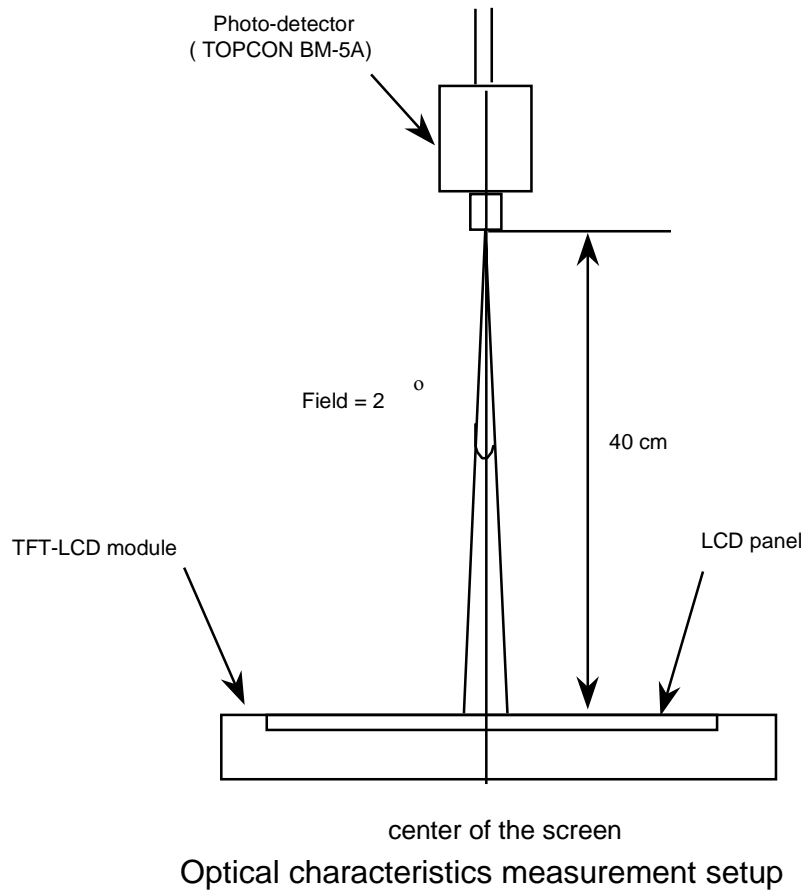

Note 5) Definition of 9 points brightness uniformity

$$B_{UNI} = \frac{|B_{max \text{ or } B_{min}} - B_{ave}|}{B_{ave}} \times 100$$

Bmax : Maximum Brightness

Bmin : Minimum Brightness

$$B_{ave} : \text{Average Brightness} = \frac{\sum_{k=1}^9 (B(k))}{9}$$

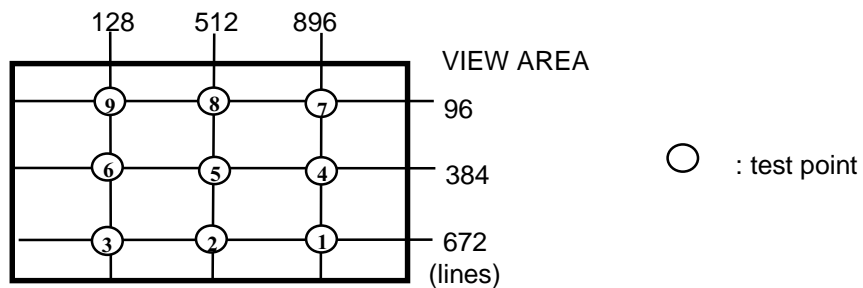

### 3. ELECTRICAL CHARACTERISTICS

#### 3.1 TFT LCD MODULE

 $T_a = 25 \pm 2 \text{ }^\circ\text{C}$ 

ITEM	SYMBOL	MIN	TYP	MAX	UNIT	NOTE	
Voltage of Power Supply	$V_{DD}$	3.0	3.3	3.6	V		
Input Voltage	High	$V_{IH}$	2.64	-	$V_{DD}$	(1)	
	Low	$V_{IL}$	GND	-	0.6		V
Current of Power Supply	White	$I_{DD}$	-	390	-	mA	(2)(4)*a
	Mosaic		-	430	-	mA	(2)(4)*b
	Sub-pixel checker		-	480	580	mA	(2)(4)*c
Vsync Frequency	$f_V$	-	60	75	Hz		
Hsync Frequency	$f_H$	-	48.36	60.0	kHz		
Main Frequency	$f_{DCLK}$	47	65	80	MHz	(3)	
Rush Current	$I_{rush}$	-	-	1.5	A	(5)	

Note (1) MCLK , Vsync , Hsync , DE , RA0 ~ RA5 , GA0 ~ GA5 , BA0 ~ BA5 , RB0 ~ RB5 , GB0 ~ GB5 , BB0 ~ BB5

(2)  $f_V=60\text{Hz}$ ,  $f_{DCLK}=65\text{MHz}$ ,  $V_{DD} = 3.3\text{V}$ , DC Current.

(3) 1 Pixel/clock

(4) Power dissipation check pattern

\*a) White Pattern

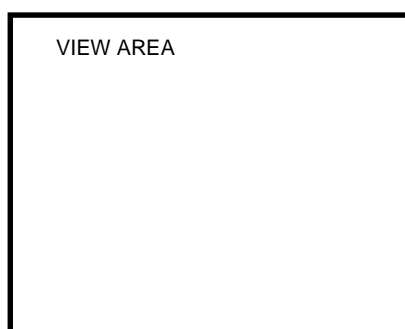

\*b) Mosaic Pattern

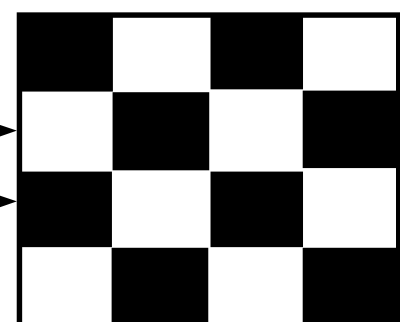

c) Sub-pixel Checker Pattern

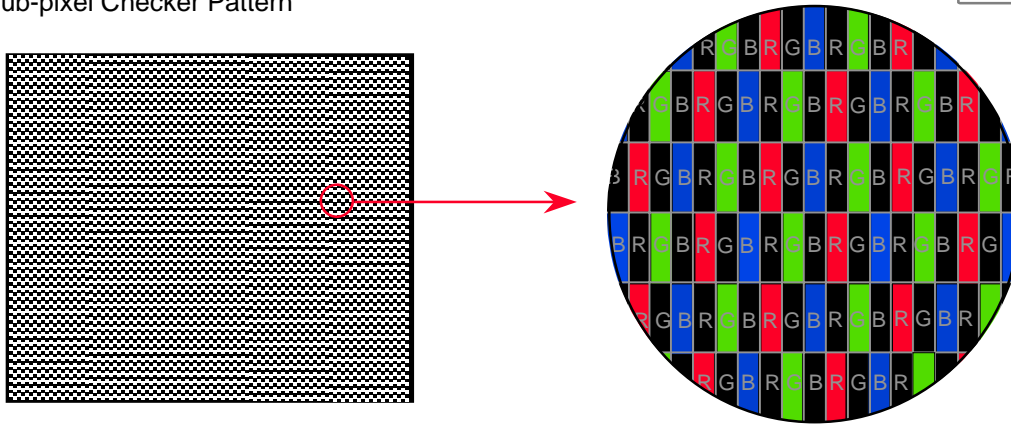

(5) Measurement Conditions

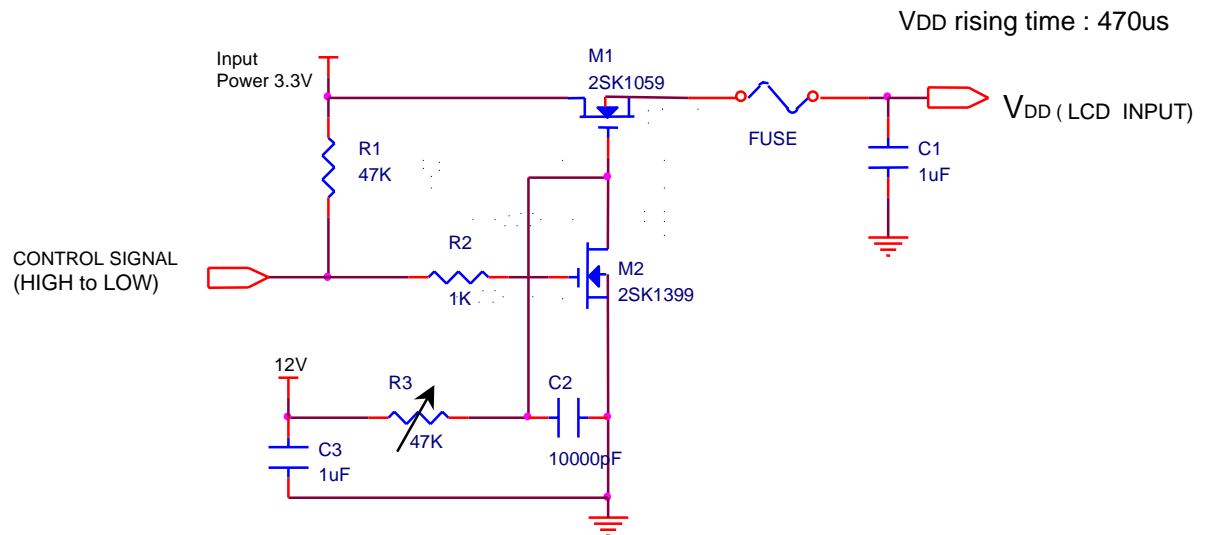

Note : Control Signal : High(+3.3V) -->Low(Ground)

All Signal lines to panel except for power 3.3V : Ground

The rising time of supplied voltage is controlled to 470us by R3 and C2 value.

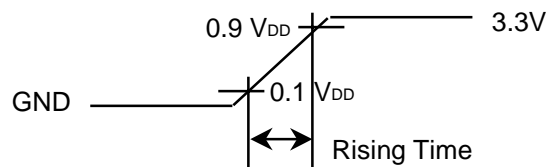

### 3.2 BACK-LIGHT UNIT

The back-light system is an edge-lighting type with 4 CCFTs(Cold Cathode Fluorescent Tube).

The characteristics of four lamps are shown in the following tables.

$T_a = 25 \pm 2 \text{ }^\circ\text{C}$

ITEM	SYMBOL	MIN	TYP	MAX	UNIT	NOTE
Lamp Current	IL	3.0	6.0	6.5	mArms	(1)
Lamp Voltage	VL	-	665	-	Vrms	IL=6.0 mArms
Lamp Frequency	FL	40	-	60	kHz	(2)
Operating Life Time of Lamp	Hr	25,000	35,000	-	Hour	(3)
Startup Voltage	Vs	-	-	1120 (25°C)	Vrms	(4)
				1570 (0°C)		

**Note) The waveform of the inverter output voltage must be area symmetric and the design of the inverter must have specifications for the modularized lamp.**

The performance of the back-light, for example life time or brightness, is much influenced by the characteristics of the DC-AC inverter for the lamp. So all the parameters of an inverter should be carefully designed so as not to produce too much leakage current from high-voltage output of the inverter. When you design or order the inverter, please make sure that a poor lighting caused by the mismatch of the back-light and the inverter(miss lighting, flicker, etc.) never occur. When you confirm it, the module should be operated in the same condition as it is installed in your instrument.

Note (1) Lamp current is measured with current meter for high frequency as shown below.

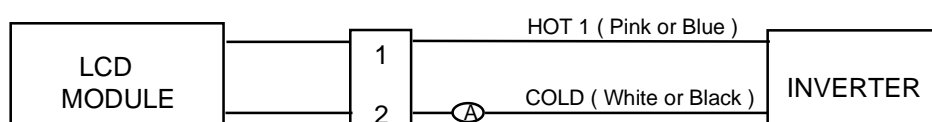

- (2) Lamp frequency may produce interference with horizontal synchronous frequency and this may cause line flow on the display. Therefore lamp frequency shall be detached from the horizontal synchronous frequency and its harmonics as far as possible in order to avoid interference.
- (3) Life time (Hr) of a lamp is defined as the time in which it continues to operate under the condition of  $T_a = 25 \pm 2 \text{ }^\circ\text{C}$  and  $I_L = 6.0 \text{ mArms}$  until the brightness becomes 50% or lower than its original value.
- (4) The voltage above this value should be applied to the lamps for more than 1 second to startup. Otherwise the lamps may not to be turned on.

### 4. BLOCK DIAGRAM

#### 4.1 TFT LCD MODULE

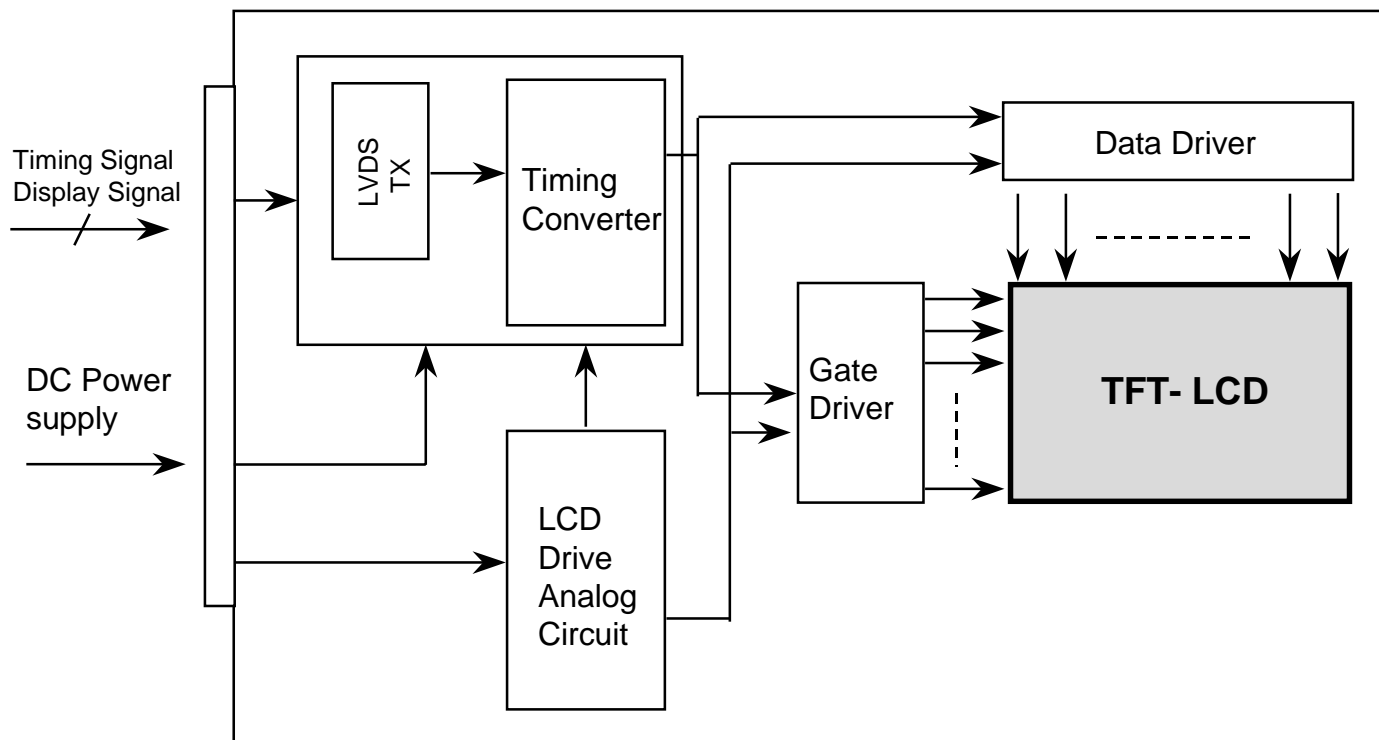

#### 4.2 BACK-LIGHT UNIT

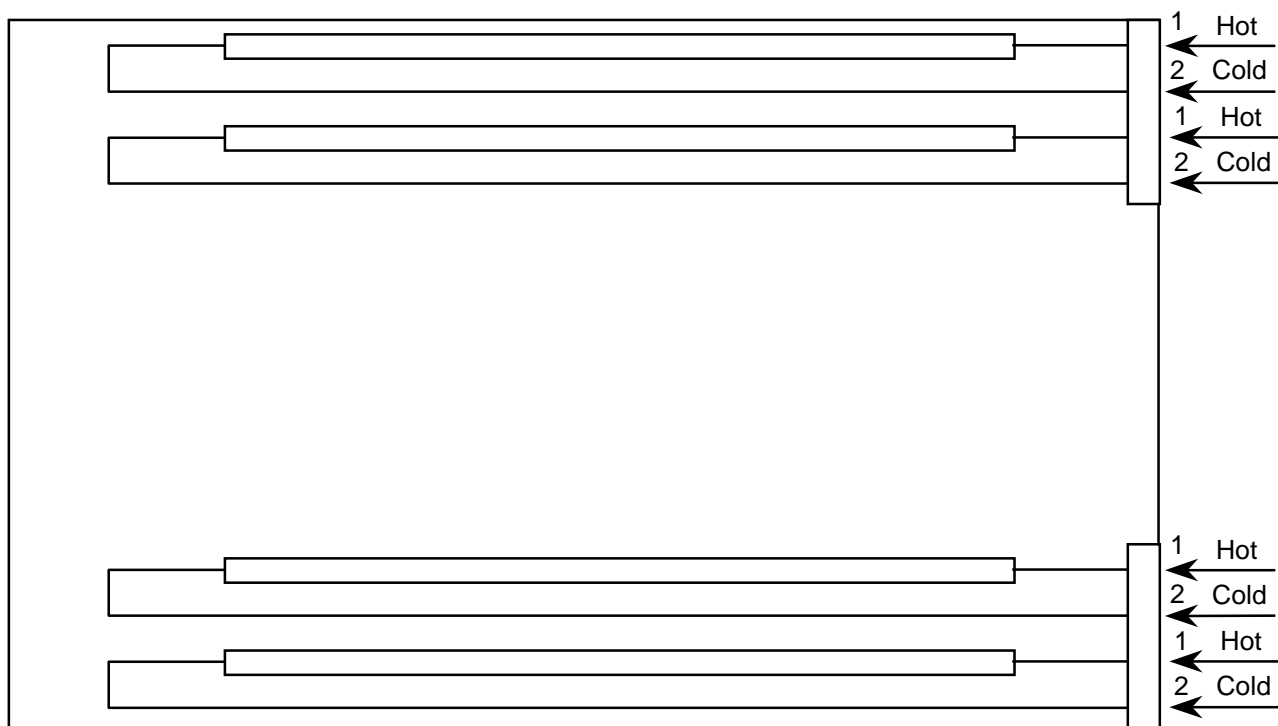

## 5. INPUT TERMINAL PIN ASSIGNMENT

5.1 Input Signal & Power (Interface Connector : Hirose DF14H-30P-1.25H)  
Matching Socket : Hirose DF14-30S-1.25C

Pin NO.	Symbol	Function	Polarity	Remark
1	VDD1	Power Supply [+3.3V]	-	-
2	VDD2	Power Supply [+3.3V]	-	-
3	GND	Ground	-	-
4	MCLK	Clock Signal	-	(1)
5	GND	Ground	-	-
6	VSYNC	Vertical Sync Signal	Negative	-
7	HSYNC	Horizontal Sync Signal	Negative	-
8	DE	Data Enable	Positive	-
9	GND	Ground	-	-
10	RA0	Red Data [LSB]	Positive	-
11	RA1	Red Data	Positive	-
12	RA2	Red Data	Positive	-
13	RA3	Red Data	Positive	-
14	RA4	Red Data	Positive	-
15	RA5	Red Data [MSB]	Positive	-
16	GND	Ground	-	-
17	GA0	Green Data [LSB]	Positive	-
18	GA1	Green Data	Positive	-
19	GA2	Green Data	Positive	-
20	GA3	Green Data	Positive	-
21	GA4	Green Data	Positive	-
22	GA5	Green Data [MSB]	Positive	-
23	GND	Ground	-	-
24	BA0	Blue Data [LSB]	Positive	-
25	BA1	Blue Data	Positive	-
26	BA2	Blue Data	Positive	-
27	BA3	Blue Data	Positive	-
28	BA4	Blue Data	Positive	-
29	BA5	Blue Data [MSB]	Positive	-
30	GND	Ground	-	-

**Note** (1) Display data is sampled at the falling edge of data clock (65MHz Typ).

## 5.2 BACK-LIGHT UNIT

Connector : JST BHSR - 02VS -1  
Mating Connector : SM02B-BHSS-1(JST)

Pin NO.	Symbol	Color	Function
1	HOT	Pink or Blue	High Voltage
2	COLD	White or Black	Ground

## 5.3 Input Signal, Basic Display Colors and Gray Scale of Each Colors

COLOR	DISPLAY	DADA SIGNAL																GRAY SCALE LEVEL		
		RED					GREEN					BLUE								
		R0	R1	R2	R3	R4	R5	G0	G1	G2	G3	G4	G5	B0	B1	B2	B3		B4	B5
BASIC COLOR	Black	0	0	0	0	0	0	0	0	0	0	0	0	0	0	0	0	0	0	-
	Blue	0	0	0	0	0	0	0	0	0	0	0	0	1	1	1	1	1	1	-
	Green	0	0	0	0	0	0	1	1	1	1	1	1	0	0	0	0	0	0	-
	Cyan	0	0	0	0	0	0	1	1	1	1	1	1	1	1	1	1	1	1	-
	Red	1	1	1	1	1	1	0	0	0	0	0	0	0	0	0	0	0	0	-
	Magenta	1	1	1	1	1	1	0	0	0	0	0	0	1	1	1	1	1	1	-
	Yellow	1	1	1	1	1	1	1	1	1	1	1	1	0	0	0	0	0	0	-
	White	1	1	1	1	1	1	1	1	1	1	1	1	1	1	1	1	1	1	-
GRAY SCALE OF RED	Black	0	0	0	0	0	0	0	0	0	0	0	0	0	0	0	0	0	0	R0
	Dark ↑	1	0	0	0	0	0	0	0	0	0	0	0	0	0	0	0	0	0	R1
		0	1	0	0	0	0	0	0	0	0	0	0	0	0	0	0	0	0	R2
		:	:	:	:	:	:	:	:	:	:	:	:	:	:	:	:	:	:	R3 ~ R60
		:	:	:	:	:	:	:	:	:	:	:	:	:	:	:	:	:	:	
	↓ Light	1	0	1	1	1	1	0	0	0	0	0	0	0	0	0	0	0	0	R61
		0	1	1	1	1	1	0	0	0	0	0	0	0	0	0	0	0	0	R62
	Red	1	1	1	1	1	1	0	0	0	0	0	0	0	0	0	0	0	0	R63
GRAY SCALE OF GREEN	Black	0	0	0	0	0	0	0	0	0	0	0	0	0	0	0	0	0	0	G0
	Dark ↑	0	0	0	0	0	0	1	0	0	0	0	0	0	0	0	0	0	0	G1
		0	0	0	0	0	0	0	1	0	0	0	0	0	0	0	0	0	0	G2
		:	:	:	:	:	:	:	:	:	:	:	:	:	:	:	:	:	:	G3 ~ G60
		:	:	:	:	:	:	:	:	:	:	:	:	:	:	:	:	:	:	
	↓ Light	0	0	0	0	0	0	1	0	1	1	1	1	0	0	0	0	0	0	G61
		0	0	0	0	0	0	0	1	1	1	1	1	0	0	0	0	0	0	G62
	Green	0	0	0	0	0	0	1	1	1	1	1	1	0	0	0	0	0	0	G63
GRAY SCALE OF BLUE	Black	0	0	0	0	0	0	0	0	0	0	0	0	0	0	0	0	0	0	B0
	Dark ↑	0	0	0	0	0	0	0	0	0	0	0	0	1	0	0	0	0	0	B1
		0	0	0	0	0	0	0	0	0	0	0	0	0	1	0	0	0	0	B2
		:	:	:	:	:	:	:	:	:	:	:	:	:	:	:	:	:	:	B3 ~ B60
		:	:	:	:	:	:	:	:	:	:	:	:	:	:	:	:	:	:	
	↓ Light	0	0	0	0	0	0	0	0	0	0	0	0	1	0	1	1	1	1	B61
		0	0	0	0	0	0	0	0	0	0	0	0	0	1	1	1	1	1	B62
	Blue	0	0	0	0	0	0	0	0	0	0	0	0	1	1	1	1	1	1	B63

Note) ✓ Definition of Gray :

Rn : Red Gray, Gn : Green Gray, Bn : Blue Gray (n = Gray level)

✓ Input Signal : 0 = Low level voltage, 1 = High level voltage

5.4 PIXEL FORMAT

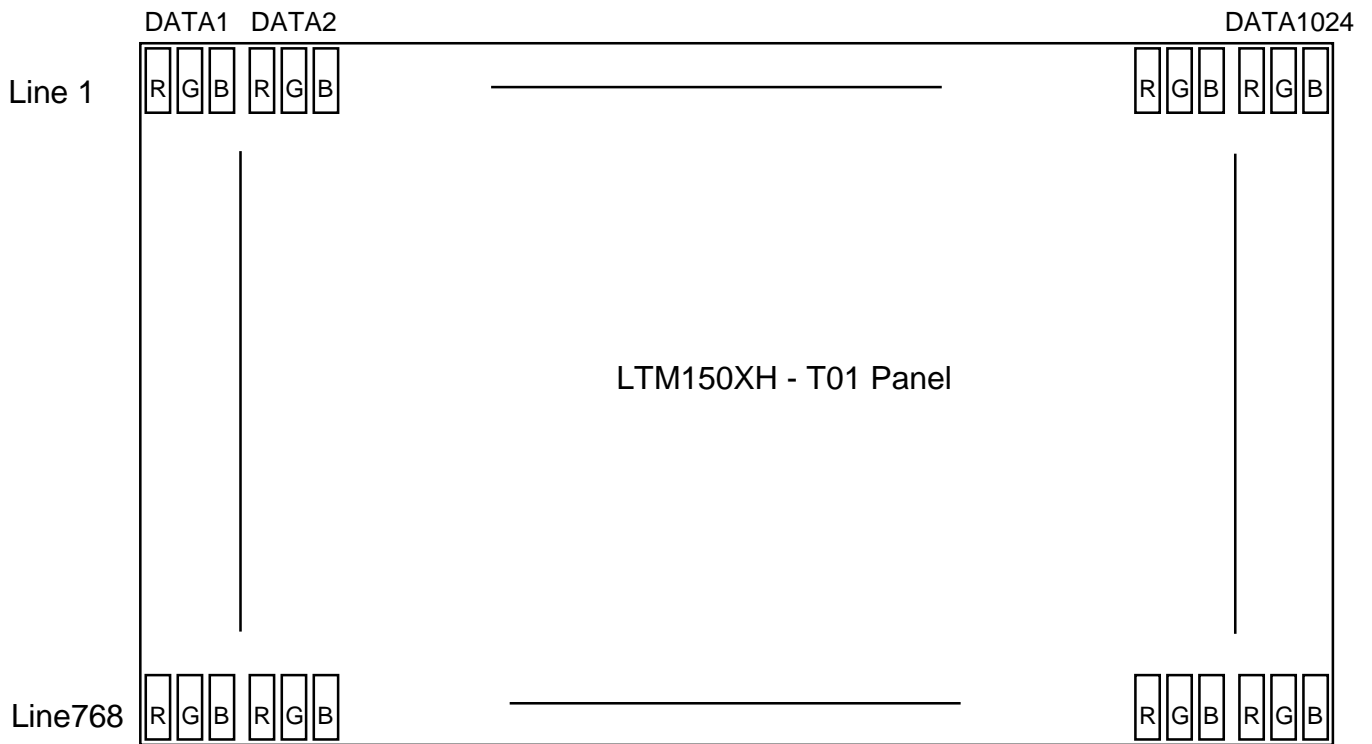

## 6. INTERFACE TIMING

### 6.1 Timing Parameters ( DE only mode )

Signal	Item	Symbol	MIN	TYP	MAX	Unit	Note
Clock	Frequency	1 / Tc	47	65	80	MHz	
	High Time	TCH	4.5	-	-	nsec	
	Low Time	TCL	4.5	-	-	nsec	
Data	Setup Time	TDS	2.7	-	-	nsec	
	Hold Time	TDH	0	-	-	nsec	
Data Enable	Setup Time	TES	2.7	-	-	nsec	(1)
Frame Frequency	Cycle	TV	772	16.7   806	-	msec   lines	
Vertical Active Display Term	Display Period	TVD	768	768	768	lines	
One Line Scanning Time	Cycle	TH	1100	1344	1800	clocks	
Horizontal Active Display Term	Display Period	THD	1024	1024	1024	clocks	

**Note (1) When LTM150XH-T01 model is operated by DE only mode, Hsync and Vsync input signals should be fixed to "Low" for stable operation. Otherwise, the module could operate abnormally.**

6.2 Timing diagrams of interface signal ( DE only mode )

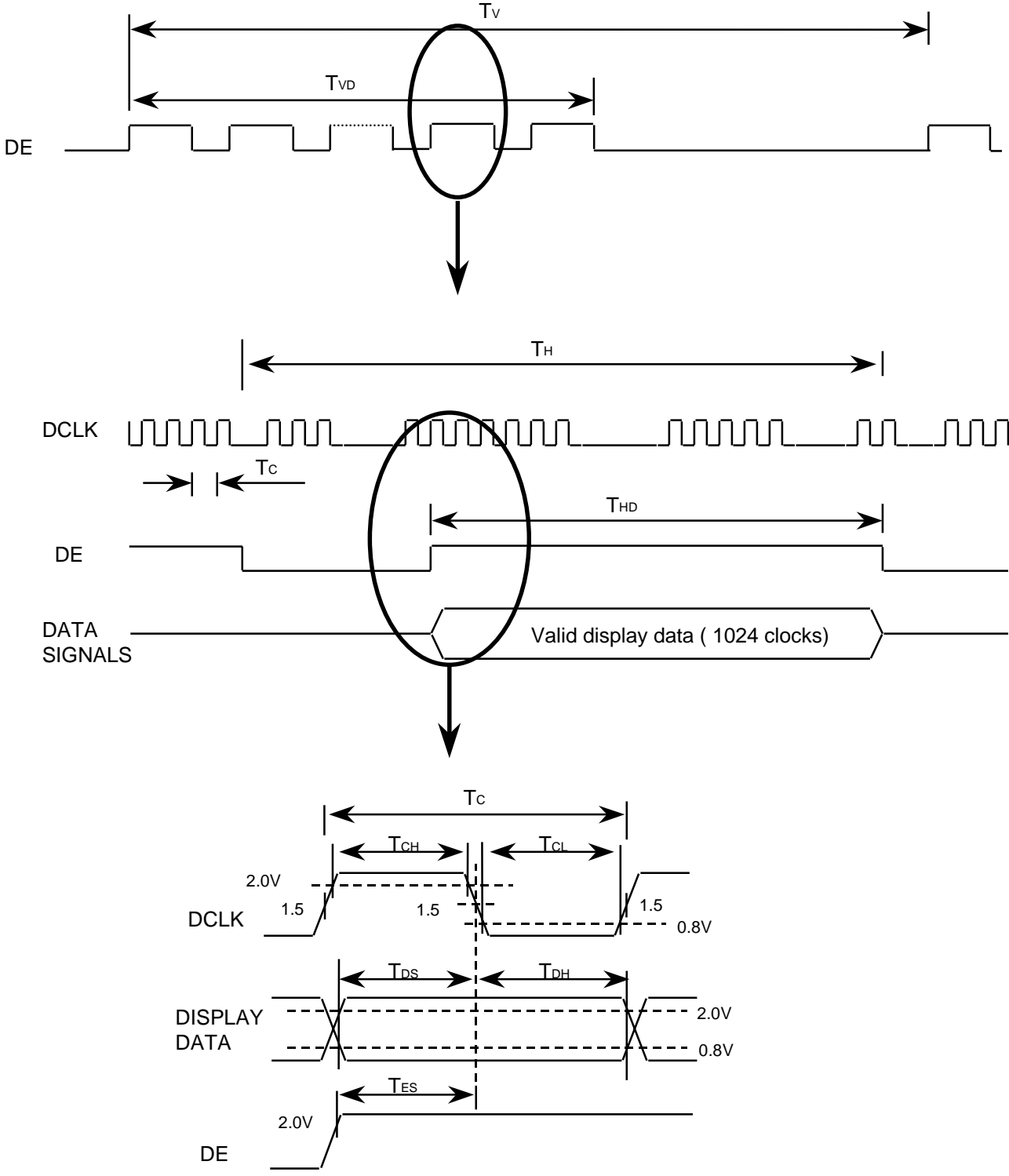

## 6.3 Power ON/OFF Sequence

: To prevent a latch-up or DC operation of the LCD module, the power on/off sequence should be as the diagram below.

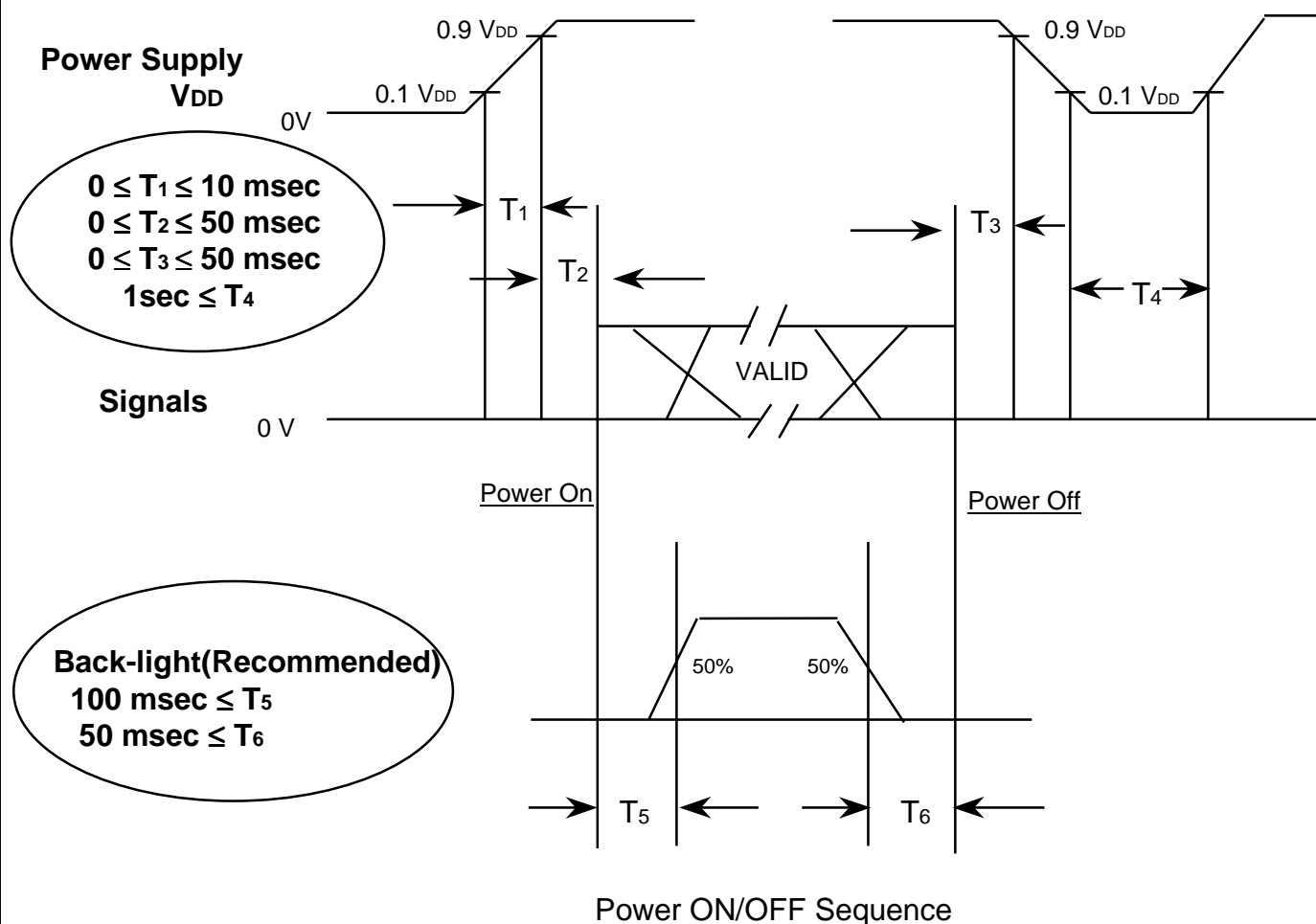

## NOTE.

- (1) The supply voltage of the external system for the module input should be the same as the definition of V<sub>DD</sub>.
- (2) Apply the lamp voltage within the LCD operation range. When the back-light turns on before the LCD operation or the LCD turns off before the back-light turns off, the display may momentarily become white.
- (3) In case of V<sub>DD</sub> = off level, please keep the level of input signals on the low or keep a high impedance.
- (4) T<sub>4</sub> should be measured after the module has been fully discharged between power off and on period.
- (5) Interface signal shall not be kept at high impedance when the power is on.

## 7. OUTLINE DIMENSION

Approval

[ Refer to the next page ]



## 8. RELIABILITY TEST

Test Items	Conditions	Time / Cycle	Sample
HTOL*	50°C, Dynamic	250 hrs	12
LTOL*	0 °C, Dynamic	250 hrs	5
THB*	40°C / 90%, Dynamic	250 hrs	5
HTS****	70°C, No Bias	250 hrs	5
LTS****	-30°C, No Bias	250 hrs	5
Thermal Shock (Non-operating)	-20 ~ 60°C, No bias, Ramp-up & down : 1 min., Soak time : 30min.	100 Cyc.	5
Temperature Characteristics & Power on/off	Storage : 0°C, 30min., 10 times (power on/off) Ramp up : 0~ 25°C, 30 min Storage : 25°C, 30 min., 10 times (power on/off) Ramp up : 20~ 50°C, 30 min. Storage : 50°C, 30 min., 10 times (power on/off) Ramp up : 50~ 0°C, 30 min.	10Cyc.	10
Shock (Non-operating)	50 G, 11 msec, Sine wave, ± x/y/z axis	one time/axis	3
Vibration (Non-operating)	1.5G, 10 ~ 300 ~ 10 Hz, x/y/z axis, sweep rate : 10 min.	30 min/axis	3
ESD (Non-operating)	Contact : 150pF, 330 ohm Air : 150pF, 330 ohm	± 10KV ± 20KV	3 3
Box Vibration	1.1G, 5 ~ 100Hz, 1hour / y axis(up/down), sweep rate : 5min		10
Box Drop	Height : 66cm		10

### [ Result Evaluation Criteria]

Under the display quality test conditions with normal operation state, these shall be no change which may affect practical display function.

\* HTOL/ LTOL : High/Low Temperature Operating Life, \*\* THB : Temperature Humidity Bias

\*\*\*\* HTS/LTS : High/Low Temperature Storage

## 9. PACKING

### 9.1 CARTON(Internal Packing)

(1) Packing Form

Corrugated fiberboard box and corrugated foam as shock absorber

(2) Packing Method

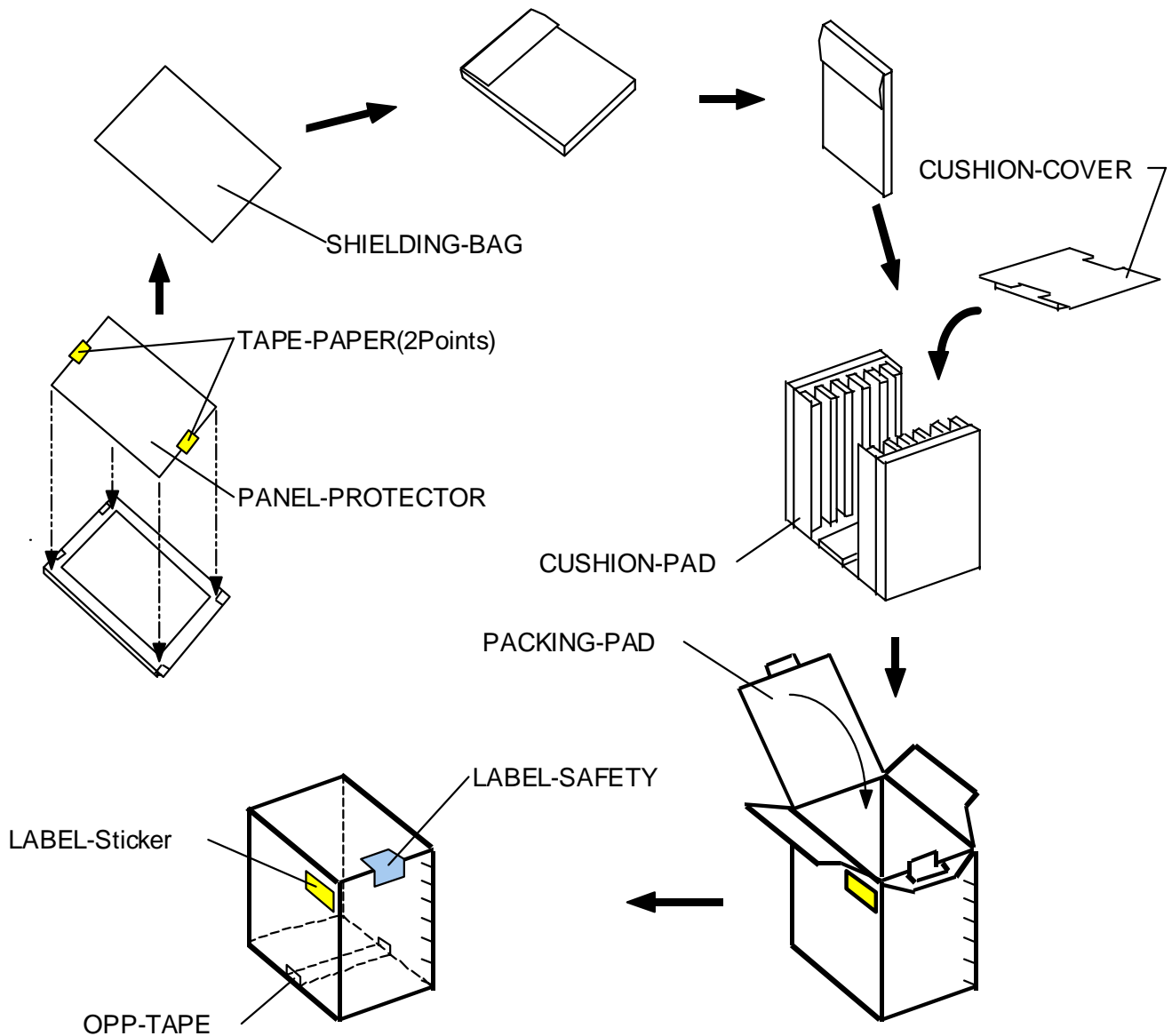

Note (1) Total : Approx. 13.0 Kg

(2) Acceptance number of piling : 10 sets

(3) Carton size : 450 (W) X 348 (D) X 440 (H)

(4) Max accumulation quantity : 7 cartons

(3) Packing Material

No	Part name	Quantity	No	Part name	Quantity
1	PROTECTOR-PANEL	1	6	SHIELDING-BAG	1
2	TAPE-PAPER	0.06MT	7	OPP-TAPE	0.2MT
3	PACKING-CASE	0.1	8	LABEL-STICKER	1
4	CUSHION-PAD	0.1	9	LABEL-SAFETY	1
5	CUSHION-COVER	0.1			

**10. MARKING & OTHERS**

A nameplate bearing followed by is affixed to a shipped product at the specified location on each product.

(1)Parts number : LTM150XH-T01

(2)Revision : One letter

(3)Control Code : One letter

(4)Lot number : 4 K 0 H 123 01 01

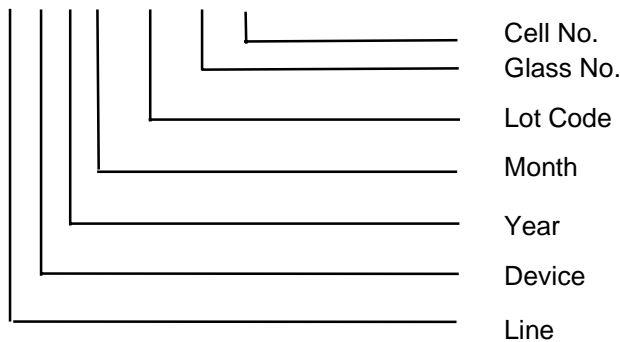

(5) Nameplate Indication

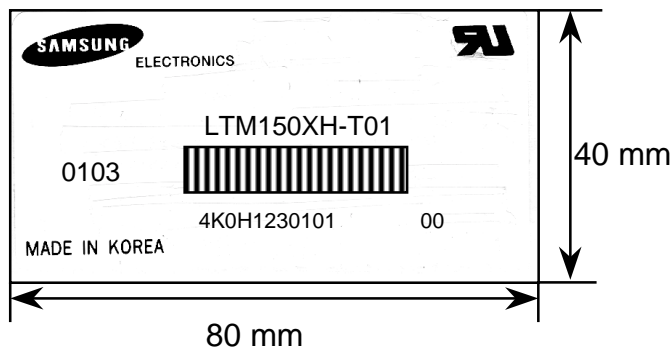

Parts name : LTM150XH-T01  
 Lot number : 4K0H1230101  
 Inspected work week : 0103

■ High voltage caution

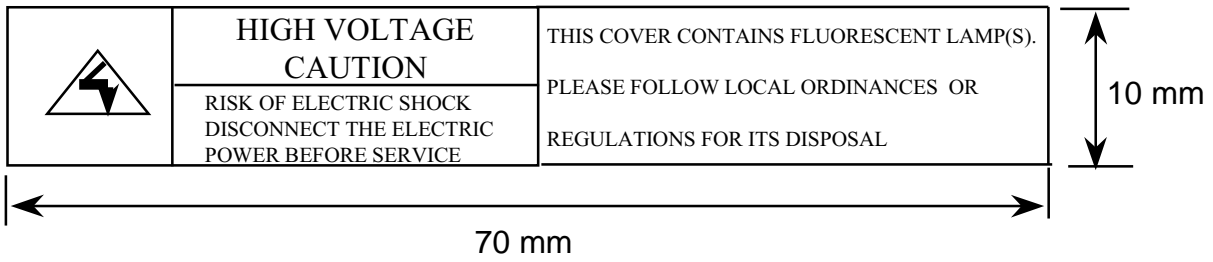

(6) Packing box attach

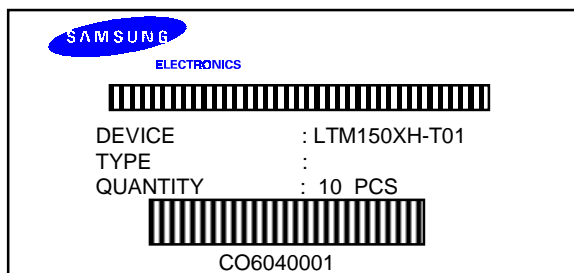

## 11. General Precautions

### 11.1 Handling

- (a) When the module is assembled, It should be attached to the system firmly using every mounting holes. Be careful not to twist and bend the modules.
- (b) Refrain from strong mechanical shock and / or any force to the module. In addition to damage, this may cause improper operation or damage to the module and CCFT back-light.
- (c) Note that polarizers are very fragile and could be easily damaged. Do not press or scratch the surface harder than a HB pencil lead.
- (d) Wipe off water droplets or oil immediately. If you leave the droplets for a long time, Staining and discoloration may occur.
- (e) If the surface of the polarizer is dirty, clean it using some absorbent cotton or soft cloth.
- (f) The desirable cleaners are water, IPA(Isopropyl Alcohol) or Hexane. Do not use Ketone type materials(ex. Acetone), Ethyl alcohol, Toluene, Ethyl acid or Methyl chloride. It might permanent damage to the polarizer due to chemical reaction.
- (g) If the liquid crystal material leaks from the panel, it should be kept away from the eyes or mouth. In case of contact with hands, legs or clothes, it must be washed away thoroughly with soap.
- (h) Protect the module from static, it may cause damage to the C-MOS Gate Array IC.
- (i) Use finger-stalls with soft gloves in order to keep display clean during the incoming inspection and assembly process.
- (j) Do not disassemble the module.
- (k) Do not pull or fold the lamp wire.
- (l) Do not adjust the variable resistor which is located on the back side.
- (m) Pins of I/F connector shall not be touched directly with bare hands.

## 11.2 Storage

- (a) Do not leave the module in high temperature, and high humidity for a long time.  
It is highly recommended to store the module with temperature from 0 to 35 °C and relative humidity of less than 70%.
- (b) Do not store the TFT-LCD module in direct sunlight.
- (c) The module shall be stored in a dark place. It is prohibited to apply sunlight or fluorescent light during the store.

## 11.3. Operation

- (a) Do not connect, disconnect the module in the “ Power On” condition.
- (b) Power supply should always be turned on/off by following item 6.6 “ Power on/off sequence “.
- (c) Module has high frequency circuits. Sufficient suppression to the electromagnetic interference shall be done by system manufacturers. Grounding and shielding methods may be important to minimize the interference.
- (d) The cable between the back-light connector and its inverter power supply shall be a minimized length and be connected directly . The longer cable between the back-light and the inverter may cause lower luminance of lamp(CCFT) and may require higher startup voltage(Vs).

## 11.4 Others

- (a) Ultra-violet ray filter is necessary for outdoor operation.
- (b) Avoid condensation of water. It may result in improper operation or disconnection of electrode.
- (c) Do not exceed the absolute maximum rating value. ( the supply voltage variation, input voltage variation, variation in part contents and environmental temperature, so on)  
Otherwise the module may be damaged.
- (d) If the module displays the same pattern continuously for a long period of time, it can be the situation when the image “sticks” to the screen.
- (e) This module has its circuitry PCB's on the rear side and should be handled carefully in order not to be stressed.

## # Appendix

# Cosmetic Outgoing Inspection Specification ( LTM150XH XGA TFT LCD)

**Customer** \_\_\_\_\_

**Samsung**  \_\_\_\_\_

J. S. Shim  
Sr. Manager. AM LCD CS Group

**TCS Team**  
**AM LCD DIVISION**  
**SAMSUNG ELECTRONICS.CO**

# 1. Outgoing Inspection

## 1.1 Outgoing Inspection Plan

### 1.1.1 Sampling Plan

- + Reference : MIL-STD-1234A.
  - + Assured quality level : \*AOQL 3,754 DPPM
  - + Sample size : 40 %
- (\*AOQL : Average Outgoing Quality Limit)

### 1.1.2 Flow Chart

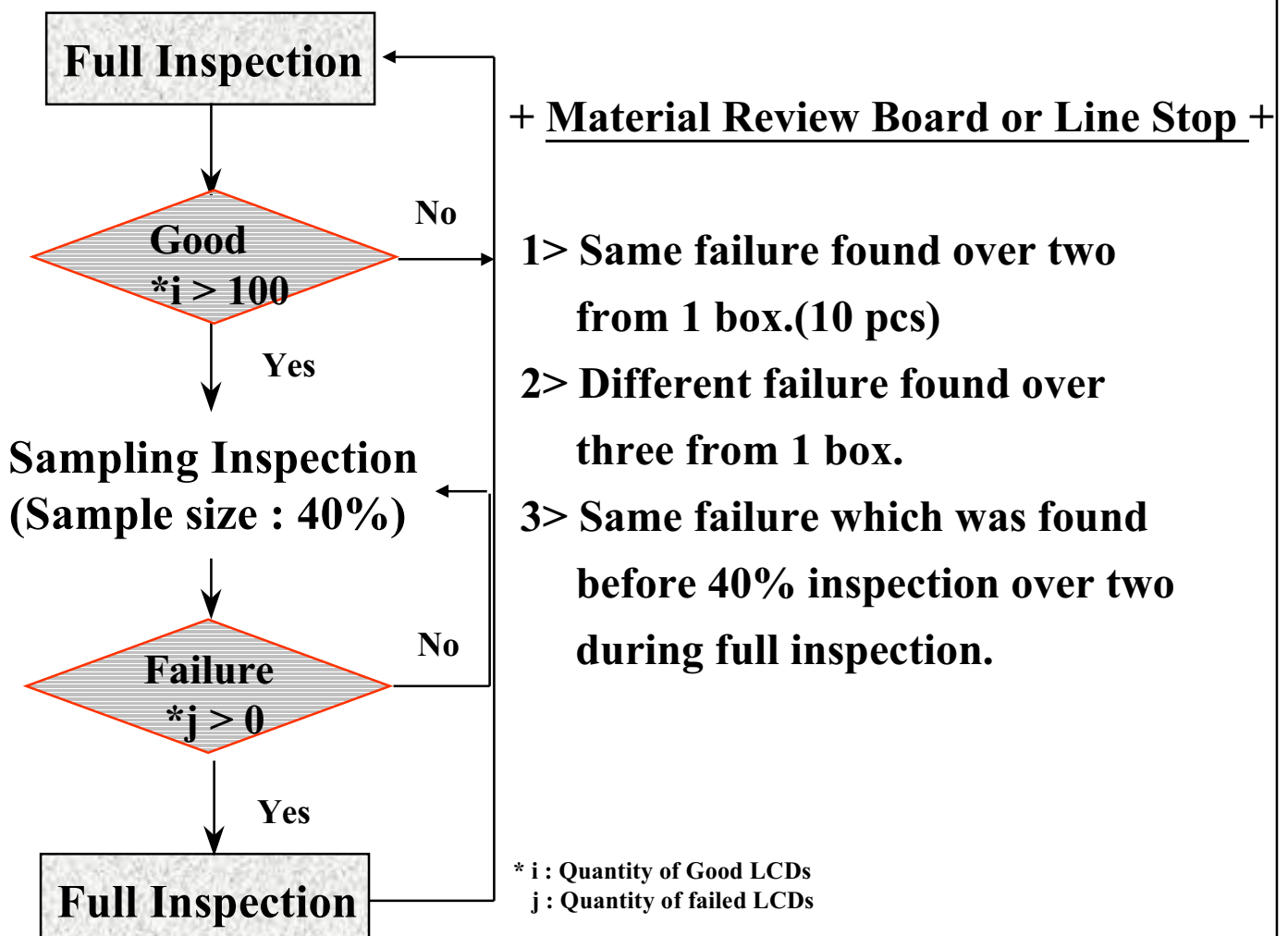

## 1.2 Outgoing Inspection Criteria

### 1.2.1 Inspection Introduction

#### 1.2.1.1 Conditions

<i>viewing distance</i>	30 ~ 50 cm
<i>ambient illumination</i>	300 ~ 700 Lux (nominal 500 Lux)
<i>ambient temperature</i>	25 + - 3 'C
<i>viewing angle</i>	The surface of the module and the inspector's line of view shall be at 90 degrees.
<i>display pattern</i>	XGA - R, G, B, Black, White
<i>inspection area</i>	active area

#### 1.2.1.2 Defect Modes

##### *dark / bright spots*

points on the display which appear dark / bright and remain unchanged in size

##### *dark / bright lines*

lines on the display which appear dark / bright and remain unchanged in size

##### *polarizer scratch*

when the unit is lit a light, line is seen across a darker background; line does not vary in size

##### *polarizer dent*

when the unit is lit a light, light(white) spots appear against a darker background, and do not vary in size

##### *bright/dark dot*

a sub-pixel (R, G, B dot) stuck off / on

## 1.2.2 Mechanical Inspection

<i>Chassis Gap</i>	max. 0.7mm
<i>Silicone Gasket (Glue)</i>	silicone material shall not be exposed beyond the metal frame edge into the view area
<i>Light Leakage</i>	there shall be no visible light around the edges of the screen.

\* *If there is none identified criteria in this specification, Samsung will refer production specification that Customer and Samsung agreed.*

\* *If there is mechanical dimension issue which has no designated tolerance, Samsung will apply natural tolerance.*

## 1.2.3. Visual Inspection

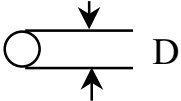
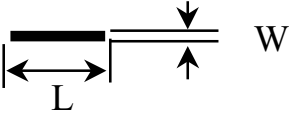
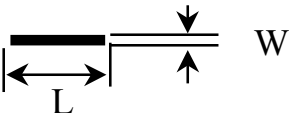
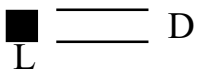
Defect Type	Count (mm)	Reject (mm)
<i>Dark / bright spot <sup>*1</sup></i> <i>(foreign circular matter)</i> 	$0.1 < D \leq 0.8$ $N \leq 4$	$D > 0.8$
<i>Bright line (light lint), or</i> <i>dark line (dark lint / hair)</i> 	$0.01 < W \leq 0.1$ $0.3 < L \leq 3.0$ $N \leq 4$	$W > 0.1$ $L > 3.0$
<i>Polarizer scratch</i> 	$0.01 < W \leq 0.1$ $0.3 < L \leq 10.0$ $N \leq 3$	$W > 0.1$ $L > 10.0$
<i>Polarizer dent/bubble</i> 	$D \leq 0.5$ $N \leq 3$	$D > 0.5$
<i>Maximum allowable number of defects</i>	$N \leq 7$	$N > 7$

[ D : diameter, W : width, L : length, N : count ]

*\*1 : Translucent edge is ignored in measuring the diameter of spot.*

## 1.2.4 Electrical Inspection

Defect Type	Accept	Reject
<i>Bright dot</i>		
<i>random</i>	$N \leq 6$ (green $\leq 3$ )	$N > 6$ (green $> 3$ )
<i>two adjacent</i>	$N \leq 1$	$N > 1$
<i>Dark dot, (Fig. 1)</i>		
<i>random</i>	$N \leq 7$	$N > 7$
<i>two adjacent</i>	$N \leq 3$	$N > 3$
<i>three adjacent</i>	$N \leq 2$	$N > 2$
<i>four or more adjacent</i>	Not allowed	
<i>Maximum allowable number of dot defect</i>	$N \leq 10$	$N > 10$
<i>Minimum distance between defects, (Fig. 2)</i>		
<i>bright dot - to - bright dot</i>	$L \Rightarrow 15\text{mm}$	$L < 15\text{mm}$
<i>dark dot - to - dark dot</i>	$L \Rightarrow 5\text{mm}$	$L < 5\text{mm}$

[ L : length, N : count ]

*Inspection pattern for electrical defect should be pure R, G, B, Black and White.*

*Image sticking*

When changing pattern after 30 minutes display with same pattern, the previous image shall not be to persist longer than 10 seconds.

Fig. 1. Bright dot defect description

[two adjacent]

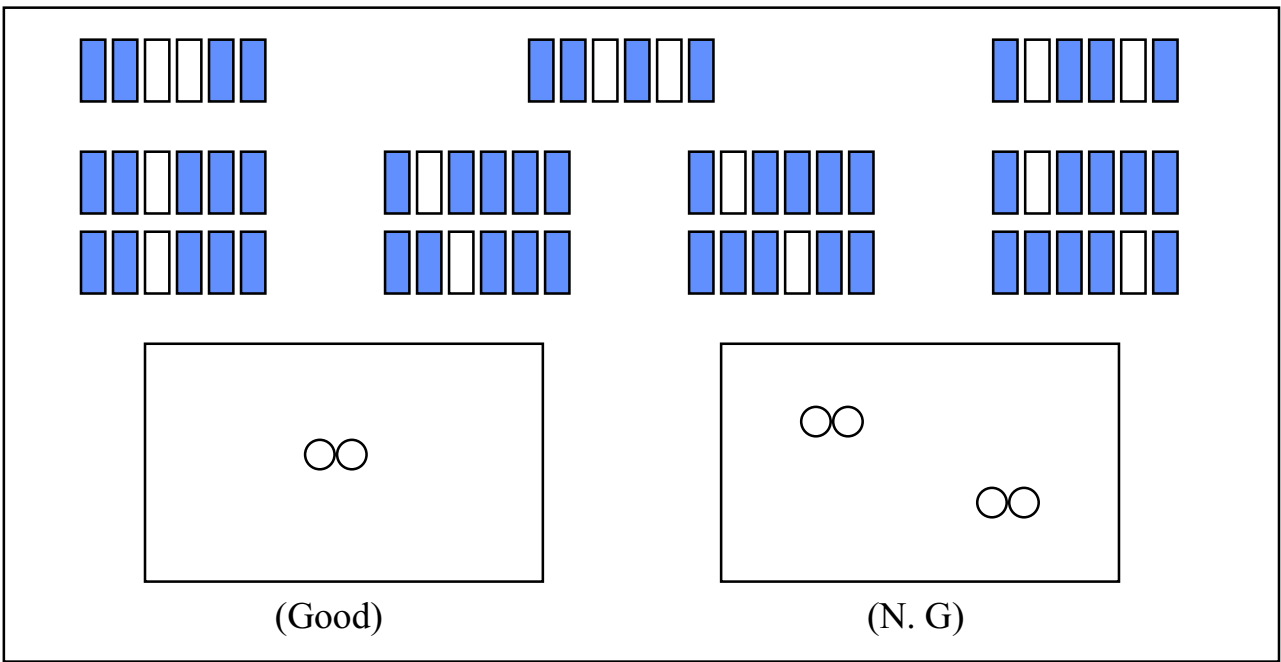

Fig. 2. Dark dot defect description

[two adjacent]

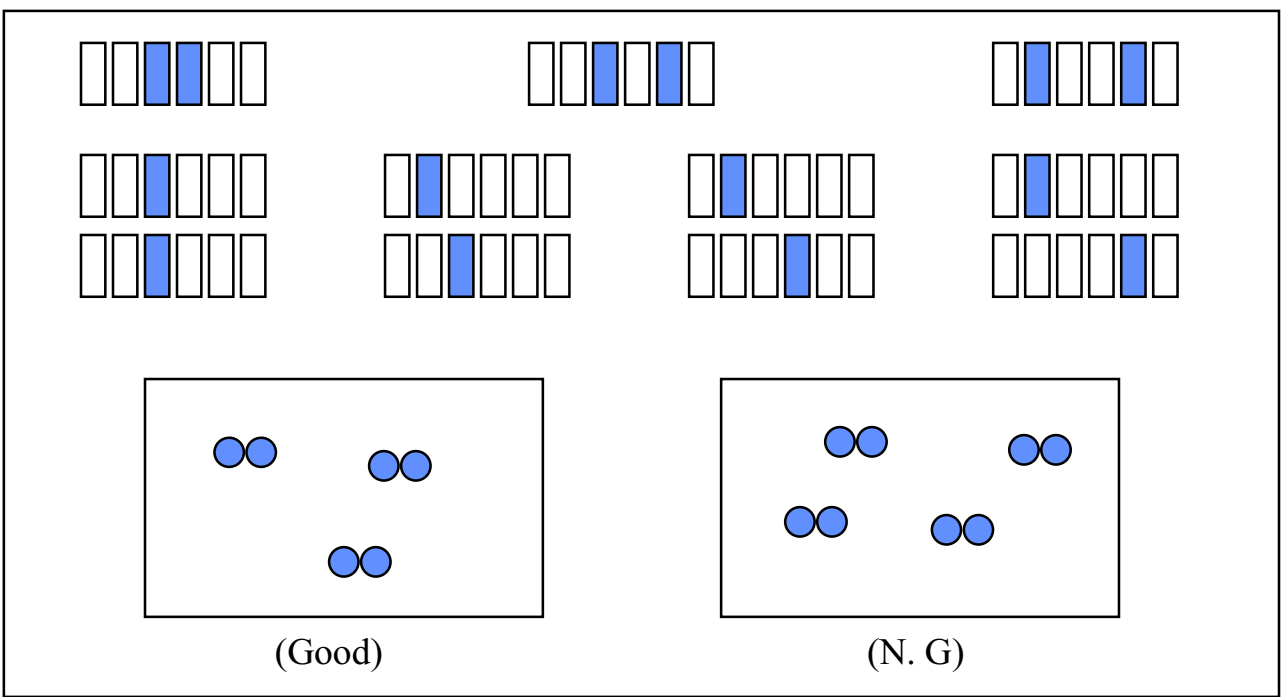

Fig. 2. Dark dot defect description - continued

[three adjacent]

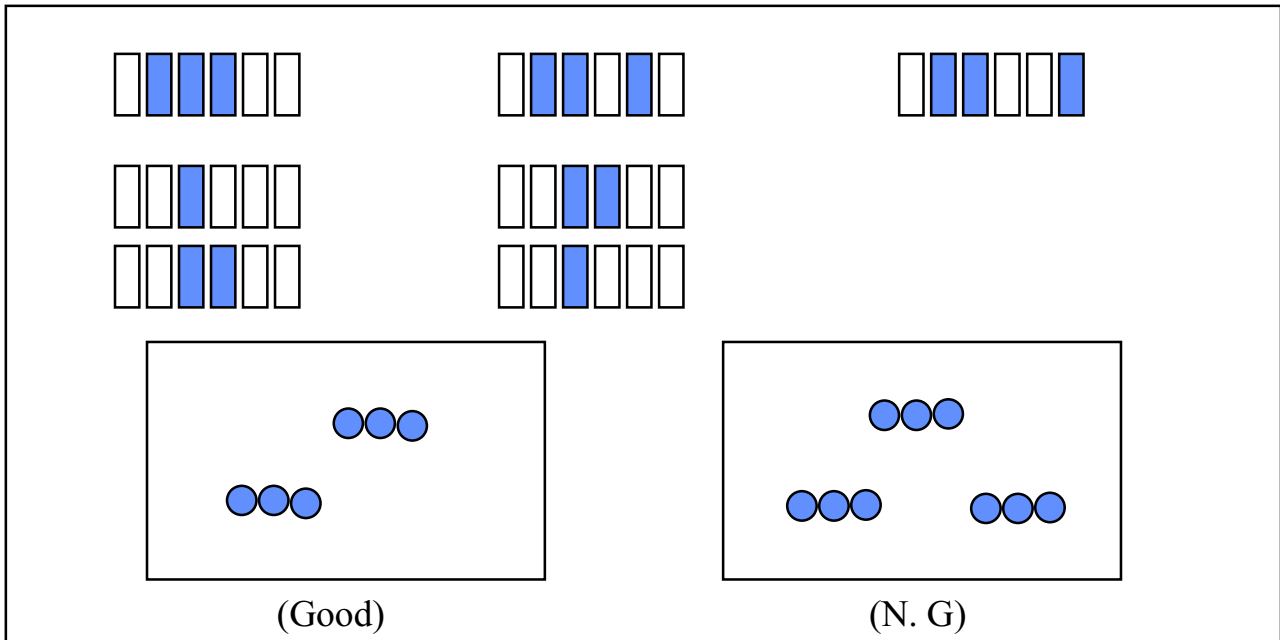
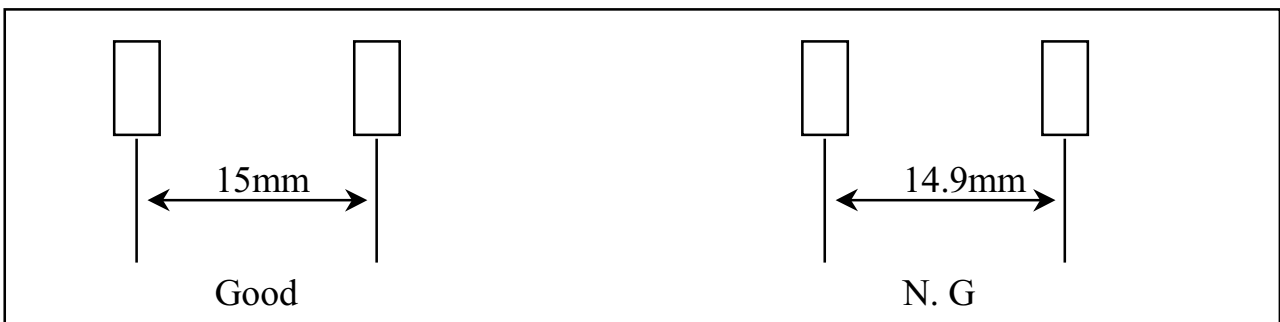

Fig. 3. Minimum distance between dot defects

[bright dot - to - bright dot]



[dark dot - to - dark dot]

