



ELECTRONICS

Product Information

ISSUE DATE : 2001-06-05

MODEL : LTM150Xi-A01

Note : This Product information is subject to change after 3 months of issuing date

Prepared by AMLCD Application Engineering Group

Samsung Electronics Co . , LTD.

Contents

1. General Description ----- 3

2. Electrical Absolute Ratings ----- 5

3. Environmental Specification ----- 5

4. Optical Characteristics ----- 6

5. Electrical Specification

 5.1 Input video and sync signal ----- 11

 5.2 Input Signal Pin Assignment ----- 12

 5.3 Function Key Pin Assignment and Description ----- 13

 5.4 Power Supply ----- 13

 5.4.1 Pin Assignment and description -

 5.4.2 Input voltage & Rush current

 5.4.3 DPMS: VESA DPMS compliance

 5.5 Power Consumption ----- 13

 5.5.1 Measurement of power consumption

 5.5.2 Power management mode: VESA DPMS protocol applied

 5.6 Display Modes ----- 15

6. User Interface ----- 16

 6.1 OSD Key Matrix

 6.2 User Controls

7. Microprocessor ----- 17

8. Mechanical Specification

 8.1 Outline dimension ----- 19

 8.2 Packing Information ----- 21

9. GENERAL PRECAUTION ----- 23

 9.1 Handling

 9.2 Storage

 9.3 Operation

 9.4 Others

※ Appendix 1: Timing Table of Display modes ----- 25

※ Appendix 2: EDID Specification (DDC Data Structure ----- 26

1. General Description

LTM150XI-A01 is a new concept of System-On-Panel (SOP) display device. It provides total and high quality TFT-LCD display solutions for customer system design. Customer can use the high quality display unit just like an integrated circuit (IC).

As ICs are used as building blocks of many complicated electronic systems, this new display solution can be used just same.

This device includes the high quality TFT-LCD panel and the high brightness 4-lamp backlight unit with the optimized inverter. Integrated signal processing unit, named LSP (LCD Signal Processor™), includes all electronic function for user application. It includes analog-to-digital conversion, Scaling, OSD, EDID (DDC 2 compliance) and LCD Timing controller. More functions are available, also.

World-top notebook LCD design technology of Samsung realize the most compact solution. Customer can enjoy wide system design flexibility.

EMI is the additional point of this device. All of the units are shielded by metal case finally.

* Features

- High display quality : High contrast ratio, Wide-viewing angle and High-speed response time.
- High brightness with the 4-CCFL backlight lamps using optimized inverter.
- Samsung's own *Smart Inverter Control(SIC)* technology will be supported. (TBD)
- Standard interface: Analog RGB and Composite video input (YUV and S-VIDEO).
 - ※ Interface solution is shown in next page.
- On Screen Display(OSD): Samsung generic bitmap OSD is supported, but the customized OSD is also available using system development tool.
- Digital Image Processor is embedded with intelligent microprocessor.
- Wide Input Voltage Range : +9VDC ~ +20VDC
- DDC Ver. 2 Compliance by system integrator
- VESA DPMS compliance
- Low Power Consumption
- Easier EMI troubleshooting and solution supported.
- Easy Lamp replacement

* Information

Items	Specification	Unit	Note
Display area	304.1(H) x 228.1(V)	mm	15.0 inch diagonal
Driver element	a-Si TFT active matrix		
Display colors	16.7M (true)	colors	
Number of pixels	1024 x 768	pixel	
Pixel arrangement	RGB vertical stripe		
Pixel pitch	0.297(H) x 0.297(W)	mm	
Display mode	Normally White		
Surface treatment	Haze 25% , Hard-coating (3H)		
Lamp	4-Lamp		

*** Mechanical information**

Item		Min.	Typ.	Max.	Note
Module size	Horizontal(H)	331.1	331.6	332.1	mm
	Vertical(V)	254.8	255.3	255.8	mm
	Depth(D)	-	-	18.0	mm
Weight		-	-	(1800)	g

2. Electrical Absolute Ratings

(1) TFT LCD Module

(V_{ss} = GND = 0 V)

Item	Symbol	Min.	Max.	Unit	Note
Power Supply Voltage	VDD	-0.3	+21	V	(1)

NOTE (1) Within Ta (25 ± 2 °C)

3. Environmental Specification

Items	Min.	Max.	Units	Note
Storage Temperature	-25	+60	°C	
Operating Temperature	0	+50	°C	
Shock (Non-operating)	-	50	G	11ms, 1 time for ±X, ±Y, ±Z
Vibration (Non-operating)	-	1.5	G	10-300Hz, Sweep rate:10min, 30min for X, Y, Z axis

■ Note: If this product is used for extended time excessively or exposed to high temperatures for extended time, there is a possibility of wide viewing angle film damage which could affect visual characteristics.

4. Optical Characteristics

The following items are measured under stable conditions. The optical characteristics should be measured

in a dark room or equivalent state with the methods shown in Note (1).

※Measuring equipment : TOPCON BM-5A: Contrast Ratio, Luminance of White, Viewing Angle

TOPCON BM-7: Response time, Flicker

Photo Research PR650: Color Chromaticity

※Ta = 25± 2℃ , VIN = +12V, fv= 60Hz, IL = 6.0mA

Item		Symbol	Condition	Min	Typ	Max	Unit	Note
Contrast Ratio		CR		(200)	300	-		(1),(2),(4)
Response Time at Ta	Rising	T _R	Φ=0, Θ=0	-	5	-	msec	(1), (3)
	Falling	T _F		-	20	-		
Luminance of White (Center of Screen)		Y _L	Normal Viewing Angle	(200)	250	-	cd/m ²	(1),(4)
Color Chromaticity (CIE 1931)	Red	R _X		(0.603)	(0.628)	(0.653)		(1), (4)
		R _Y		(0.328)	(0.353)	(0.378)		
	Green	G _X		(0.265)	(0.290)	(0.315)		
		G _Y		(0.570)	(0.595)	(0.620)		
	Blue	B _X		(0.119)	(0.144)	(0.169)		
		B _Y		(0.063)	(0.088)	(0.113)		
White	W _X	0.279		0.304	0.329			
	W _Y	0.300	0.325	0.350				
Viewing Angle	Hor.	Θ _L	CR≥10	(65)	-	-	Degrees	
		Θ _R		(65)	-	-		
	Ver.	Φ _H		(50)	-	-		
		Φ _L		(60)	-	-		
Color Gamut				-	(65)	-	%	
Brightness Uniformity (9 points)		B _{UNI}		-	-	(20)	%	(5)

■ Measuring Condition: Maximum value of Brightness and Contrast in OSD menu.

■ Flicker must be controlled internally. Customer specification need to exclude this item.

Note 1) Definition of Viewing Angle : Viewing angle range ($10 \leq CR$)

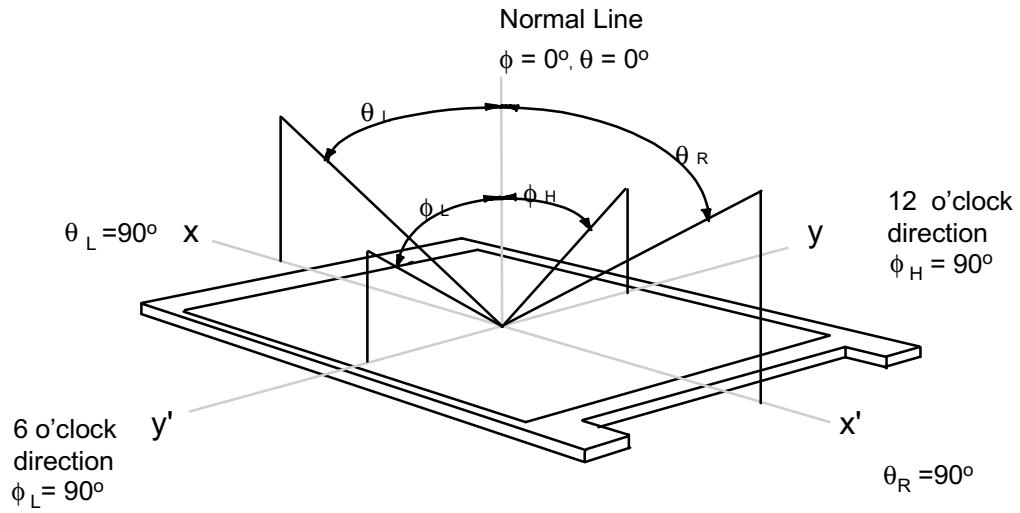

Note 2) Definition of Contrast Ratio (CR) : Ratio of gray max (Gmax) ,gray min (Gmin) at the center point of panel.

$$CR = \frac{\text{Luminance with all pixels white (Gmax)}}{\text{Luminance with all pixels black (Gmin)}}$$

Note 3) Definition of Response time : Sum of T_R, T_F

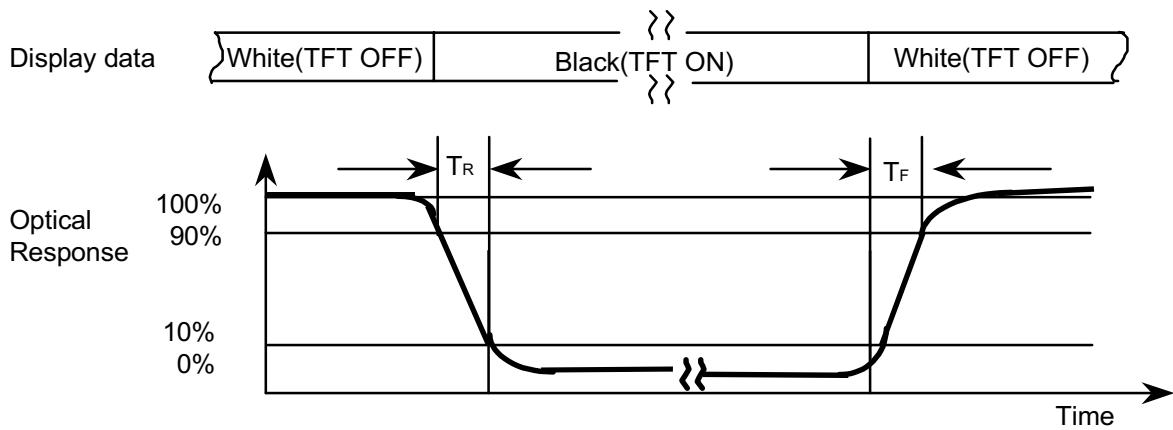

Note 4) After stabilizing and leaving the panel alone at a given temperature for 30 min , the measurement should be executed. Measurement should be executed in a stable, windless, and dark room. 30 min after lighting the back-light. This should be measured in the center of screen.
Lamp current : 6.0mA
Environment condition : $T_a = 25 \pm 2 \text{ }^\circ\text{C}$

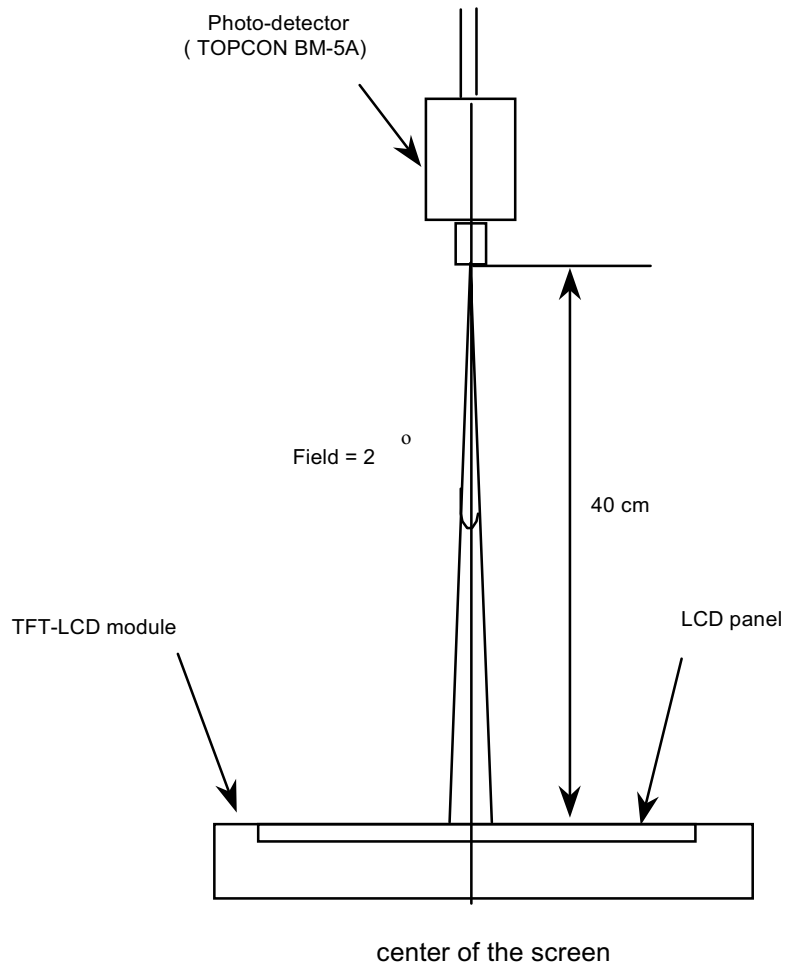

Optical characteristics measurement setup

Note 5) Definition of 9 points brightness uniformity

$$B_{UNI} = \frac{|B_{max \text{ or } B_{min}} - B_{ave}|}{B_{ave}} \times 100$$

B_{max} : Maximum Brightness

B_{min} : Minimum Brightness

$$B_{ave} : \text{Average Brightness} = \frac{\sum_{k=1}^9 (B(k))}{9}$$

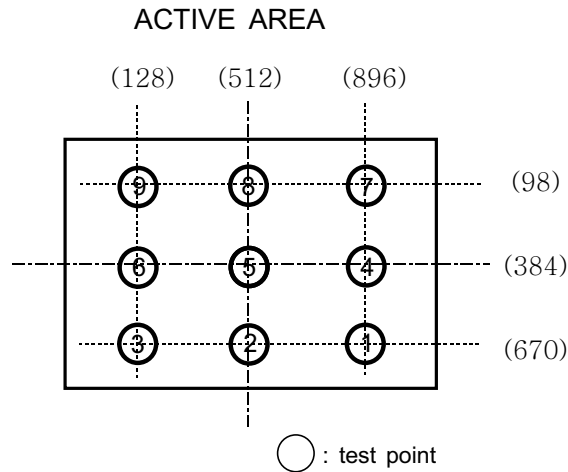

Note 6) Measuring Equipment: BM-7, Distance: 50cm

① Calculation Spec.: SG029300

② Measuring point

③ Pattern: 1dot pattern (Gray #21, #31, #44)

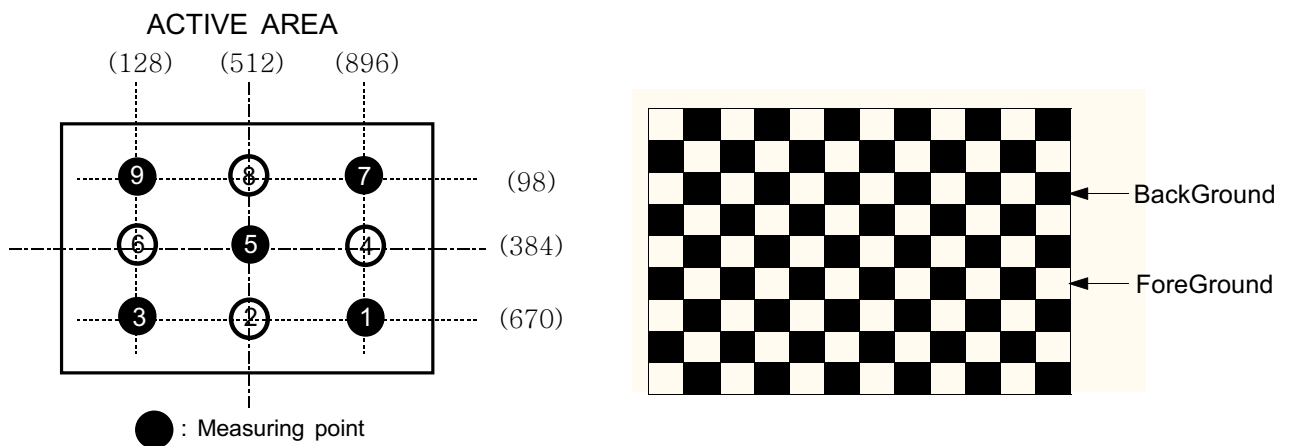

Note 7) Definition of Crosstalk (C_T)

$$\text{Crosstalk Modulation Ratio}(D_{SHA}) = \frac{|Y_A - Y_B|}{Y_A} \times 100 (\%)$$

※ $Y_A, Y_B = 2^\circ$ Viewing Angle (Measurement Area on Panel : $\phi 12\text{mm}$)

※ Background expect Black bar = Gray 1 ~ 63

① Horizontal Crosstalk

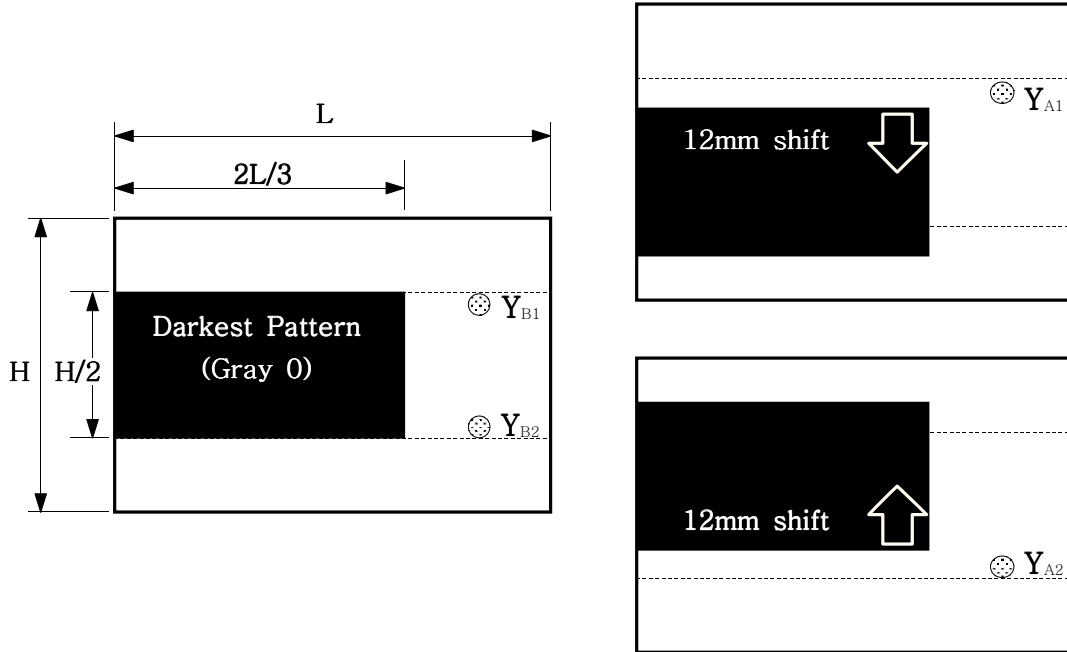

② Vertical Crosstalk

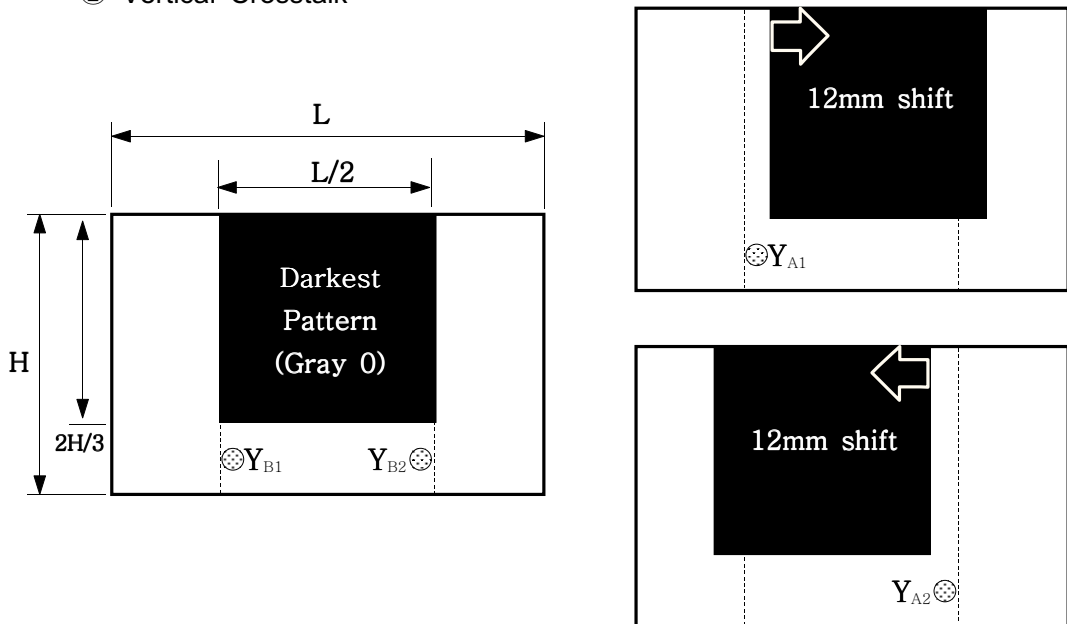

5. Electrical Specification

5.1 Input video and sync signal

* Signal Connector : S13B-PH-SM3-TB (JST)

☞ Mating Connector : PHR-13

Item		Description	Notes
Video	Input	<ul style="list-style-type: none"> · Type: Analog RGB · level : 0.7Vp-p ±5% · Polarity: Positive Bright · Impedance: 75Ω±5% (Terminated) 	VESA Compliance
	Resolution	<ul style="list-style-type: none"> · Optimum: 1024×768@60Hz · Maximum: 1280×1024@60Hz 	Down Scaling mode
	Horizontal Frequency	<ul style="list-style-type: none"> · 30-61KHz (normal mode) · 30-69KHz (Failure Safe mode) 	
	Vertical Frequency	<ul style="list-style-type: none"> · 55-75Hz (normal mode) · 55-75Hz (Failure Safe mode) 	
	Applicable Bandwidth	<ul style="list-style-type: none"> · Typical: 95MHz (1024x768@85Hz) · Max: 108MHz (1280x1024@60Hz) 	Depends on ADC specification
	Sync Signal	<ul style="list-style-type: none"> · Type: Separate H/V sync, Composite H/V sync, Sync-on-green (SOG) · Level: TTL level (V high≥2.0V, V low≤0.8V) · Polarity: Positive or negative · Termination resistance: more than 2KΩ 	
Sync	Input	<ul style="list-style-type: none"> · Type : separate H/V sync, Composite, SOG(Sync-On-Green) · Level : TTL level (V high ≥ 2.0V, V low ≤ 0.8V) · Polarity : Positive or negative. 	
	Horizontal Frequency	<ul style="list-style-type: none"> · 30-61KHz (normal mode) · 30-69KHz (Failure Safe mode) 	
	Vertical Frequency	<ul style="list-style-type: none"> · 55-75Hz (normal mode) · 55-75Hz (Failure Safe mode) 	

5.2 Input Signal Pin Assignment and Description

* Signal Connector : S13B-PH-SM3-TB (JST)

☞ Mating Connector : PHR-13

Group	Pin No.	Pin Name	Description	Note
Analog RGB	Pin 01	DB_DET	Cable Detect Pin	Internally Pull-Up (Connect this pin with DSUB #5 pin)
	Pin 02	DB_SDA	Serial Data for DDC	
	Pin 03	DB_SCL	Serial Clock for DDC	
	Pin 04	RGND	Red Ground	
	Pin 05	DB_RED	Red Data Input	
	Pin 06	GGND	Green Ground	
	Pin 07	DB_GRN	Green Data Input	
	Pin 08	BGND	Blue Ground	
	Pin 09	DB_BLU	Blue Data Input	
	Pin 10	NC	Not used	
	Pin 11	DB_VSY	Vsync Input	
	Pin 12	SGND	Sync Ground	
	Pin 13	DB_HSY	Hsync Input	

5.3 Function Key Pin Assignment and Description

* Connector type: 53261-1490 (MOLEX)

☞ Mating Connector: 51021-1490

Group	Pin No.	Pin Name	Description
Keypad	Pin 01	KVDD	Keypad Unit Power
	Pin 02	KGND 1	Keypad Unit Ground
	Pin 03	KEY8	Key Input #8
	Pin 04	KEY7	Key Input #7
	Pin 05	KEY6	Key Input #6
	Pin 06	KEY5	Key Input #5
	Pin 07	KEY4	Key Input #4
	Pin 08	KEY3	Key Input #3
	Pin 09	KEY2	Key Input #2
	Pin 10	KGND 2	Keypad Unit Ground
	Pin 11	KEY1	Key Input #1
	Pin 12	KGND 3	Keypad Unit Ground
	Pin 13	LED1	Status Indicator
	Pin 14	LED2	Status Indicator

5.4 Power Supply

5.4.1 Pin Assignment and description

*Connector type: 40006WR-02 (YeonHo Electronics)

Pin No.	Pin Name	Description	Note
1	Vin	Input Power, +12VDC (typ.)	
2	GND	Ground	

5.4.2 Input voltage & Rush current

Items	Symbol	Min.	Typ.	Max.	Unit
Input Volage	Vin	+10	+12	+15	V
Rush Current	Irush	-	-	+12	A

5.4.3 DPMS: VESA DPMS compliance

5.5 Power Consumption

5.5.1 Measurement of power consumption

☞ Normal mode (Power on): 20Watts (typ.)

SyMBER	Min.	Typ.	Max.	Unit	Condition
I in	-	+2	+2.3	A	Vin= +12V, XGA 60Hz

☞ Power saving(Stand-by, Suspend, Off mode): less than 3 watts. Monitor has to be recovered to normal operation mode within X seconds when normal signal is applied from signal source.
(TBD)

☞ Test condition : Brightness and contrast set to maximum

[White]

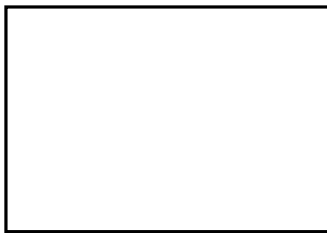

M

osaic (1 pixel on/off)]

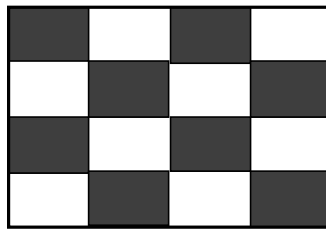

[Black]

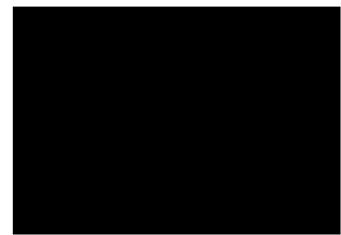

5.5.2 Power management mode: VESA DPMS protocol applied.

Mode	Horizontal sync	Vertical sync	Video signal	LED indication	Power consumption
On	Active	Active	Active	Green	TBD watts
Stand-by	Inactive	Active	Blanked	Amber	< 3 watts
Suspend	Active	Inactive	Blanked	Green/Amber blink	
Off	Inactive	Inactive	Blanked	Amber blink	

☞ RGB and Video inputs only.

5.6 Display Modes

No.	Mode	Resolution	Total	Horizontal		Vertical		Pixel Clock
				Frequency	Polarity	Frequency	Polarity	
1	VGA	720x400	900x449	31.47KHz	N	70.0 Hz	P	28.322MHz
2		640x480	800x525	31.47KHz	N	60.0 Hz	N	25.175MHz
3		640x480	864x525	35.00KHz	N	66.7 Hz	N	30.240MHz
4		640x480	832x520	37.86KHz	N	72.8 Hz	N	31.500MHz
5		640x480	840x500	37.50KHz	N	75.0 Hz	N	31.500MHz
6		640x480	832x509	43.27KHz	N	85.0 Hz	N	36.000MHz
7	SVGA	800x600	1024x625	35.16KHz	N/P	56.3 Hz	N/P	36.000MHz
8		800x600	1056x628	37.88KHz	P	60.3 Hz	P	40.000MHz
9		800x600	1040x666	48.08KHz	P	72.2 Hz	P	50.000MHz
10		800x600	1056x625	46.87KHz	P	75.0 Hz	P	49.500MHz
11		800x600	1048x631	53.67KHz	P	85.1 Hz	P	56.250MHz
12		832x624	1152x667	49.73KHz	N	74.6 Hz	N	57.284MHz
13	XGA	1024x768	1344x806	48.36KHz	N	60.0 Hz	N	65.000MHz
14		1024x768	1328x806	56.48KHz	N	70.1 Hz	N	75.000MHz
15		1024x768	1312x800	60.02KHz	P	75.0 Hz	P	78.750MHz
16		1024x768	1376x808	68.67KHz	P	85.0 Hz	P	94.500MHz
17	SXGA	1280x1024	1708x1056	64.00KHz	N	60.0 Hz	N	108.000MHz

■ 6, 11, 16, 17 mode is "Fail-safe Mode"

6. User Interface

6.1 OSD Key Matrix

※This table is based on OSD S/W presented by SAMSUNG.

If our customer wants their customized OSD, Key matrix will be changed.

Input Connector		Keypad
Pin No.	Pin Name	Function
Pin 01	KVDD	+3.3V / 100mA
Pin 02	KGND1	
Pin 03	KEY8	"AUTO"
Pin 04	KEY7	"EXIT" (Source)
Pin 05	KEY6	"LEFT"
Pin 06	KEY5	
Pin 07	KEY4	
Pin 08	KEY3	"RIGHT"
Pin 09	KEY2	"MENU"
Pin 10	KGND2	
Pin 11	KEY1	"POWER"
Pin 12	KGND3	
Pin 13	LED1	RED
Pin 14	LED2	GREEN

* Firmware(including OSD) presented by SAMSUNG is edited by SDK 2.1a

* () : Hot Key

6.2 User Controls

- * Power: Turn on and off the monitor power.
- * Menu: Calls OSD menu and select the function to be adjusted.
- * Auto: Activates "Auto adjustment is being process".
- * Exit/Source
 - ☞ Exit from the OSD function or Back to previous menu.
 - ☞ Selects input signal source by press directly without OSD menu.
- * Up/Down
 - ☞ Moves the selector up and down on the OSD menu.
- * Left/Right
 - ☞ Moves the selector left and right on the OSD menu.
 - ☞ Increase or decrease the value of selected adjustment or Select proper setting.
- * Brightness: Adjust the brightness of back light lamp by press the Left/Right buttons without OSD menu. (Hot key)
- * LED: Indicates the status of monitor operation.
 - ☞ Green: Normal
 - ☞ Black: Power OFF
 - ☞ Amber: Power saving mode or Disconnection of signal cable.

7. Microprocessor

* Mode Detection

The microprocessor has to recognize the input signal mode automatically once input signal comes from the signal source, and then has to optimize the display adjustment accordingly integrated auto adjustment procedure.

If microprocessor finds out the input mode from NVRAM, all register sets will be initialized with this latest values, but microprocessor has to optimize all register sets with pre-set values if it does not exist on NVRAM.

* Auto Adjustment

When user activates the auto adjustment function by pressing AUTO button, the microprocessor will optimize all display adjustment sets such as video offset, gain, position, phase, and frequency automatically according to pre-programmed auto adjustment program.

* Manual Adjustment

If the microprocessor does not optimize all adjustments successfully, the manual adjustment will allow the correction of image adjustment along with OSD functionality. This adjustment has to be described in the user manual correctly.

* Saving Adjustment

The microprocessor manages to save all adjustment results automatically into external NVRAM when adjustment is finished.

* Out of Range

The microprocessor has to manage all input signals to figure out the data identification. If the input signal is out of permitted frequency, the microprocessor has to protect all circuitry to avoid any electrical problem, and then has to display the warning message according to pre-programmed message like "Please re-configure the display timing of your system".

But, it will not allow to enter DPMS mode.

This system will judge the input signal as follow the below;

☞ Horizontal frequency: <28KHz, >70KHz

☞ Vertical frequency : <54Hz, >86Hz

* Display Mode (Normal and Fail-Safe mode)

If the input signal is in the permitted frequency range as below, it will be operated in normal mode.

☞ Normal mode

→ Horizontal frequency : 30-61KHz

→ Vertical frequency : 55-76Hz

But, if the input signal is higher than normal input frequency, it will be converted into FailSafe mode with gray converted image to allow reconfiguration of monitor setting using Windows control panel menu. This functionality will minimize the installation failure by end-user.

☞ FailSafe mode

> Horizontal frequency : 62-69KHz

> Vertical frequency : 77-86Hz

*** Brightness Adjustment**

The system has two kinds of brightness adjustment modes as below;

☞ Normal operation: The brightness of backlight has to be adjusted by pressing designated key.

☞ *Smart Inverter Control™*: This function allows the system to adjust the brightness of back light automatically in conjunction with the quantity of the input data

using embedded digital processing logic when this mode is activated.

User can set this mode in OSD menu.

*** Power Management**

This system's power management protocol follows VESA DPMS compliance in section of 2.5.3 "Power management", but it has to be managed along with the below horizontal and vertical frequency guide line to identify the sync signal status.

☞ Stand-by mode: Horizontal frequency < 10KHz, Vertical frequency > 40Hz, maintain more than 3 seconds.

☞ Suspend mode: Horizontal frequency > 10KHz, Vertical frequency < 40Hz, maintain more than 3 seconds.

☞ Power-off mode: Horizontal frequency < 10KHz, vertical frequency < 40Hz, maintain more than 3 seconds.

*** Factory Reset**

One designated key allows to reset all data sets into factory preset values. But, it is not allowed to get the previous user set status after this function is finished.

The system has to have this factory preset values prior to shipment to our customer.

*** DDC (EDID)**

This system has one dedicated DDC ROM on the circuitry board. The final monitor system company can installed the EDID data as refer to attachment 2 "EDID Specification" into this ROM through the serial port of VGA connector.

8. Mechanical Specification

8.1 Outline dimension

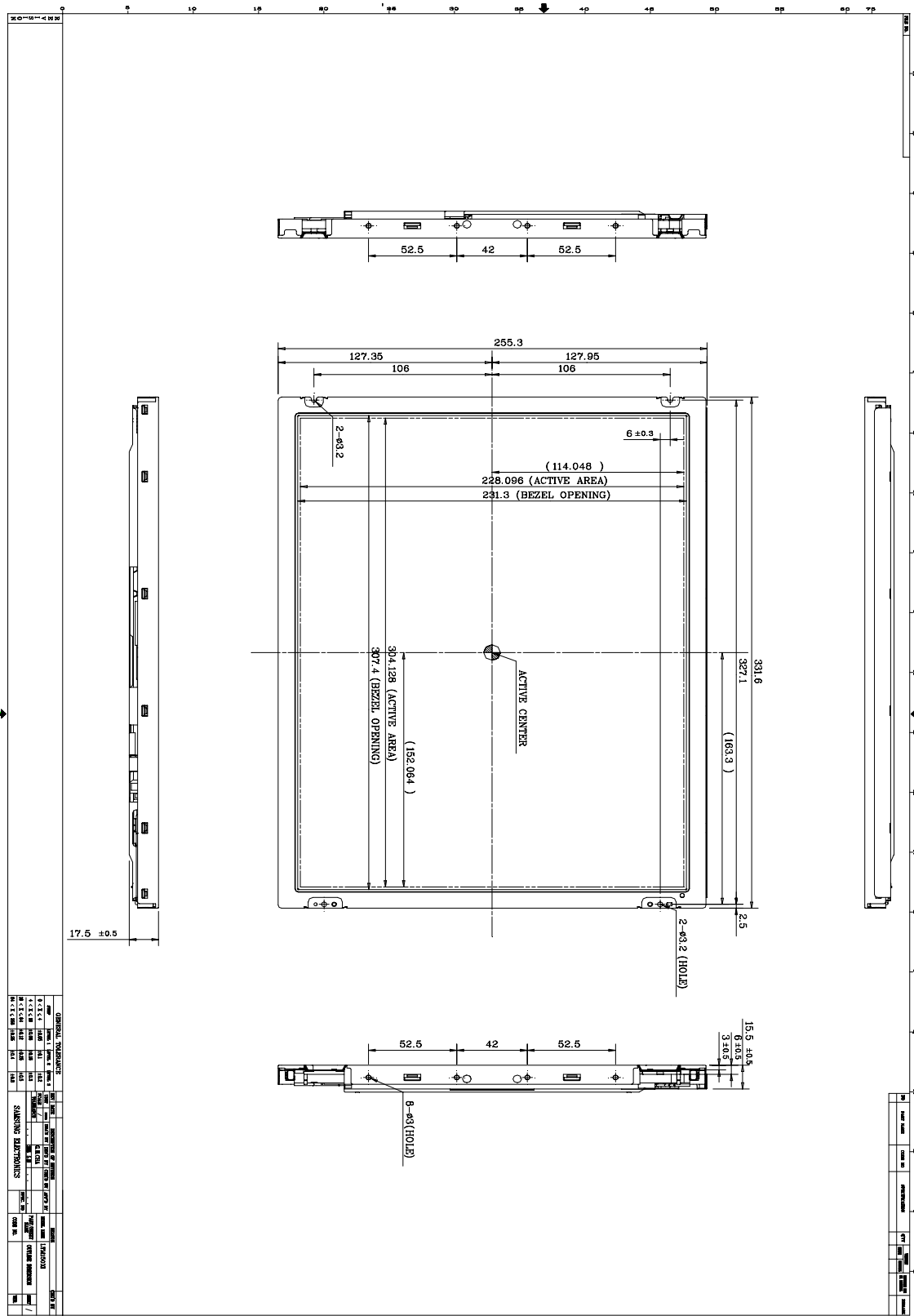

REV	DATE	DESCRIPTION	BY	CHECKED

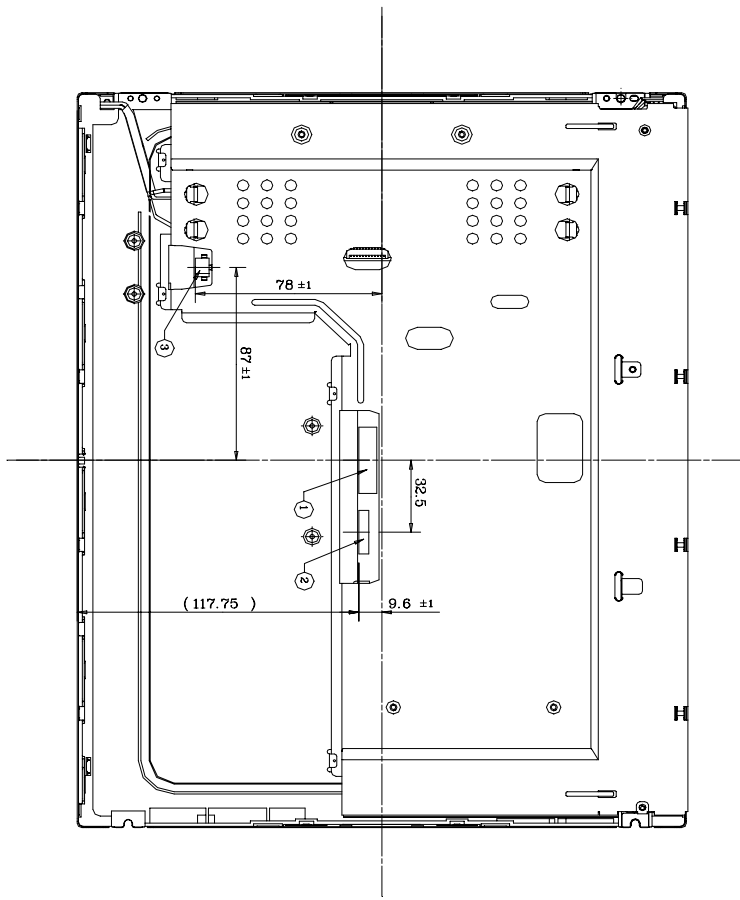

NOTE

1. NO.1 is Signal interface connector
 Maker : JST
 Part Name : S13B-PH-SM3-TB
 Mating Connector : PHR-13
2. NO.2 is Signal interface connector
 Maker : Molex
 Part Name : 53261-1490
 Mating Connector : 51021-1400
3. NO.3 is Power Connector.
 Maker : Yeonho
 Part Name : 4006WR
 Mating Connector : 40006

GENERAL TOLERANCES		DIMENSIONS OF PARTS		DIMENSIONS OF FINISH		DIMENSIONS OF MATERIAL		DIMENSIONS OF SURFACE		DIMENSIONS OF SURFACE	
UNIT	CLASS	UNIT	CLASS	UNIT	CLASS	UNIT	CLASS	UNIT	CLASS	UNIT	CLASS
mm	1	mm	1	mm	1	mm	1	mm	1	mm	1
mm	2	mm	2	mm	2	mm	2	mm	2	mm	2
mm	3	mm	3	mm	3	mm	3	mm	3	mm	3
mm	4	mm	4	mm	4	mm	4	mm	4	mm	4
mm	5	mm	5	mm	5	mm	5	mm	5	mm	5
mm	6	mm	6	mm	6	mm	6	mm	6	mm	6
mm	7	mm	7	mm	7	mm	7	mm	7	mm	7
mm	8	mm	8	mm	8	mm	8	mm	8	mm	8
mm	9	mm	9	mm	9	mm	9	mm	9	mm	9
mm	10	mm	10	mm	10	mm	10	mm	10	mm	10
mm	11	mm	11	mm	11	mm	11	mm	11	mm	11
mm	12	mm	12	mm	12	mm	12	mm	12	mm	12
mm	13	mm	13	mm	13	mm	13	mm	13	mm	13
mm	14	mm	14	mm	14	mm	14	mm	14	mm	14
mm	15	mm	15	mm	15	mm	15	mm	15	mm	15
mm	16	mm	16	mm	16	mm	16	mm	16	mm	16
mm	17	mm	17	mm	17	mm	17	mm	17	mm	17
mm	18	mm	18	mm	18	mm	18	mm	18	mm	18
mm	19	mm	19	mm	19	mm	19	mm	19	mm	19
mm	20	mm	20	mm	20	mm	20	mm	20	mm	20
mm	21	mm	21	mm	21	mm	21	mm	21	mm	21
mm	22	mm	22	mm	22	mm	22	mm	22	mm	22
mm	23	mm	23	mm	23	mm	23	mm	23	mm	23
mm	24	mm	24	mm	24	mm	24	mm	24	mm	24
mm	25	mm	25	mm	25	mm	25	mm	25	mm	25
mm	26	mm	26	mm	26	mm	26	mm	26	mm	26
mm	27	mm	27	mm	27	mm	27	mm	27	mm	27
mm	28	mm	28	mm	28	mm	28	mm	28	mm	28
mm	29	mm	29	mm	29	mm	29	mm	29	mm	29
mm	30	mm	30	mm	30	mm	30	mm	30	mm	30
mm	31	mm	31	mm	31	mm	31	mm	31	mm	31
mm	32	mm	32	mm	32	mm	32	mm	32	mm	32
mm	33	mm	33	mm	33	mm	33	mm	33	mm	33
mm	34	mm	34	mm	34	mm	34	mm	34	mm	34
mm	35	mm	35	mm	35	mm	35	mm	35	mm	35
mm	36	mm	36	mm	36	mm	36	mm	36	mm	36
mm	37	mm	37	mm	37	mm	37	mm	37	mm	37
mm	38	mm	38	mm	38	mm	38	mm	38	mm	38
mm	39	mm	39	mm	39	mm	39	mm	39	mm	39
mm	40	mm	40	mm	40	mm	40	mm	40	mm	40
mm	41	mm	41	mm	41	mm	41	mm	41	mm	41
mm	42	mm	42	mm	42	mm	42	mm	42	mm	42
mm	43	mm	43	mm	43	mm	43	mm	43	mm	43
mm	44	mm	44	mm	44	mm	44	mm	44	mm	44
mm	45	mm	45	mm	45	mm	45	mm	45	mm	45
mm	46	mm	46	mm	46	mm	46	mm	46	mm	46
mm	47	mm	47	mm	47	mm	47	mm	47	mm	47
mm	48	mm	48	mm	48	mm	48	mm	48	mm	48
mm	49	mm	49	mm	49	mm	49	mm	49	mm	49
mm	50	mm	50	mm	50	mm	50	mm	50	mm	50
mm	51	mm	51	mm	51	mm	51	mm	51	mm	51
mm	52	mm	52	mm	52	mm	52	mm	52	mm	52
mm	53	mm	53	mm	53	mm	53	mm	53	mm	53
mm	54	mm	54	mm	54	mm	54	mm	54	mm	54
mm	55	mm	55	mm	55	mm	55	mm	55	mm	55
mm	56	mm	56	mm	56	mm	56	mm	56	mm	56
mm	57	mm	57	mm	57	mm	57	mm	57	mm	57
mm	58	mm	58	mm	58	mm	58	mm	58	mm	58
mm	59	mm	59	mm	59	mm	59	mm	59	mm	59
mm	60	mm	60	mm	60	mm	60	mm	60	mm	60
mm	61	mm	61	mm	61	mm	61	mm	61	mm	61
mm	62	mm	62	mm	62	mm	62	mm	62	mm	62
mm	63	mm	63	mm	63	mm	63	mm	63	mm	63
mm	64	mm	64	mm	64	mm	64	mm	64	mm	64
mm	65	mm	65	mm	65	mm	65	mm	65	mm	65
mm	66	mm	66	mm	66	mm	66	mm	66	mm	66
mm	67	mm	67	mm	67	mm	67	mm	67	mm	67
mm	68	mm	68	mm	68	mm	68	mm	68	mm	68
mm	69	mm	69	mm	69	mm	69	mm	69	mm	69
mm	70	mm	70	mm	70	mm	70	mm	70	mm	70
mm	71	mm	71	mm	71	mm	71	mm	71	mm	71
mm	72	mm	72	mm	72	mm	72	mm	72	mm	72
mm	73	mm	73	mm	73	mm	73	mm	73	mm	73
mm	74	mm	74	mm	74	mm	74	mm	74	mm	74
mm	75	mm	75	mm	75	mm	75	mm	75	mm	75
mm	76	mm	76	mm	76	mm	76	mm	76	mm	76
mm	77	mm	77	mm	77	mm	77	mm	77	mm	77
mm	78	mm	78	mm	78	mm	78	mm	78	mm	78
mm	79	mm	79	mm	79	mm	79	mm	79	mm	79
mm	80	mm	80	mm	80	mm	80	mm	80	mm	80
mm	81	mm	81	mm	81	mm	81	mm	81	mm	81
mm	82	mm	82	mm	82	mm	82	mm	82	mm	82
mm	83	mm	83	mm	83	mm	83	mm	83	mm	83
mm	84	mm	84	mm	84	mm	84	mm	84	mm	84
mm	85	mm	85	mm	85	mm	85	mm	85	mm	85
mm	86	mm	86	mm	86	mm	86	mm	86	mm	86
mm	87	mm	87	mm	87	mm	87	mm	87	mm	87
mm	88	mm	88	mm	88	mm	88	mm	88	mm	88
mm	89	mm	89	mm	89	mm	89	mm	89	mm	89
mm	90	mm	90	mm	90	mm	90	mm	90	mm	90
mm	91	mm	91	mm	91	mm	91	mm	91	mm	91
mm	92	mm	92	mm	92	mm	92	mm	92	mm	92
mm	93	mm	93	mm	93	mm	93	mm	93	mm	93
mm	94	mm	94	mm	94	mm	94	mm	94	mm	94
mm	95	mm	95	mm	95	mm	95	mm	95	mm	95
mm	96	mm	96	mm	96	mm	96	mm	96	mm	96
mm	97	mm	97	mm	97	mm	97	mm	97	mm	97
mm	98	mm	98	mm	98	mm	98	mm	98	mm	98
mm	99	mm	99	mm	99	mm	99	mm	99	mm	99
mm	100	mm	100	mm	100	mm	100	mm	100	mm	100

8.2 Packing Information

8.2.1 Carton (Internal Package)

8.2.1.1 Packing Form: Corrugated fiberboard box and corrugated cardboard as shock absorber.

8.2.1.2 Packing Method

- NOTE 1) Acceptance number of piling : 10sets
2) Carton size :450(W) X 348(D) X 440(H)
3) MAX accumulation quantity : 4 cartons

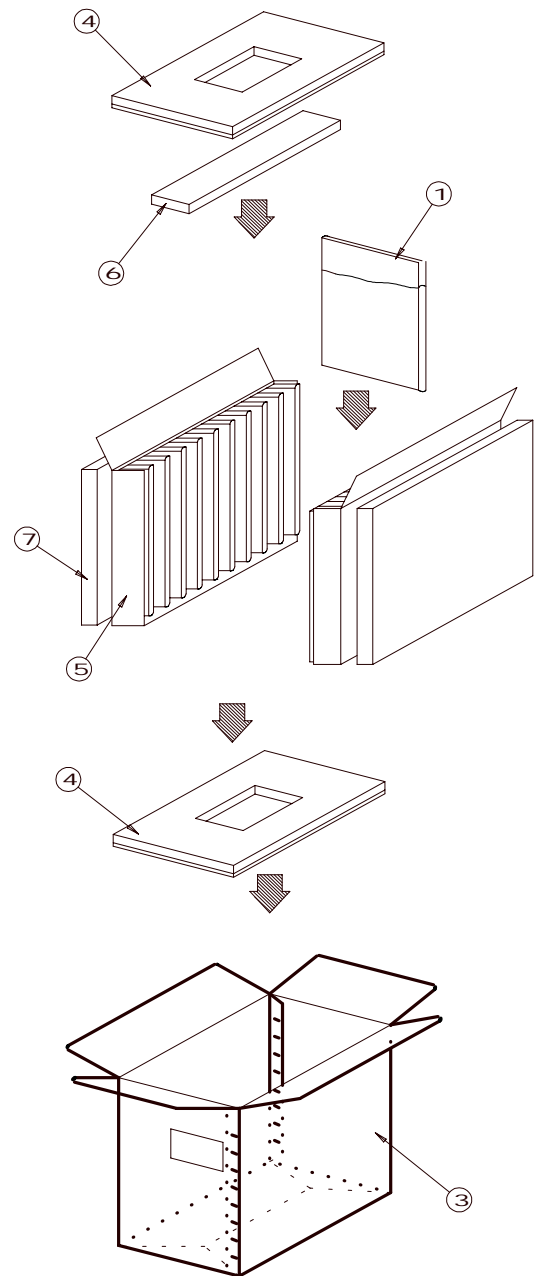
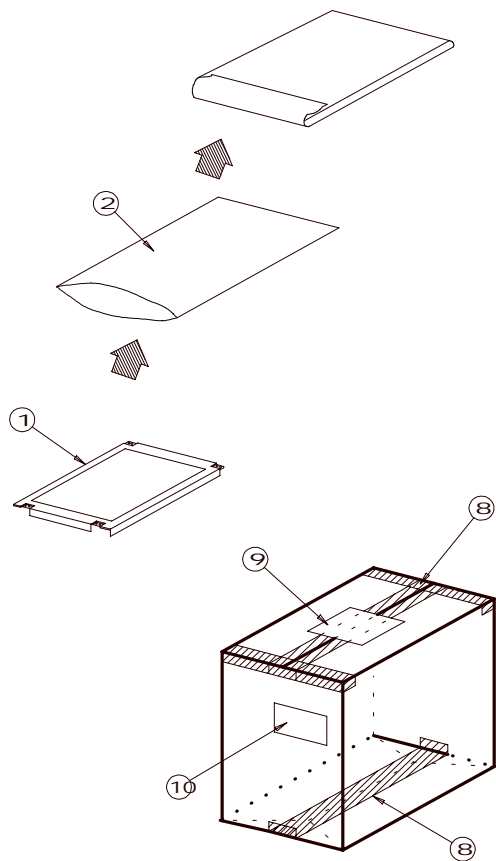
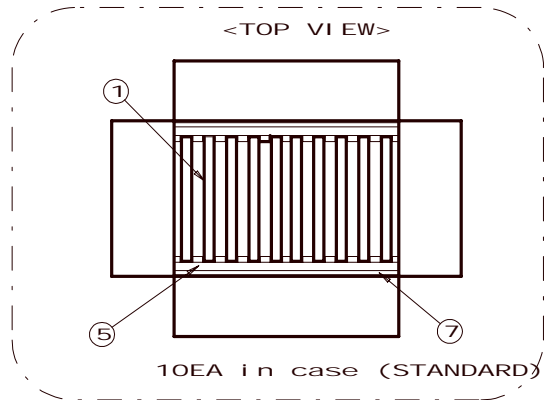

8.2.1.3 Unless LCD Module are 10ea at one packing_case

* Unless LCD module are 10EA at one packing-case.

- > 1) Put in some LCD module in the direction of one.
 2) Try addition PAD CUSHION(2EA) in the next position.

ex) LCD module are 5EA in case.

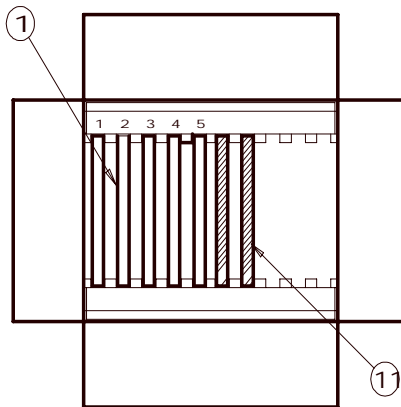

* PAD CUSHION size
 (LT140X1/LTM150XS MODEL)
 : 250(W) x 330(H) x 20(T)

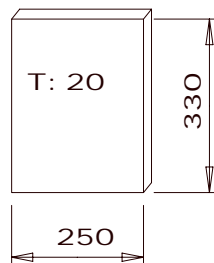

8.2.1.4 Packing Material

No	Part name	Quality
1	Static electric protective sack	10
2	Packing case(Inner box) included shock absorber	1 set
3	Pictorial marking	2 pcs
4	Carton	1 set

9. GENERAL PRECAUTION

9.1 Handling

- ☞ When the module is assembled, It should be attached to the system firmly using every mounting holes. Be careful not to twist and bend the modules.
- ☞ Refrain from strong mechanical shock and / or any force to the module. In addition to damage, this may cause improper operation or damage to the module and CCFT back-light.
- ☞ Note that polarizers are very fragile and could be easily damaged. Do not press or scratch the surface harder than a HB pencil lead.
- ☞ Wipe off water droplets or oil immediately. If you leave the droplets for a long time, Staining and discoloration may occur.
- ☞ If the surface of the polarizer is dirty, clean it using some absorbent cotton or soft cloth.
- ☞ The desirable cleaners are water, IPA(Isopropyl Alcohol) or Hexane. Do not use Ketone type materials (ex. Acetone), Ethyl alcohol, Toluene, Ethyl acid or Methyl chloride. It might permanent damage to the polarizer due to chemical reaction.
- ☞ If the liquid crystal material leaks from the panel, it should be kept away from the eyes or mouth . In case of contact with hands, legs or clothes, it must be washed away thoroughly with soap.
- ☞ Protect the module from static , it may cause damage to the CMOS Gate Array IC.
- ☞ Use finger-stalls with soft gloves in order to keep display clean during the incoming inspection and assembly process.
- ☞ Do not disassemble the module.
- ☞ Do not pull or fold the lamp wire.
- ☞ Do not adjust the variable resistor which is located on the back side.
- ☞ Pins of I/F connector shall not be touched directly with bare hands.

9.2 Storage

- ☞ Do not leave the module in high temperature, and high humidity for a long time.
- ☞ It is highly recommended to store the module with temperature from 0°C to 35°C and relative humidity of less than 70%.
- ☞ Do not store the TFT-LCD module in direct sunlight.
- ☞ The module shall be stored in a dark place. It is prohibited to apply sunlight or fluorescent light during the store.

9.3 Operation

- ☞ Do not connect,disconnect the module in the Power On condition.
- ☞ Power supply should always be turned on/off by the item 6.5 ? Power on/off sequence?
 - ☞ Module has high frequency circuits. Sufficient suppression to the electromagnetic interference shall be done by system manufacturers. Grounding and shielding methods may

be important to minimize the interference.

- ☞ The cable between the back-light connector and its inverter power supply shall be a minimized length and be connected directly. The longer cable between the back-light and the inverter may cause lower luminance of lamp(CCFT) and may require higher startup voltage(Vs).

9.4 Others

- ☞ Ultra-violet ray filter is necessary for outdoor operation.
- ☞ Avoid condensation of water. It may result in improper operation or disconnection of electrode.
- ☞ Do not exceed the absolute maximum rating value. (the supply voltage variation, input voltage variation, variation in part contents and environmental temperature, so on) Otherwise the module may be damaged.
- ☞ If the module displays the same pattern continuously for a long period of time, it can be the situation when the image Sticks to the screen.
- ☞ This module has its circuitry PCB on the rear side and should be handled carefully in order not to be stressed.

Appendix 1: Timing Table of Display modes

Originator		IBM	IBM	MAC	VESA	VESA	VESA ^{*1}	VESA	VESA
H-Resolution	Pixels	720	640	640	640	640	640	800	800
V-resolution	Lines	400	480	480	480	480	480	600	600
H Frequency	KHz	31.469	31.469	35.000	37.861	37.500	43.269	35.156	37.879
V Frequency	Hz	70.087	59.940	66.667	72.809	75.000	85.008	56.250	60.317
Scan Type	-	NI	NI	NI	NI	NI	NI	NI	NI
H Sync Polarity	-	N	N	N	N	N	N	N or P	P
V Sync Polarity	-	P	N	N	N	N	N	N or P	P
Pixel Frequency	MHz	28.322	25.275	30.240	31.500	31.500	36.000	36.000	40.000
H Active	Pixels	720	640	640	640	640	640	800	800
H Right Border	Pixels	9	8	0	8	0	0	0	0
H Front Porch	Pixels	9	8	64	16	16	56	24	40
H Sync	Pixels	108	96	64	40	64	56	72	128
H Back Porch	Pixels	45	40	96	120	120	80	128	88
H Left Border	Pixels	9	8	0	8	0	0	0	0
H Total	Pixels	900	800	864	832	840	832	1024	1056
V Active	Lines	400	480	480	480	480	480	600	600
V Right Border	Lines	7	8	0	8	0	0	0	0
V Front Porch	Lines	6	2	3	1	1	1	1	1
V Sync	Lines	2	2	3	3	3	3	2	4
V Back Porch	Lines	27	25	39	20	16	25	22	23
V Left Border	Lines	7	8	0	8	0	0	0	0
V Total	Lines	449	525	525	520	500	509	625	628

Originator		VESA	VESA	VESA ^{*1}	VESA	VESA	VESA	VESA ^{*1}	VESA ^{*2}
H-Resolution	Pixels	800	800	800	1024	1024	1024	1024	1280
V-resolution	Lines	600	600	600	768	768	768	768	1024
H Frequency	KHz	48.077	46.875	53.674	48.363	56.476	60.023	68.677	63.981
V Frequency	Hz	72.188	75.000	85.061	60.004	70.069	75.029	84.997	60.020
Scan Type	-	NI	NI	NI	NI	NI	NI	NI	NI
H Sync Polarity	-	P	P	P	N	N	P	P	P
V Sync Polarity	-	P	P	P	N	N	P	P	P
Pixel Frequency	MHz	50.000	49.500	56.250	65.000	75.000	78.750	94.500	108.000
H Active	Pixels	800	800	800	1024	1024	1024	1024	1280
H Right Border	Pixels	0	0	0	0	0	0	0	0
H Front Porch	Pixels	56	16	32	24	24	16	48	48
H Sync	Pixels	120	80	64	136	136	96	96	112
H Back Porch	Pixels	64	160	152	160	144	176	208	248
H Left Border	Pixels	0	0	0	0	0	0	0	0
H Total	Pixels	1040	1056	1048	1344	1328	1312	1376	1688
V Active	Lines	600	600	600	768	768	768	768	1024
V Right Border	Lines	0	0	0	0	0	0	0	0
V Front Porch	Lines	37	1	1	3	3	1	1	1
V Sync	Lines	6	3	3	6	6	3	3	3
V Back Porch	Lines	23	21	27	29	29	28	36	38
V Left Border	Lines	0	0	0	0	0	0	0	0
V Total	Lines	666	625	631	806	806	800	808	1066

※1: FailSafe mode, 2: Down scaling mode

Appendix 2: EDID Specification (DDC Data Structure)

This specification is for identifying the system specification and characteristics to get the right values of each EDID item. The final system company has to right down this EDID data into designated DDC ROM through serial data line of VGA connector as refer to the below descriptions.

Basic Product Information		Established Timing		Standard Timing	Detail Timing
Manufacturing	Blanked(TBD) ^{*1}	720x400@70Hz	○	1024x768@85Hz	1024x768@60Hz
Product code	Blanked(TBD) ^{*1}	720x400@88Hz	×	800x600@85Hz	[RangeLimit] Vt: 56-85Hz Ht:30KHz-69KHz Max clock: 100MHz
Serial No.	Blanked(TBD) ^{*1}	640x480@60Hz	○	640x480@85Hz	
Week mfg	Blanked(TBD) ^{*1}	640x480@67Hz	○		
Year mfg	Blanked(TBD) ^{*1}	640x480@72Hz	○		
EDID Version	Blanked(TBD) ^{*1}	640x480@75Hz	○		[Monitor Name] Blanked(TBD) ^{*1}
EDID Revision	Blanked(TBD) ^{*1}	800x600@56Hz	○		[Serial #] Blanked(TBD) ^{*1}
Video input	Analog RGB Color	800x600@60Hz	○		
Signal level	0.7V/0.3V	800x600@72Hz	○		
Sync. type	Sep, Comp, SOG	800x600@75Hz	○		
Serration	Yes	1024x768@87Hz(i)	×		
Blank Level	No	1024x768@60Hz	○		
H-size(cm)		1024x768@70Hz	○		
V-size(cm)		1024x768@75Hz	○		
Gamma		1280x1024@60Hz	○		
DPMS Support	Yes				
Red Color(x,y)					
Green Color(x,y)					
Blue Color(x,y)					
White Color(x,y)					

※Every blanked item has to be filled up by final system company.