

SPEC No. LD-16503A

ISSUE : May. 25. 04

PAGE: 22 pages

DEVICE SPECIFICATION FOR

TFT-LCD Module

MODEL No.

LQ0DZA0051

The device listed in these specification sheets was designed and manufactured for use in OA equipment.

In case of using the device for applications such as control and safety equipment for transportation(aircraft, trains, automobiles, etc.), rescue and security equipment and various safety related equipment which require higher reliability and safety, take into consideration that appropriate measures such as fail-safe functions and redundant system design should be taken.

Do not use the device for equipment that requires an extreme level of reliability, such as aerospace applications, telecommunication equipment(trunk lines), nuclear power control equipment and medical or other equipment for life support.

This specification sheet is to guarantee the quality of the LCD module itself, only. Should you need to evaluate and confirm the performance of the module, please do so when the LCD module is assembled into your finished product.

Table of contents

1. Application	3
2. Overview	3
3. Mechanical Specifications	3
4. Input Terminals	4
4-1. TFT-LCD panel driving	4
4-2 Interface block diagram	5
4-3. Backlight driving	6
5. Absolute Maximum Ratings	6
6. Electrical Characteristics	6
6-1. TFT-LCD panel driving	6
6-2. Backlight driving	8
6-3. LVDS Input Specification	9
6.3.1. Switching Characteristics	9
6.3.2. LVDS Data Input Timing	10
7. Timing characteristics of input signals	11
7-1. Timing characteristics	11
7-2. Input Data Signals and Display Position on the screen	12
8. Input Signals, Basic Display Colors and Gray Scale of Each Color	13
9. Optical Characteristics	14
10. Display Quality	15
11. Handling Precautions	16
12. Packing form	16
13. Reliability test items	17
14. Label	18
Fig.1 Packing Form	19
Fig.2 Outline dimensions	20

1. Application

This specification applies to a color TFT-LCD module, LQ0DZA0051.

2. Overview

This module is a color active matrix LCD module incorporating amorphous silicon TFT (Thin Film Transistor). It is composed of a color TFT-LCD panel, driver ICs, control circuit and power supply circuit and a backlight unit. Graphics and texts can be displayed on a $1920 \times 3 \times 1200$ dots panel with 262,144 colors by using LVDS (Low Voltage Differential Signaling) to interface and supplying +3.3V DC supply voltage for TFT-LCD panel driving and supply voltage for backlight.

Backlight-driving DC/AC inverter is not built in this module.

3. Mechanical Specifications

Parameter	Specifications	Unit
Display size	43 (17.0") Diagonal	cm
Active area	365.76 (H) × 228.60 (V)	mm
Pixel format	1920 (H) × 1200 (V)	pixel
	(1 pixel = R+G+B dots)	
Aspect ratio	16 : 10	
Pixel pitch	0.1905 (H) × 0.1905 (V)	mm
Pixel configuration	R,G,B vertical stripe	
Display mode	Normally white	
Surface treatment	Glare and hard-coating 2H	
	Low reflection	

Parameter		Min.	Typ.	Max.	Unit
Unit outline dimensions [Note 1]	Width	381.7	382.2	382.7	mm
	Height	246.3	246.8	247.3	mm
	Depth	—	—	10.3	mm
Mass		—	1000	1040	g

[Note 1] excluding backlight cables.

Outline dimensions is shown in Fig.2

4. Input Terminals

4-1. TFT-LCD panel driving

CN1 (LVDS signals and +3.3V DC power supply)

Pin No.	Symbol	Function	Remark
1	GND		
2	Vcc	+3.3V power supply	
3	Vcc	+3.3V power supply	
4	GND		
5	GND		
6	GND		
7	GND		
8	R1IN0-	Receiver signal of A side pixel (-)	[Note 1]
9	R1IN0+	Receiver signal of A side pixel (+)	[Note 1]
10	GND		
11	R1IN1-	Receiver signal of A side pixel (-)	[Note 1]
12	R1IN1+	Receiver signal of A side pixel (+)	[Note 1]
13	GND		
14	R1IN2-	Receiver signal of A side pixel (-)	[Note 1]
15	R1IN2+	Receiver signal of A side pixel (+)	[Note 1]
16	GND		
17	CK1 IN-	Clock signal of A side pixel (-)	[Note 1]
18	CK1 IN+	Clock signal of A side pixel (+)	[Note 1]
19	GND		
20	R2IN0-	Receiver signal of B side pixel (-)	[Note 1]
21	R2IN0+	Receiver signal of B side pixel (+)	[Note 1]
22	GND		
23	R2IN0-	Receiver signal of B side pixel (-)	[Note 1]
24	R2IN0+	Receiver signal of B side pixel (+)	[Note 1]
25	GND		
26	R2IN0-	Receiver signal of B side pixel (-)	[Note 1]
27	R2IN0+	Receiver signal of B side pixel (+)	[Note 1]
28	GND		
29	CK2 IN-	Clock signal of B side pixel (-)	[Note 1]
30	CK2 IN+	Clock signal of B side pixel (+)	[Note 1]

[Note 1] Relation between LVDS signals and actual data is shown in following section (4-2)(7-2).

[Note 2] The shielding case is connected with signal GND.

4-2 Interface block diagram

Using receiver : Dual LVDS interface contained in a control IC
 Corresponding Transmitter : THC63LVDM63A (THINE) or equivalent

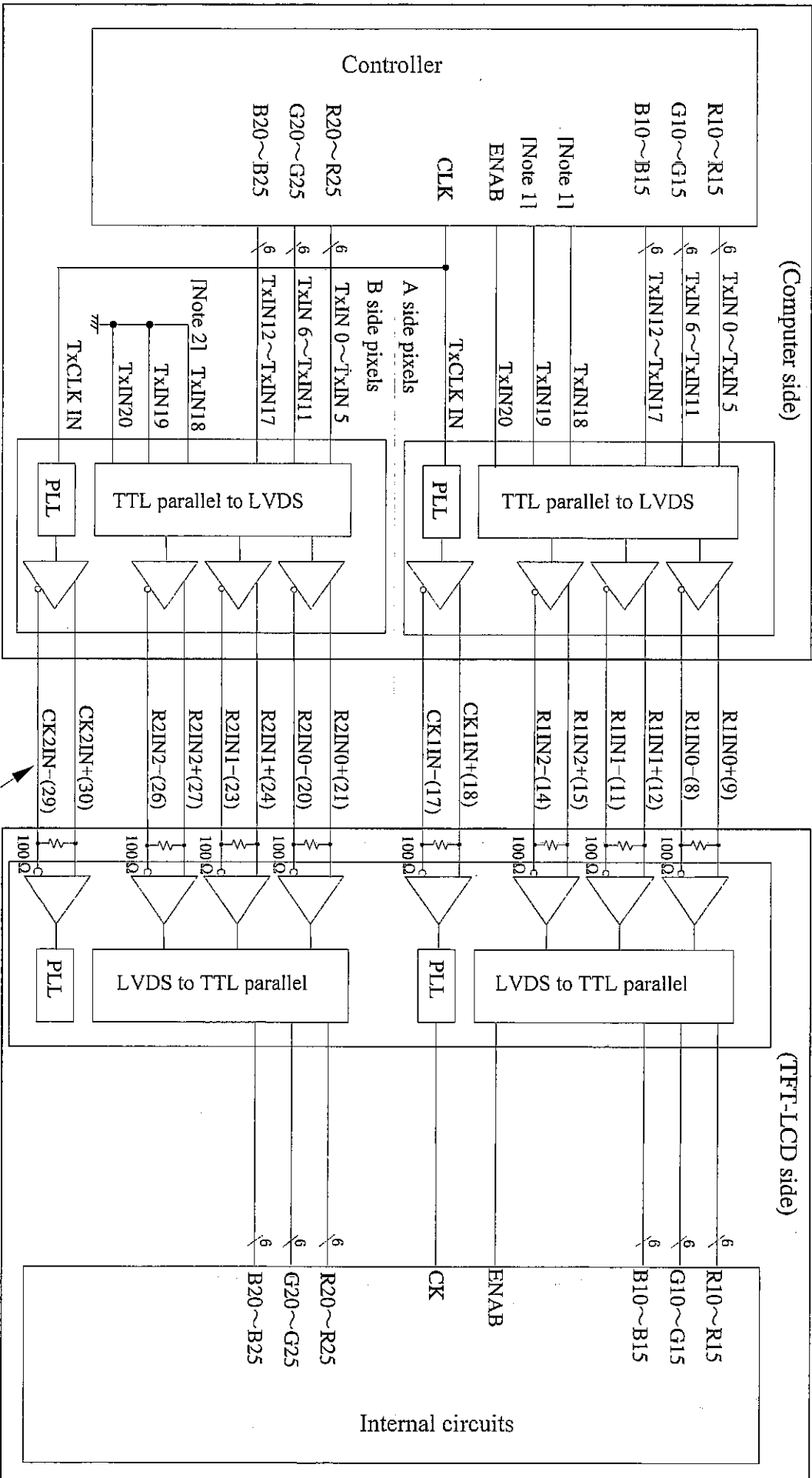

[Note 1] Do not use at high-impedance for pixels on A side's TxIN 18 - 19.
 [Note 2] Please connect B side pixels, TxIN 18 - 19 to GND.

Symbol of CN1 (Pin No.)

4-3. Backlight driving

CN2,CN3 Using connector:BHSR-02VS-1(JST)

Mating connector : SM02B-BHSS-1-TB(JST)

Connector No.	Pin No.	Symbol	Function	FL cable color
CN2	1	V _{High}	Power supply for lamp (High voltage side)	Pink
	2	V _{Low}	Power supply for lamp (Low voltage side)	White
CN3	1	V _{High}	Power supply for lamp (High voltage side)	Blue
	2	V _{Low}	Power supply for lamp (Low voltage side)	Black

5. Absolute Maximum Ratings

Parameter	Symbol	Condition	Ratings		Unit	Remark
			Min.	Max.		
Input voltage	V _I	Ta=+25°C	-0.3	V _{CC} +0.3	V	[Note 1]
+3.3V supply voltage	V _{CC}	Ta=+25°C	0	+4.0	V	
Storage temperature	T _{stg}	—	-25	+60	°C	[Note 2]
Operating temperature (Ambient)	T _{opa}	—	0	+45	°C	

[Note 1] LVDS signals

[Note 2] Humidity : 95%RH Max. at Ta ≤ +40°C.

Maximum wet-bulb temperature at +39°C or less at Ta > +40°C.

No condensation.

6. Electrical Characteristics

6-1. TFT-LCD panel driving

Ta = +25°C

Parameter	Symbol	Min.	Typ.	Max.	Unit	Remark
Supply voltage	V _{CC}	+3.0	+3.3	+3.6	V	[Note 2]
Current dissipation	I _{CC}	—	710	950	mA	[Note 3]
Permissible input ripple voltage	V _{RP}	—	—	100	mV _{P-P}	V _{CC} = +3.3V
Input voltage range	V _I	0	—	2.4	V	LVDS signals
Differential input threshold voltage	High	V _{TH}	—	+100	mV	V _{CM} = +1.2V [Note 1]
	Low	V _{TL}	-100	—	mV	
Input current (High)	I _{OH}	—	—	±10	μA	V _I = +2.4V V _{CC} = +3.6V
Input current (Low)	I _{OL}	—	—	±10	μA	V _I = 0V V _{CC} = 3.6V
Terminal resistor	R _T	—	100	—	Ω	Differential input

[Note 1] V_{CM} : Common mode voltage of LVDS driver.

[Note 2]

On-off conditions for supply voltage

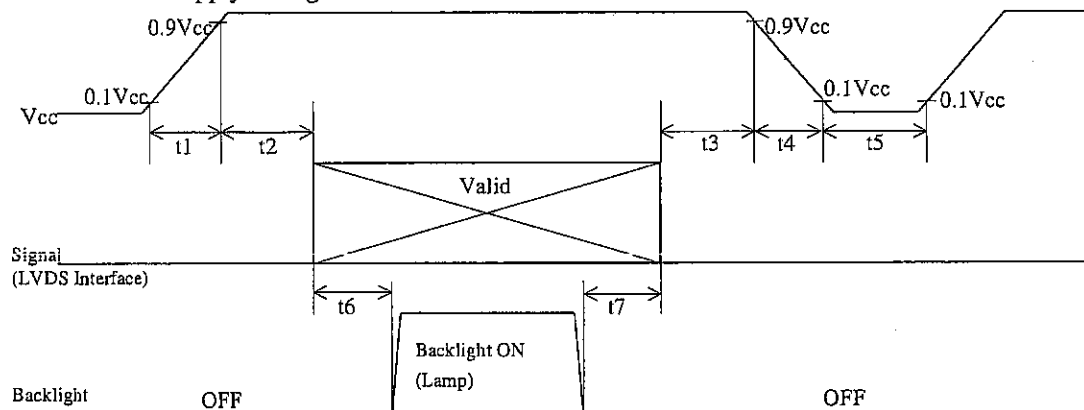

Symbol	Min.	Max.	Unit	Remark
t1	0	10	ms	
t2	0	1	s	
t3	0	1	s	
t4	0	400	ms	
t5	200	—	ms	
t6	180	—	ms	*1
t7	5	—	ms	*1

*1 : As for the power sequence for backlight, it is recommended to apply above mentioned input timing. If the backlight is lit on and off at a timing other than shown above, displaying image may get disturbed. This is due to variation of output signal from timing generator when LVDS signal is changed from on to off or vice versa, but has no harm to the module itself.

[Note] Do not keep the interface signal high-impedance or unusual signal when power is on.

Vcc-dip conditions

- 1) $2.5\text{ V} \leq V_{cc} < 3.0\text{ V}$
 $t_d \leq 10\text{ ms}$

Under above condition, the display image should return to an appropriate figure after Vcc voltage recovers.

- 2) $V_{cc} < 2.5\text{ V}$

Vcc-dip conditions should also follow the On-off conditions for supply voltage

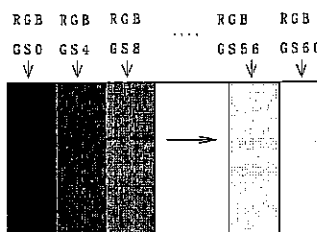
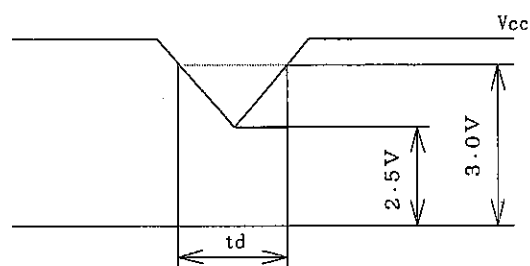

[Note 3] Typical current situation : 16-gray-bar pattern.

Vcc=+3.3V

6-2. Backlight driving

The backlight system is edge-lighting type with two CCFTs (Cold Cathode Fluorescent Tube).

The characteristics of one lamp are shown in the following table.

Parameter	Symbol	Min.	Typ.	Max.	Unit	Remark
Lamp current range	I_L	2.0	6.0	6.5	mArms	[Note 1]
Lamp voltage	V_L	—	825	—	V _{rms}	
Lamp power consumption	P_L	—	4.95	—	W	[Note 2]
Lamp frequency	F_L	42	58	80	kHz	[Note 3]
Kick-off voltage	V_s	—	—	1750	V _{rms}	Ta=25°C
		—	—	1900	V _{rms}	Ta=0°C [Note 4]
Lamp life time	L_L	10000	—	—	Hour	[Note 5]

[Note 1] The lamp current range which can be turned on is shown.

Lamp current measures by connecting the ammeter for high frequency to the V_{Low} side in the circuit of the following figure.

- Lamp frequency : 42~80kHz
- Temperature (Ambient) : 0~45°C

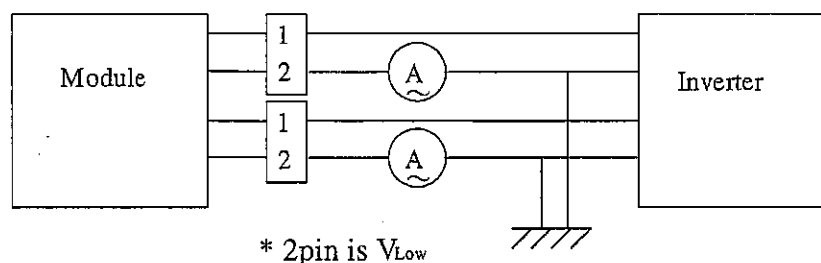

In addition, please check lighting starting nature and lighting stability after mounting a module and an inverter on the occasion of use in a low current region.

[Note 2] Calculated value for reference ($I_L \times V_L$)

[Note 3] Lamp frequency may produce interference with horizontal synchronous frequency, and this may cause beat on the display. Therefore lamp frequency shall be detached as much as possible from the horizontal synchronous frequency and from the harmonics of horizontal synchronous to avoid interference.

[Note 4] It is defined at 22pF for the ballast capacitor of a DC/AC inverter.

The voltage above this value should be applied to the lamp for more than 1 second to start-up. Otherwise the lamp may not be turned on.

[Note 5] Above value is applicable when the long side of LCD module is placed horizontally.(Landscape position)
(Lamp lifetime may vary if LCD module is in portrait position due to the change of mercury density inside the lamp)

Lamp life time is defined as the time when either ① or ② occurs in the continuous operation under the condition of Ta = 25°C and I_L = 6.0 mArms.

- ① Brightness becomes 50 % of the original value under standard condition.
- ② Kick-off voltage at Ta = 0°C exceeds maximum value, 1900 V rms.

[Note] The performance of the backlight, for example life time or brightness, is much influenced by the characteristics of the DC-AC inverter for the lamp.

When you design or order the inverter, please make sure that a poor lighting caused by the mismatch of the backlight and the inverter (miss-lighting, flicker, etc.) never occur.

When you confirm it, the module should be operated in the same condition as it is installed in your instrument.

[Note] Insulate the high voltage area in order to prevent direct contacts to the area. As countermeasures for excessive heat or exothermic fire, use protection elements such as fuses to cut the circuit.

Use burn-resistant (or noncombustible) material for board or resin.

6-3. LVDS Input Specification

6.3.1. Switching Characteristics

$V_{cc}=+3.0V \sim +3.6V$, $T_a=0^{\circ}C \sim +45^{\circ}C$

Parameter	Symbol	Min	Typ.	Max.	Unit
Input Data Position 0 ($t_{RCIP}=18.52ns$)	t_{RIP1}	-0.25	0.0	+0.25	ns
Input Data Position 1 ($t_{RCIP}=18.52ns$)	t_{RIP0}	$t_{RCIP}/7-0.25$	$t_{RCIP}/7$	$t_{RCIP}/7+0.25$	ns
Input Data Position 2 ($t_{RCIP}=18.52ns$)	t_{RIP6}	$2 t_{RCIP}/7-0.25$	$2 t_{RCIP}/7$	$2 t_{RCIP}/7+0.25$	ns
Input Data Position 3 ($t_{RCIP}=18.52ns$)	t_{RIP5}	$3 t_{RCIP}/7-0.25$	$3 t_{RCIP}/7$	$3 t_{RCIP}/7+0.25$	ns
Input Data Position 4 ($t_{RCIP}=18.52ns$)	t_{RIP4}	$4 t_{RCIP}/7-0.25$	$4 t_{RCIP}/7$	$4 t_{RCIP}/7+0.25$	ns
Input Data Position 5 ($t_{RCIP}=18.52ns$)	t_{RIP3}	$5 t_{RCIP}/7-0.25$	$5 t_{RCIP}/7$	$5 t_{RCIP}/7+0.25$	ns
Input Data Position 6 ($t_{RCIP}=18.52ns$)	t_{RIP2}	$6 t_{RCIP}/7-0.25$	$6 t_{RCIP}/7$	$6 t_{RCIP}/7+0.25$	ns
Phase Lock Loop Set	t_{RPLL}			10	ms
Input Clock Period	t_{RCIP}	17.8	18.5	25	ns
Skew Time between CK1IN and CK2IN	t_{CK12}	-2.0	0.0	+2.0	ns

AC Timing Diagrams LVDS Inputs

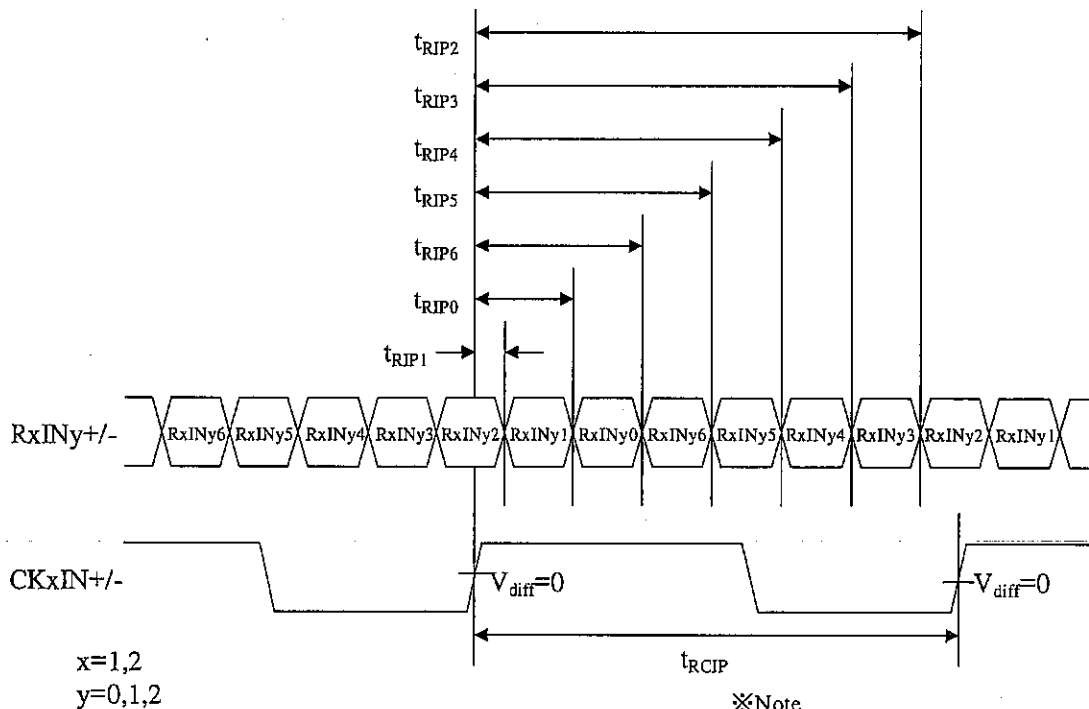

※Note

$V_{diff}=(RxINy+)-(RxINy-)$, $(CKxIN+)-(CKxIN-)$

AC Timing Diagrams LVDS Input CLK Skew

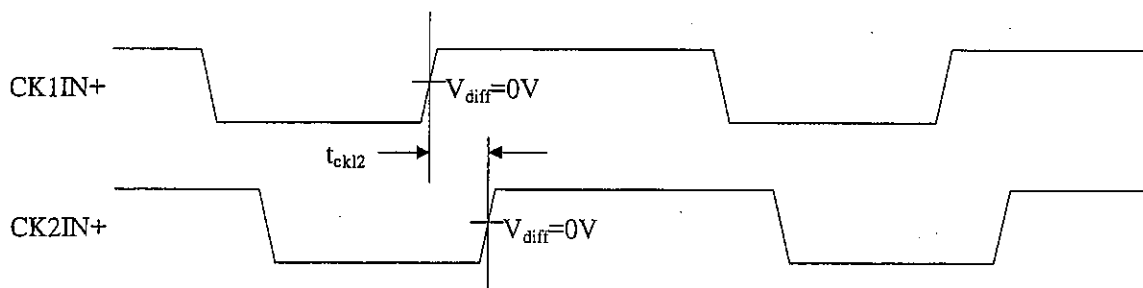

LVDS Phase Lock Loop Set

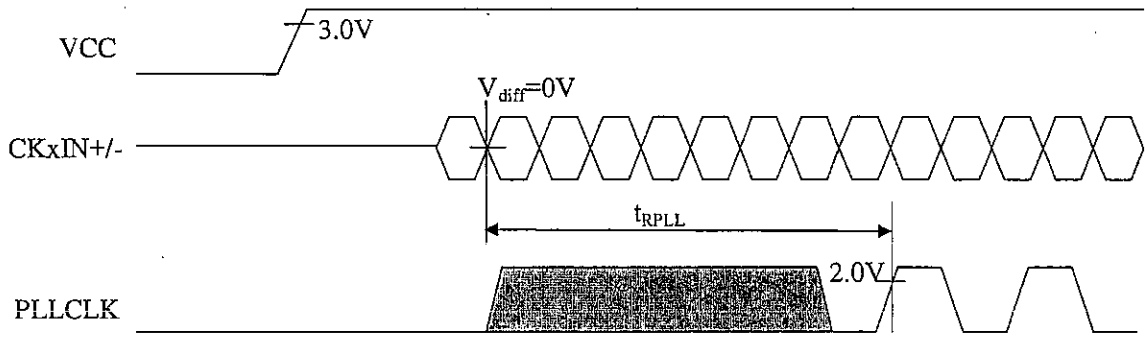

6.3.2.LVDS Data Input Timing

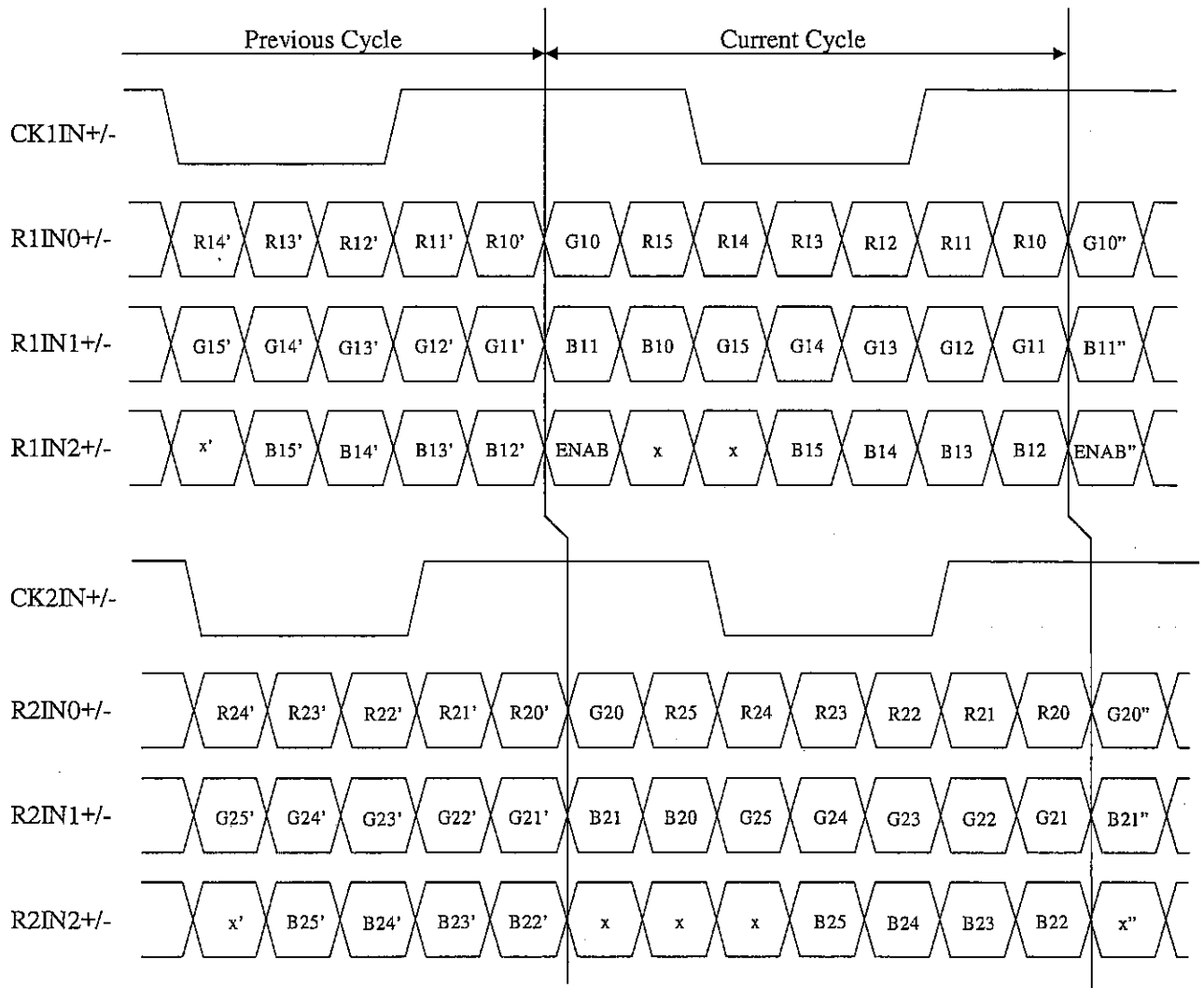

7. Timing characteristics of input signals

7-1. Timing characteristics

V_{CC}=+3.0V~+3.6V, T_a=0°C~+45°C

	Parameter	Symbol	Min.	Typ.	Max.	Unit	Remark
Clock	Frequency	1/T _c	40	54	56	MHz	[Note 1]
Data enable Signal	Horizontal period	TH	800	844	1044	clock	
			14.8	15.6	—	μs	
	Horizontal period (High)	THd	700	700	700	clock	
	Vertical period	TV	1054	1066	1080	Line	[Note 2]
			15.61	16.67	—	ms	
Vertical period (High)	TVd	1050	1050	1050	line		

[Note 1] Two pixels-data are sampled at the same time.

[Note 2] In case of using the long vertical period, the deterioration of display quality, flicker, etc, may occur.

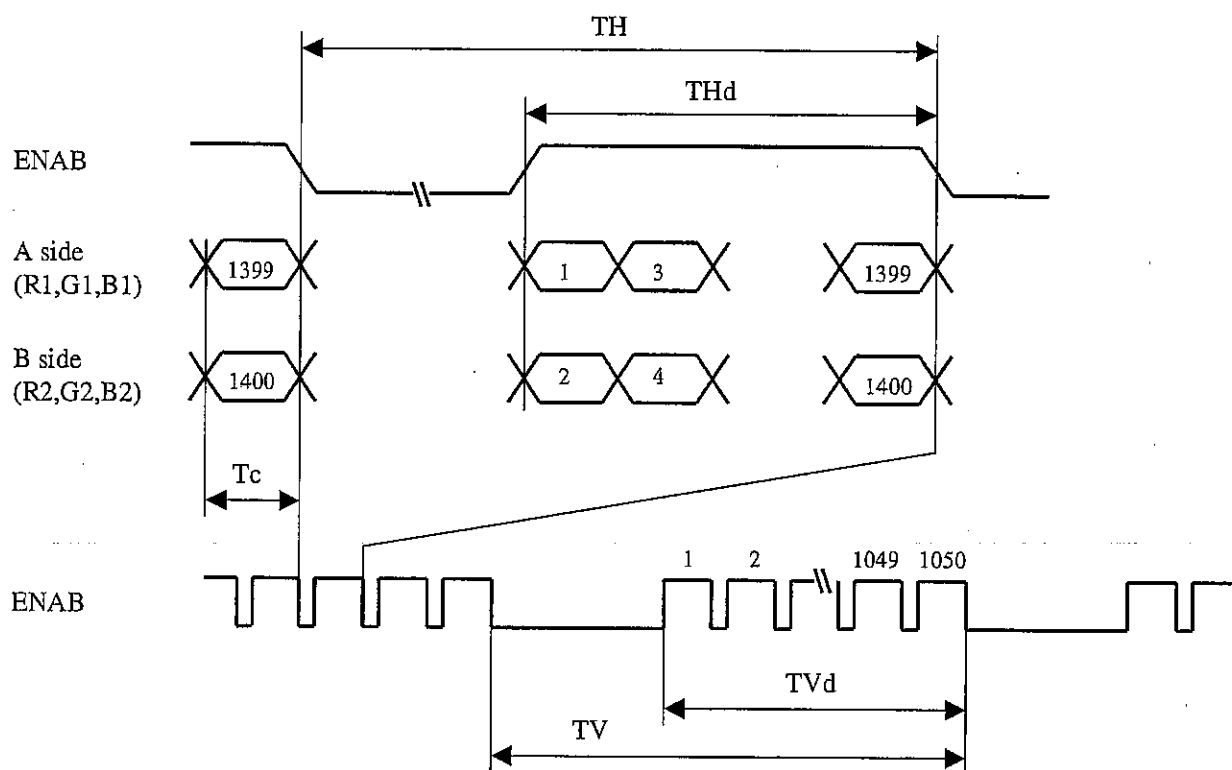

7-2. Input Data Signals and Display Position on the screen

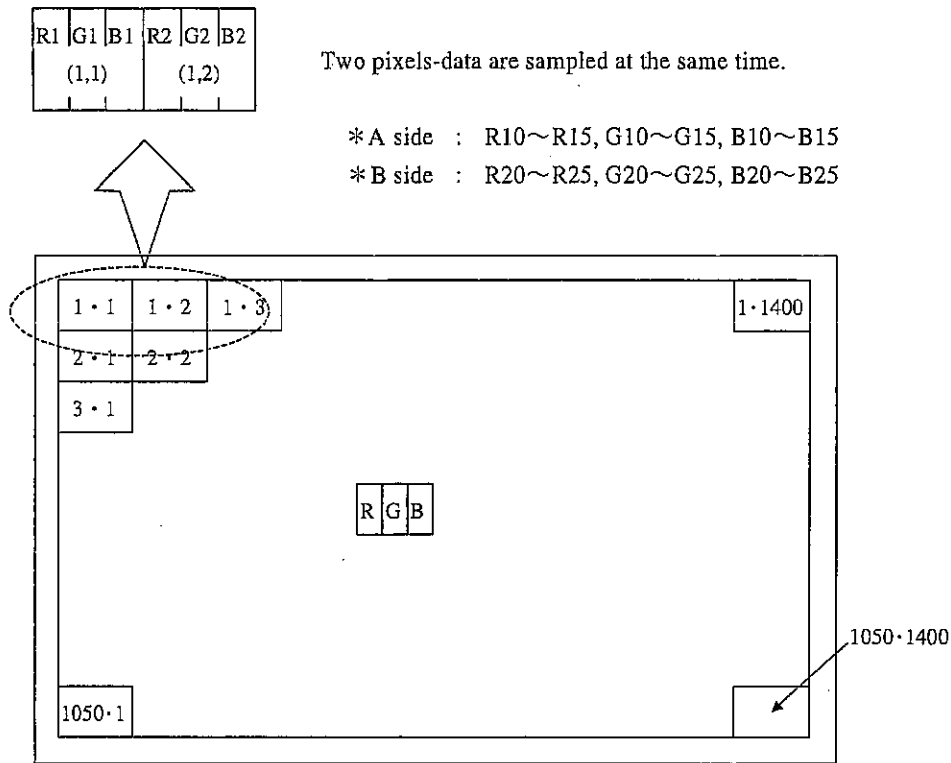

Display position of input data(V · H)

8. Input Signals, Basic Display Colors and Gray Scale of Each Color

Colors & Gray scale	Data signal																			
	Gray Scale	R0	R1	R2	R3	R4	R5	G0	G1	G2	G3	G4	G5	B0	B1	B2	B3	B4	B5	
Basic Color	Black	—	0	0	0	0	0	0	0	0	0	0	0	0	0	0	0	0	0	0
	Blue	—	0	0	0	0	0	0	0	0	0	0	0	0	1	1	1	1	1	1
	Green	—	0	0	0	0	0	0	1	1	1	1	1	1	0	0	0	0	0	0
	Cyan	—	0	0	0	0	0	0	1	1	1	1	1	1	1	1	1	1	1	1
	Red	—	1	1	1	1	1	1	0	0	0	0	0	0	0	0	0	0	0	0
	Magenta	—	1	1	1	1	1	1	0	0	0	0	0	0	1	1	1	1	1	1
	Yellow	—	1	1	1	1	1	1	1	1	1	1	1	1	0	0	0	0	0	0
	White	—	1	1	1	1	1	1	1	1	1	1	1	1	1	1	1	1	1	1
Gray Scale of Red	Black	GS0	0	0	0	0	0	0	0	0	0	0	0	0	0	0	0	0	0	0
	↑	GS1	1	0	0	0	0	0	0	0	0	0	0	0	0	0	0	0	0	0
	Darker	GS2	0	1	0	0	0	0	0	0	0	0	0	0	0	0	0	0	0	0
	↑	↓			↓					↓					↓					
	↓	↓			↓					↓					↓					
	Brighter	GS61	1	0	1	1	1	1	0	0	0	0	0	0	0	0	0	0	0	0
	↓	GS62	0	1	1	1	1	1	0	0	0	0	0	0	0	0	0	0	0	0
	Red	GS63	1	1	1	1	1	1	0	0	0	0	0	0	0	0	0	0	0	0
Gray Scale of Green	Black	GS0	0	0	0	0	0	0	0	0	0	0	0	0	0	0	0	0	0	0
	↑	GS1	0	0	0	0	0	0	1	0	0	0	0	0	0	0	0	0	0	0
	Darker	GS2	0	0	0	0	0	0	0	1	0	0	0	0	0	0	0	0	0	0
	↑	↓			↓					↓					↓					
	↓	↓			↓					↓					↓					
	Brighter	GS61	0	0	0	0	0	0	1	0	1	1	1	1	0	0	0	0	0	0
	↓	GS62	0	0	0	0	0	0	0	1	1	1	1	1	0	0	0	0	0	0
	Green	GS63	0	0	0	0	0	0	1	1	1	1	1	1	0	0	0	0	0	0
Gray Scale of Blue	Black	GS0	0	0	0	0	0	0	0	0	0	0	0	0	0	0	0	0	0	0
	↑	GS1	0	0	0	0	0	0	0	0	0	0	0	0	1	0	0	0	0	0
	Darker	GS2	0	0	0	0	0	0	0	0	0	0	0	0	0	1	0	0	0	0
	↑	↓			↓					↓					↓					
	↓	↓			↓					↓					↓					
	Brighter	GS61	0	0	0	0	0	0	0	0	0	0	0	0	1	0	1	1	1	1
	↓	GS62	0	0	0	0	0	0	0	0	0	0	0	0	0	1	1	1	1	1
	Blue	GS63	0	0	0	0	0	0	0	0	0	0	0	0	1	1	1	1	1	1

0 : Low level voltage, 1 : High level voltage

Each basic color can be displayed in 64 gray scales from 6 bit data signals. According to the combination of total 18 bit data signals, the 262,144-color display can be achieved on the screen.

9. Optical Characteristics

Ta=+25°C, Vcc=+3.3V

Parameter		Symbol	Condition	Min.	Typ.	Max.	Unit	Remark	
Viewing angle range	Horizontal	θ_{21}, θ_{22}	CR>5	70	80	—	Deg.	[Note 1,3,6]	
	Vertical	θ_{11}		50	60	—	Deg.		
		θ_{12}		60	70	—	Deg.		
	Horizontal	θ_{21}, θ_{22}	CR>10	60	70	—	Deg.	[Note 1,3,6]	
	Vertical	θ_{11}		40	50	—	Deg.		
		θ_{12}		50	60	—	Deg.		
Contrast ratio		CRn	$\theta = 0^\circ$	300	—	—		[Note 2,4,6]	
		CRo	Optimum viewing angle	300	450	—			
Response time		$\tau_r + \tau_d$	$\theta = 0^\circ$	—	30	60	ms	[Note 2,4,6]	
Chromaticity of white		x		0.292	0.322	0.352		[Note 2,6]	
		y		0.302	0.332	0.362			
Chromaticity of red		x		0.552	0.602	0.652			
		y		0.280	0.330	0.380			
Chromaticity of green		x		0.269	0.319	0.369			
		y		0.492	0.542	0.592			
Chromaticity of blue		x		0.098	0.148	0.198			
		y		0.077	0.127	0.177			
Luminance of white [Note 2,7]		Y_L			270	340	—		cd/m ²
White Uniformity		δ_w		—	1.20	1.40			[Note 2,8]

※ The measurement shall be executed 30 minutes after lighting at rating. Condition : ($I_L = 6.0 \text{mA rms}$) $\times 2$
The optical characteristics shall be measured in a dark room or equivalent.

[Note 1] Measuring Viewing Angle Range

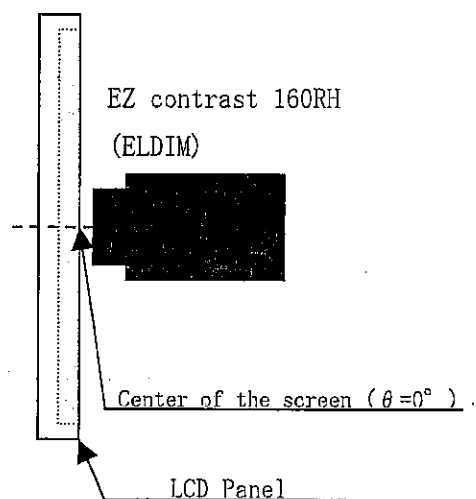

[Note 2] Other Measurements

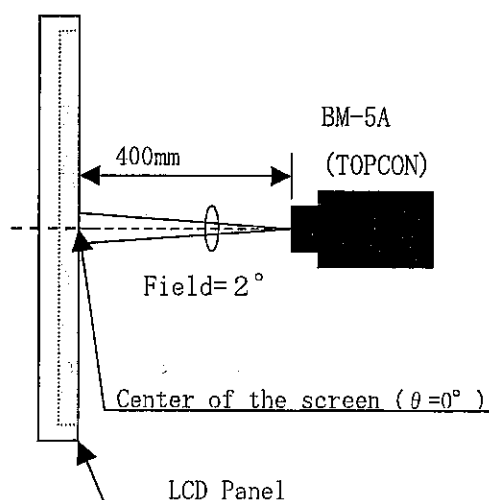

[Note 3] Definitions of viewing angle range:

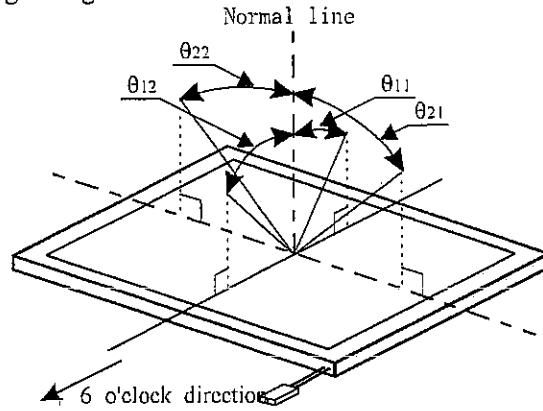

[Note 4] Definition of contrast ratio:

The contrast ratio is defined as the following.

$$\text{Contrast Ratio (CR)} = \frac{\text{Luminance (brightness) with all pixels white}}{\text{Luminance (brightness) with all pixels black}}$$

[Note 5] Definition of response time:

The response time is defined as the following figure and shall be measured by switching the input signal for "black" and "white".

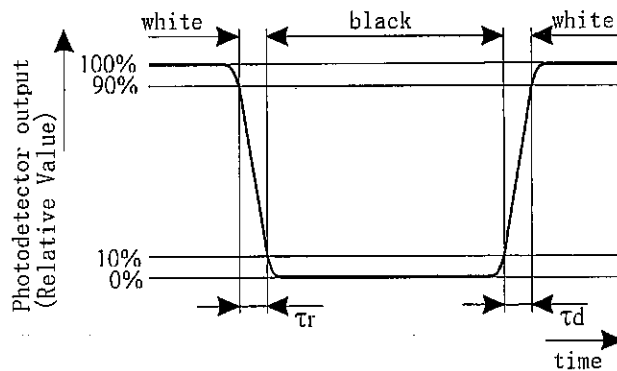

[Note 6] This shall be measured at center of the screen.

[Note 7] Average of five point.(A~E)

[Note 8] Definition of white uniformity:

White uniformity is defined as the following with five measurements (A~E).

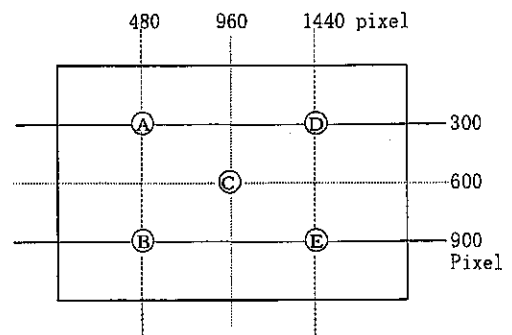

$$\delta_w = \frac{\text{Maximum Luminance of five points (brightness)}}{\text{Minimum Luminance of five points (brightness)}}$$

10. Display Quality

The display quality of the color TFT-LCD module shall be in compliance with the Incoming Inspection Standard.

11. Handling Precautions

- a) Be sure to turn off the power supply when inserting or disconnecting the cable.
- b) Be sure to design the cabinet so that the module can be installed without any extra stress such as warp or twist.
- c) Since the front polarizer is easily damaged, pay attention not to scratch it.
- d) Wipe off water drop immediately. Long contact with water may cause discoloration or spots.
- e) When the panel surface is soiled, wipe it with absorbent cotton or other soft cloth.
- f) Since the panel is made of glass, it may break or crack if dropped or bumped on hard surface. Handle with care.
- g) Since CMOS LSI is used in this module, take care of static electricity and injure the human earth when handling. Observe all other precautionary requirements in handling components.
- h) This module has its circuitry PCBs on the rear side and should be handled carefully in order not to be stressed.
- i) Protect sheet is attached to the module surface to prevent it from being scratched . Peel the sheet off slowly just before the use with strict attention to electrostatic charges. Ionized air shall be blown over during the action.
Blow off the 'dust' on the polarizer by using an ionized nitrogen gun, etc..
- j) Do not expose the LCD module to a direct sunlight, for a long period of time to protect the module from the ultra violet ray.
- k) Connect GND of mounting holes to stabilize against EMI and external noise.
- l) There are high voltage portions on the backlight and very dangerous. Careless touch may lead to electrical shock. When exchange lamps or service, turn off the power without fail.
- m) When handling LCD modules and assembling them into cabinets, please be noted that long-term storage in the environment of oxidization or deoxidization gas and the use of such materials as reagent, solvent, adhesive, resin, etc. which generate these gasses, may cause corrosion and discoloration of the LCD modules.
- n) Cold cathode fluorescent lamp in LCD panel contains a small amount of mercury, please follow local ordinances or regulations for disposal.
- o) Be sure not to apply tensile stress to the lamp lead cable.
- p) Adjusting volume have been set optimally before shipment, so do not change any adjusted value. If adjusted value is changed, the technical literature may not be satisfied.
- q) Disassembling the module can cause permanent damage and should be strictly avoided.
- r) Please be careful since image retention may occur when a fixed pattern is displayed for a long time.

12. Packing form

Piling number of cartons	Max.5
Package quantity in one carton	10 pcs
Carton size	459(W)×337(D)×332(H) mm
Total mass of one carton filled with full modules	12.3kg
Packing form	Fig.1

13. Reliability test items

No.	Test item	Conditions
1	High temperature storage test	Ta = 60°C 240h
2	Low temperature storage test	Ta = -25°C 240h
3	High temperature & high humidity operation test	Ta = 40°C ; 95 %RH 240h (No condensation)
4	High temperature operation test	Ta = 45°C 240h (The panel temp. must be less than 60°C)
5	Low temperature operation test	Ta = 0°C 240h
6	Vibration test (non- operating)	Frequency : 10~57Hz/Vibration width (one side):0.075mm : 58~500Hz/Gravity:9.8m/s ² Sweep time : 11 minutes Test period : 3 hours (1 hour for each direction of X,Y,Z)
7	Shock test (non- operating)	Max. gravity : 490 m/s ² Pulse width : 11 ms, sine wave Direction : ±X, ±Y, ±Z once for each direction.

[Result Evaluation Criteria]

Under the display quality test conditions with normal operation state, these shall be no change which may affect practical display function.

14. Label

1) Module label:

Notation: ①Model No. ②Serial No.

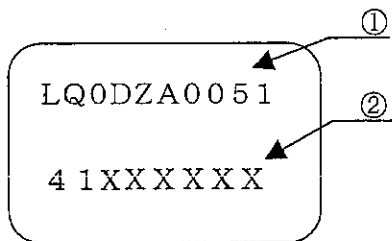

2) Packing bar code label

Notation: ①Model No. ②Quantity

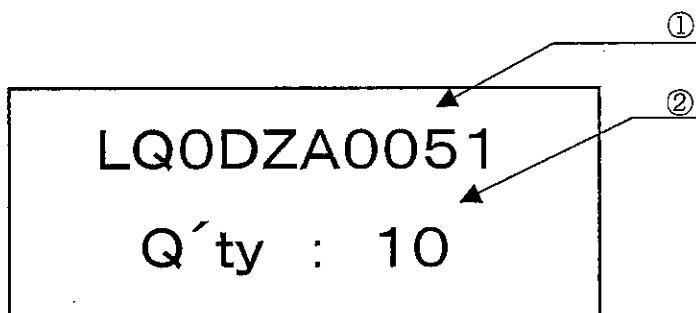

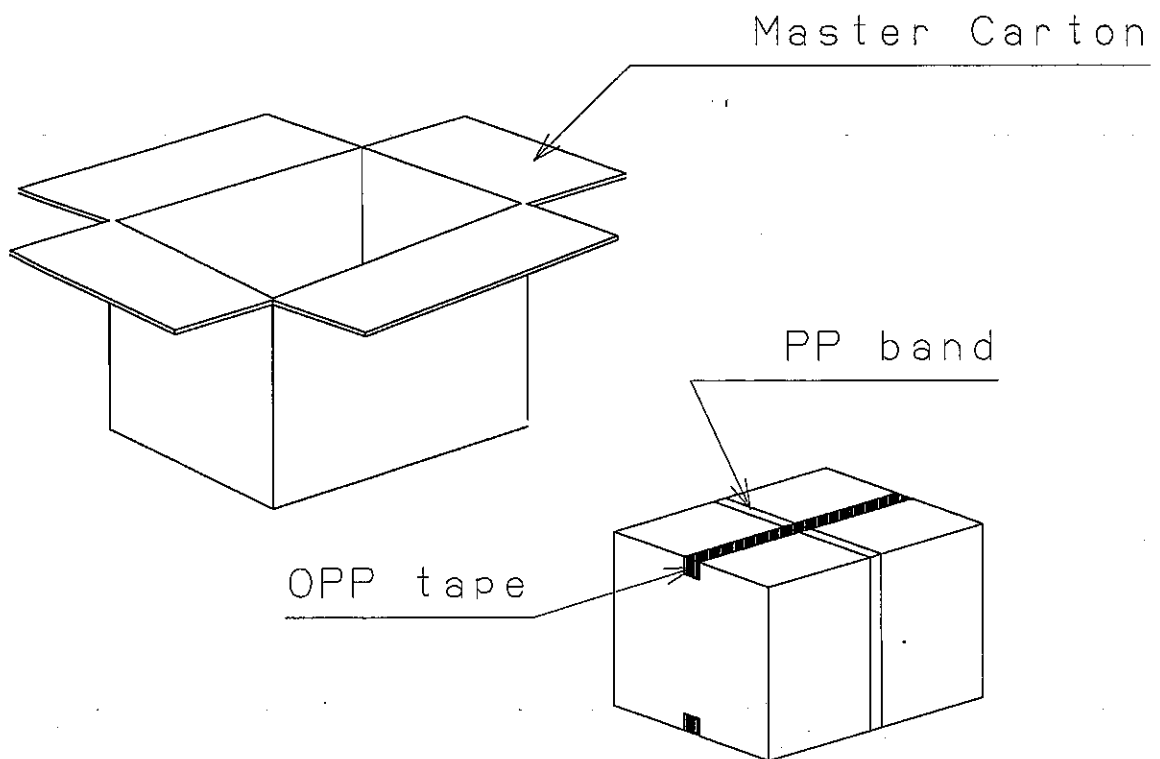
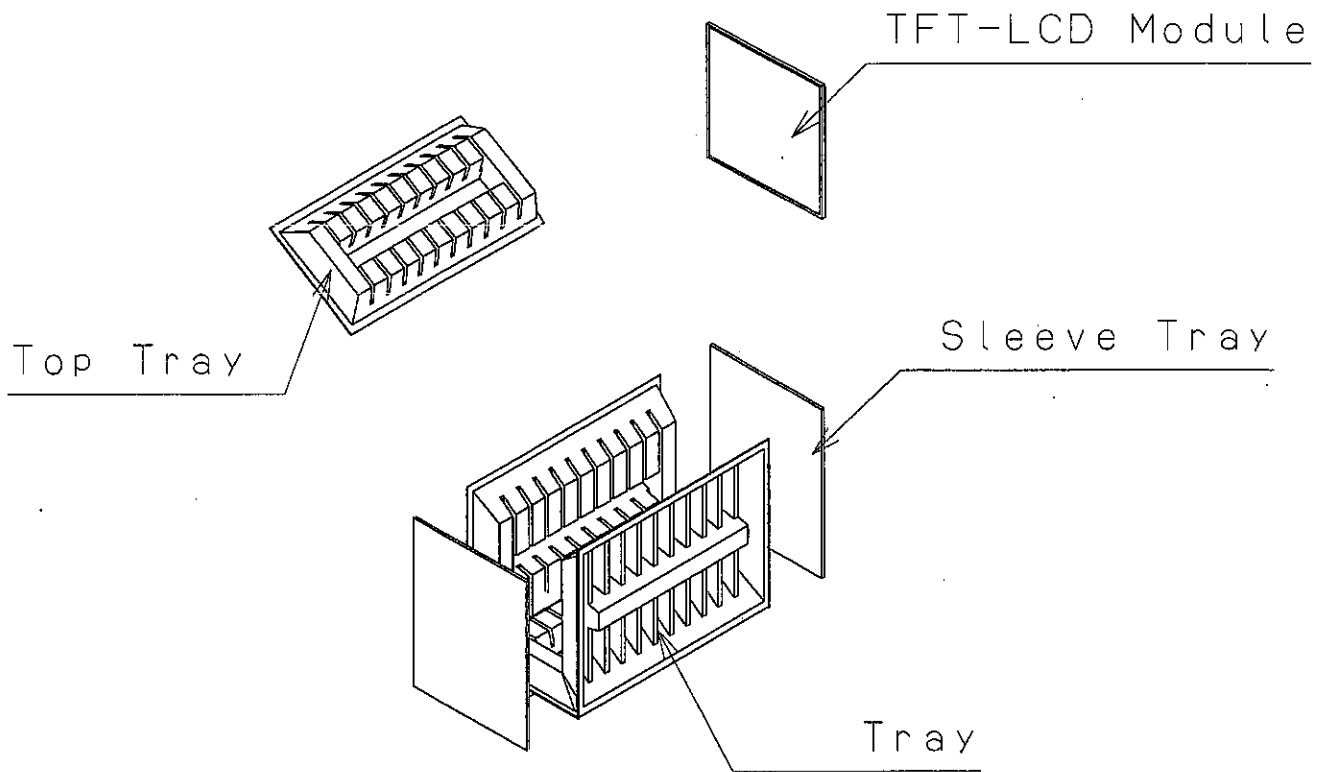

Fig.1 Packing Form (LQ0DZA0051)

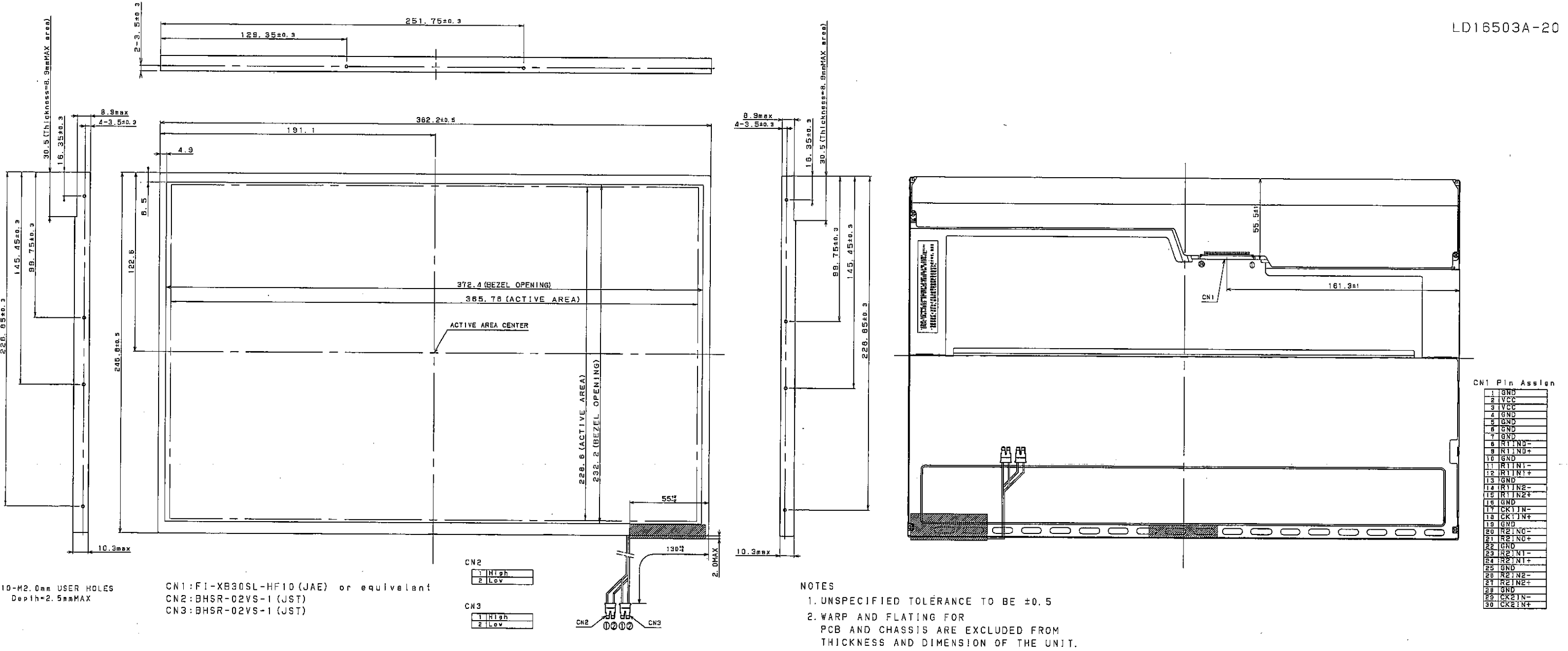

Fig. 2 LQ0DZA0051 OUTLINE DIMENSIONS