

LQ201U1LW11

TFT-LCD Module

(Model Number: LQ201U1LW11)

Specifications

Spec No.: LD-14117

Dated: May 29, 2002

PREPARED BY : DATE	 TFT LCD DEVELOPMENT GROUP SHARP CORPORATION SPECIFICATION	SPEC No. LD-14117
APPROVED BY : DATE		FILE No.
		ISSUE : Feb.25.2002
		PAGE : 23 pages
		APPLICABLE GROUP TFT Liquid Crystal Display Group

DEVICE SPECIFICATION
TFT-LCD Module
MODEL No.
LQ201U1LW11

CUSTOMER'S APPROVAL

DATE _____

BY _____

PRESENTED

BY _____

M.TAKEDA
Department General Manager
Development Engineering Department 2
AVC LIQUID CRYSTAL DISPLAY Division
AVC LIQUID CRYSTAL DISPLAY GROUP
SHARP CORPORATION

1. Application

This specification applies to the monochrome 20.1 UXGA TFT-LCD module LQ201U1LW11.

- ◎These specification sheets are the proprietary product of SHARP CORPORATION("SHARP) and include materials protected under copyright of SHARP. Do not reproduce or cause any third party to reproduce them in any form or by any means, electronic or mechanical, for any purpose, in whole or in part, without the express written permission of SHARP.
- ◎The device listed in these specification sheets was designed and manufactured for use in OA equipment.
- ◎In case of using the device for applications such as control and safety equipment for transportation(aircraft, trains, automobiles, etc.), rescue and security equipment and various safety related equipment which require higher reliability and safety, take into consideration that appropriate measures such as fail-safe functions and redundant system design should be taken.
- ◎In case of using the device for equipment that requires an extreme level of reliability, such as aerospace applications, telecommunication equipment(trunk lines), nuclear power control equipment and medical or other equipment for life support, contact and consult with a SHARP sales representative.
- ◎SHARP assumes no responsibility for any damage resulting from the use of the device which does not comply with the instructions and the precautions specified in these specification sheets.
- ◎Contact and consult with a SHARP sales representative for any questions about this device.

2. Overview

This module is a active matrix LCD module incorporating amorphous silicon TFT (Thin Film Transistor). It is composed of a monochrome TFT-LCD panel, driver ICs, control circuit, power supply circuit and a back light unit. Graphics and texts can be displayed on a $1600 \times XYZ \times 1200$ dots panel with about 256 gray scales (8bit) by supplying 48 bit data signals($8\text{bit} \times 2\text{pixel} \times XYZ$), two display enable signals, two dot clock signals, +12V DC supply voltages for TFT-LCD panel driving and supply voltage for back light.

It is a wide viewing-angle-module (Vertical viewing angle: 170° Horizontal viewing angle: 170° , $CR \geq 10$).

3. Mechanical Specifications

Parameter	Specifications	Unit
Display size	51 (Diagonal)	cm
	20.1 (Diagonal)	Inch
Active area	408.0 (H) × 306.0 (V)	mm
Pixel format	1600 (H) × 1200 (V)	Pixel
	(1 pixel = X + Y + Z dots)	
Pixel pitch	0.255(H) × 0.255 (V)	mm
Pixel configuration	X,Y,Z vertical stripe	
Display mode	Normally black	
Unit outline dimensions *1	436(W) × 335 (H) × 27.5 (D)	mm
Mass	3.8 (MAX)	kg
Surface treatment	Anti-glare And hard-coating 2H	

*1.Note: excluding back light cables.

The thickness of module (D) doesn't contain the projection.

Outline dimensions are shown in Fig.1.

4. Input Terminals

4-1. TFT-LCD panel driving

CN7A,CN7B (Interface signals and +12VDC power supply)

Using connectors : DF19G-20P-1H (Hirose Electric Co., Ltd.)

Corresponding connectors : DF19G-20S-1C (Hirose Electric Co., Ltd.)

DF19G-20S-1F (Hirose Electric Co., Ltd.)

Using LVDS receiver : Contained in a control IC

Corresponding LVDS transmitter : THC63LVDM83R(Thine) or compatible

CN 7 A

Pin No.	Symbol	Function	Remark
1	Vcc	+12V power supply	
2	Vcc	+12V power supply	
3	Vss	Gnd	
4	Vss	Gnd	
5	RAIN0-	Negative (-) LVDS differential data input (A port)	LVDS
6	RAIN0+	Positive (+) LVDS differential data input (A port)	LVDS
7	Vss	Gnd	
8	RAIN1-	Negative (-) LVDS differential data input (A port)	LVDS
9	RAIN1+	Positive (+) LVDS differential data input (A port)	LVDS
10	Vss	Gnd	
11	RAIN2-	Negative (-) LVDS differential data input (A port)	LVDS
12	RAIN2+	Positive (+) LVDS differential data input (A port)	LVDS
13	Vss	Gnd	
14	CKAIN-	Negative (-) LVDS differential clock input (A port)	LVDS
15	CKAIN+	Positive (+) LVDS differential clock input (A port)	LVDS
16	Vss	Gnd	
17	RAIN3-	Negative (-) LVDS differential data input (A port)	LVDS
18	RAIN3+	Positive (+) LVDS differential data input (A port)	LVDS
19	Vss	Gnd	
20	BLON	Back light ON signal (output) 【Note1】	Pull Up

【Note1】 BLON:It change from L to H at 7 frames after Vcc ON.

CN 7 B

Pin No.	Symbol	Function	Remark
1	Vcc	+12V power supply	
2	Vcc	+12V power supply	
3	Vss	Gnd	
4	Vss	Gnd	
5	RBIN0-	Negative (-) LVDS differential data input (B port)	LVDS
6	RBIN0+	Positive (+) LVDS differential data input (B port)	LVDS
7	Vss	Gnd	
8	RBIN1-	Negative (-) LVDS differential data input (B port)	LVDS
9	RBIN1+	Positive (+) LVDS differential data input (B port)	LVDS
10	Vss	Gnd	
11	RBIN2-	Negative (-) LVDS differential data input (B port)	LVDS
12	RBIN2+	Positive (+) LVDS differential data input (B port)	LVDS
13	Vss	Gnd	
14	CKBIN-	Negative (-) LVDS differential clock input (B port)	LVDS
15	CKBIN+	Positive (+) LVDS differential clock input (B port)	LVDS
16	Vss	Gnd	
17	RBIN3-	Negative (-) LVDS differential data input (B port)	LVDS
18	RBIN3+	Positive (+) LVDS differential data input (B port)	LVDS
19	Vss	Gnd	
20	SELLVDS	Select LVDS data order 【Note2】	Pull Up

【Note2】 This module has dual pixel port to receive dual pixel data at the same time . A port receives first pixel data and B port receives second pixel data in dual pixel data.

【Note2】 SELLVDS(Thine:THC63LVDM83R)

Transmitter		SELLVDS	
Pin No	Data	=L	=H
51	TA0	X0(LSB)	X2
52	TA1	X1	X3
54	TA2	X2	X4
55	TA3	X3	X5
56	TA4	X4	X6
3	TA5	X5	X7(MSB)
4	TA6	Y0(LSB)	Y2
6	TB0	Y1	Y3
7	TB1	Y2	Y4
11	TB2	Y3	Y5
12	TB3	Y4	Y6
14	TB4	Y5	Y7(MSB)
15	TB5	Z0(LSB)	Z2
19	TB6	Z1	Z3
20	TC0	Z2	Z4
22	TC1	Z3	Z5
23	TC2	Z4	Z6
24	TC3	Z5	Z7(MSB)
27	TC4	(NA)	(NA)
28	TC5	(RSV1)	(RSV1)
30	TC6	DE	DE
50	TD0	X6	X0(LSB)
2	TD1	X7(MSB)	X1
8	TD2	Y6	Y0(LSB)
10	TD3	Y7(MSB)	Y1
16	TD4	Z6	Z0(LSB)
18	TD5	Z7(MSB)	Z1
25	TD6	(NA)	(NA)

4-2 Interface block diagram

Using receiver : Contained in a control IC.

Corresponding Transmitter : THC63LVDM83R(THine electronics),DS90C383,DS90C383A(National semiconductor)

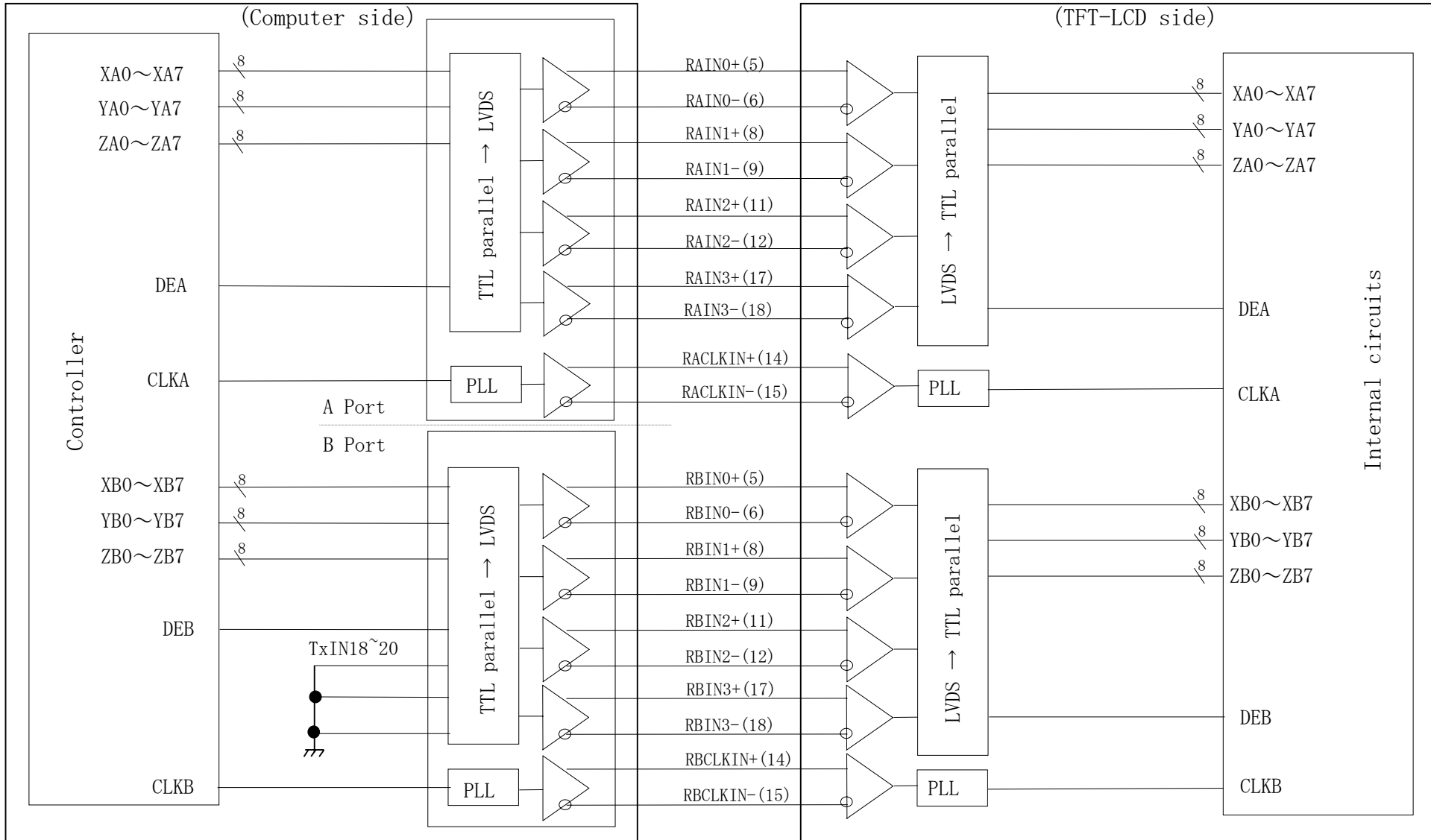

< SELLVDS= Low >

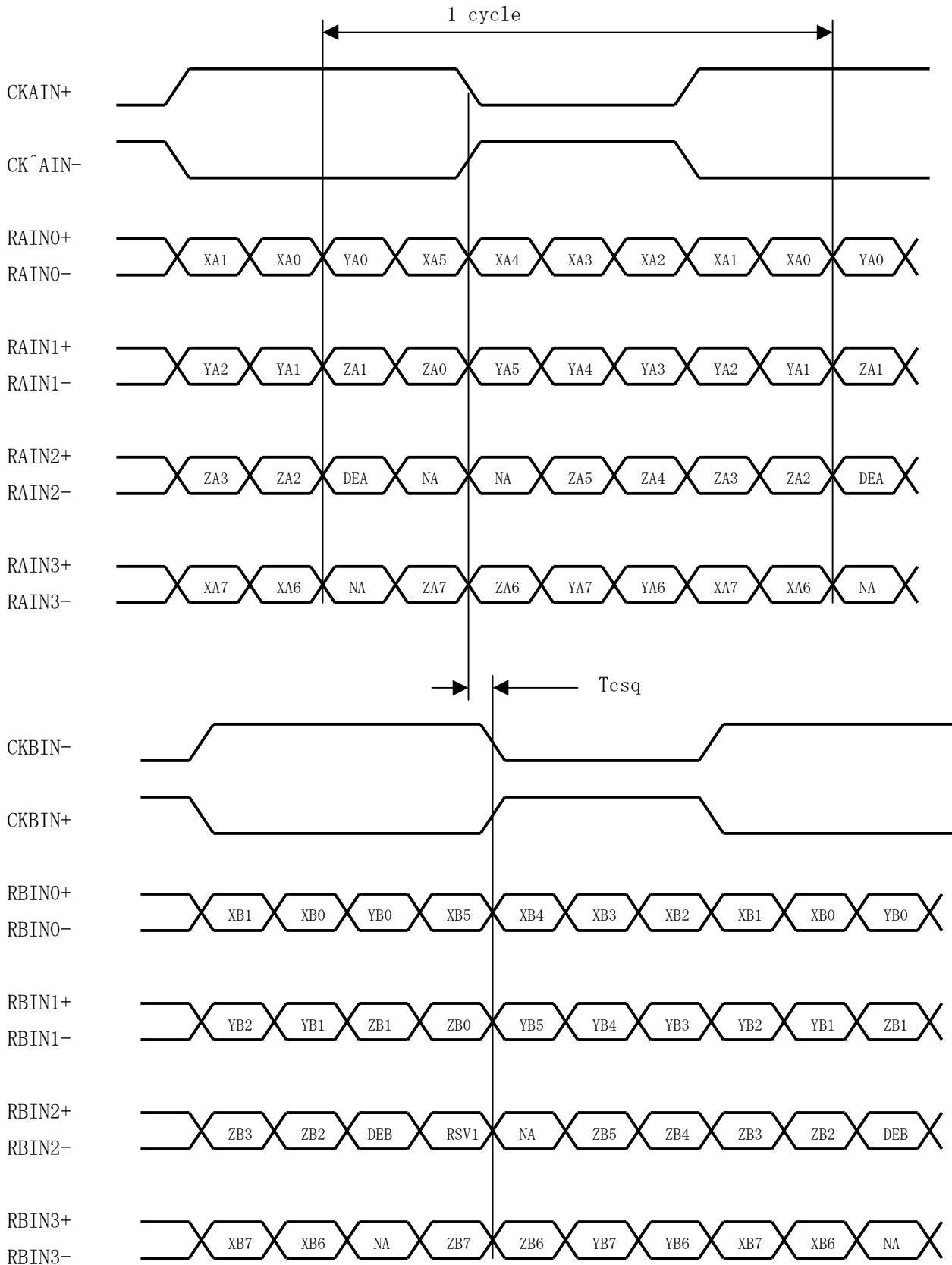

DE: Display Enable

RSV1: Reserve (Fixed GND)

NA: Not Available

< SELVDS= High >

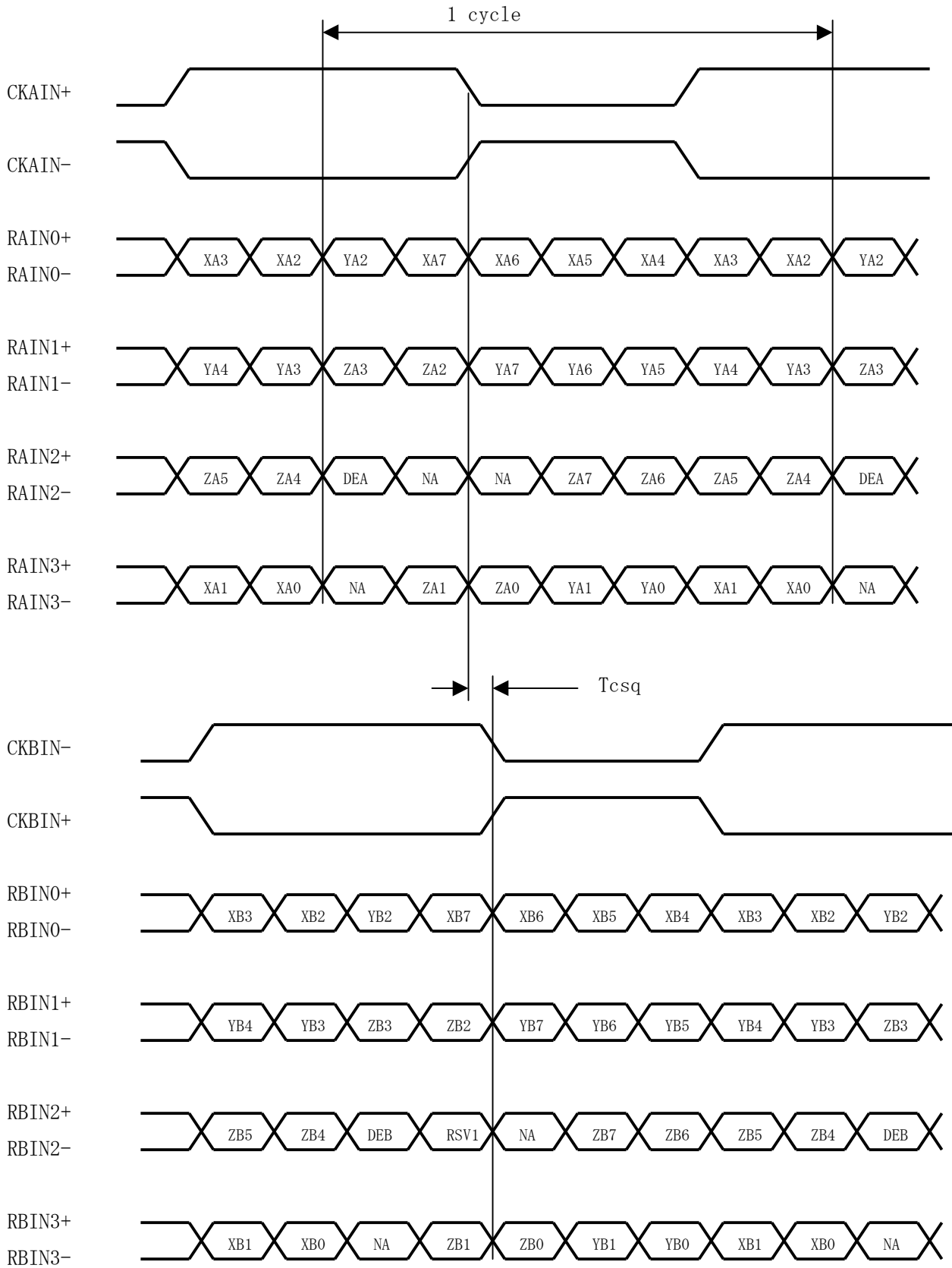

DE: Display Enable

RSV1: Reserve (Fixed GND)

NA: Not Available

4-2. Back light driving

CN 1, 2, 3 (Upside)

CN 4, 5, 6 (Downside)

The module-side connector : BHSR-02VS-01 (JST)

The user-side connector : SM02B-BHSS-1-TB (JST)

Pin no.	symbol	I/O	Function
1	V_{high}	I	Power supply (High voltage side)
2	V_{low}	I	Power supply (Low voltage side)

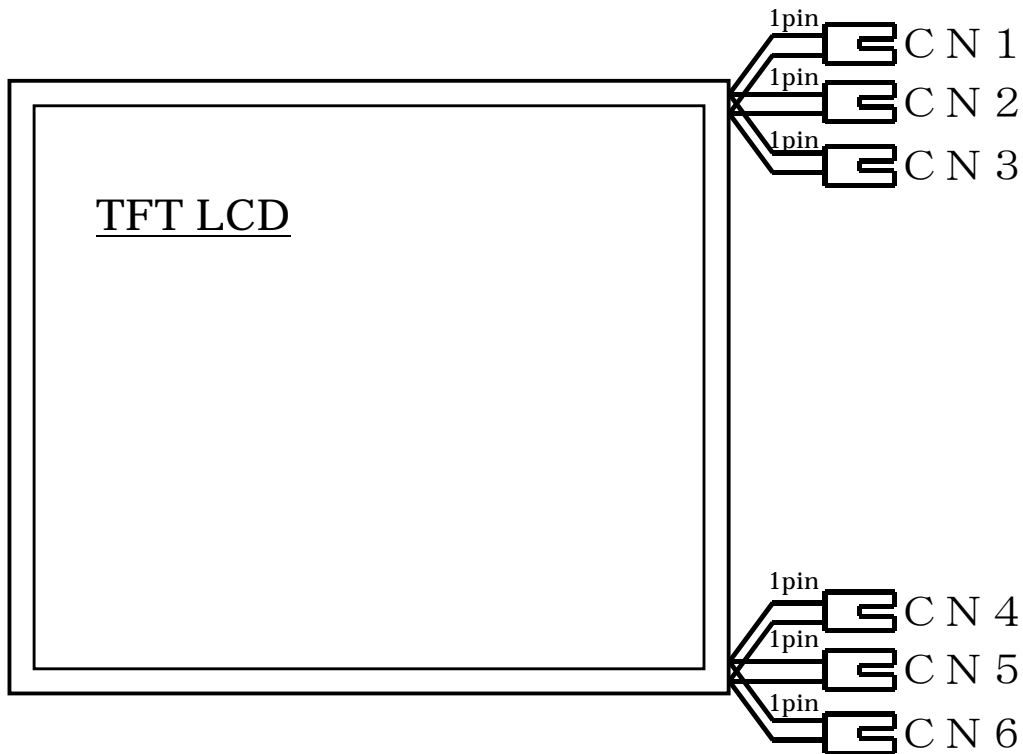

5. Absolute Maximum Ratings

Parameter	Symbol	Condition	Ratings	Unit	Remark
Input voltage	V_I	$T_a=25^\circ\text{C}$	$-0.3 \sim +3.6$	V	SELLVDS
+12.0V supply voltage	V_{cc}	$T_a=25^\circ\text{C}$	$0 \sim +14.0$	V	
Storage temperature	T_{stg}	—	$-25 \sim +60$	$^\circ\text{C}$	【Note1】
Operating temperature (Ambient)	T_{opa}	—	$0 \sim +50$	$^\circ\text{C}$	

【Note1】 Humidity : 95%RH Max. ($T_a \leq 40^\circ\text{C}$)

Maximum wet-bulb temperature at 39°C or less. ($T_a > 40^\circ\text{C}$)

No condensation.

6. Electrical Characteristics

6-1. TFT-LCD panel driving

Ta=25°C

Parameter		Symbol	Min.	Typ.	Max.	Unit	Remark
Vcc	Supply voltage	Vcc	+11.4	+12.0	+12.6	V	【Note1】
	Current dissipation	Icc	—	390	600	mA	【Note2】
Permissible input ripple voltage		V _{RF}	—	—	100	mVp-p	
Input voltage (Low)		V _{IL}	0	—	+0.6	V	SELLVDS
Input voltage (High)		V _{IH}	+2.7	—	+3.3	V	SELLVDS
Input current (Low)		I _{IL}	—	—	500	μA	V _I =GND
Input current (High)		I _{IH}	—	—	10	μA	V _I =Vcc
Output voltage (Low)		V _{OL}	—	—	0.4	V	BLON:I _{OL} =-1mA
Output voltage (High)		V _{OH}	2.4	—	—	V	BLON:I _{OH} =1mA

【Note1】

1) On-off sequences of Vcc and data

- 0 < t1 ≤ 60ms
- 0 < t2 ≤ 10ms
- 0 ≤ t3 ≤ 1s
- t4 ≥ 100ms

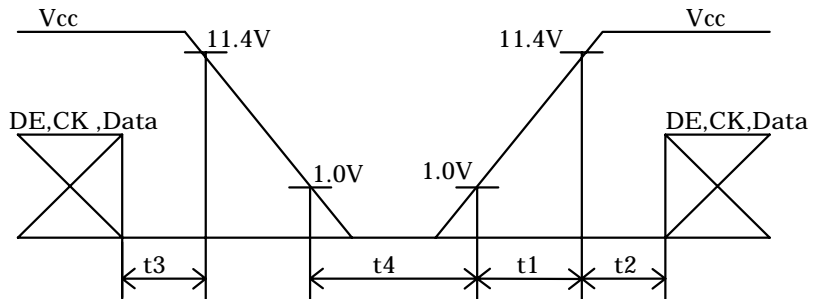

2) Dip conditions for supply voltage

V_{min} = 11.4V, V_{th} = 9.6V

- 1) V_{th} ≤ Vcc < V_{min}
t_d ≤ 20ms
- 2) Vcc < V_{th}

The LCD module shuts down.

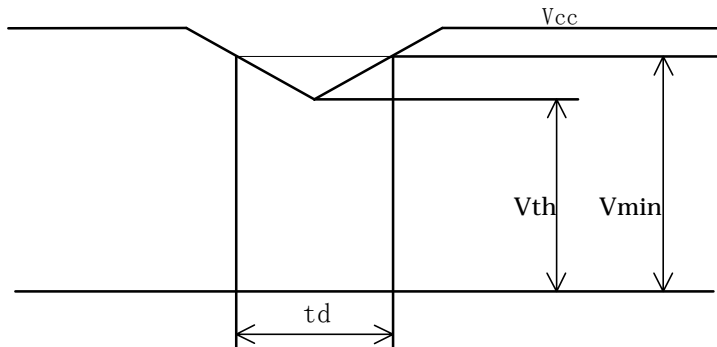

【Note2】 Typical current situation : 16-gray-bar pattern

Vcc=+12.0V

The explanation of each gray scale, GS , is described below section 8.

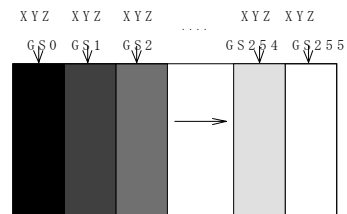

6-2. Back light driving

The back light system is an edge-lighting type with six CCFTs (Cold Cathode Fluorescent Tube).

The characteristics of the lamp are shown in the following table.

The value mentioned below is at the case of one CCFT.

CCFT Model Name : KTBE26MSTF - A424NE209 - Z - 3 (STANLEY. ELECTRIC. CO., LTD)

Parameter	Symbol	Min.	Typ.	Max.	Unit	Remark
Lamp current range	I_L	3.0	6.0	6.5	mArms	【Note1】
Lamp voltage	V_L	—	790	—	Vrms	Ta=25°C
Lamp power consumption	P_L	—	4.7	—	W	【Note2】
Lamp frequency	F_L	30	60	70	KHz	【Note3】
Kick-off voltage	V_s	—	—	1,500	Vrms	Ta=25°C 【Note4】
		—	—	2,000	Vrms	Ta=0°C 【Note4】
Lamp life time	T_L	50,000	—	—	hour	【Note5】

【Note1】 A lamp can be light in the range of lamp current shown above.

Maximum rating for current is measured by high frequency current measurement equipment connected to V_{Low} at circuit showed below.

(Note : To keep enough kick-off voltage and necessary steady voltage for CCFT.)

Lamp frequency : 30~70kHz

Ambient temperature : 0~50°C

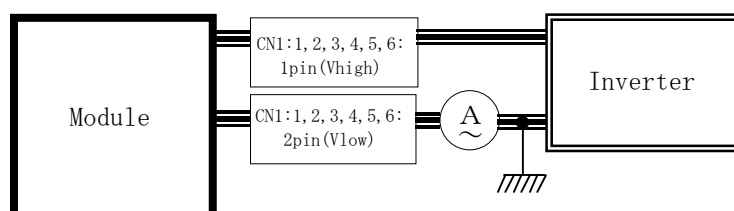

【Note2】 Referential data per one CCFT by calculation ($I_L \times V_L$).

The data doesn't include loss at inverter .

【Note3】 Lamp frequency of inverter may produce interference with horizontal synchronous frequency, and this may cause horizontal beat on the display. Therefore, adjust lamp frequency, and keep inverter as far as from module or use electronic shielding between inverter and module to avoid interference.

【Note4】 Kick-off voltage value is described as the index in the state of lamp only.

The kick-off voltage is estimated to be risen up as approx. +200V in the state of module only, and the further rise up can be seen according to the assembling status of user cabinet. Please set the kick-off voltage of inverter to avoid the lighting failures in the state of operation. Please design the inverter so that its open output voltage can be connected for more than 1 second to startup. Otherwise, the lamp may not be turned on. But, please set as 100ms when the ambient luminance around the lamp is more than 1lux.

【Note5】 Lamp life time is defined as the time when either ① or ② occurs in the continuous operation under the condition of Ta=25°C and $I_L=6.0$ mArms .

① Brightness becomes 50% of the original value under standard condition.

② Kick-off voltage at Ta=0°C exceeds maximum value,2000Vrms .

《Note》

The performance of the backlight, for example lifetime or brightness, is much influenced by the characteristics of the DC-AC inverter for the lamp. When you design or order the inverter, please make sure that a poor lighting caused by the mismatch of the backlight and the inverter (miss-lighting, flicker, etc.) never occurs. When you confirm it, the module should be operated in the same condition as it is installed in your instrument.

Use the lamp inverter power source incorporating such safeguard as overvoltage / overcurrent protective circuit or lamp voltage waveform detection circuit, which should have individual control of each lamp.

In case one circuit without such individual control is connected to more than two lamps, excessive current may flow into one lamp when the other one is not in operation.

Synchronize frequency and phase of two CCFT in the same connector.

Otherwise it may exceed rated voltage of connector.

7. Timing characteristics of input signals

7-1-1. Timing characteristics

Parameter		Symbol	Min.	Typ.	Max.	Unit	Remark
Clock	Frequency	1/Tc	60.0	81.0	85.0	MHz	
	Skew	Tcsq	-4	0	4	ns	【Note1】
Data enable signal	Horizontal period	TH	830	1080	1600	clock	
			10.0	13.3	—	μs	
	Horizontal period (High)	THd	800	800	800	clock	
	Vertical period	TV	1205	1250	2000	line	【Note2】
			12.1	16.7	—	ms	
Vertical period (High)	TVd	1200	1200	1200	line		

【Note1】 Lvds (A port)– Lvds (B port) phase difference

【Note2】 In case of using the long vertical period, the deterioration of display quality, flicker etc. may occur.

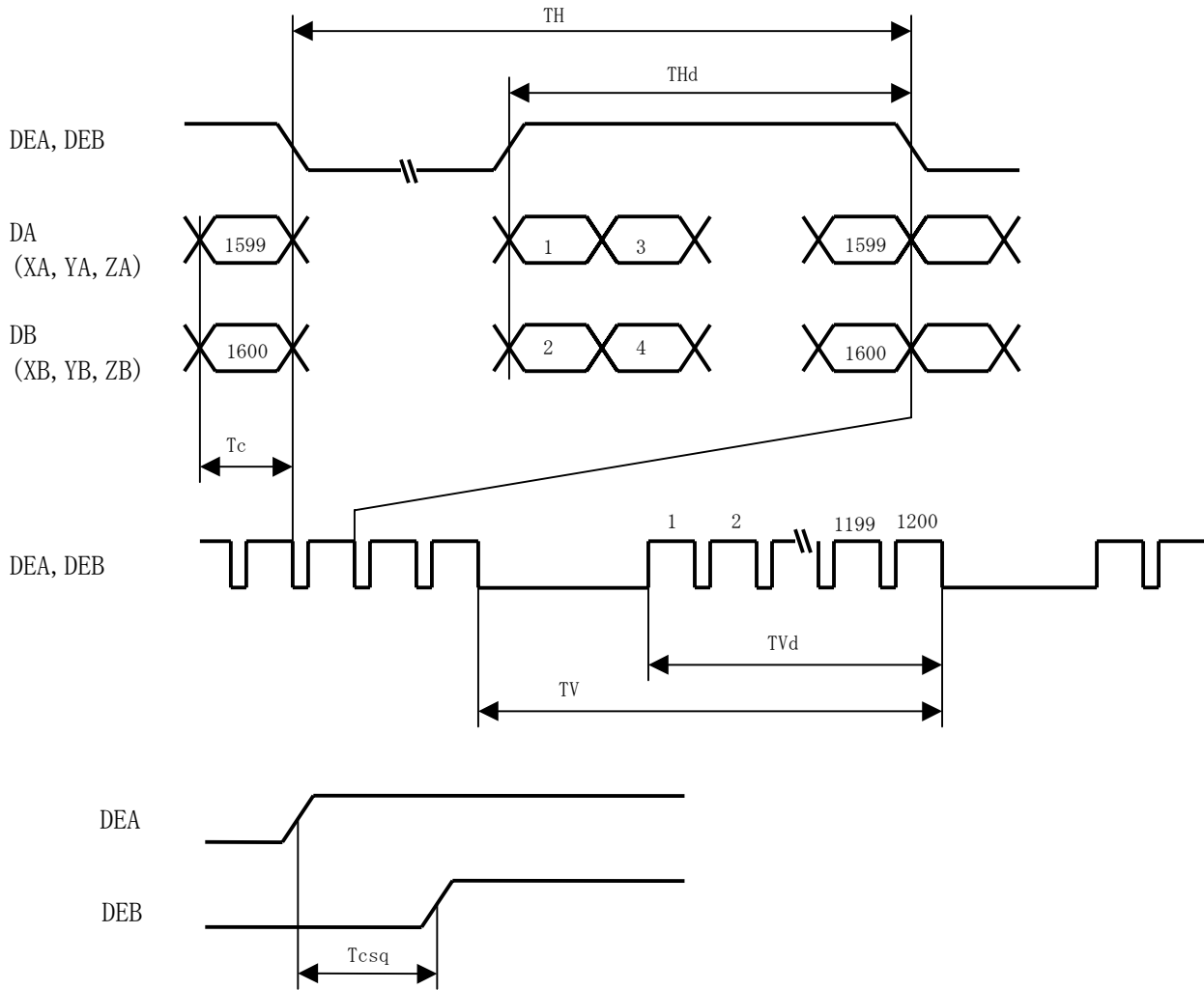

7-2 Input Data Signals and Display Position on the screen

Graphics and texts can be displayed on a 1600 × 3 × 1200 dots panel.

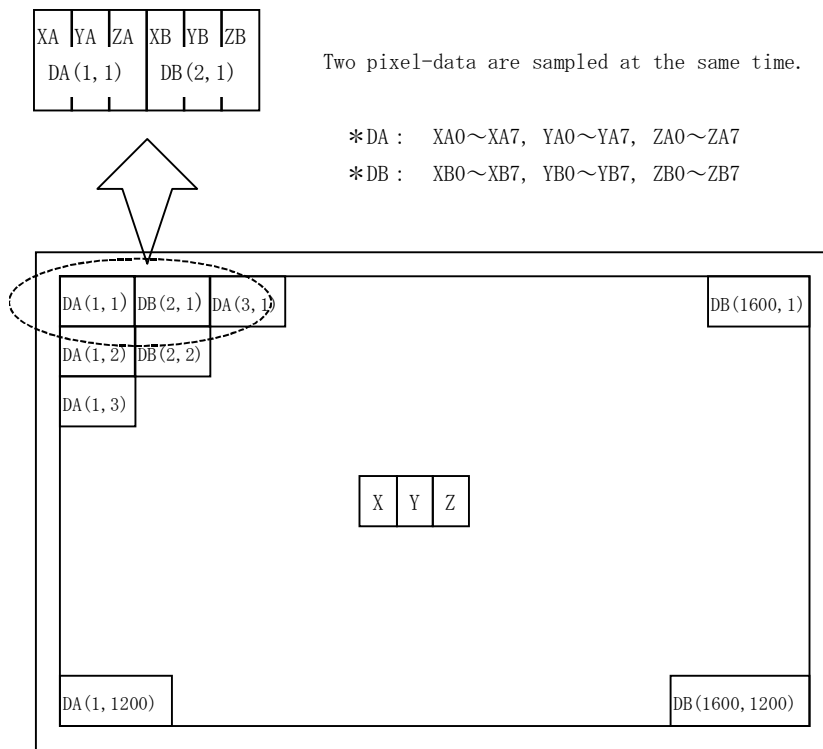

Display position of input data (H, V)

8. Input Signals, Basic Display Color and Gray Scale

	Color & Gray scale	Data signal																											
		Gray Scale	XA0	XA1	XA2	XA3	XA4	XA5	XA6	XA7	YA0	YA1	YA2	YA3	YA4	YA5	YA6	YA7	ZA0	ZA1	ZA2	ZA3	ZA4	ZA5	ZA6	ZA7			
			XB0	XB1	XB2	XB3	XB4	XB5	XB6	XB7	YB0	YB1	YB2	YB3	YB4	YB5	YB6	YB7	ZB0	ZB1	ZB2	ZB3	ZB4	ZB5	ZB6	ZB7			
Gray Scale	Black	0	0	0	0	0	0	0	0	0	0	0	0	0	0	0	0	0	0	0	0	0	0	0	0	0	0		
	↑	1	1	0	0	0	0	0	0	0	1	0	0	0	0	0	0	0	1	0	0	0	0	0	0	0	0		
	Darker	2	0	1	0	0	0	0	0	0	0	1	0	0	0	0	0	0	0	1	0	0	0	0	0	0	0		
	↑	↓	↓							↓							↓												
	↓	↓	↓							↓							↓												
	Brighter	253	1	0	1	1	1	1	1	1	1	0	1	1	1	1	1	1	1	0	1	1	1	1	1	1	1		
	↓	254	0	1	1	1	1	1	1	1	0	1	1	1	1	1	1	1	1	0	1	1	1	1	1	1	1		
	White	255	1	1	1	1	1	1	1	1	1	1	1	1	1	1	1	1	1	1	1	1	1	1	1	1	1		

0 : Low level voltage, 1 : High level voltage.

Basic color can be displayed in 256 gray scales from 8 bit data signals.

9. Optical Characteristics

Ta=25°C, Vcc =+12V

Parameter		Symbol	Condition	Min.	Typ.	Max.	Unit	Remark
Viewing Angle range	Vertical	$\theta 11$	$(CR \geq 10)$	70	85	—	Deg.	【Note1,4】
		$\theta 12$		70	85	—	Deg.	
	Horizontal	$\theta 21, \theta 22$		70	85	—	Deg.	
Contrast ratio		C R	$\theta = 0^\circ$	—	1000	—		【Note2,4】
Response Time	Rise	τd		—	5	25	m s	【Note3,4】
	Decay	τr		—	20	50	m s	
Chromaticity of white		W_x		0.264	0.294	0.324	—	【Note4】
		W_y		0.279	0.309	0.339	—	
Luminance of white		Y_L		560	700	—	cd/m ²	IL=6.0mA rms FL=60kHz 【Note4】
White Uniformity		δw		—	—	1.25	—	【Note5】

※The measurement shall be executed 30 minutes after lighting at rating.

The optical characteristics shall be measured in a dark room or equivalent state with the method shown in Fig.2 below.

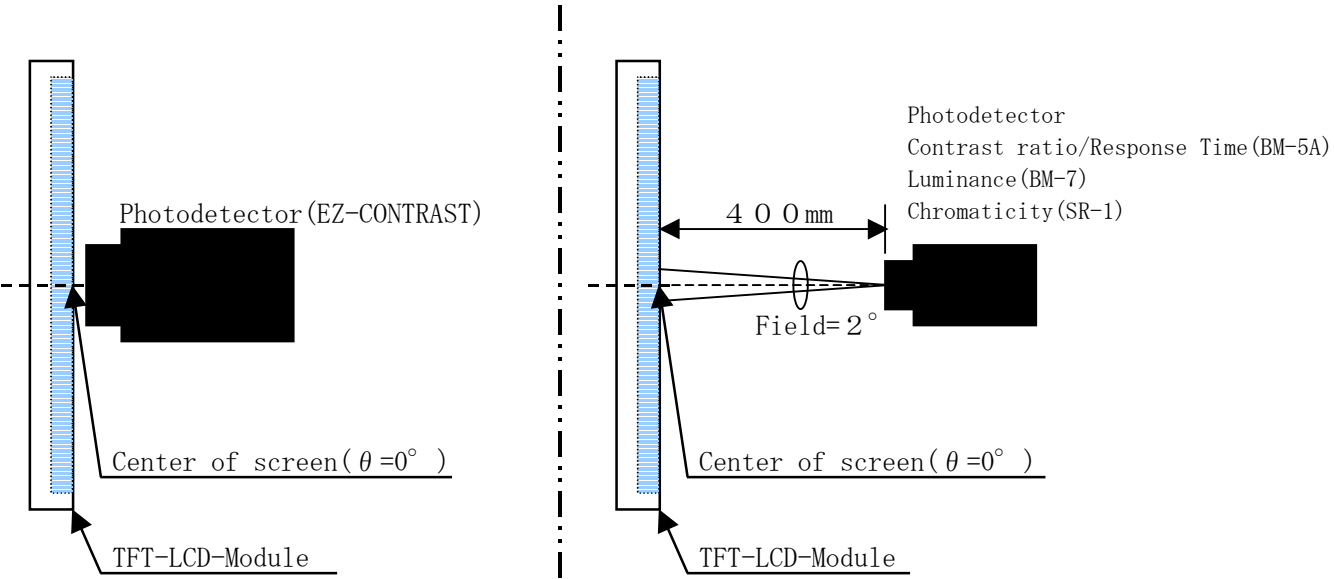
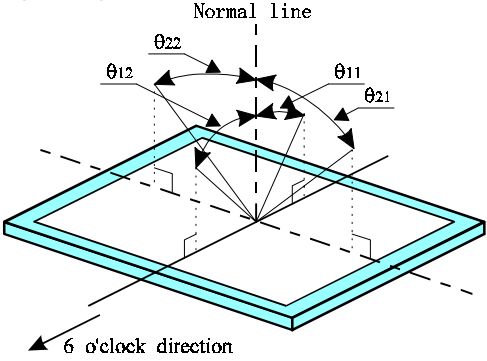

Fig. 2-1 Viewing angle measurement method

Fig. 2-2 Luminance/Contrast ratio/Response time/Chromaticity measurement method

Fig. 2 Optical characteristics measurement method

【Note1】 Definitions of viewing angle range:



【Note2】 Definition of contrast ratio:

The contrast ratio is defined as the following.

$$\text{Contrast Ratio (CR)} = \frac{\text{Luminance (brightness) with all pixels white}}{\text{Luminance (brightness) with all pixels black}}$$

【Note3】 Definition of response time:

The response time is defined as the following figure and shall be measured by switching the input signal for "black" and "white".

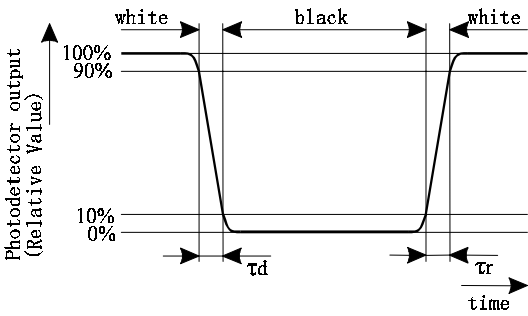

【Note4】 This shall be measured at center of the screen.

【Note5】 Definition of white uniformity:

White uniformity is defined as the following with five measurements (A~E).

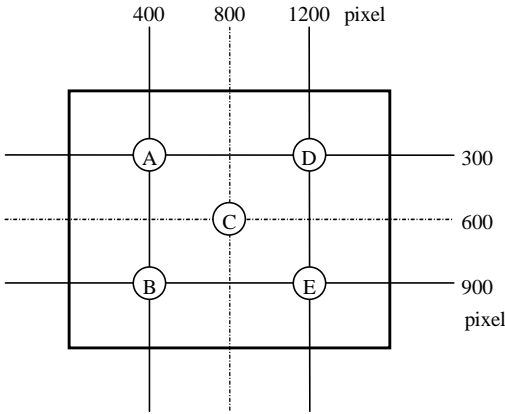

$$\delta_w = \frac{\text{Maximum Luminance of five points (brightness)}}{\text{Minimum Luminance of five points (brightness)}}$$

10. Handling Precautions

- a) Be sure to turn off the power supply when inserting or disconnecting the cable.
- b) Be sure to design the cabinet so that the module can be installed without any extra stress such as warp or twist.
- c) Since the front polarize is easily damaged, pay attention not to scratch it.
- d) Since long contact with water may cause discoloration or spots, wipe off water drop immediately.
- e) When the panel surface is soiled, wipe it with absorbent cotton or other soft cloth.
- f) Since the panel is made of glass, it may break or crack if dropped or bumped on hard surface. Handle with care.
- g) Since CMOS LSI is used in this module, take care of static electricity and take the human earth into consideration when handling.
- h) Make sure the mounting holes of the module are grounded sufficiently. Take electro-magnetic interference (EMI) into consideration.
- i) The module has some printed circuit boards (PCBs) on the back side. Take care to keep them from any stress or pressure when handling or installing the module; otherwise some of electronic parts on the PCBs may be damaged.
- j) Observe all other precautionary requirements in handling components.
- k) When some pressure is added onto the module from rear side constantly, it causes display non-uniformity issue, functional defect, etc. So, please avoid such design.
- l) If the stress is applied onto the panel under operating conditions, display defects such as black dots may occur. So, do not press the display with fingers.

To recover this defect, turn off the power supply and restart after several seconds.

11. Packing form

- a) Piling number of cartons : maximum 8 cartons
- b) Packing quantity in one carton : 2 module
- c) Carton size : 592mm(W) × 486mm(H) × 215(D)
- d) Total mass of one carton filled with full modules : 10.5kg
- e) Packing form is shown in Fig.3

12. Reliability test items

No.	Test item	Conditions
1	High temperature storage test	Ta=60°C 240h
2	Low temperature storage test	Ta= -25°C 240h
3	High temperature & high humidity operation test	Ta= 40°C ; 95%RH 240h (No condensation)
4	High temperature operation test	Ta=50°C 240h (The panel temp. must be less than 60°C)
5	Low temperature operation test	Ta=0°C 240H
6	Vibration test (non- operating)	Frequency : 10~57Hz/Vibration width (one side) : 0.075mm : 58~500Hz/Gravity : 9.8m/s ² Sweep time : 11 minutes Test period : 3 hours (1 hour for each direction of X,Y,Z)
7	Shock test (non- operating)	Max. gravity : 490m/s ² Pulse width : 11ms, sine wave Direction : ±X, ±Y, ±Z, once for each direction.

【Result Evaluation Criteria】

Under the display quality test conditions with normal operation state, these shall be no change which may affect practical display function.

13. Others

1) Lot No. and indication Bar Code Label:

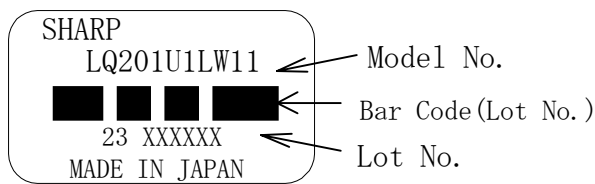

How to express Lot No.

A production year
(the last figures of
the Christian Era)

Serial No.

A production month (1~9, X, Y, Z)

2) Packing Label

- ① Model No. (LQ201U1LW11) ② Lot No. (Date) ③ Quantity

社内品番 : (4 S) LQ201U1LW11	
Bar Code (①)	
Lot NO.	: (1 T) 2002. 03. 01
Bar Code (②)	
Quantity : (Q)	2 pcs
Bar Code (③)	
ユーザ品番	:
シャープ物流用ラベルです。	

3) Adjusting volume have been set optimally before shipment, so do not change any adjusted value.

If adjusted value is changed, the specification may not be satisfied.

4) Disassembling the module can cause permanent damage and should be strictly avoided.

5) Please be careful since image retention may occur when a fixed pattern is displayed for a long time.

6) The chemical compound that causes the destruction of ozone layer is not being used.

7) Warning of mercury and material information of LPG(Light Pipe Guide) are labeled on the back of the module.

MATERIAL INFORMATION
>PLASTIC LIGHT GUIDE:PMMA<

COLD CATHODE FLUORESCENT LAMP IN LCD PANEL
CONTAINS A SMALL AMOUNT OF MERCURY, PLEASE FOLLOW
LOCAL ORDINANCES OR REGULATION FOR DISPOSAL
当該液晶ディスプレイパネルは蛍光管が組み込まれていますので、地方自治体の条例、または、規則に従って廃棄ください。

8) When any question or issue occurs, it shall be solved by mutual discussion.

14. Carton storage condition

Temperature 0°C to 40°C

Humidity 95%RH or less

Reference condition : 20°C to 35°C , 85%RH or less (summer)

: 5°C to 15°C , 85%RH or less (winter)

• the total storage time (40°C,95%RH) : 240H or less

Sunlight Be sure to shelter a product from the direct sunlight.

Atmosphere Harmful gas, such as acid and alkali which bites electronic components and/or wires, must not be detected.

Notes Be sure to put cartons on palette or base, don't put it on floor, and store them with removing from wall.

Please take care of ventilation in storehouse and around cartons, and control changing temperature is within limits of natural environment.

Storage period 1 year

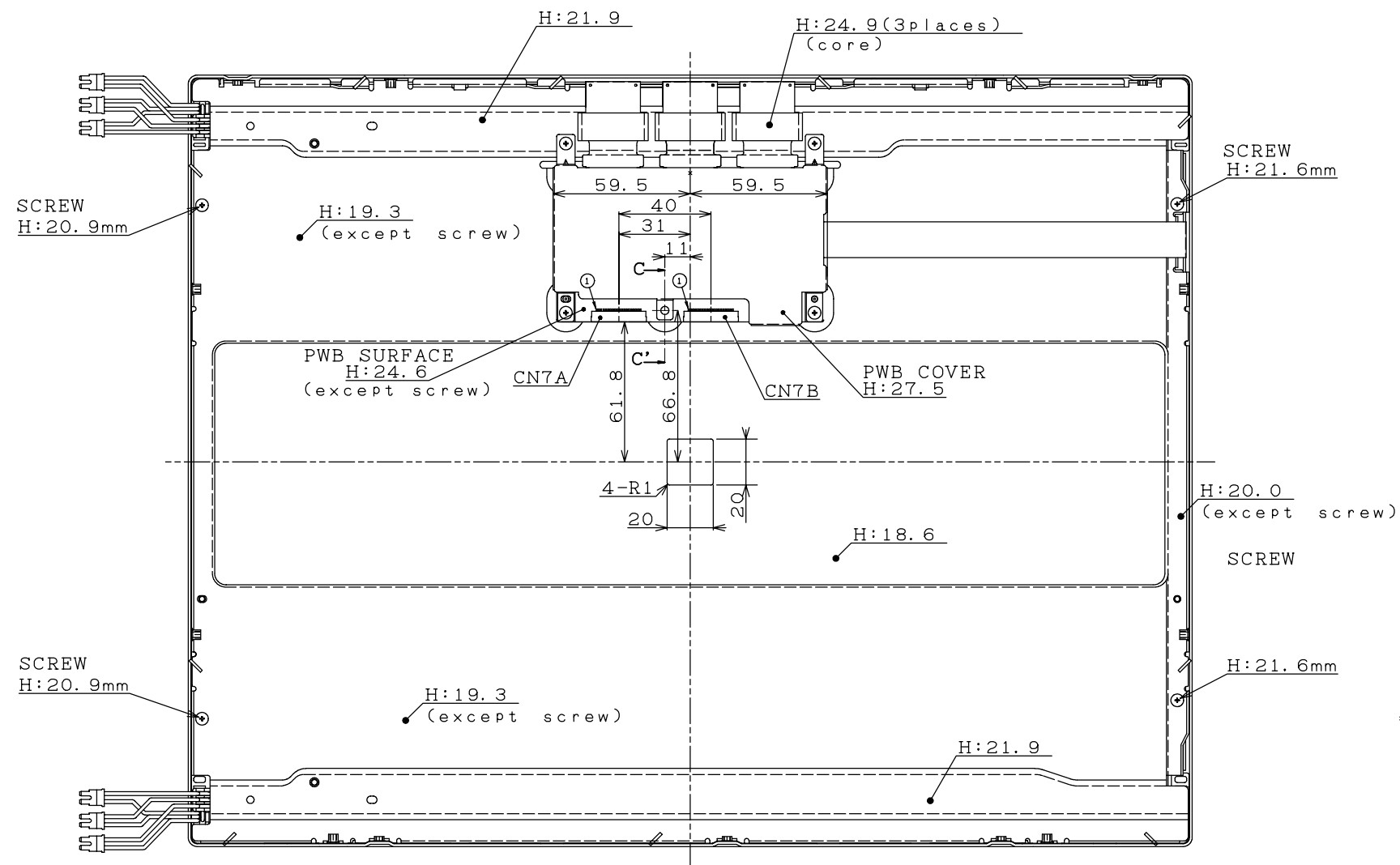

I/F CONNECTOR

CN7A:DF19G-20P-1H(HIROSE)
 CN7B:DF19G-20P-1H(HIROSE)

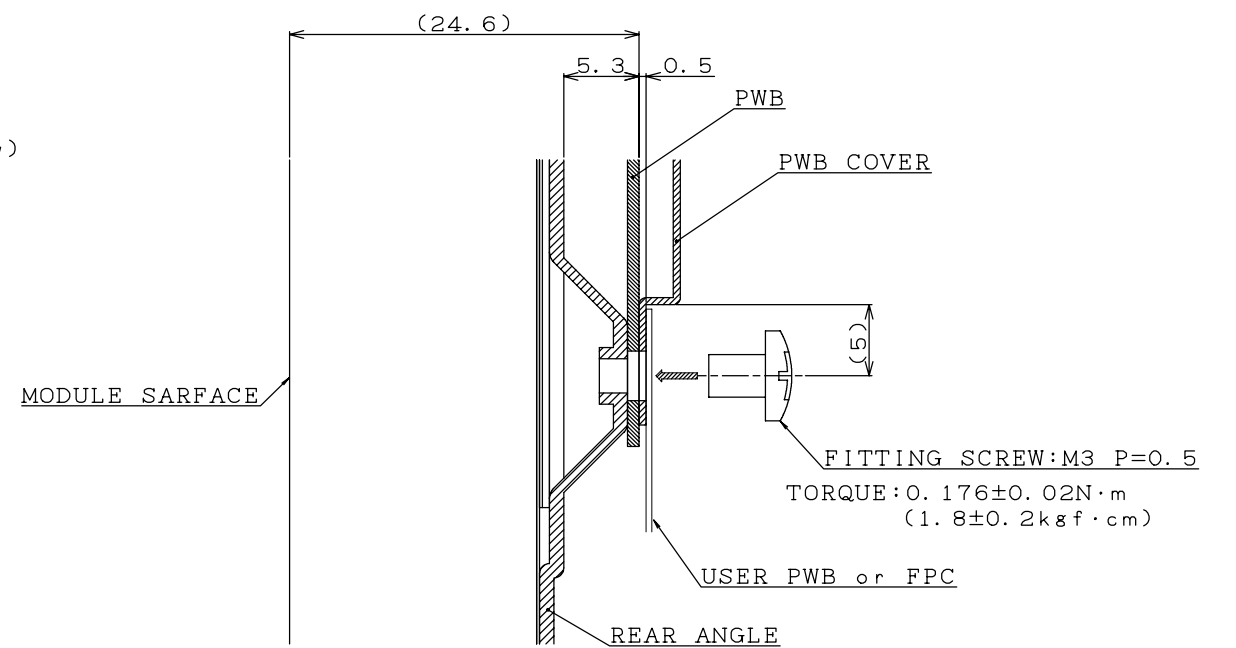

SECTION C-C'

20.1" UXGA TFT MODULE OUTLINE DIMENSIONS

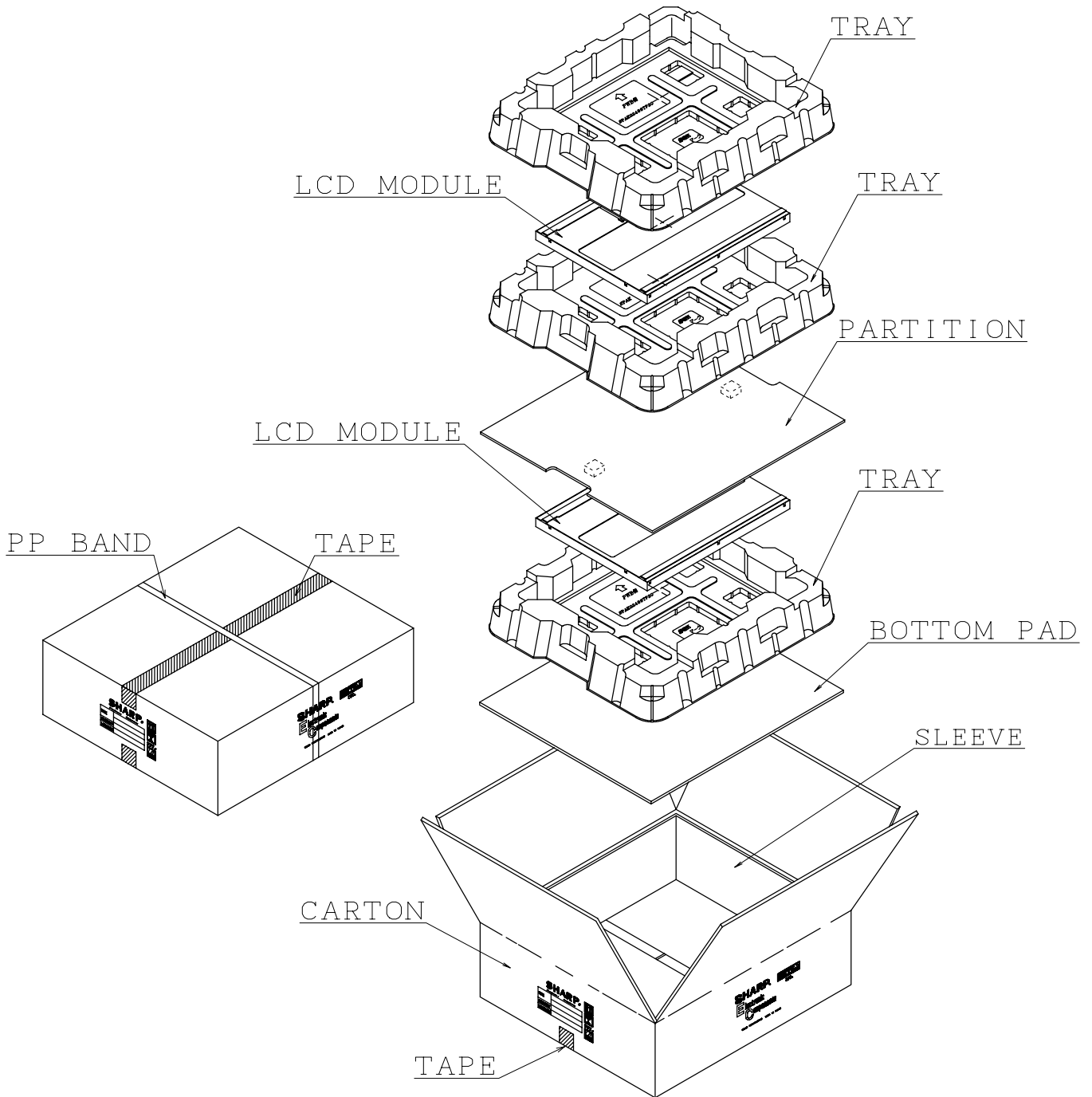

<Packing Form>

SPECIFICATIONS ARE SUBJECT TO CHANGE WITHOUT NOTICE.

Suggested applications (if any) are for standard use; See Important Restrictions for limitations on special applications. See Limited Warranty for SHARP's product warranty. The Limited Warranty is in lieu, and exclusive of, all other warranties, express or implied. ALL EXPRESS AND IMPLIED WARRANTIES, INCLUDING THE WARRANTIES OF MERCHANTABILITY, FITNESS FOR USE AND FITNESS FOR A PARTICULAR PURPOSE, ARE SPECIFICALLY EXCLUDED. In no event will SHARP be liable, or in any way responsible, for any incidental or consequential economic or property damage.

SHARP®

NORTH AMERICA

SHARP Microelectronics of the Americas
5700 NW Pacific Rim Blvd.
Camas, WA 98607, U.S.A.
Phone: (1) 360-834-2500
Fax: (1) 360-834-8903
Fast Info: (1) 800-833-9437
www.sharpsma.com

EUROPE

SHARP Microelectronics Europe
Division of Sharp Electronics (Europe) GmbH
Sonninstrasse 3
20097 Hamburg, Germany
Phone: (49) 40-2376-2286
Fax: (49) 40-2376-2232
www.sharpsme.com

JAPAN

SHARP Corporation
Electronic Components & Devices
22-22 Nagaike-cho, Abeno-Ku
Osaka 545-8522, Japan
Phone: (81) 6-6621-1221
Fax: (81) 6117-725300/6117-725301
www.sharp-world.com

TAIWAN

SHARP Electronic Components
(Taiwan) Corporation
8F-A, No. 16, Sec. 4, Nanking E. Rd.
Taipei, Taiwan, Republic of China
Phone: (886) 2-2577-7341
Fax: (886) 2-2577-7326/2-2577-7328

SINGAPORE

SHARP Electronics (Singapore) PTE., Ltd.
438A, Alexandra Road, #05-01/02
Alexandra Technopark,
Singapore 119967
Phone: (65) 271-3566
Fax: (65) 271-3855

KOREA

SHARP Electronic Components
(Korea) Corporation
RM 501 Geosung B/D, 541
Dohwa-dong, Mapo-ku
Seoul 121-701, Korea
Phone: (82) 2-711-5813 ~ 8
Fax: (82) 2-711-5819

CHINA

SHARP Microelectronics of China
(Shanghai) Co., Ltd.
28 Xin Jin Qiao Road King Tower 16F
Pudong Shanghai, 201206 P.R. China
Phone: (86) 21-5854-7710/21-5834-6056
Fax: (86) 21-5854-4340/21-5834-6057

Head Office:

No. 360, Bashen Road,
Xin Development Bldg. 22
Waigaoqiao Free Trade Zone Shanghai
200131 P.R. China
Email: smc@china.global.sharp.co.jp

HONG KONG

SHARP-ROXY (Hong Kong) Ltd.
3rd Business Division,
17/F, Admiralty Centre, Tower 1
18 Harcourt Road, Hong Kong
Phone: (852) 28229311
Fax: (852) 28660779
www.sharp.com.hk

Shenzhen Representative Office:

Room 13B1, Tower C,
Electronics Science & Technology Building
Shen Nan Zhong Road
Shenzhen, P.R. China
Phone: (86) 755-3273731
Fax: (86) 755-3273735