



Product Description: T315HW02 TFT-LCD PANEL with RoHS guarantee

AUO Model Name: T315HW02 V0

Customer Part No/Project Name:

Customer Signature	Date	AUO	2008/09/10
		Approved By: PM Director / Frank Hsu	
		Reviewed By: RD Director / Hong Hong Jye Reviewed By: Project Leader / Jr Chiou	
		Prepared By: PM / Hanson Wang	



Document Version : 0.0

Date : 2008/9/10

Product Specifications

31.5" FHD Color TFT-LCD Module

Model Name: T315HW02 V0

(*) Preliminary Specifications

() Final Specifications



Contents

No	
	COVER
	CONTENTS
	RECORD OF REVISIONS
1	GENERAL DESCRIPTION
2	ABSOLUTE MAXIMUM RATINGS
3	ELECTRICAL SPECIFICATIONS
4	BACKLIGHT CONNECTOR PIN CONFIGURATIO
5	OPTICAL SPECIFICATIONS
6	MECHANICAL CHARACTERISTICS
7	RELIABLITY
8	INTERNATIONAL STANDARDS
9	PACKING
10	PRECAUTIONS



Record of Revision

Version	Date	No	Old Description	New Description	Remark
0	2007/12/26		First issue		



1. General Description

This specification applies to the 31.5 inch Color TFT-LCD Module T315HW02 V0. This LCD module has a TFT active matrix type liquid crystal panel 1920x1080 pixels, and diagonal size of 31.5 inch. This module supports 1920x1080 HDTV mode (Non-interlace).

Each pixel is divided into Red, Green and Blue sub-pixels or dots which are arranged in vertical stripes. Gray scale or the brightness of the sub-pixel color is determined with a 8-bit gray scale signal for each dot.

The T315HW02 V0 has been designed to apply the 8-bit 1 channel LVDS interface method. It is intended to support displays where high brightness, wide viewing angle, high color saturation, and high color depth are very important.

The T315HW02 V0 model is RoHS verified which can be distinguished on panel label.

* General Information

Items	Specification	Unit	Note
Active Screen Size	31.51 inches		
Display Area	698.4 (H) x 392.85 (V)	mm	
Outline Dimension	760.0(H) x 450.0(V) x 45(D)	mm	With inverter
Driver Element	a-Si TFT active matrix		
Display Colors	16.7M	Colors	
Number of Pixels	1920x1080	Pixel	
Pixel Pitch	0.36375	mm	
Pixel Arrangement	RGB vertical stripe		
Display Mode	Normally Black		
Surface Treatment	AG, 3H		Haze = 11



2. Absolute Maximum Ratings

The following are maximum values which, if exceeded, may cause permanent damage to the unit.

Item	Symbol	Min	Max	Unit	Conditions
Logic/LCD Drive Voltage	Vcc	-0.3	14	[Volt]	Note 1
Input Voltage of Signal	Vin	-0.3	3.6	[Volt]	Note 1
BLU Input Voltage	VDDDB	-0.3	28	[Volt]	Note 1
BLU Brightness Control Voltage	Vdim	-0.3	7.0	[Volt]	Note 1
Operating Temperature	TOP	0	+50	[°C]	Note 2
Operating Humidity	HOP	10	90	[%RH]	Note 2
Storage Temperature	TST	-20	+60	[°C]	Note 2
Storage Humidity	HST	10	90	[%RH]	Note 2
Panel Surface Temperature	PST		65	[°C]	

Note 1: Duration:50 msec.

Note 2 : Maximum Wet-Bulb should be 39°C and No condensation.

The relative humidity must not exceed 90% non-condensing at temperatures of 40°C or less. At temperatures greater than 40°C, the wet bulb temperature must not exceed 39°C.

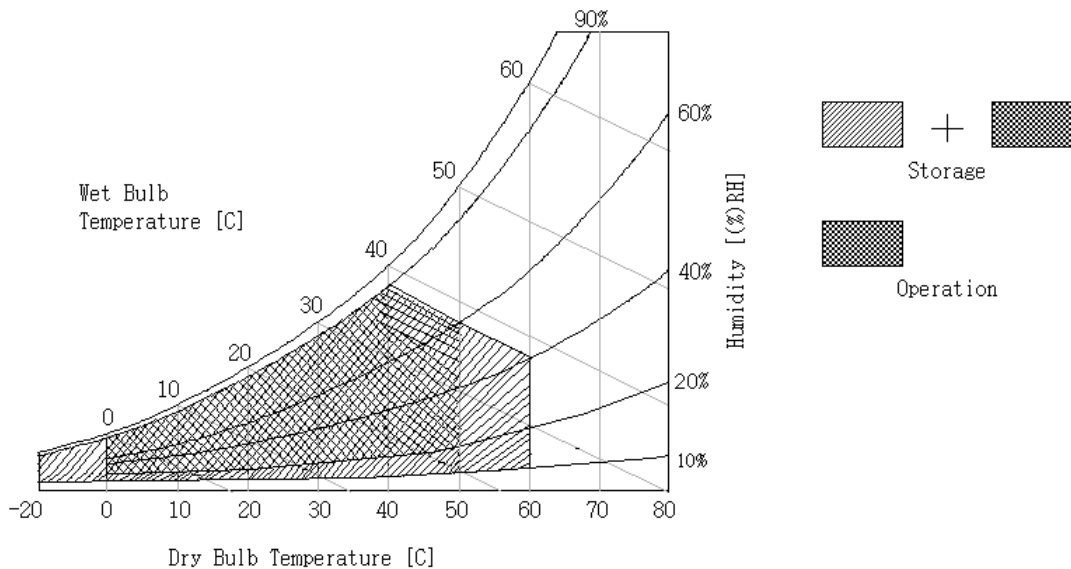

3. Electrical Specification

The T315HW02 V0 requires two power inputs. One is employed to power the LCD electronics and to drive the TFT array and liquid crystal. The second input power for the BLU, is to power inverter..

3-1 Electrical Characteristics

Parameter		Values			Unit	Notes	
		Min	Typ	Max			
CD:							
Power Supply Input Voltage		Vcc	10.8	12	13.2	Vdc	1
Power Supply Input Current		Icc	-	0.65	0.75	A	2
Power Consumption		Pc	-	7.8	9	Watt	2
Inrush Current		I _{RUSH}	-	-	6	Apeak	3
LVDS Interface	Differential Input High Threshold Voltage	VTH	100			mV	4
	Differential Input Low Threshold Voltage	VTL	100			mV	4
	Common Input Voltage	VCIM	1.10	1.25	1.40	V	4
CMOS Interface	Input High Threshold Voltage	V _{IH} (High)	2.4		3.3	Vdc	
	Input Low Threshold Voltage	V _{IL} (Low)	0		0.7	Vdc	
Backlight Power Consumption		P _{DDB}	63.5	67	70.5	Watt	
Life Time			50,000			Hours	6

Note :

1. The ripple voltage should be controlled under 10% of V_{CC}
2. V_{cc}=12.0V, $f_v = 60\text{Hz}$, $f_{\text{CLK}}=81.5\text{Mhz}$, 25°C, Test Pattern : White Pattern
3. Measurement condition :

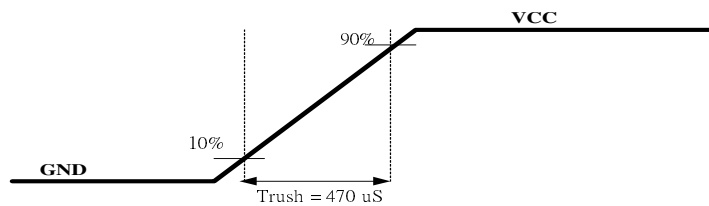



4. VCIM = 1.2V

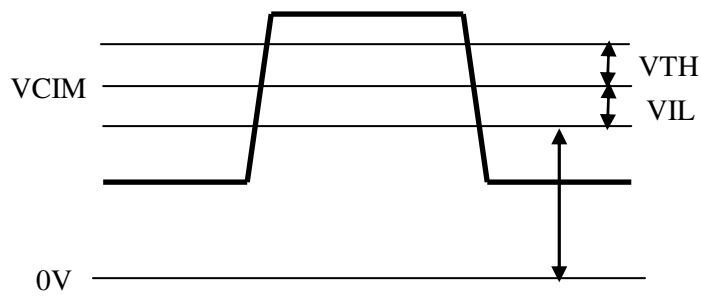

5. Do not attach a conducting tape to lamp connecting wire. If the lamp wire attach to conducting tape, TFT-LCD Module have a low luminance and the inverter has abnormal action because leakage current occurs between lamp wire and conducting tape.
6. The relative humidity must not exceed 80% non-condensing at temperatures of 40°C or less. At temperatures greater than 40°C, the wet bulb temperature must not exceed 39°C. When operate at low temperatures, the brightness of CCFL will drop and the life time of CCFL will be reduced.



3-2 Interface Connections

- Connector on Panel: JAE FI-RE51S-HF (Manufactured by JAE)

Pin No	Symboal	Description	Pin No	Symboal	Description
1	VCC	+12V, DC, Regulated	27	RE[1]-	Even LVDS Signal -
2	VCC	+12V, DC, Regulated	28	RE[1]+	Even LVDS Signal +
3	VCC	+12V, DC, Regulated	29	RE[2]-	Even LVDS Signal -
4	VCC	+12V, DC, Regulated	30	RE[2]+	Even LVDS Signal +
5	VCC	+12V, DC, Regulated	31	GND	Ground and Signal Return
6	GND	Ground and Signal Return	32	RECLK-	Even LVDS Clock -
7	GND	Ground and Signal Return	33	RECLK+	Even LVDS Clock +
8	GND	Ground and Signal Return	34	GND	Ground and Signal Return
9	GND	Ground and Signal Return	35	RE[3]-	Even LVDS Signal -
10	RO[0]-	Odd LVDS Signal -	36	RE[3]+	Even LVDS Signal +
11	RO[0]+	Odd LVDS Signal +	37	Reserved	Please leave it open
12	RO[1]-	Odd LVDS Signal -	38	Reserved	Please leave it open
13	RO[1]+	Odd LVDS Signal +	39	GND	Ground and Signal Return
14	RO[2]-	Odd LVDS Signal -	40	Reserved	Please leave it open
15	RO[2]+	Odd LVDS Signal +	41	Reserved	Please leave it open
16	GND	Ground and Signal Return	42	Reserved	Please leave it open
17	ROCLK-	Odd LVDS Signal -	43	Reserved	Please leave it open
18	ROCLK+	Odd LVDS Signal +	44	Reserved	Please leave it open
19	GND	Ground and Signal Return	45	LVDS Option	High/Open for Normal (NS), Low for JEIDA
20	RO[3]-	Odd LVDS Signal -	46	Reserved	Please leave it open
21	RO[3]+	Odd LVDS Signal +	47	Reserved	Please leave it open
22	Reserved	Please leave it open	48	Reserved	Please leave it open
23	Reserved	Please leave it open	49	Reserved	Please leave it open
24	GND	Ground and Signal Return	50	Reserved	Please leave it open
25	RE[0]-	Even LVDS Signal -	51	Reserved	Please leave it open
26	RE[0]+	Even LVDS Signal +			

Note:

1. All GND (ground) pins should be connected together and should also be connected to the LCD's metal frame.
All Vcc (power input) pins should be connected together.
2. For Pin 10, 27 and 28, panel will not damage if negligently connect these pins to high or low

LVDS Option = High/Open, NS mode

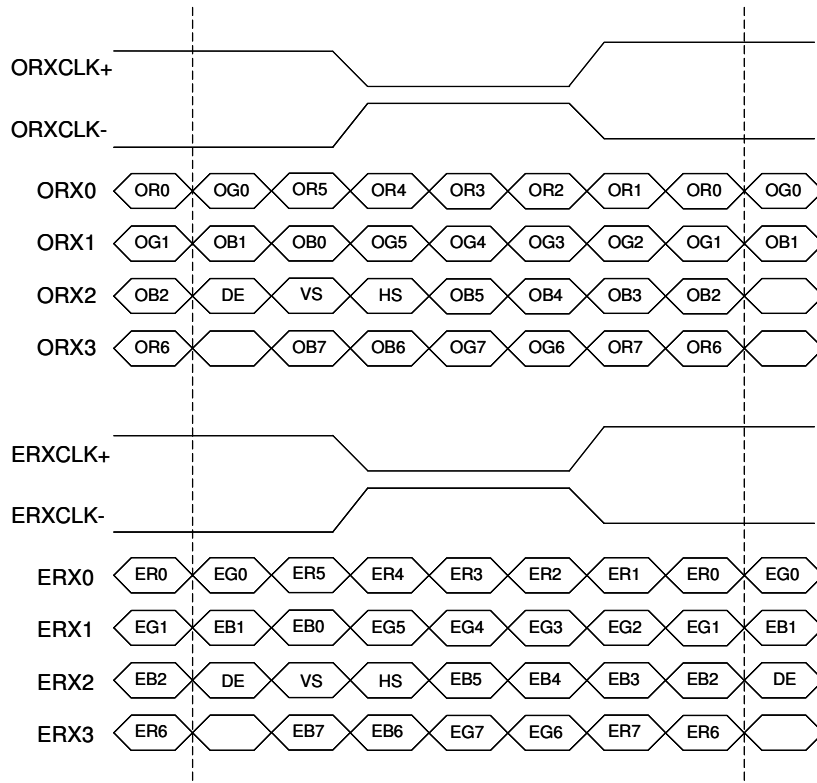

Note:

- ◆ Odd data is the first priority.
- ◆ First data is odd.

LVDS Option = Low (0V) , JEIDA mode

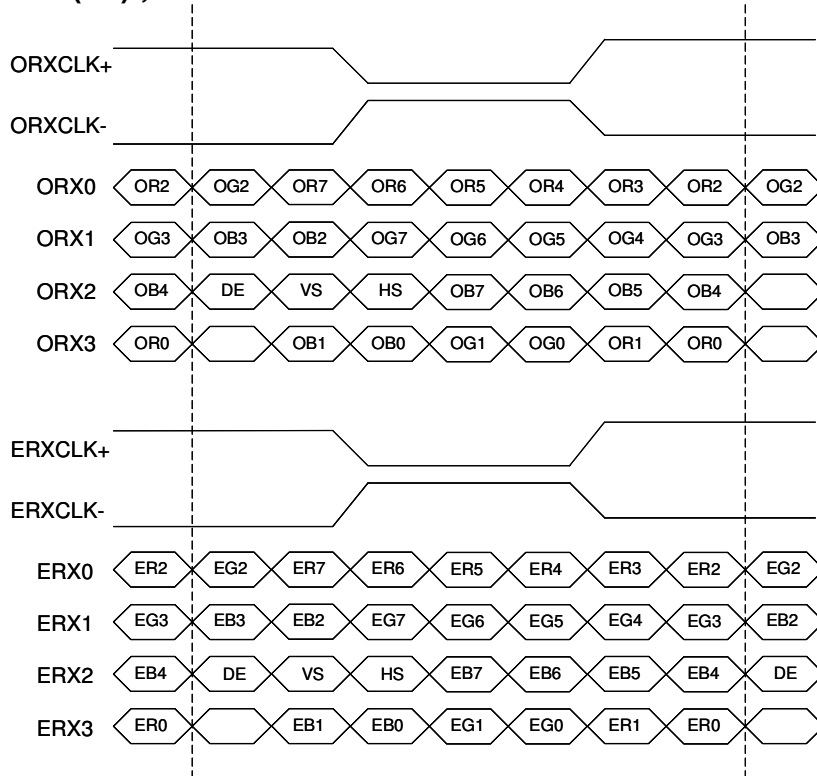



4. BACKLIGHT CONNECTOR PIN CONFIGURATION -

4-1 Electrical specification

Item	Symb.	Condition	Spec			Unit	Note
			Min	Typ	Max		
Input Voltage	VDDB	---	21.6	24.0	26.4	VDC	
Input Current (Turn on condition)	IDDB	VDDB=24V	2.78	2.93	3.10	ADC	1
Input Power (Turn on condition)	PDDB	VDDB=24V	--	70.3	74.4	W	1
Input Current (Stable condition)	IDDB	VDDB=24V		2.79		ADC	1
Input Power (Stable condition)	PDDB	VDDB=24V		67.0		W	1
Inrush Current	IRUSH	VDDB=24V	---	---	6.0	ADC	1,2
On/Off Control Voltage	VBLON	ON	VDDB=24V	2.0	---	5.0	VDC
		OFF	VDDB=24V	0.0	---	0.8	
On/Off Control Current	IBLON	VDDB=24V	0.0	---	1.5	mADC	
Dimming Control Voltage	VDIM	MAX	VDDB=24V	---	3.3	---	VDC
		MIN	VDDB=24V	---	0.0	---	
Dimming Control Current	I_DIM	MIN	VDDB=24V	---	---	1.5	mADC
Internal Dimming Ratio	DIM_R		---	10		100	%
PWM Function	V_PWM	MAX	---	2.0	---	5.0	VDC
		MIN	---	0.0	---	0.8	
External PWM Control Current	I_EPWM	---	---	---	1.5	mADC	
External PWM Ratio (Brightness)	D_EPWM	---	10	---	100	%	3
External PWM Frequency	F_EPWM	---	120	180	240	Hz	

Note 1 : VDIM= 3.3V (MAX) (Ta=25±5°C, Turn on for 45minutes)

Note 2 : Measurement condition Rising time = 20 ms (VDDB : 10%~90%);

Note 3 : (a) Uniformity and flicker does not guarantee below 20% dimming control
(b) 10% dimming control is function okay and no backlight shut down

4-2 Input specification

CN1: CI0114M1HRL-LF (Civilux) ; CN2: CO042EP1MFA-LF (Civilux)

Pin No	Symbol	Description	Default
Pin No	Symbol	Description	24V
1	VDDB(main power)	DC input 24V VDC	24V
2	VDDB(main power)	DC input 24V VDC	24V
3	VDDB(main power)	DC input 24V VDC	24V
4	VDDB(main power)	DC input 24V VDC	24V
5	VDDB(main power)	DC input 24V VDC	24V
6	GND	Ground	GND
7	GND	Ground	GND
8	GND	Ground	GND
9	GND	Ground	GND
10	GND	Ground	GND
11	Panel DET	Panel status detect Inverter OK: Low/GND (0-0.8V) Inverter NG: open collector	-
12	VBLON	BL on-off : high/open(3.3 ~ 5V) for BL on, low(GND) for BL off	-
13	VDIM (LCD Bright)	VDIM: Internal PWM Dimming control signal input (DC 0~3.3V) (3.3V : Maximum brightness, 0V min brightness) < NC ; when External PWM >	-
14	PDIM (LCD Bright)	PDIM: External PWM Dimming control signal input (AC 0~3.3V, Duty: 20%~100%) < NC ; when internal PWM >	-



4-3 Signal Timing Specifications

This is the signal timing required at the input of the User connector. All of the interface signal timing should be satisfied with the following specifications for its proper operation.

Timing Table (DE only Mode)

Signal	Item	Symbol	Min.	Typ.	Max.	Unit
Vertical Section	Period	Tv	1090	1125	1480	Th
	Active	Tdisp(v)	1080			Th
	Blanking	Tblk (v)	10	45	400	Th
Horizontal Section	Period	Th	1030	1100	1300	Tclk
	Active	Tdisp(h)	960			Tclk
	Blanking	Tblk (h)	70	140	340	Tclk
LVDS Clock	Frequency	Fclk (1/Tclk)	50	74.25	82	MHz
Vertical Frequency	Frequency	Fv	47	60	63	Hz
Horizontal Frequency	Frequency	Fh	60	67.5	73	kHz

Note : Water flow issue need to be confirmed under some frequency

- 1.) Display position is specific by the rise of DE signal only.
- Horizontal display position is specified by the falling edge of 1st DCLK right after the rise of ENAB, is displayed on the left edge of the screen.
- Vertical display position is specified by the rise of DE after a “Low” level period equivalent to eight times of horizontal period. The 1st data corresponding to one horizontal line after the rise the of ENAB is displayed at the top line of screen.
- 3.) If a period of DEB “High” is less than 1920 DCLK or less than 1080 lines, the rest of the screen displays black.
- 4.) The display position does not fit to the screen if a period of DE “High” and the effective data period do not synchronize with each other.



4-4 Signal Timing Waveforms

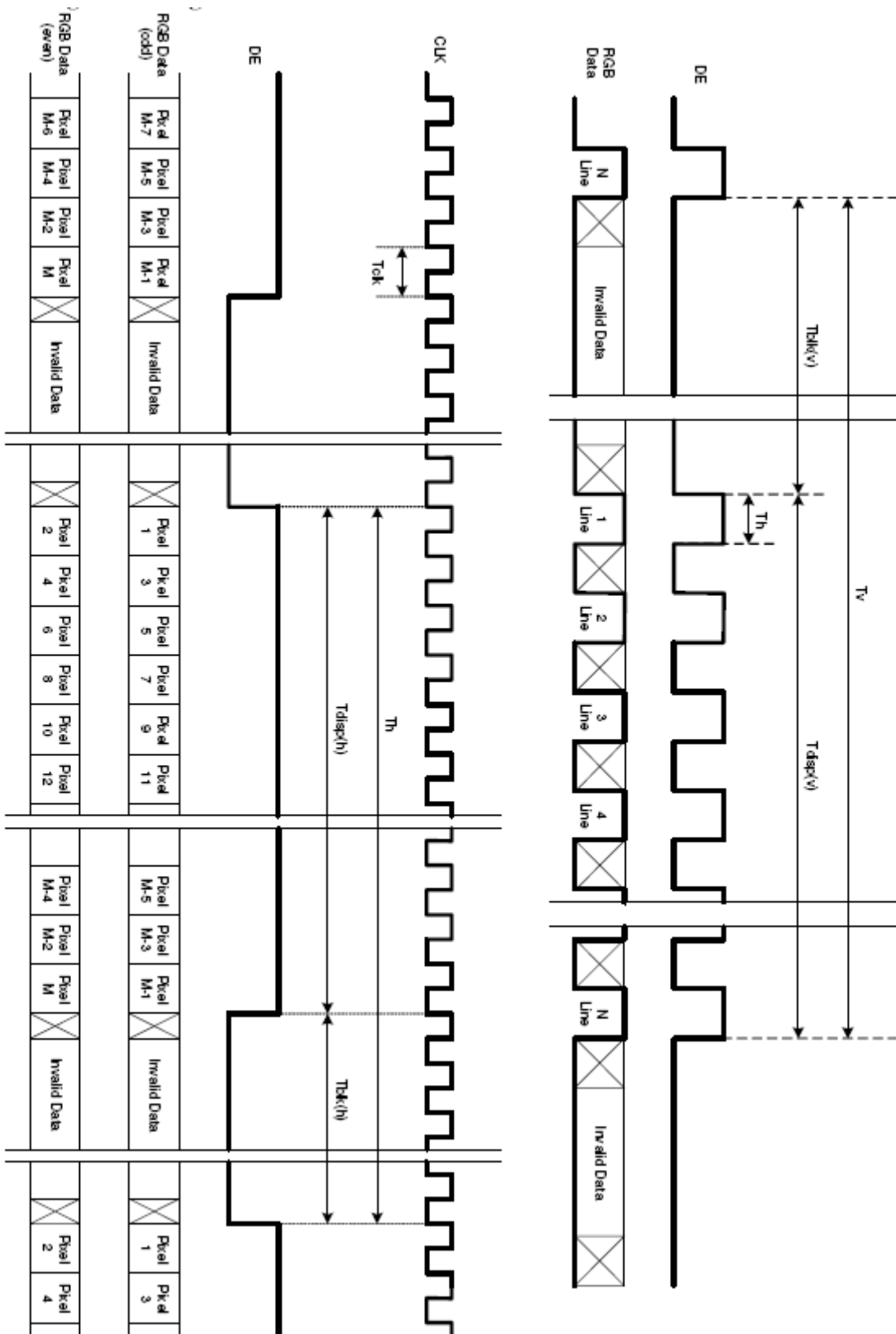



4-5 Color Input Data Reference

The brightness of each primary color (red, green and blue) is based on the 8 bit gray scale data input for the color; the higher the binary input, the brighter the color. The table below provides a reference for color versus data input.

COLOR DATA REFERENCE

Color		Input Color Data																							
		RED								GREEN								BLUE							
		MSB				LSB				MSB				LSB				MSB				LSB			
		R7	R6	R5	R4	R3	R2	R1	R0	G7	G6	G5	G4	G3	G2	G1	G0	B7	B6	B5	B4	B3	B2	B1	B0
Basic Color	Black	0	0	0	0	0	0	0	0	0	0	0	0	0	0	0	0	0	0	0	0	0	0	0	0
	Red(255)	1	1	1	1	1	1	1	1	0	0	0	0	0	0	0	0	0	0	0	0	0	0	0	0
	Green(255)	0	0	0	0	0	0	0	0	1	1	1	1	1	1	1	1	0	0	0	0	0	0	0	0
	Blue(255)	0	0	0	0	0	0	0	0	0	0	0	0	0	0	0	0	1	1	1	1	1	1	1	1
	Cyan	0	0	0	0	0	0	0	0	1	1	1	1	1	1	1	1	1	1	1	1	1	1	1	1
	Magenta	1	1	1	1	1	1	1	1	0	0	0	0	0	0	0	0	1	1	1	1	1	1	1	1
	Yellow	1	1	1	1	1	1	1	1	1	1	1	1	1	1	1	1	0	0	0	0	0	0	0	0
	White	1	1	1	1	1	1	1	1	1	1	1	1	1	1	1	1	1	1	1	1	1	1	1	1
RED	RED(000)	0	0	0	0	0	0	0	0	0	0	0	0	0	0	0	0	0	0	0	0	0	0	0	0
	RED(001)	0	0	0	0	0	0	0	1	0	0	0	0	0	0	0	0	0	0	0	0	0	0	0	0

	RED(254)	1	1	1	1	1	1	1	0	0	0	0	0	0	0	0	0	0	0	0	0	0	0	0	0
	RED(255)	1	1	1	1	1	1	1	1	0	0	0	0	0	0	0	0	0	0	0	0	0	0	0	0
GREEN	GREEN(000)	0	0	0	0	0	0	0	0	0	0	0	0	0	0	0	0	0	0	0	0	0	0	0	0
	GREEN(001)	0	0	0	0	0	0	0	0	0	0	0	0	0	0	0	1	0	0	0	0	0	0	0	0

	GREEN(254)	0	0	0	0	0	0	0	0	1	1	1	1	1	1	1	0	0	0	0	0	0	0	0	0
	GREEN(255)	0	0	0	0	0	0	0	0	1	1	1	1	1	1	1	1	0	0	0	0	0	0	0	0
BLUE	BLUE(000)	0	0	0	0	0	0	0	0	0	0	0	0	0	0	0	0	0	0	0	0	0	0	0	0
	BLUE(001)	0	0	0	0	0	0	0	0	0	0	0	0	0	0	0	0	0	0	0	0	0	0	0	1

	BLUE(254)	0	0	0	0	0	0	0	0	0	0	0	0	0	0	0	0	1	1	1	1	1	1	1	0
	BLUE(255)	0	0	0	0	0	0	0	0	0	0	0	0	0	0	0	0	1	1	1	1	1	1	1	1



4-6 Power Sequence for LCD Module

4.6.1 Power Sequence for LCD

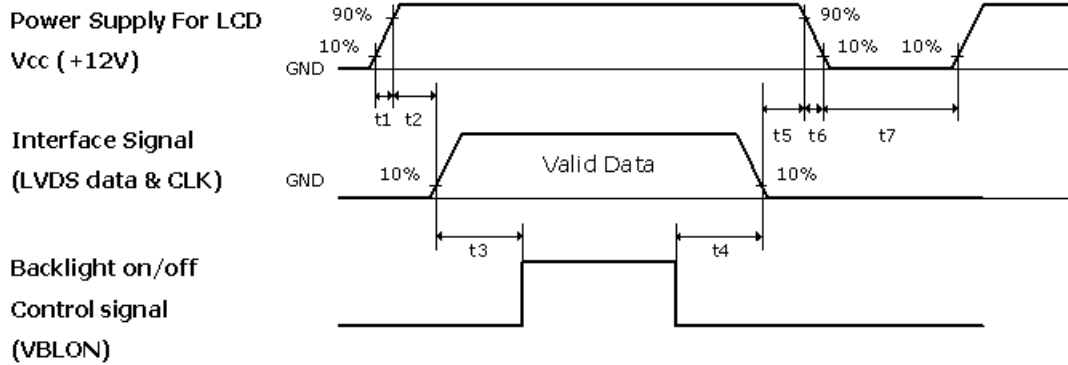

Parameter	Values			Units
	Min.	Typ.	Max.	
t1	0.4	---	30	ms
t2	0.1	---	50	ms
t3	300	---	---	ms
t4	10	---	---	ms
t5	0.1	---	50	ms
t6	---	---	300	ms
t7	500	---	---	s

Note:

The timing controller will not be damaged in case of TV set AC input power suddenly shut down.

Once power reset, it should follow power sequence as spec. definition.

- (1) Apply the lamp voltage within the LCD operation range. When the back-light turns on before the LCD operation or the LCD turns off before the back-light turns off, the display may momentarily become abnormal screen.



4.6.2 Power Sequence for Inverter

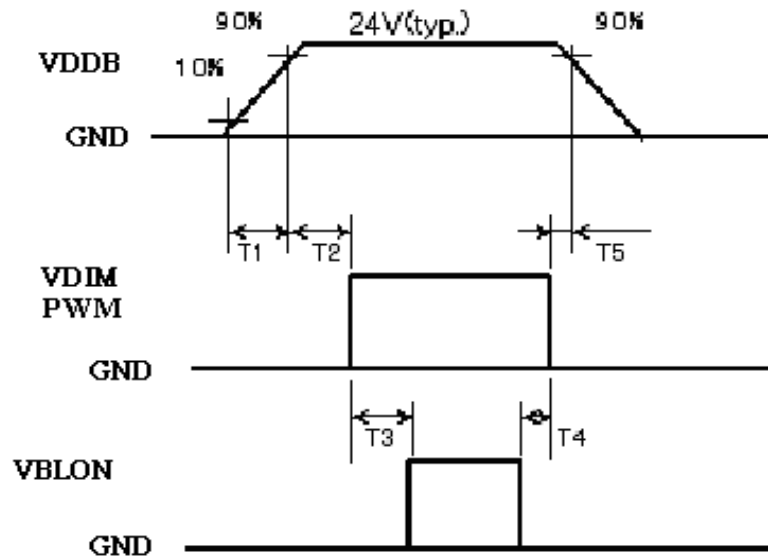

Deep condition for Inverter

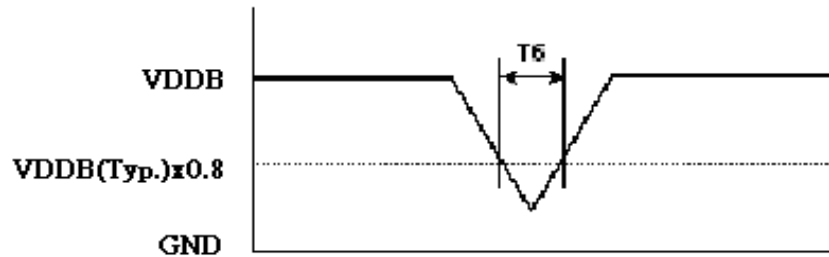

Parameter	Values			Units
	Min.	Typ.	Max.	
T1	20	-	-	Ms
T2	50	-	-	Ms
T3	0	-	-	Ms
T4	0	-	-	Ms
T5	0	-	-	Ms
T6	-	-	10	Ms

5. Optical Specification

Optical characteristics are determined after the unit has been 'ON' and stable for approximately 45 minutes in a dark environment at 25°C. The values specified are at an approximate distance 50cm from the LCD surface at a viewing angle of Φ and θ equal to 0°.

Fig.1 1 presents additional information concerning the measurement equipment and method.

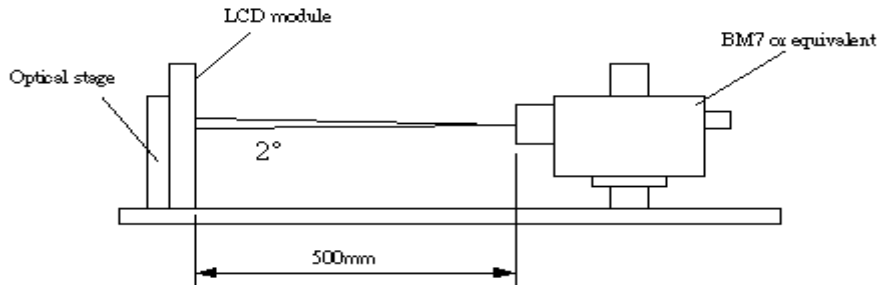

Parameter	Symbol	Values			Units	Notes
		Min.	Typ.	Max.		
Contrast Ratio	CR	2000	4000			1
Surface Luminance, white	LWH	400	500		cd/m ²	2
Luminance Variation	δ_{WHITE} 9 p			1.30		3
Response time G to G	T γ		6.5		ms	4
Color Gamut	NTSC		72		%	
Gamma			2.2			
Color Coordinates						
	RED	R _X	0.64	Typ.-0.03	Typ.+0.03	
		R _Y	0.33			
	GREEN	G _X	0.29			
		G _Y	0.60			
	BLUE	B _X	0.15			
		B _Y	0.06			
	WHITE	W _X	0.28			
		W _Y	0.29			
Viewing Angle						
	x axis, right($\varphi=0^\circ$)	θ_r	89		degree	5
	x axis, left($\varphi=180^\circ$)	θ_l	89			
	y axis, up($\varphi=90^\circ$)	θ_u	89			
	y axis, down ($\varphi=0^\circ$)	θ_d	89			

Note:

1. Contrast Ratio (CR) is defined mathematically as:

$$\text{Contrast Ratio} = \frac{\text{Surface Luminance of } L_{\text{on5}}}{\text{Surface Luminance of } L_{\text{off5}}}$$

2. Surface luminance is luminance value at point 5 across the LCD surface 50cm from the surface with all pixels displaying white. From more information see FIG 2. When $V_{\text{DDB}} = 24\text{V}$, $I_{\text{DDB}} = 5\text{A}$. $L_{\text{WH}} = L_{\text{on1}}$

Where L_{on1} is the luminance with all pixels displaying white at center 1 location.

3. The variation in surface luminance, δ_{WHITE} is defined (center of Screen) as:

$$\delta_{\text{WHITE(9P)}} = \frac{\text{Maximum}(L_{\text{on1}}, L_{\text{on2}}, \dots, L_{\text{on9}})}{\text{Minimum}(L_{\text{on1}}, L_{\text{on2}}, \dots, L_{\text{on9}})}$$

4. Response time T_{γ} is the average time required for display transition by switching the input signal for five luminance ratio (0%,25%,50%,75%,100% brightness matrix) and is based on $f_v = 60\text{Hz}$ to optimize.

	0%	25%	50%	75%	100%
0%		t:0%-25%	t:0%-50%	t:0%-75%	t:0%-100%
25%	t:25%-0%		t:25%-50%	t:25%-75%	t:25%-100%
50%	t:50%-0%	t:50%-25%		t:50%-75%	t:50%-100%
75%	t:75%-0%	t:75%-25%	t:75%-50%		t:50%-100%
100%	t:100%-0%	t:100%-25%	t:100%-50%	t:100%-75%	

5. Viewing angle is the angle at which the contrast ratio is greater than 10. The angles are determined for the horizontal or x axis and the vertical or y axis with respect to the z axis which is normal to the LCD surface. For more information see FIG4.

FIG. 2 Luminance

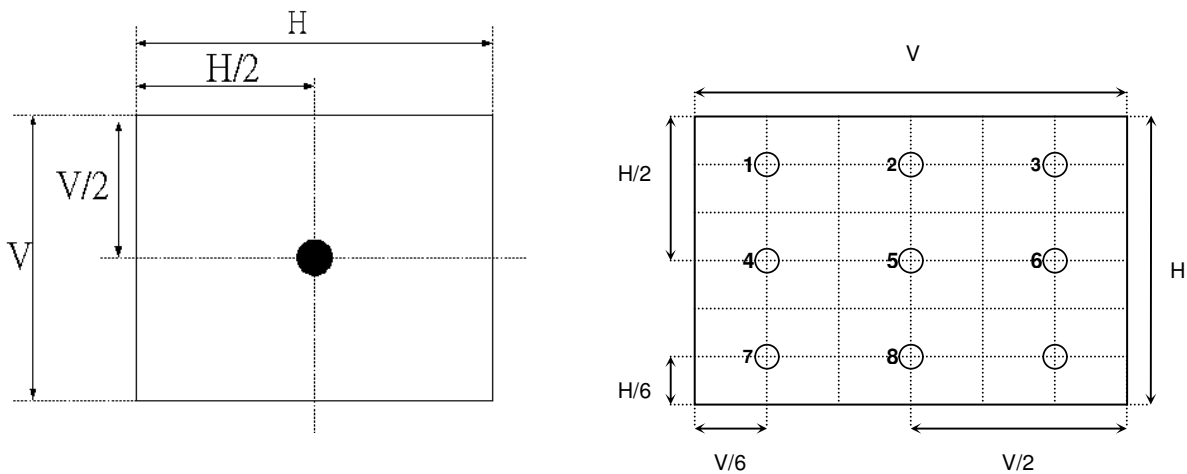



FIG.3 Response Time

The response time is defined as the following figure and shall be measured by switching the input signal for “any level of gray(bright)” and “any level of gray(dark)”.

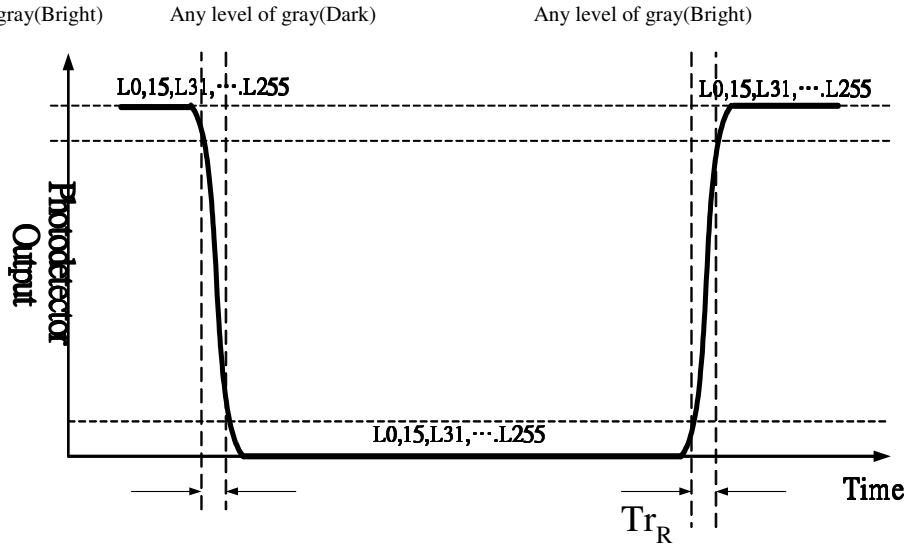
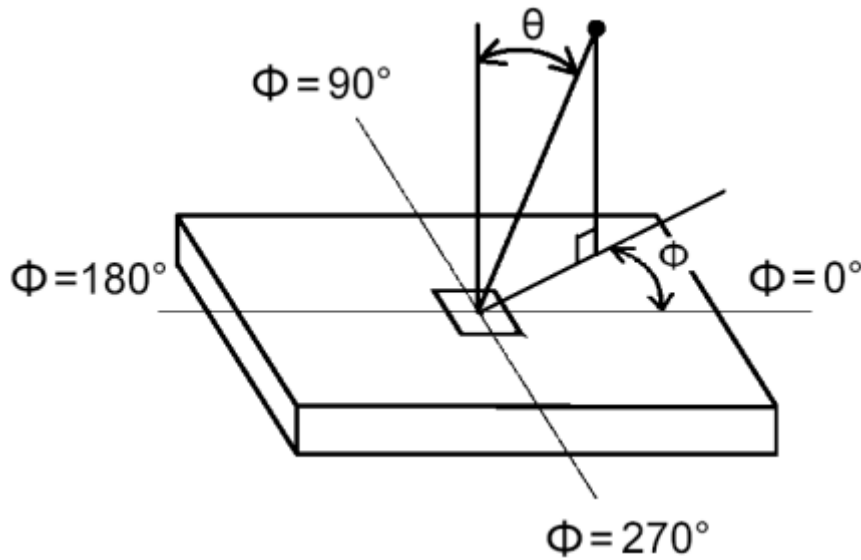

FIG.4 Viewing angle





6. Mechanical Characteristics

The contents provide general mechanical characteristics for the model T315HW02 V0. In addition the figures in the next page are detailed mechanical drawing of the LCD.

Outline Dimension	Horizontal	760.0mm
	Vertical	450.0mm
	Depth	45mm
Bezel Opening	Horizontal	703.6mm
	Vertical	398.4mm
Active Display Area	Horizontal	698.4mm
	Vertical	392.85mm
Weight	6500g Typ.	
Surface Treatment	AG, 3H, Haze=11%	



7. Reliability:

Environment test condition

	Test Items	Q'ty	Conditions
1	High Temperature Stroage	3	60°C 300 hrs
2	Low Temperature Stroage	3	-20°C, 300 hrs
3	High Temperature Operation	3	50°C, 300 hrs
4	Low Temperature Operation	3	-5°C, 300 hrs
5	Vibration (non-operation)	3	(10 ~ 300Hz/1.5G/11min SR, XYZ 30min/axis) Vibration level : 1.5G RMS, Bandwidth : 10-300Hz Duration: X, Y, Z 30min,
6	Shock (non-operation)	3	Shock level: 50G Waveform: have sine wave, 11ms Direction: $\pm X, \pm Y, \pm Z$ One time each direction
7	Vibration (With carton)	3	Random wave (1.5 Grms 10~200Hz) 30mins / Per each X.Y.Z axes
8	Drop (With carton)	3	Height: 46cm 1 corner, 3 edges, 6 surfaces (ASTMD4169-I)



8. International Standard

8-1. Safety

- i. UL1950 Third Edition, Underwriters Laboratories, Inc. Jan. 28, 1995
Standard for Safety of Information Technology Equipment Including electrical Business Equipment.
- ii. CAN/CSA C22.2 No. 950-95/60950 Third Edition, Canadian Standards Association,
Standard for Safety of Information Technology Equipment Including Electrical Business Equipment.
- iii. EN60950 : 1992+A2: 1993+A2: 1993+C3: 1995+A4: 1997+A11: 1997
IEC 950: 1991+A1: 1992+A2: 1993+C3: 1995+A4:1996
European Committee for Electrotechnical Standardization (CENELEC)
EUROPEAN STANDARD for Safety of Information Technology Equipment Including Electrical Business
Equipment.

8-2. EMC

- a) ANSI C63.4 “Methods of Measurement of Radio-Noise Emissions from Low-Voltage Electrical and Electrical Equipment in the Range of 9kHz to 40GHz. “American National standards Institute(ANSI), 1992
- b) C.I.S.P.R “Limits and Methods of Measurement of Radio Interface Characteristics of Information Technology Equipment.” International Special committee on Radio Interference.
- c) EN 55022 “Limits and Methods of Measurement of Radio Interface Characteristics of Information Technology Equipment.” European Committee for Electrotechnical Standardization. (CENELEC), 1998



9. Packing

Panel label:



TW7A00400044-ZM0200

TW7A004: T: Taiwan, A/B: China

00044: Panel Serial Number

ZM0: AUO internal code

Manufactured 07/43: 2007 week 43

Made In Taiwan: Taiwan made

Carton Label:

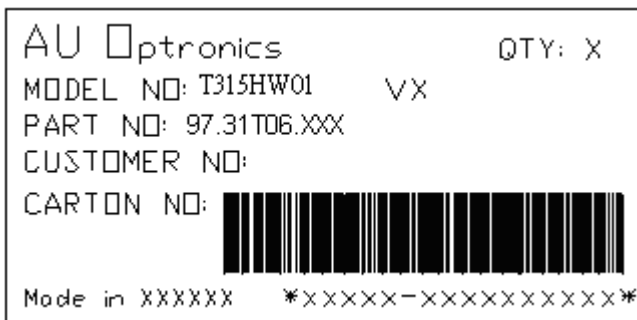



10. PRECAUTIONS

Please pay attention to the followings when you use this TFT LCD module.

10-1 MOUNTING PRECAUTIONS

- (1) You must mount a module using holes arranged in four corners or four sides.
- (2) You should consider the mounting structure so that uneven force (ex. Twisted stress) is not applied to module. And the case on which a module is mounted should have sufficient strength so that external force is not transmitted directly to the module.
- (3) Please attach the surface transparent protective plate to the surface in order to protect the polarizer. Transparent protective plate should have sufficient strength in order to resist external force.
- (4) You should adopt radiation structure to satisfy the temperature specification.
- (5) Acetic acid type and chlorine type materials for the cover case are not desirable because the former generates corrosive gas of attacking the polarizer at high temperature and the latter causes circuit break by electro-chemical reaction.
- (6) Do not touch, push or rub the exposed polarizers with glass, tweezers or anything harder than HB pencil lead. And please do not rub with dust clothes with chemical treatment. Do not touch the surface of polarizer for bare hand or greasy cloth. (Some cosmetics are detrimental to the polarizer.)
- (7) When the surface becomes dusty, please wipe gently with absorbent cotton or other soft materials like chamois soaks with petroleum benzene. Normal-hexane is recommended for cleaning the adhesives used to attach front/ rear polarizers. Do not use acetone, toluene and alcohol because they cause chemical damage to the polarizer.
- (8) Wipe off saliva or water drops as soon as possible. Their long time contact with polarizer causes deformations and color fading.
- (9) Do not open the case because inside circuits do not have sufficient strength.

10-2 OPERATING PRECAUTIONS

- (1) The device listed in the product specification sheets was designed and manufactured for TV application
- (2) The spike noise causes the mis-operation of circuits. It should be lower than following voltage:
 $V = \pm 200\text{mV}$ (Over and under shoot voltage)
- (3) Response time depends on the temperature. (In lower temperature, it becomes longer..)
- (4) Brightness depends on the temperature. (In lower temperature, it becomes lower.) And in lower temperature, response time (required time that brightness is stable after turned on) becomes longer.
- (5) Be careful for condensation at sudden temperature change. Condensation makes damage to polarizer or electrical contacted parts. And after fading condensation, smear or spot will occur.
- (6) When fixed patterns are displayed for a long time, remnant image is likely to occur.
- (7) Module has high frequency circuits. Sufficient suppression to the electromagnetic interference shall be done by system manufacturers. Grounding and shielding methods may be important to minimize the interface.



10-3 ELECTROSTATIC DISCHARGE CONTROL

Since a module is composed of electronic circuits, it is not strong to electrostatic discharge. Make certain that treatment persons are connected to ground through wrist band etc. And don't touch interface pin directly.

10-4 PRECAUTIONS FOR STRONG LIGHT EXPOSURE

Strong light exposure causes degradation of polarizer and color filter.

10-5 STORAGE +

When storing modules as spares for a long time, the following precautions are necessary.

- (1) Store them in a dark place. Do not expose the module to sunlight or fluorescent light. Keep the temperature between 5°C and 35°C at normal humidity.
- (2) The polarizer surface should not come in contact with any other object. It is recommended that they be stored in the container in which they were shipped.

10-6 HANDLING PRECAUTIONS FOR PROTECTION FILM

- (1) The protection film is attached to the bezel with a small masking tape. When the protection film is peeled off, static electricity is generated between the film and polarizer. This should be peeled off slowly and carefully by people who are electrically grounded and with well ion-blown equipment or in such a condition, etc.
- (2) When the module with protection film attached is stored for a long time, sometimes there remains a very small amount of flue still on the Bezel after the protection film is peeled off.
- (3) You can remove the glue easily. When the glue remains on the Bezel or its vestige is recognized, please wipe them off with absorbent cotton waste or other soft material like chamois soaked with normal-hexane.