



# SPECIFICATION FOR APPROVAL

( ◆ ) Preliminary Specification

(   ) Final Specification

Title	12.1" SVGA TFT LCD
-------	--------------------

BUYER	
MODEL	

SUPPLIER	LG LCD Inc.
MODEL	LB121S1-A2

SIGNATURE	DATE
/	
/	
/	

APPROVED BY	DATE
Y.K.Hwang / G.Manager	
REVIEWED BY B.K.Kim / Manager J.H.Lee / Manager	
PREPARED BY K.R.Jeong / Engineer E.Y.Ahn/ Engineer	

Please return 1 copy for your confirmation with your signature and comments.

Product Engineering Dept.  
LG LCD Inc.

## CONTENTS

NO.	ITEM	Page
-	COVER	1
-	CONTENTS	2
-	RECORD OF REVISION	3
1	GENERAL DESCRIPTION	4
2	MAXIMUM RATINGS	5
3	ELECTRICAL SPECIFICATIONS	6
3-1	ELECTRICAL CHARACTERISTICS	6
3-2	INTERFACE CONNECTION	7
3-3	SIGNAL TIMING SPECIFICATIONS	8
3-4	SIGNAL TIMING WAVE FORMS	9
3-5	COLOR INPUT DATA REFERENCE	10
3-6	POWER SEQUENCE	11
3-7	V <sub>cc</sub> DIP CONDITION	12
4	OPTICAL SPECIFICATIONS	13
5	MECHANICAL CHARACTERISTICS	14
6	RELIABILITY	17
7	INTERNATIONAL STANDARDS	18
7-1	SAFETY	18
7-2	EMC	18
8	PACKING	19
8-1	DESIGNATION OF LOT MARK	19
8-2	PACKING FORM	19
9	PRECAUTIONS	20
	APPENDIX	
A-1	OPTICAL CHARACTERISTIC MEASUREMENT EQUIPMENT AND METHOD	22
A-2	LUMINANCE	22
A-3	RESPONSE TIME	22
A-4	VIEWING ANGLE	23



**RECORDS OF REVISIONS**

Version No	Date	Page	DESCRIPTION
0.0	May.21.1999	-	First Draft

## 1. General Description

The LB121S1-A2 is a Color Active Matrix Liquid Crystal Display with an integral Cold Cathode Fluorescent Tube(CCFT) backlight system. The matrix employs a-Si Thin Film Transistor as the active element. It is a transmissive type display operating in the normally white mode. This TFT-LCD has a 12.1 inch diagonally measured active display area with SVGA resolution (600 vertical by 800 horizontal pixel array). Each pixel is divided into Red, Green and Blue sub-pixels or dots which are arranged in vertical stripes. Gray scale or the brightness of the sub-pixel color is determined with a 6-bit gray scale signal for each dot, thus presenting a palette of more than 262,144 colors.

The LB121S1-A2 is intended to support applications where high brightness, broad viewing angle are critical factors and graphic displays are important. In combination with the vertical arrangement of the sub-pixels, the LB121S1-A2 characteristics provide an excellent flat panel display for office automation products.

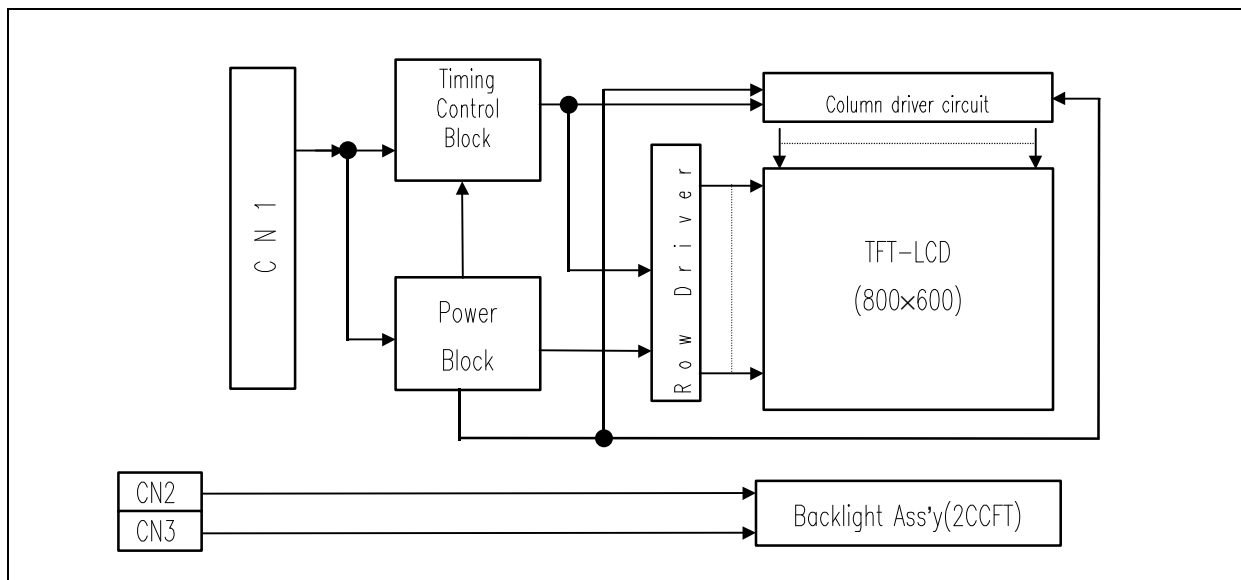

### General

### Features

The following are general feature of the model LB121S1-A2 LG LCD;

Active screen size	12.1 inches(30.75cm) diagonal
Outline dimensions	280(H) 218(V) 12(D) mm (typ)
Pixel pitch	0.3075 mm 0.3075 mm
Pixel format	800 horiz. By 600 vert. pixels
	RGB stripe arrangement
Color depth	6-bit, 262,144 colors
Luminance,White	300 cd/m <sup>2</sup> (typ)
Power Consumption	Total 8 Watt,typ (1Watt @Vcc, 7 Watt @Lamp)
Weight	795g (typ)
Display operating mode	transmissive mode, normally white
Surface treatments	hard coating(3H), anti-glare treatment of the front polarizer

**2. Maximum Ratings**

The following are maximum values which, if exceeded, may cause faulty operation or damage to the unit.

**Table 1 ABSOLUTE MAXIMUM RATINGS**

Parameter	symbol	Values		Units	Notes
		Min.	Max.		
Power Input Voltage	$V_{CC}$	-0.3	+3.6	Vdc	at 25°C
Operating Temperature	$T_{OP}$	0	+50	°C	1
Storage Temperature	$T_{ST}$	-20	+60	°C	1

Note: 1. Temperature and relative humidity range are shown in the figure below.

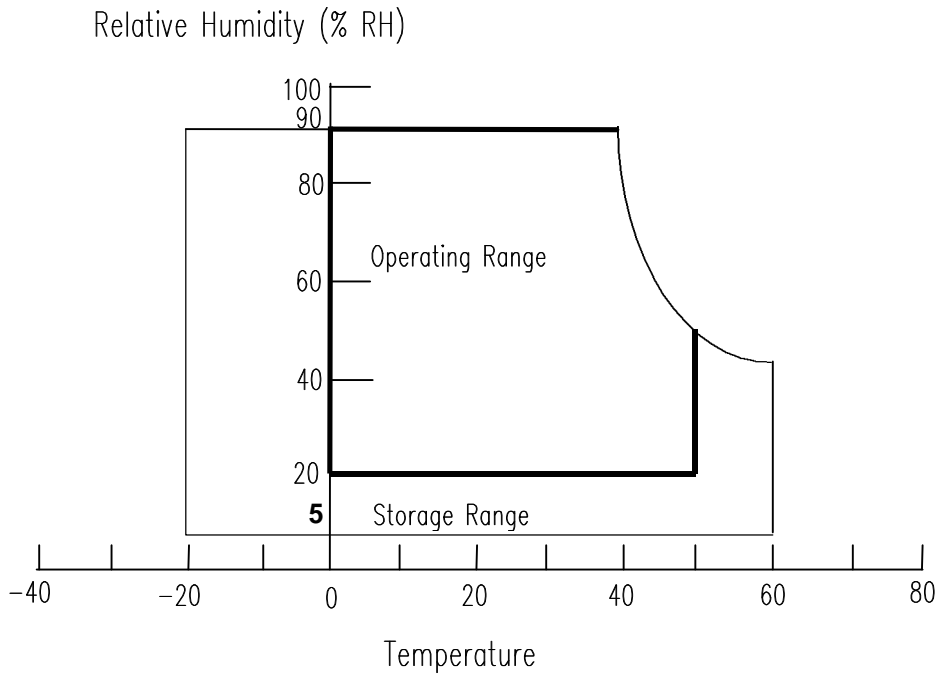

### 3. Electrical Specifications

#### 3-1. Electrical Characteristics

The LB121S1-A2 requires two power inputs. One is employed to power the LCD electronics and to drive the TFT array and liquid crystal. The second input which powers the CCFL, is typically generated by an inverter. The inverter is an external unit to the LCD.

Table 2 ELECTRICAL CHARACTERISTICS:

Parameter	Symbol	Values			Units	Notes
		Min.	Typ.	Max.		
<b>MODULE:</b>						
Power Supply Input Voltage	$V_{CC}$	3.0	3.3	3.6	Vdc	1
Power Supply Input Current	$I_{CC}$	-	0.310	0.355	A	
Power Consumption	$P_c$	-	1.0	1.2	Watts	1
Rush current	$I_{RUSH}$	-	tbd	tbd	A	2
<b>LAMP</b>						
Operating Voltage	$V_{BL}$	540	580	665	$V_{RMS}$	3
Operating Current	$I_{BL}$	3.0	6.0	8.0	mA	4
Established Starting Voltage at 25°C				875	$V_{RMS}$	
Established Starting Voltage at 0°C				1300	$V_{RMS}$	
Operating Frequency	$f_{BL}$	30	55	60	kHz	5
Power Consumption	$P_{BL}$	4.0	7.0	8.6	Watts	
Life Time		50,000	-		Hrs	6

- Notes:
1. The current draw and power consumption specified is for 3.3 Vdc at 25°C and fv at 60Hz. (at Black pattern displayed)
  2. The duration of rush current is about 20ms
  3. The variance of the voltage is 10%.
  4. The output voltage at the transformer in the inverter must be high considering to the loss of the ballast capacitor in the inverter.
  5. The lamp power consumption shown above does not include loss of external inverter.
  6. The life time is determined as the time at which brightness of lamp is 50% compare to that of initial value at the typical lamp current.

### 3-2. Interface Connections

This LCD employs three interface connections, a 41 pin connector is used for the module electronics and two connectors, a three pin connector, are used for the integral backlight system.

The electronics interface connector is a model DF9B-41P-1V manufactured by Hirose.

The pin configuration for the connector is shown in the table below.

**Table 3 MODULE CONNECTOR PIN CONFIGURATION**

Pin	Symbol	Description	Notes
1	Vss	Ground	Connect to Vss, see Note 1
2	CLK	Main clock	
3	Vss	Ground	Connect to Vss, see Note 1
4	Hsync	Horizontal sync.	
5	Vsync	Vertical sync.	
6	Vss	Ground	Connect to Vss, see Note 1
7	Vss	Ground	Connect to Vss, see Note 1
8	Vss	Ground	Connect to Vss, see Note 1
9	R0	Red data	Red data least significant bit(LSB)
10	R1	Red data	
11	R2	Red data	
12	Vss	Ground	Connect to Vss, see Note 1
13	R3	Red data	
14	R4	Red data	
15	R5	Red data	Red data most significant bit(MSB)
16	Vss	Ground	Connect to Vss, see Note 1
17	Vss	Ground	Connect to Vss, see Note 1
18	Vss	Ground	Connect to Vss, see Note 1
19	G0	Green data	Green data least significant bit(LSB)
20	G1	Green data	
21	G2	Green data	
22	Vss	Ground	
23	G3	Green data	
24	G4	Green data	
25	G5	Green data	Green data most significant bit(MSB)
26	Vss	Ground	Connect to Vss, see Note 1
27	Vss	Ground	Connect to Vss, see Note 1
28	Vss	Ground	Connect to Vss, see Note 1
29	B0	Blue data	Blue data least significant bit(LSB)
30	B1	Blue data	
31	B2	Blue data	
32	Vss	Ground	Connect to Vss, see Note 1
33	B3	Blue data	
34	B4	Blue data	
35	B5	Blue data	Blue data most significant bit(MSB)
36	Vss	Ground	Connect to Vss, see Note 1
37	DTMG	Data timing signal	
38	(NC)	No connection	
39	VCC	Power input	+3.3Vdc power supply input, see Note 2
40	VCC	Power input	+3.3Vdc power supply input, see Note 2
41	(NC)	No connection	

Notes: 1. All GND(ground) pins should be connected together and the LCD's metal frame.

2. All Vcc(power input) pins should be connected together.

The backlight interface connector is a model BHR-03VS-1, manufactured by JST. The mating connector part number is SM02(8.0)B-BHS-1-TB or equivalent. The pin configuration for the connector is shown in the table below.

**Table 4 BACKLIGHT CONNECTOR PIN CONFIGURATION**

Pin	Symbol	Description	Notes
1	HV	Lamp power input	PINK
2	NC	No connect	
3	LV	Ground	WHITE

Notes: 1. The input power terminal is colored pink. Ground pin color is white.

2. The lamp ground should be common with GND.

### 3-3. Signal Timing Specification

**Table 6 Timing Table**

	ITEM	SYMBOL	MIN.	TYP.	MAX.	UNIT	NOTE
DCLK	Frequency	fCLK		38	40	MHz	
	Width-Low	t <sub>WCL</sub>	8	-	-	ns	
	Width-High	t <sub>WCH</sub>	5	-	-		
	Rise Time	t <sub>rCLK</sub>	-	-	25		
	Fall Time	t <sub>fCLK</sub>	-	-	25		
	Duty	D	0.45	0.5	0.55		
Hsync	Set up Time	t <sub>SH</sub>	3	-	-	ns	For DCLK
	Hold Time	t <sub>HH</sub>	8	-	-		
	Period	t <sub>HP</sub>	990	1024	1200	t <sub>CLK</sub>	
	Width-Active	t <sub>WH</sub>	12	-	120		
	Rise/Fall Time	t <sub>Hr</sub> , t <sub>Hf</sub>	-	-	30	ns	
Vsync	Set up Time	t <sub>SV</sub>	0	-	-	t <sub>CLK</sub>	For Hsync
	Hold Time	t <sub>HV</sub>	2	-	-		
	Period	t <sub>VP</sub>	604	625	730	t <sub>HP</sub>	
	Width-Active	t <sub>WV</sub>	1	-	24		
	Rise/Fall Time	t <sub>Vr</sub> , t <sub>Vf</sub>	-	-	50	ns	
DTMG	Set up Time	t <sub>SI</sub>	6	-	-	ns	For DCLK
	Hold Time	t <sub>HI</sub>	1	-	-		
	Rise/Fall Time	t <sub>Ir</sub> , t <sub>If</sub>	-	-	30	ns	
	Horizontal Back Porch	t <sub>HBP</sub>	20	-	-	t <sub>CLK</sub>	
	Horizontal Front Porch	t <sub>HFP</sub>	16				
	Vertical Back Porch	t <sub>VBP</sub>	0			t <sub>HP</sub>	
	Vertical Front Porch	t <sub>VFP</sub>	3				
DATA	Set up Time	t <sub>SD</sub>	6	-	-	ns	For DCLK
	Hold Time	t <sub>HD</sub>	3	-	-		
	Rise/Fall Time	t <sub>Dr</sub> , t <sub>Df</sub>	-	-	25	ns	



3-4. Signal Timing Wave form

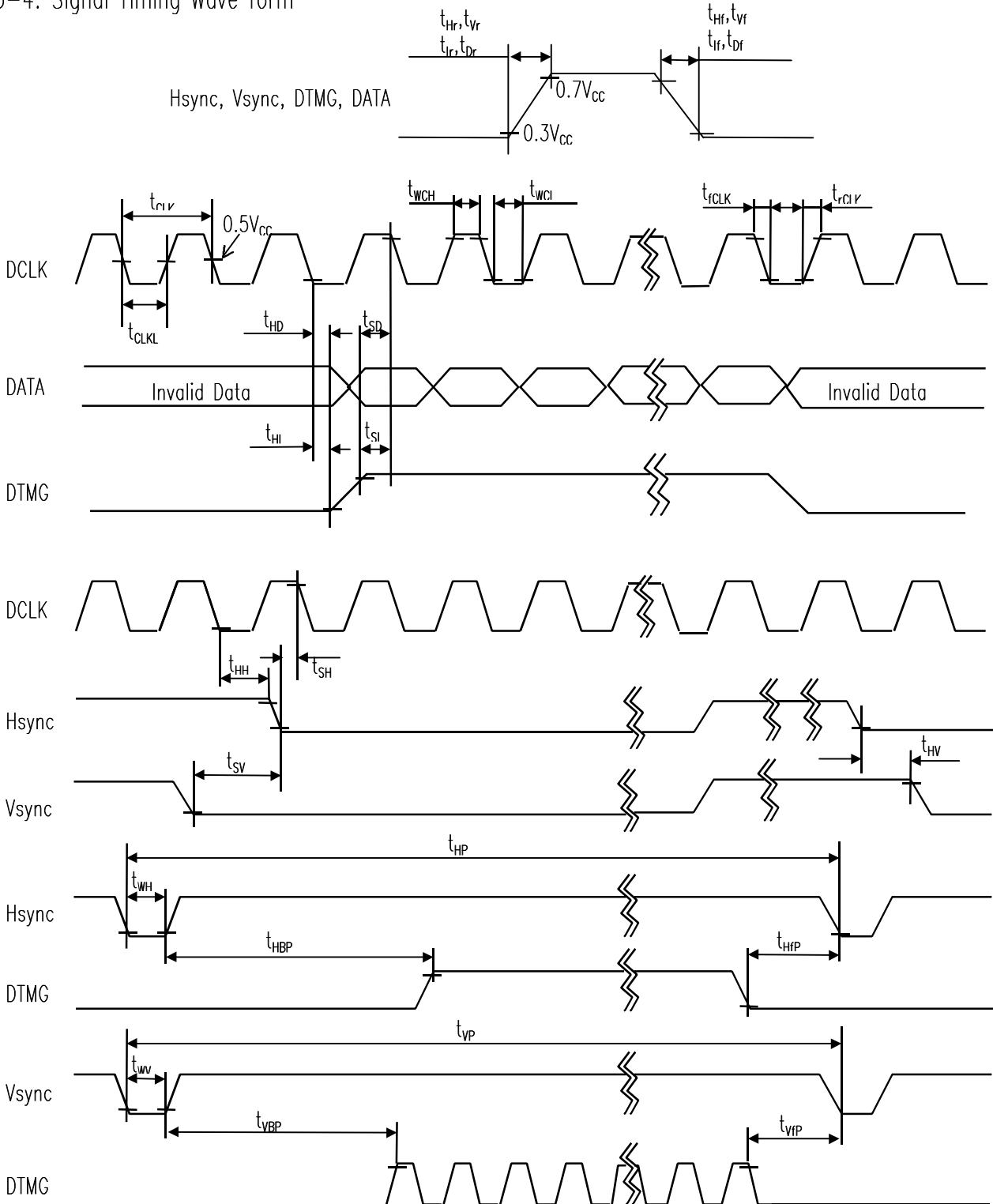

### 3-5. Color Input Data Reference

The brightness of each primary color(red, green and blue) is based on the 6-bit gray scale data input for the color; the higher the binary input, the brighter the color. The table below provides a reference for color versus data input.

**Table 7 COLOR DATA REFERENCE**

Color		Input Color Data																	
		Red						Green						Blue					
		MSB		LSB				MSB		LSB				MSB		LSB			
		R5	R4	R3	R2	R1	R0	G5	G4	G3	G2	G1	G0	B5	B4	B3	B2	B1	B0
Basic Colors	Black	0	0	0	0	0	0	0	0	0	0	0	0	0	0	0	0	0	0
	Red(63)	1	1	1	1	1	1	0	0	0	0	0	0	0	0	0	0	0	0
	Green(63)	0	0	0	0	0	0	1	1	1	1	1	1	0	0	0	0	0	0
	Blue(63)	0	0	0	0	0	0	0	0	0	0	0	0	1	1	1	1	1	1
	Cyan	0	0	0	0	0	0	1	1	1	1	1	1	1	1	1	1	1	1
	Magenta	1	1	1	1	1	1	0	0	0	0	0	0	1	1	1	1	1	1
	Yellow	1	1	1	1	1	1	1	1	1	1	1	1	0	0	0	0	0	0
	White	1	1	1	1	1	1	1	1	1	1	1	1	1	1	1	1	1	1
Red	Red(00) Dark	0	0	0	0	0	0	0	0	0	0	0	0	0	0	0	0	0	0
	Red(01)	0	0	0	0	0	1	0	0	0	0	0	0	0	0	0	0	0	0
	Red(02)	0	0	0	0	1	0	0	0	0	0	0	0	0	0	0	0	0	0
	:	:	:	:	:	:	:	:	:	:	:	:	:	:	:	:	:	:	:
	Red(61)	1	1	1	1	0	1	0	0	0	0	0	0	0	0	0	0	0	0
	Red(62)	1	1	1	1	1	0	0	0	0	0	0	0	0	0	0	0	0	0
	Red(63) Bright	1	1	1	1	1	1	0	0	0	0	0	0	0	0	0	0	0	0
Green	Green(00)Dark	0	0	0	0	0	0	0	0	0	0	0	0	0	0	0	0	0	0
	Green(01)	0	0	0	0	0	0	0	0	0	0	0	1	0	0	0	0	0	0
	Green(02)	0	0	0	0	0	0	0	0	0	0	1	0	0	0	0	0	0	0
	:	:	:	:	:	:	:	:	:	:	:	:	:	:	:	:	:	:	:
	Green(61)	0	0	0	0	0	0	1	1	1	1	0	1	0	0	0	0	0	0
	Green(62)	0	0	0	0	0	0	1	1	1	1	1	0	0	0	0	0	0	0
	Green(63)Bright	0	0	0	0	0	0	1	1	1	1	1	1	0	0	0	0	0	0
Blue	Blue(00) Dark	0	0	0	0	0	0	0	0	0	0	0	0	0	0	0	0	0	0
	Blue(01)	0	0	0	0	0	0	0	0	0	0	0	0	0	0	0	0	0	1
	Blue(02)	0	0	0	0	0	0	0	0	0	0	0	0	0	0	0	0	1	0
	:	:	:	:	:	:	:	:	:	:	:	:	:	:	:	:	:	:	:
	Blue(61)	0	0	0	0	0	0	0	0	0	0	0	0	1	1	1	1	0	1
	Blue(62)	0	0	0	0	0	0	0	0	0	0	0	0	1	1	1	1	1	0
	Blue(63) Bright	0	0	0	0	0	0	0	0	0	0	0	0	1	1	1	1	1	1



3-6. Power Sequences

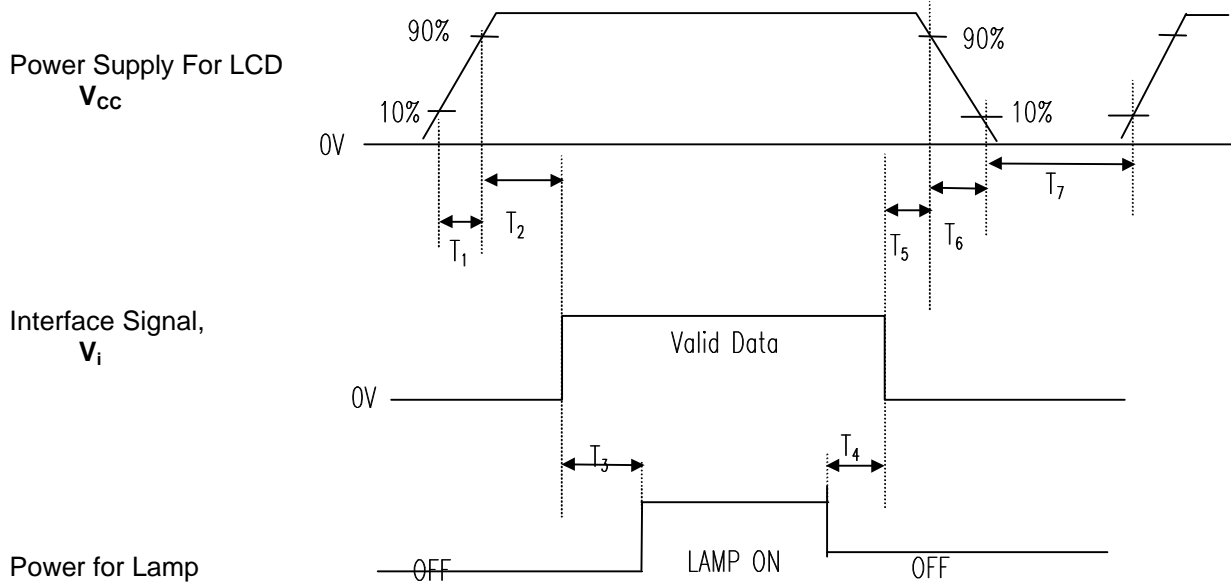

Parameter	Values			Units
	Min.	Typ.	Max.	
$T_1$	-	-	10	ms
$T_2$	0.01	-	20	ms
$T_3$	200	-	-	ms
$T_4$	200	-	-	ms
$T_5$	0.01	-	20	ms
$T_6$	0.01	-	-	ms
$T_7$	3	-	-	s

- Notes:
1. Please avoid floating state of interface signal at invalid period.
  2. When the interface signal is invalid, be sure to pull down the power supply for LCD  $V_{CC}$  to 0V.
  3. Lamp power must be turn on after power supply for LCD and interface signal are valid.



### 3-7. Vcc Dip Conditions

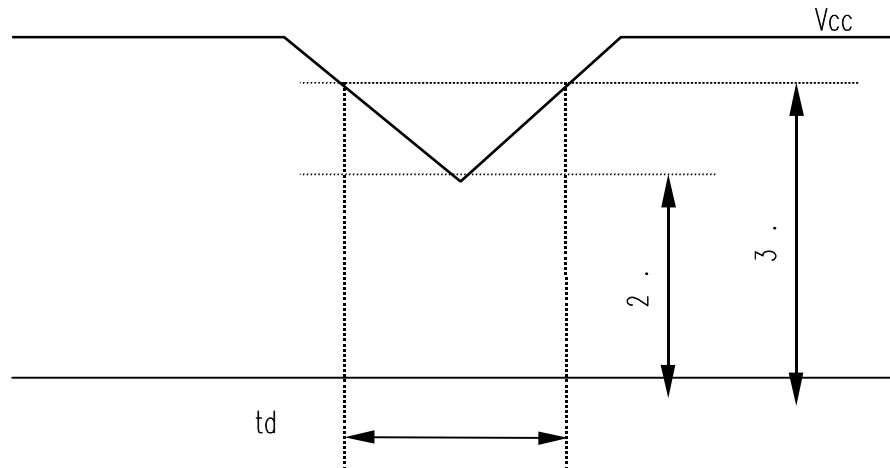

- 1) 2.5V Vcc 3.0V  
td 20

- 2) Vcc 2.5V

Vcc-dip conditions should also follow the Power Up/Down conditions for supply voltage

Notes :This phenomenon is caused by row driver IC initialization after power on (1 vertical period) .

#### 4. Optical Specifications

Optical characteristics are determined after the unit has been 'ON' and stable for approximately 30 minutes in a dark environment at 25°C. The values specified are at an approximate distance 50cm from the LCD surface at a viewing angle of  $\Phi$  and  $\theta$  equal to  $0^\circ$ .

Appendix A -1 presents additional information concerning the measurement equipment and method..

**Table 8 OPTICAL CHARACTERISTICS**

Parameter	Symbol	Values			Units	Notes
		Min.	Typ.	Max.		
Contrast Ratio	CR	-	200	-		1
Surface Luminance, white	L <sub>WH</sub>	255	300	-	cd/m <sup>2</sup>	2
Luminance Variation	WHITE	-	1.25	1.45		3
Response Time	T <sub>r</sub>				msec	4
Rise Time	T <sub>rR</sub>	-	20	50		
Decay Time	T <sub>rD</sub>	-	35	50		
CIE Color Coordinates						
Red	X <sub>R</sub>	tbd	0.598	tbd		
	y <sub>R</sub>	tbd	0.344	tbd		
Green	X <sub>G</sub>	tbd	0.312	tbd		
	y <sub>G</sub>	tbd	0.538	tbd		
Blue	X <sub>B</sub>	tbd	0.153	tbd		
	y <sub>B</sub>	tbd	0.136	tbd		
White	X <sub>W</sub>	tbd	0.320	tbd		
	y <sub>W</sub>	tbd	0.340	tbd		
Viewing Angle						
x axis, right ( =0°)	x	+55	-	-	degree	5
x axis, left( =180°)	x	-55	-	-		
y axis, up( =90°)	y	+40	-	-		
y axis, down ( =270°)	y	-45	-	-		
Gray Scale		-	-	-		6

Notes 1. Contrast Ratio (CR) is defined mathematically as :

$$\text{Contrast Ratio} = \frac{\text{Surface Luminance with all white pixels}}{\text{Surface Luminance with all black pixels}}$$

- Surface luminance is the center point across the LCD surface 50cm from the surface with all pixels displaying white. For more information see Appendix A - 2.
- The variation in surface Luminance, **WHITE** is determined by measuring L<sub>ON</sub> at each test position 1 through 5, and then dividing the maximum L<sub>ON</sub> of 5 points luminance by minimum L<sub>ON</sub> of 5 points luminance. For more information see Appendix A - 2.  
**WHITE** Maximum (L<sub>ON1</sub>, L<sub>ON2</sub>, ..., L<sub>ON5</sub>) Minimum (L<sub>ON1</sub>, L<sub>ON2</sub>, ..., L<sub>ON5</sub>)
- Response time is the time required for the display to transition from white to black (Rise Time, T<sub>rR</sub>) and from black to white (Decay Time, T<sub>rD</sub>). For additional information see Appendix A - 3.
- Viewing angle is the angle at which the contrast ratio is greater than 10. The angles are determined for the horizontal or x axis and the vertical or y axis with respect to the z axis which is normal to the LCD surface. For more information see Appendix A - 4

Notes 6.Gray scale specification.

Gray Level	Luminance (%) (typ)
L0	0.27
L7	0.65
L15	2.02
L23	6.91
L31	18.82
L39	37.41
L47	64.02
L55	90.63
L63	100





Product Specification

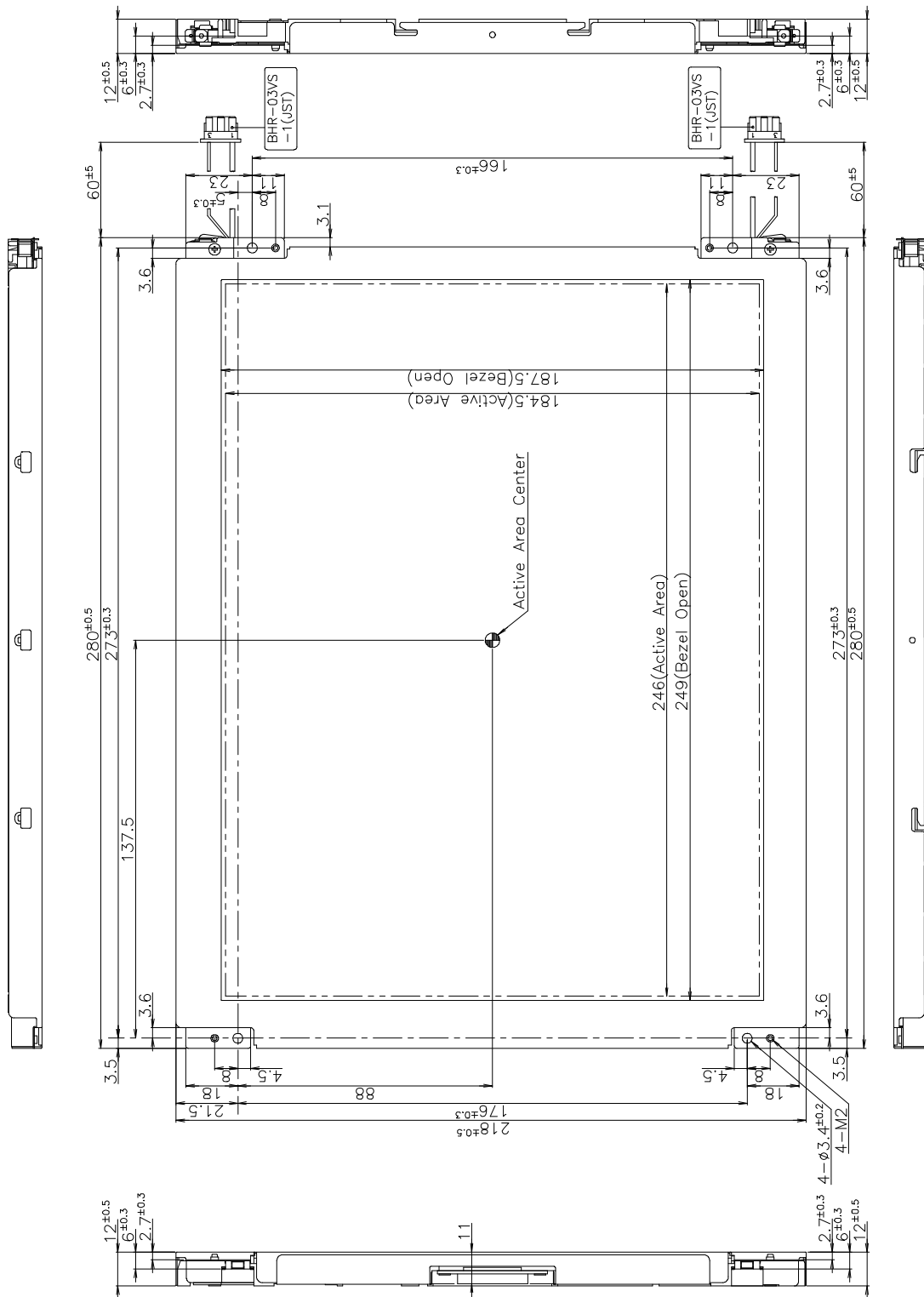

< REAR VIEW >

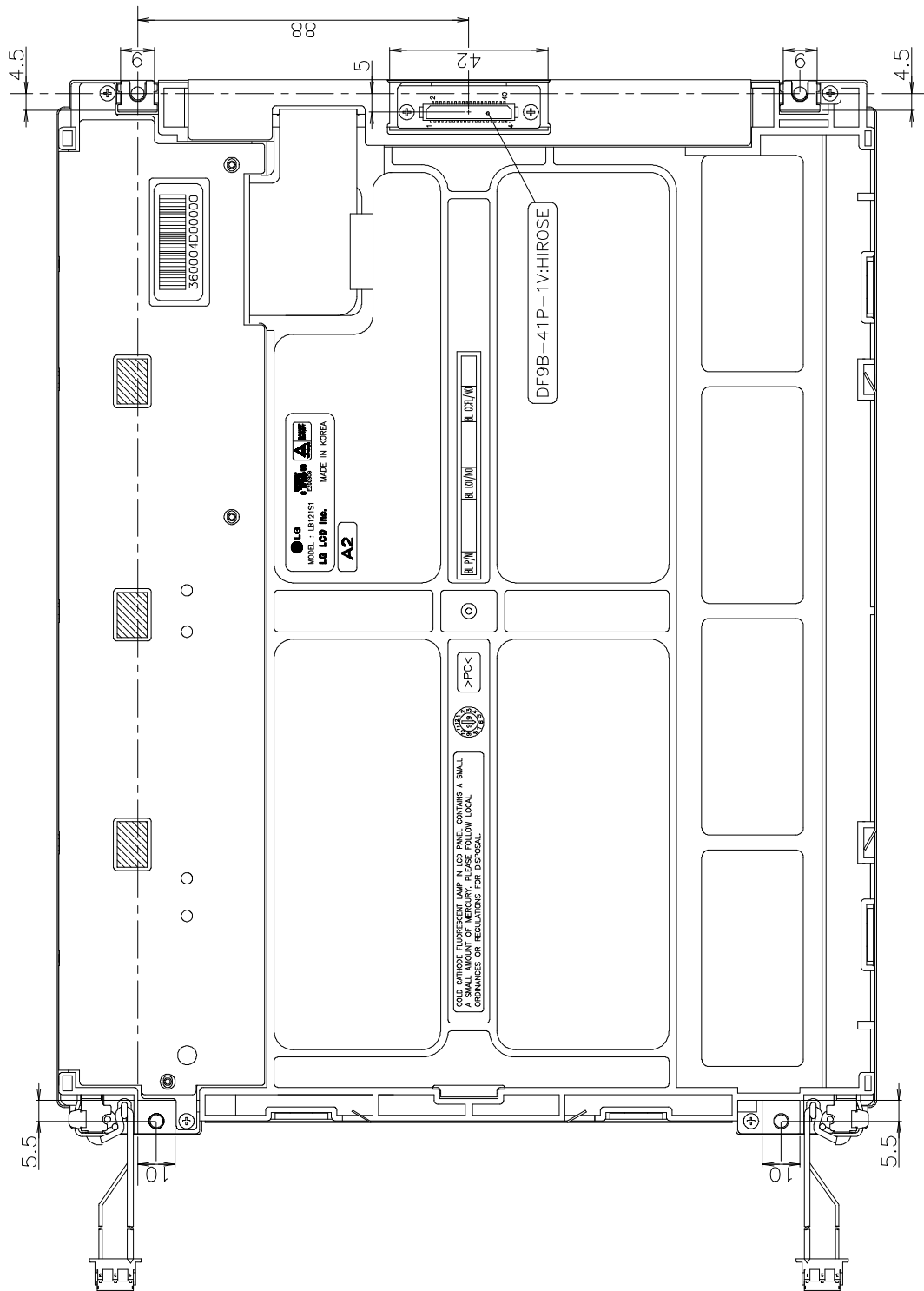



**6. Reliability**

- Environment test condition

No.	Test ITEM	Conditions
1	High temperature storage test	Ta = 60 240h
2	Low temperature storage test	Ta = -20 240h
3	High temperature operation test	Ta = 50 50%RH 240h
4	Low temperature operation test	Ta = 0 240h
5	Vibration test (non-operating)	Random : 10~500Hz, 0.0046g /Hz, 1Grms, 3axis, 1hour/axis
6	Shock test (non-operating)	half sine wave : 120G, 2ms, one shock of each six faces. (i.e. run 120G 2ms for all six faces.)
7	Altitude storage/shipment	0 - 40,000 feet (12192m)

{Result Evaluation Criteria}

There should be no change which might affect the practical display function when the display quality test is conducted under normal operating condition.

- ON/OFF Cycle

: The display module will be capable of being operated over 24,000 ON/OFF cycles (Lamp power & Vcc ON/OFF)

- Mean Time Between Failure

: The LCD Panel and interface board assembly (excluding the CCFTs) shall have a mean time between failures of 30,000 hours with a confidence level 90%.

**7. International Standards**

## 7-1. Safety

- a) UL 1950 Third Edition, Underwriters Laboratories, Inc. Jan. 28, 1995.  
Standard for Safety of Information Technology Equipment Including Electrical Business Equipment.
- b) CAN/CSA C22.2 No. 950-95 Third Edition, Canadian Standards Association, Jan. 28, 1995.  
Standard for Safety of Information Technology Equipment Including Electrical Business Equipment.
- c) EN 60950 : 1992 + A1 : 1993 + A2 : 1993 + A3 : 1995 + A4 : 1997 + A11 : 1997  
IEC 950 : 1991 + A1 : 1992 + A2 : 1993 + A3 : 1995 + A4 : 1996  
European Committee for Electrotechnical Standardization (CENELEC)  
EUROPEAN STANDARD for Safety of Information Technology Equipment Including Electrical Business Equipment.

## 7-2. EMC

- a) ANSI C63.4 „Methods of Measurement of Radio-Noise Emissions from Low-Voltage Electrical and Electronic Equipment in the Range of 9kHz to 40GHz.“ American National Standards Institute(ANSI),1992.
- b) C.I.S.P.R „Limits and Methods of Measurement of Radio Interference Characteristics of Information Technology Equipment.“ International Special Committee on Radio Interference
- c) EN 55022 „Limits and Methods of Measurement of Radio Interference Characteristics of Information Technology Equipment.“ European Committee for Electrotechnical Standardization (CENELEC),1988



### 8. Packaging

#### 8-1. Designation of Lot Mark

a) Lot Mark



A, B, C : INCH CODE  
 D : YEAR  
 E : MONTH  
 F, G : PANEL FACTORY  
 H : MODULE LINE  
 I, J, K, L, M : SERIAL NO.

Note : 1. YEAR(D)

YEAR	89	90	91	92	93	94	95	96	97	98	99
Mark	9	0	1	2	3	4	5	6	7	8	9

2. MONTH(E)

MONTH	Jan.	Feb.	Mar.	Apr.	May	Jun.	Jun.	Aug.	Sep.	Oct.	Nov.	Dec.
Mark	1	2	3	4	5	6	7	8	9	0	N	D

3. MODULE LINE(H)

LINE	1	2	3	4	5	6	7	8	9	10	11	12	13
Mark	1	2	3	4	5	6	7	8	9	A	B	C	D

b) Location of Lot Mark

Serial NO. Is printed on the label. The label is attached to the backside of the LCD module.  
 This is subject to change without prior notice.

#### 8-2. Packing Form

- a) Package quantity in one box : 10 pcs
- b) Box Size : 302mm 365mm 340mm

## **9. PRECAUTIONS**

Please pay attention to the followings when you use this TFT/LCD module.

### **9.1 MOUNTING PRECAUTIONS**

- (1) You must mount a module using holes arranged in four corners.
- (2) You should consider the mounting structure so that uneven force (ex. twisted stress) is not applied to the module.  
And the case on which a module is mounted should have sufficient strength so that external force is not transmitted directly to the module.
- (3) Please attach the surface with a transparent protective plate in order to protect the polarizer LC cell.  
Transparent protective plate should have sufficient strength in order to resist external force.
- (4) You should adopt radiation structure to satisfy the temperature specification.
- (5) Acetic acid type and chlorine type materials for the cover case are not desirable because the former generates corrosive gas of attacking the polarizer at high temperature and the latter causes circuit break by electro-chemical reaction.
- (6) Do not touch, push or rub the exposed polarizers with glass, tweezers or anything harder than HB pencil lead. And Please do not rub with dust clothes with chemical treatment.  
Do not touch the surface of polarizer for bare hand or greasy cloth. (Some cosmetics are detrimental to the polarizer.)
- (7) When the surface becomes dusty, please wipe gently with absorbent cotton or other soft materials like chamois soaked with petroleum benzene. Normal-hexane is recommended for cleaning the adhesives used to attach front / rear polarizers. Do not use acetone, toluen and alcohol because they cause chemical damage to the polarizer.
- (8) Wipe off saliva or water drops as soon as possible. Their long time contact with polarizer causes deformations and color fading.
- (9) Do not open the case because inside circuits do not have sufficient strength.

### **9.2 OPERATING PRECAUTIONS**

- (1) The spike noise causes the mis-operation of circuits. It should be lower than following voltage :  $V = \pm 200\text{mV}$  (Over and under shoot voltage).
- (2) Response time depends on the temperature. (In lower temperature, it becomes longer.)
- (3) Brightness depends on the temperature. (In lower temperature, it becomes lower.)  
And in lower temperature, response time (required time that brightness is stable after turned on ) becomes longer.
- (4) Be careful for condensation at sudden temperature change. Condensation makes damage to polarizer or electrical contacted parts. And after fading condensation, smear or spot will occur.
- (5) When fixed patterns are displayed for a long time, remnant image is likely to occur.
- (6) A module has high frequency circuit. If you need to shield the electromagnetic noise, please do in yours.
- (7) When a Back-light unit is operating, it sounds. If you need to shield the noise, please do in yours.

### **9.3 ELECTROSTATIC DISCHARGE CONTROL**

Since a module is composed of electronic circuits, it is not strong to electrostatic discharge. Make certain that treatment persons are connected to ground through wrist band etc . . And don't touch I/F pin directly.

#### **9.4 PRECAUTION FOR STRONG LIGHT EXPOSURE**

Strong light exposure causes degradation of polarizer and color filter.

#### **9.5 STORAGE**

When storing modules as spares for a long time. The following precautions are necessary.

- (1) Store them in a dark place. Do not expose the module to sunlight or fluorescent light.  
Keep the temperature between 5 and 35 at normal humidity.
- (2) The polarizer surface should not come in contact with any other object.  
It is recommended that they be stored in the container in which they were shipped.

#### **9.6 HANDLING PRECAUTIONS FOR PROTECTION FILM**

- (1) When the protection film is peeled off, static electricity is generated between the film and polarizer.  
This should be peeled off slowly and carefully by people who are electrically grounded and with well ion- blown equipment or in such a condition, etc..
- (2) The protection film is attached to the polarizer with a small amount of glue. If some stress is applied to rub the protection film against the polarizer during the time you peel off the film, the glue is apt to remain on the polarizer.  
Please carefully peel off the protection film without rubbing it against the polarizer.
- (3) When the module with protection film attached is stored for a long time, sometimes there remains a very small amount of glue still on the polarizer after the protection film is peeled off.
- (4) You can remove the glue easily. When the glue remains on the polarizer surface or its vestige is recognized, please wipe them off with absorbent cotton waste or other soft material like chamois soaked with normal- hexane.



### A-1 Optical Characteristic Measurement Equipment and Method

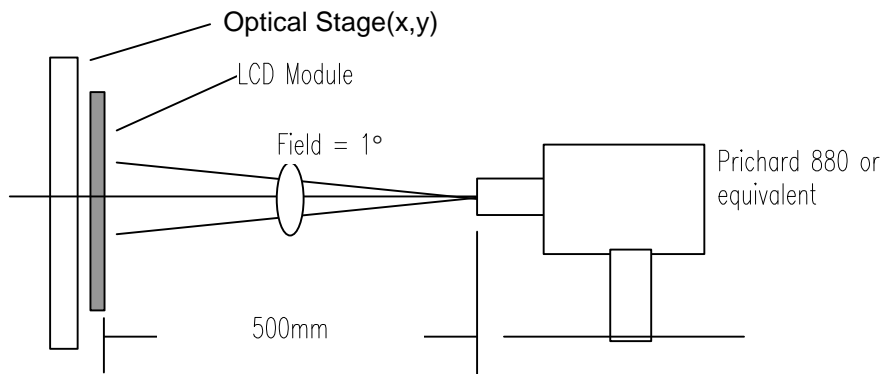

### A-2 Luminance

<measuring point for luminance variation>

<measuring point for surface luminance >

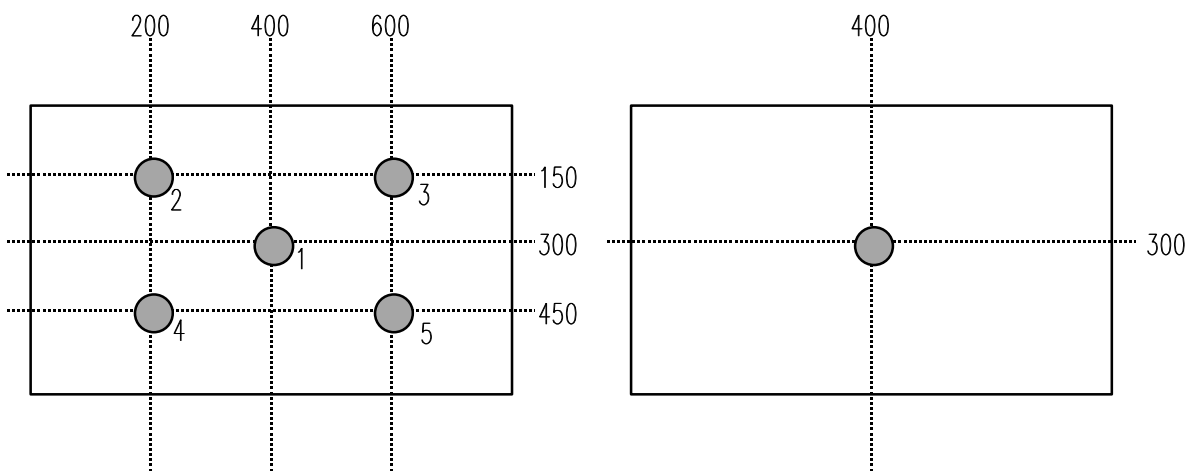

### A-3 Response Time

The response time is defined as the following figure and shall be measured by switching the input signal for „black“ and „white“.

