

Product Specification

SPECIFICATION FOR APPROVAL

(◆) Preliminary Specification

() Final Specification

| | |
|-------|--------------------|
| Title | 12.1" SVGA TFT LCD |
|-------|--------------------|

| | |
|-------|--|
| BUYER | |
| MODEL | |

| | |
|----------|--------------------------|
| SUPPLIER | LG.Philips LCD Co., Ltd. |
| *MODEL | LC121S1 |
| SUFFIX | A1MT |

* When you obtain standard approval ,
please use the above model name without suffix.

| SIGNATURE | DATE |
|--|------|
| | |
| | |
| Please return 1 copy for your confirmation with your signature and comments. | |

| SIGNATURE | DATE |
|---|------|
| APPROVED BY | |
| I.J.Chung /VicePresident | |
| REVIEWED BY | |
| I.H.Ahn / G.Manager | |
| PREPARED BY | |
| H.J.KIM / Manager | |
| Product Engineering Dept. LG.Philips LCD Co., Ltd. | |

Product Specification

CONTENTS

| NO. | ITEM | Page |
|-----|------------------------------|------|
| - | COVER | 1 |
| - | CONTENTS | 2 |
| - | RECORD OF REVISIONS | 3 |
| 1 | GENERAL DESCRIPTION | 4 |
| 2 | ABSOLUTE MAXIMUM RATINGS | 5 |
| 3 | ELECTRICAL SPECIFICATIONS | 6 |
| 3-1 | ELECTRICAL CHARACTERISTICS | 6 |
| 3-2 | INTERFACE CONNECTIONS | 7 |
| 3-3 | SIGNAL TIMING SPECIFICATIONS | 9 |
| 3-4 | SIGNAL TIMING WAVEFORMS | 10 |
| 3-5 | COLOR INPUT DATA REFERENCE | 11 |
| 3-6 | POWER SEQUENCE | 12 |
| 4 | OPTICAL SPECIFICATIONS | 14 |
| 5 | MECHANICAL CHARACTERISTICS | 17 |
| 6 | RELIABILITY | 21 |
| 7 | INTERNATIONAL STANDARDS | 22 |
| 7-1 | SAFETY | 22 |
| 7-2 | EMC | 22 |
| 8 | PACKING | 23 |
| 8-1 | DESIGNATION OF LOT MARK | 23 |
| 8-2 | PACKING FORM | 23 |
| 9 | PRECAUTIONS | 24 |

Product Specification**RECORDS OF REVISIONS**

| Version No | Date | Page | DESCRIPTION |
|-------------------|---------------|-------------|--------------------|
| 0.0 | Nov. 13, 2000 | - | First Draft |

Product Specification

1. General Description

The LC121S1 is a Color Active Matrix Liquid Crystal Display with an integral Cold Cathode Fluorescent Lamp(CCFL) backlight system. The matrix employs a-Si Thin Film Transistor as the active element. It is a transflective type⁽¹⁾ display operating in the normally white mode. This TFT-LCD has a 12.1 inches diagonally measured active display area with SVGA resolution(600 vertical by 800 horizontal pixel array). Each pixel is divided into Red, Green and Blue sub-pixels or dots which are arranged in vertical stripes. Gray scale or the brightness of the sub-pixel color is determined with a 6-bit gray scale signal for each dot, thus, presenting a palette of 262,144 colors.

The LC121S1 has been designed to apply the interface method that enables low power. Flat Link must be used as a LVDS(Low Voltage Differential Signaling) chip.

The LC121S1 is intended to support applications where low power are critical factors and graphic displays are important. In combination with the vertical arrangement of the sub-pixels, the LC121S1 characteristics provide an excellent flat panel display for office automation products such as Mobile PC.

(Definition.1 : Transflective type is transmissive mode added to reflective mode..)

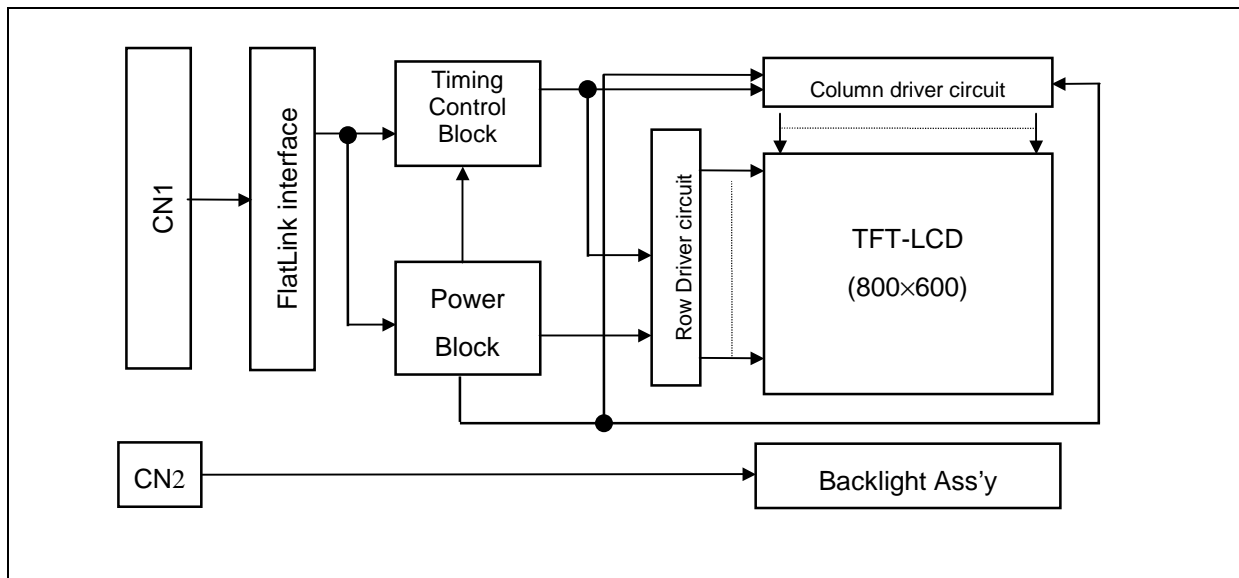

General Features

| | |
|------------------------|--|
| Active screen size | 12.1 inches(30.7cm) diagonal |
| Outline dimensions | 261(H) × 199(V) × 6.5(D) mm (Typ.) |
| Pixel pitch | 0.1025 mm × RGB x 0.3075 mm |
| Pixel format | 800 horiz. by 600 vert. pixels RGB stripe arrangement |
| Color depth | 6-bit, 262,144 colors |
| Luminance,White | 90 cd/m ² (Typ.) |
| Power Consumption | Total 5Watt(Typ.) (1Watt at circuit logic only) |
| Weight | 420g (Typ.) |
| Display operating mode | Transflective mode, Normally White |
| Surface treatments | Hard coating (3H), |

Product Specification

2. Absolute Maximum Ratings

The following are maximum values which, if exceeded, may cause faulty operation or damage to the unit.

Table 1 ABSOLUTE MAXIMUM RATINGS

| Parameter | symbol | Values | | Units | Notes |
|----------------------------|-----------------|--------|------|-------|-------------|
| | | Min. | Max. | | |
| Power Input Voltage | V _{CC} | -0.3 | 4.0 | Vdc | at 25 ± 5°C |
| Operating Temperature | T _{OP} | 0 | 50 | °C | 1 |
| Storage Temperature | T _{ST} | -20 | 60 | °C | 1 |
| Operating Ambient Humidity | H _{OP} | 10 | 90 | %RH | 1 |
| Storage Humidity | H _{ST} | 10 | 90 | %RH | 1 |

Note: 1. Temperature and relative humidity range are shown in the figure below.
Wet bulb temperature should be 39°C Max, and no condensation of water.

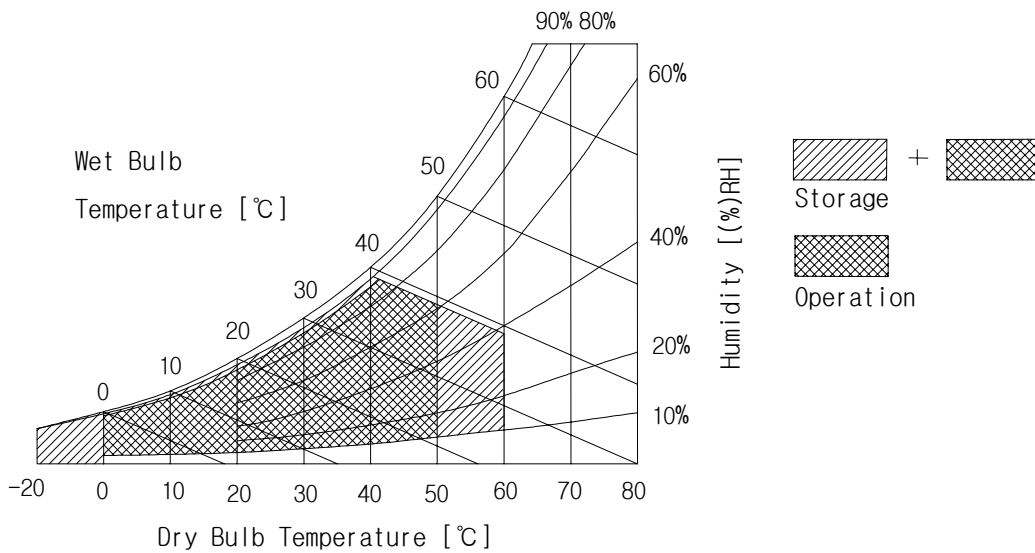

Product Specification

3. Electrical Specifications

3-1. Electrical Characteristics

The LC121S1 requires two power inputs. One is employed to power the LCD electronics and to drive the TFT array and liquid crystal. The second input which powers the CCFL, is typically generated by an inverter. The inverter is an external unit to the LCD.

Table 2 ELECTRICAL CHARACTERISTICS:

| Parameter | Symbol | Values | | | Units | Notes |
|------------------------------|------------|--------|-------|-------|-----------|-------|
| | | Min. | Typ. | Max. | | |
| MODULE: | | | | | | |
| Power Supply Input Voltage | V_{CC} | 3.0 | 3.3 | 3.6 | Vdc | |
| Power Supply Input Current | I_{CC} | - | 0.295 | 0.395 | A | 1 |
| Differential Impedance | Z_m | 90 | 100 | 110 | ohm | 2 |
| Power Consumption | P_c | - | 1.0 | 1.3 | Watts | 1 |
| Rush current | I_{RUSH} | - | 1.6 | 1.8 | A | 3 |
| LAMP | | | | | | |
| Operating Voltage | V_{BL} | 540 | 600 | 660 | V_{RMS} | 4 |
| Operating Current | I_{BL} | 3.0 | - | 6.0 | mA | |
| Established Starting Voltage | | | | | | 5 |
| at 25 °C | | - | - | 770 | V_{RMS} | |
| at 0 °C | | - | - | 750 | V_{RMS} | |
| Operating Frequency | f_{BL} | 40 | 55 | (80) | kHZ | |
| Discharge Stabilization Time | T_s | - | - | 3 | Minutes | 6 |
| Power Consumption | P_{BL} | - | 4.0 | 4.32 | Watts | 7 |
| Life Time | | 10,000 | - | - | Hrs | 8 |

- Notes: 1. The specified current and power consumption are under the $V_{cc} = 3.3V$, $25^{\circ}C$, $f_v = 60Hz$ condition whereas MOSAIC pattern is displayed and f_v is the frame frequency.
2. This impedance value is needed to proper display and measured form LVDS Tx to the mating connector.
3. The duration of rush current is about 20ms.
4. The variance of the voltage is $\pm 10\%$.
5. The transformer output voltage in the inverter must be high considering to the loss of the ballast capacitor in the inverter.
6. Let's define the brightness of the lamp after being lighted for 5 minutes as 100%.
 T_s is the time required for the brightness of the center of the lamp to be not less than 95%.
7. The lamp power consumption shown above does not include loss of external inverter.
8. The life time is determined as the time at which brightness of lamp is 50% compare to that of initial value at the typical lamp current.

Product Specification

3-2. Interface Connections

Interface chip must be used FlatLink, part No. THC63LVDM63A(Transmitter) , THC63LVDF64A(Receiver) made by Thine Microsystems,Inc. Pin to Pin compatible with TI LVDS.

This LCD employs two interface connections, a 20 pin connector is used for the module electronics and the other connector is used for the integral backlight system.

The electronics interface connector is a model DF19K-20P-1H manufactured by HIROSE. The pin configuration for the connector is shown in the table below.

Table 3 MODULE CONNECTOR PIN CONFIGURATION (LVDS)

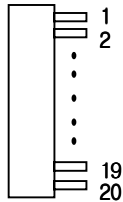
| Pin | Symbol | Description | Notes |
|-----|--------|---------------------|--|
| 1 | Vcc | Power (3.3V) | 1. Interface chips 1.1 LCD : THC63LVDF64A 48TSSOP 1.2 System : THC63LVDM63A 48TSSOP * Pin to Pin compatible with TI LVDS 2. Connector 2.1 LCD : DF19K-20P-1H (HIROSE) 2.2 Mating : Wire Type : DF19G-20S-1C (HIROSE) FPC Type : DF19-20S-1F (HIROSE) 2.3 Connector pin arrangement  |
| 2 | Vcc | Power (3.3V) | |
| 3 | GND | Ground | |
| 4 | GND | Ground | |
| 5 | NC | No Connection | |
| 6 | NC | No Connection | |
| 7 | GND | Ground | |
| 8 | A0M | Differential Signal | |
| 9 | A0P | Differential Signal | |
| 10 | GND | Ground | |
| 11 | A1M | Differential Signal | |
| 12 | A1P | Differential Signal | |
| 13 | GND | Ground | |
| 14 | A2M | Differential Signal | |
| 15 | A2P | Differential Signal | |
| 16 | GND | Ground | |
| 17 | CLKM | Differential Signal | |
| 18 | CLKP | Differential Signal | |
| 19 | GND | Ground | |
| 20 | NC | No Connection | |

The backlight interface connector is a model BHSR-02VS-1, manufactured by JST. The mating connector part number is SM02B-BHSS-1 or equivalent. The pin configuration for the connector is shown in the table below.

Table 4 BACKLIGHT CONNECTOR PIN CONFIGURATION

| Pin | Symbol | Description | Notes |
|-----|--------|---|-------|
| 1 | HV | Power supply for lamp (High voltage side) | 1 |
| 2 | LV | Power supply for lamp (Low voltage side) | 1 |

Notes: 1. The high voltage side terminal is colored pink. The low voltage side terminal is white.

Product Specification

Table 5 REQUIRED SIGNAL ASSIGNMENT FOR FlatLink Transmitter

| Pin # | Pin Name | Require Signals | Pin # | Pin Name | Require Signals |
|-------|----------|-----------------|-------|--------------------------|--------------------------|
| 1 | D4 | R4 | 48 | D3 | R3 |
| 2 | Vcc | Vcc | 47 | D2 | R2 |
| 3 | D5 | R5 | 46 | GND | GND |
| 4 | D6 | G0 | 45 | D1 | R1 |
| 5 | GND | GND | 44 | D0 | R0 |
| 6 | D7 | G1 | 43 | NC | NC |
| 7 | D8 | G2 | 42 | LVDS GND | LVDS GND |
| 8 | Vcc | Vcc | 41 | Y0M | A0M |
| 9 | D9 | G3 | 40 | Y0P | A0P |
| 10 | D10 | G4 | 39 | Y1M | A1M |
| 11 | GND | GND | 38 | Y1P | A1P |
| 12 | D11 | G5 | 37 | LVDS Vcc | LVDS Vcc |
| 13 | D12 | B0 | 36 | LVDS GND | LVDS GND |
| 14 | NC | NC | 35 | Y2M | A2M |
| 15 | D13 | B1 | 34 | Y2P | A2P |
| 16 | D14 | B2 | 33 | CLKOUTM | CLKM |
| 17 | GND | GND | 32 | CLKOUTP | CLKP |
| 18 | D15 | B3 | 31 | LVDS GND | LVDS GND |
| 19 | D16 | B4 | 30 | PLL GND | PLL GND |
| 20 | D17 | B5 | 29 | PLL Vcc | PLL Vcc |
| 21 | Vcc | Vcc | 28 | PLL GND | PLL GND |
| 22 | D18 | HSYNC | 27 | $\overline{\text{SHDN}}$ | $\overline{\text{SHDN}}$ |
| 23 | D19 | VSYNC | 26 | CLKIN | Dclk |
| 24 | GND | GND | 25 | D20 | DE(Data Enable) |

Notes : Refer to LVDS Transmitter Data Sheet for detail descriptions.

Product Specification

3-3. Signal Timing Specifications

This is the signal timing required at the input of the LVDS Transmitter. All of the interface signal timing should be satisfied with the following specifications for its proper operation.

Table 6 Timing Table

| ITEM | | SYMBOL | MIN. | TYP. | MAX. | UNIT | NOTES |
|--------------------------|------------------------|-----------|------|------|-------------------|-----------|------------------------------|
| Dclk | Period | t_{CLK} | 25 | 26 | 27 | ns | 38.5MHz |
| Hsync | Period | t_{HP} | 990 | 1024 | 1100 | t_{CLK} | |
| | Width | t_{WH} | 12 | - | 120 | | |
| Vsync | Period | t_{VP} | 604 | 625 | 730 | t_{HP} | |
| | Frequency | f_V | 60 | 60 | 60 | Hz | |
| | Width | t_{WV} | 1 | - | 24 | t_{HP} | |
| DE (Data Enable) | Horizontal Valid | t_{HV} | 800 | 800 | 800 | t_{CLK} | |
| | Horizontal Back Porch | t_{HBP} | 30 | - | - | | |
| | Horizontal Front Porch | t_{HFP} | 30 | - | - | | |
| | Horizontal Blank | - | 19 | ~ | $t_{HP} - t_{HV}$ | | $t_{WH} + t_{HBP} + t_{HFP}$ |
| | Vertical Valid | t_{VV} | 600 | 600 | 600 | t_{HP} | |
| | Vertical Back Porch | t_{VBP} | 0 | - | - | | |
| | Vertical Front Porch | t_{VFP} | 3 | - | - | | |
| | Vertical Blank | - | 4 | ~ | $t_{VP} - t_{VV}$ | | $t_{WV} + t_{VBP} + t_{VFP}$ |

3-4. Signal Timing Waveforms

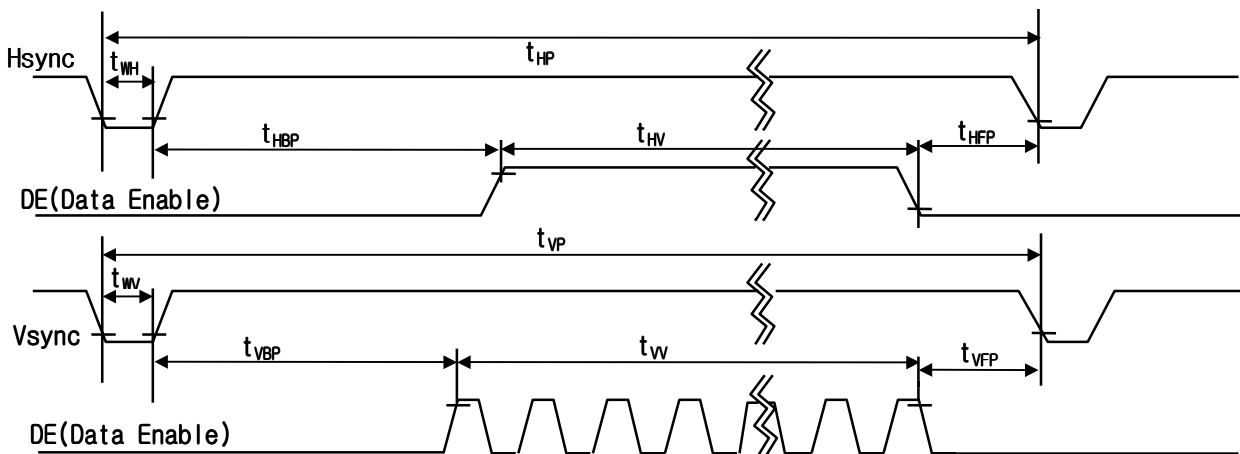
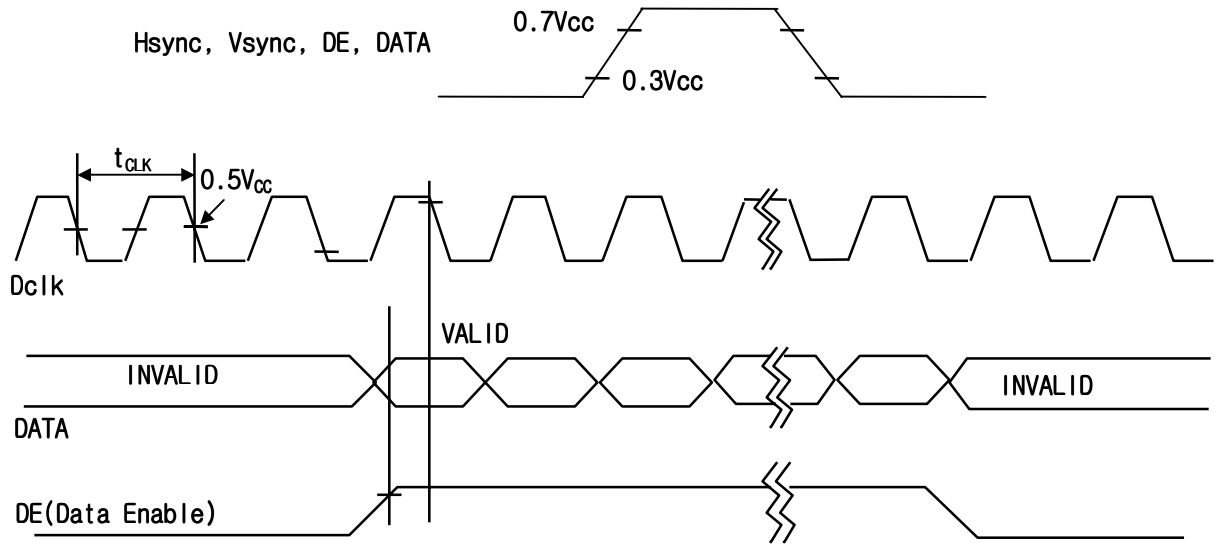

Product Specification

3-5. Color Input Data Reference

The brightness of each primary color (red, green and blue) is based on the 6-bit gray scale data input for the color; the higher the binary input, the brighter the color. The table below provides a reference for color versus data input.

Table 7 COLOR DATA REFERENCE

| Color | | Input Color Data | | | | | | | | | | | | | | | | | |
|--------------|-----------------|------------------|----|-----|----|----|----|-------|----|-----|----|----|----|------|----|-----|----|----|----|
| | | Red | | | | | | Green | | | | | | Blue | | | | | |
| | | MSB | | LSB | | | | MSB | | LSB | | | | MSB | | LSB | | | |
| | | R5 | R4 | R3 | R2 | R1 | R0 | G5 | G4 | G3 | G2 | G1 | G0 | B5 | B4 | B3 | B2 | B1 | B0 |
| Basic Colors | Black | 0 | 0 | 0 | 0 | 0 | 0 | 0 | 0 | 0 | 0 | 0 | 0 | 0 | 0 | 0 | 0 | 0 | 0 |
| | Red(63) | 1 | 1 | 1 | 1 | 1 | 1 | 0 | 0 | 0 | 0 | 0 | 0 | 0 | 0 | 0 | 0 | 0 | 0 |
| | Green(63) | 0 | 0 | 0 | 0 | 0 | 0 | 1 | 1 | 1 | 1 | 1 | 1 | 0 | 0 | 0 | 0 | 0 | 0 |
| | Blue(63) | 0 | 0 | 0 | 0 | 0 | 0 | 0 | 0 | 0 | 0 | 0 | 0 | 1 | 1 | 1 | 1 | 1 | 1 |
| | Cyan | 0 | 0 | 0 | 0 | 0 | 0 | 1 | 1 | 1 | 1 | 1 | 1 | 1 | 1 | 1 | 1 | 1 | 1 |
| | Magenta | 1 | 1 | 1 | 1 | 1 | 1 | 0 | 0 | 0 | 0 | 0 | 0 | 1 | 1 | 1 | 1 | 1 | 1 |
| | Yellow | 1 | 1 | 1 | 1 | 1 | 1 | 1 | 1 | 1 | 1 | 1 | 1 | 0 | 0 | 0 | 0 | 0 | 0 |
| | White | 1 | 1 | 1 | 1 | 1 | 1 | 1 | 1 | 1 | 1 | 1 | 1 | 1 | 1 | 1 | 1 | 1 | 1 |
| Red | Red(00) Dark | 0 | 0 | 0 | 0 | 0 | 0 | 0 | 0 | 0 | 0 | 0 | 0 | 0 | 0 | 0 | 0 | 0 | 0 |
| | Red(01) | 0 | 0 | 0 | 0 | 0 | 1 | 0 | 0 | 0 | 0 | 0 | 0 | 0 | 0 | 0 | 0 | 0 | 0 |
| | Red(02) | 0 | 0 | 0 | 0 | 1 | 0 | 0 | 0 | 0 | 0 | 0 | 0 | 0 | 0 | 0 | 0 | 0 | 0 |
| | : | : | : | : | : | : | : | : | : | : | : | : | : | : | : | : | : | : | : |
| | Red(61) | 1 | 1 | 1 | 1 | 0 | 1 | 0 | 0 | 0 | 0 | 0 | 0 | 0 | 0 | 0 | 0 | 0 | 0 |
| | Red(62) | 1 | 1 | 1 | 1 | 1 | 0 | 0 | 0 | 0 | 0 | 0 | 0 | 0 | 0 | 0 | 0 | 0 | 0 |
| | Red(63) Bright | 1 | 1 | 1 | 1 | 1 | 1 | 0 | 0 | 0 | 0 | 0 | 0 | 0 | 0 | 0 | 0 | 0 | 0 |
| Green | Green(00)Dark | 0 | 0 | 0 | 0 | 0 | 0 | 0 | 0 | 0 | 0 | 0 | 0 | 0 | 0 | 0 | 0 | 0 | 0 |
| | Green(01) | 0 | 0 | 0 | 0 | 0 | 0 | 0 | 0 | 0 | 0 | 0 | 1 | 0 | 0 | 0 | 0 | 0 | 0 |
| | Green(02) | 0 | 0 | 0 | 0 | 0 | 0 | 0 | 0 | 0 | 0 | 1 | 0 | 0 | 0 | 0 | 0 | 0 | 0 |
| | : | : | : | : | : | : | : | : | : | : | : | : | : | : | : | : | : | : | : |
| | Green(61) | 0 | 0 | 0 | 0 | 0 | 0 | 1 | 1 | 1 | 1 | 0 | 1 | 0 | 0 | 0 | 0 | 0 | 0 |
| | Green(62) | 0 | 0 | 0 | 0 | 0 | 0 | 1 | 1 | 1 | 1 | 1 | 0 | 0 | 0 | 0 | 0 | 0 | 0 |
| | Green(63)Bright | 0 | 0 | 0 | 0 | 0 | 0 | 1 | 1 | 1 | 1 | 1 | 1 | 0 | 0 | 0 | 0 | 0 | 0 |
| Blue | Blue(00) Dark | 0 | 0 | 0 | 0 | 0 | 0 | 0 | 0 | 0 | 0 | 0 | 0 | 0 | 0 | 0 | 0 | 0 | 0 |
| | Blue(01) | 0 | 0 | 0 | 0 | 0 | 0 | 0 | 0 | 0 | 0 | 0 | 0 | 0 | 0 | 0 | 0 | 0 | 1 |
| | Blue(02) | 0 | 0 | 0 | 0 | 0 | 0 | 0 | 0 | 0 | 0 | 0 | 0 | 0 | 0 | 0 | 0 | 1 | 0 |
| | : | : | : | : | : | : | : | : | : | : | : | : | : | : | : | : | : | : | : |
| | Blue(61) | 0 | 0 | 0 | 0 | 0 | 0 | 0 | 0 | 0 | 0 | 0 | 0 | 1 | 1 | 1 | 1 | 0 | 1 |
| | Blue(62) | 0 | 0 | 0 | 0 | 0 | 0 | 0 | 0 | 0 | 0 | 0 | 0 | 1 | 1 | 1 | 1 | 1 | 0 |
| | Blue(63) Bright | 0 | 0 | 0 | 0 | 0 | 0 | 0 | 0 | 0 | 0 | 0 | 0 | 1 | 1 | 1 | 1 | 1 | 1 |

Product Specification

Notes 1. Contrast Ratio (CR) is defined mathematically as :
Surface Luminance with all white pixels

$$\text{Contrast Ratio} = \frac{\text{Surface Luminance with all white pixels}}{\text{Surface Luminance with all black pixels}}$$

2. Surface luminance is the center point across the LCD surface 500mm from the surface with all pixels displaying white. For more information see FIG. 2.

When $I_{BL}=6mA$, $L_{WH}= 75cd/m^2$ (Min.) $90cd/m^2$ (Typ.)

3. The variation in surface luminance, δ WHITE is determined by measuring L_{ON} at each test position 1 through 5, and then dividing the maximum L_{ON} of 5 points luminance by minimum L_{ON} of 5 points luminance. For more information see FIG. 2

$$\delta \text{ WHITE} = \text{Maximum} (L_{ON1}, L_{ON2}, \dots, L_{ON5}) \div \text{Minimum} (L_{ON1}, L_{ON2}, \dots, L_{ON5})$$

4. Response time is the time required for the display to transition from white to black (Rise Time, T_{R}) and from black to white (Decay Time, T_{D}). For additional information see FIG. 3.

5. Viewing angle is the angle at which the contrast ratio is greater than 10. The angles are determined for the horizontal or x axis and the vertical or y axis with respect to the z axis which is normal to the LCD surface. For more information see FIG. 4

6.Gray scale specification.

| Gray Level | Luminance(%) (Typ.) |
|------------|------------------------|
| L0 | 4.0 |
| L7 | 4.4 |
| L15 | 5.1 |
| L23 | 7.5 |
| L31 | 17.5 |
| L39 | 30.9 |
| L47 | 50.0 |
| L55 | 74.5 |
| L63 | 100 |

Product Specification

FIG. 2 Luminance

<measuring point for luminance variation>

<measuring point for surface luminance >

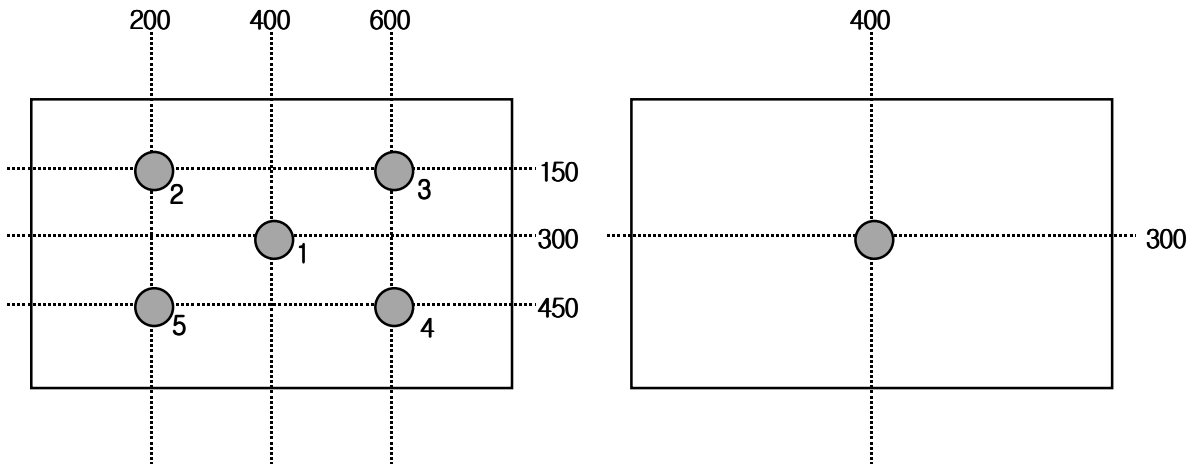
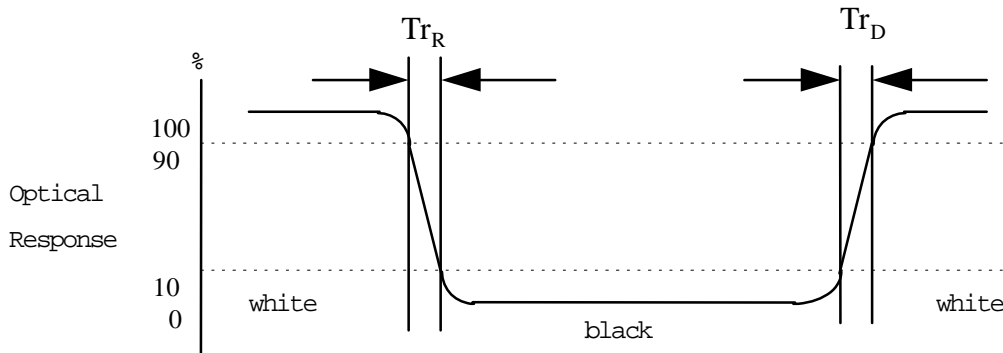

FIG. 3 Response Time

The response time is defined as the following figure and shall be measured by switching the input signal for "black" and "white".



Product Specification

FIG. 4 Viewing angle

<Definition of viewing angle range>

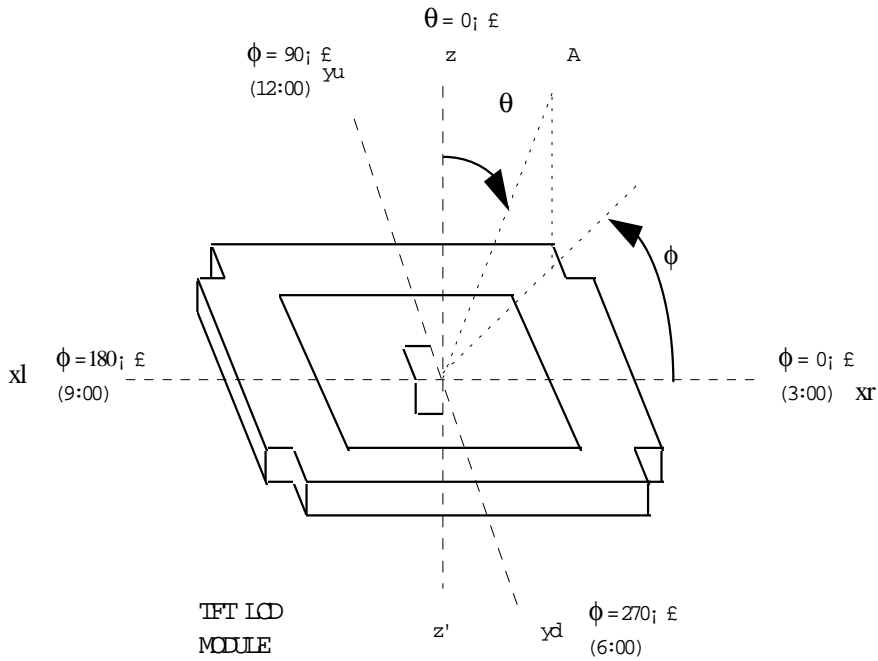

Product Specification**5. Mechanical Characteristics**

The contents provide general mechanical characteristics for the model LC121S1 LCD. In addition, the figures in the next page are detailed mechanical drawings of the LCD.

Outside dimensions :

| | |
|------------|-------------|
| Horizontal | 261 ±0.5 mm |
| Vertical | 199 ±0.5 mm |
| Depth | 6.5 ±0.3 mm |

Bezel area :

| | |
|------------|---------------|
| Horizontal | 249.2 ±0.5 mm |
| Vertical | 187.6 ±0.5 mm |

Active Display area :

| | |
|------------|----------|
| Horizontal | 246.0 mm |
| Vertical | 184.5 mm |

Weight (approximate) : 420g (Typ.), 430g(Max.)

Surface Treatment : Hard coating (3H)

Product Specification

< REAR VIEW >

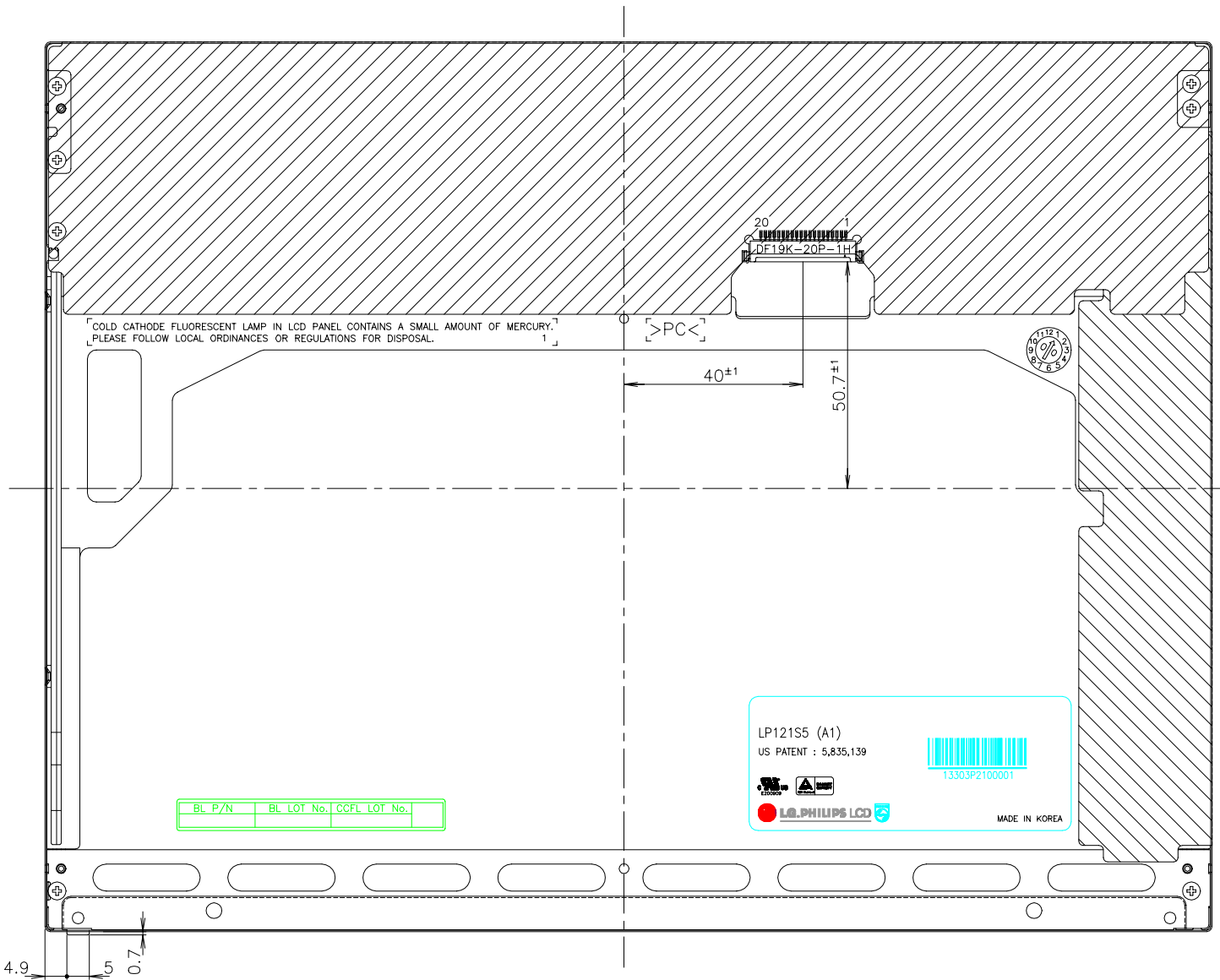

Product Specification

6. Reliability

- Environment test condition

| No. | Test Item | Conditions |
|-----|-----------------------------------|---|
| 1 | High temperature storage test | Ta = 60°C 240h |
| 2 | Low temperature storage test | Ta = -20°C 240h |
| 3 | High temperature operation test | Ta = 50°C 50%RH 240h |
| 4 | Low temperature operation test | Ta = 0°C 240h |
| 5 | Vibration test (non-operating) | Sine wave, 10~500~10Hz, 1.5G, 0.37oct/min, 3 axis, 1 hour/axis |
| 6 | Shock test (non-operating) | Half sine wave, 180G, 2ms, one shock of each six faces (i.e. run 180G 2ms for all six faces.) |
| 7 | Altitude | |
| | operating | 0 - 10,000 feet (3048m) |
| | storage/shipment | 0 - 40,000 feet (12192m) |

{Result Evaluation Criteria}

There should be no change which might affect the practical display function when the display quality test is conducted under normal operating condition.

7. International Standards

7-1. Safety

- a) UL 1950 Third Edition, Underwriters Laboratories, Inc. Jan. 28, 1995.
Standard for Safety of Information Technology Equipment Including Electrical Business Equipment.
- b) CAN/CSA C22.2 No. 950-95 Third Edition, Canadian Standards Association, Jan. 28, 1995.
Standard for Safety of Information Technology Equipment Including Electrical Business Equipment.
- c) EN 60950 : 1992 + A1 : 1993 + A2 : 1993 + A3 : 1995 + A4 : 1997 + A11 : 1997
IEC 950 : 1991 + A1 : 1992 + A2 : 1993 + A3 : 1995 + A4 : 1996
European Committee for Electrotechnical Standardization (CENELEC)
EUROPEAN STANDARD for Safety of Information Technology Equipment Including Electrical Business Equipment.

7-2. EMC

- a) ANSI C63.4 "Methods of Measurement of Radio-Noise Emissions from Low-Voltage Electrical and Electronic Equipment in the Range of 9kHz to 40GHz." American National Standards Institute(ANSI),1992.
- b) C.I.S.P.R "Limits and Methods of Measurement of Radio Interference Characteristics of Information Technology Equipment." International Special Committee on Radio Interference
- c) EN 55022 "Limits and Methods of Measurement of Radio Interference Characteristics of Information Technology Equipment." European Committee for Electrotechnical Standardization (CENELEC),1988

Product Specification

8. Packing

8-1. Designation of Lot Mark

a) Lot Mark

| | | | | | | | | | | | | |
|---|---|---|---|---|---|---|---|---|---|---|---|---|
| A | B | C | D | E | F | G | H | I | J | K | L | M |
|---|---|---|---|---|---|---|---|---|---|---|---|---|

A, B, C : SIZE
 D : YEAR
 E : MONTH
 F, G : PANEL CODE
 H : ASSEMBLY CODE
 I, J, K, L, M : SERIAL NO.

Note : 1. YEAR

| | | | | | | | | | | | |
|------|----|----|----|------|------|------|------|------|------|------|------|
| YEAR | 97 | 98 | 99 | 2000 | 2001 | 2002 | 2003 | 2004 | 2005 | 2006 | 2007 |
| Mark | 7 | 8 | 9 | 0 | 1 | 2 | 3 | 4 | 5 | 6 | 7 |

2. MONTH

| | | | | | | | | | | | | |
|-------|------|------|------|------|------|------|------|------|------|------|------|------|
| MONTH | Jan. | Feb. | Mar. | Apr. | May. | Jun. | Jul. | Aug. | Sep. | Oct. | Nov. | Dec. |
| Mark | 1 | 2 | 3 | 4 | 5 | 6 | 7 | 8 | 9 | A | B | C |

b) Location of Lot Mark

Serial NO. Is printed on the label. The label is attached to the backside of the LCD module.
 This is subject to change without prior notice.

8-2. Packing Form

a) Package quantity in one box : 10 pcs

b) Box Size : 323mm × 272mm × 276mm

9.PRECAUTIONS

Please pay attention to the followings when you use this TFT LCD module.

9.1 MOUNTING PRECAUTIONS

- (1) You must mount a module using holes arranged in four corners or four sides.
- (2) You should consider the mounting structure so that uneven force (ex. twisted stress) is not applied to the module.
And the case on which a module is mounted should have sufficient strength so that external force is not transmitted directly to the module.
- (3) Please attach a transparent protective plate to the surface in order to protect the polarizer.
Transparent protective plate should have sufficient strength in order to resist external force.
- (4) You should adopt radiation structure to satisfy the temperature specification.
- (5) Acetic acid type and chlorine type materials for the cover case are not desirable because the former generates corrosive gas of attacking the polarizer at high temperature and the latter causes circuit break by electro-chemical reaction.
- (6) Do not touch, push or rub the exposed polarizers with glass, tweezers or anything harder than HB pencil lead. And please do not rub with dust clothes with chemical treatment.
Do not touch the surface of polarizer for bare hand or greasy cloth. (Some cosmetics are detrimental to the polarizer.)
- (7) When the surface becomes dusty, please wipe gently with absorbent cotton or other soft materials like chamois soaked with petroleum benzene. Normal-hexane is recommended for cleaning the adhesives used to attach front / rear polarizers. Do not use acetone, toluene and alcohol because they cause chemical damage to the polarizer.
- (8) Wipe off saliva or water drops as soon as possible. Their long time contact with polarizer causes deformations and color fading.
- (9) Do not open the case because inside circuits do not have sufficient strength.

9.2 OPERATING PRECAUTIONS

- (1) The spike noise causes the mis-operation of circuits. It should be lower than following voltage :
 $V = \pm 200\text{mV}$ (Over and under shoot voltage).
- (2) Response time depends on the temperature. (In lower temperature, it becomes longer.)
- (3) Brightness depends on the temperature. (In lower temperature, it becomes lower.)
And in lower temperature, response time (required time that brightness is stable after turned on) becomes longer.
- (4) Be careful for condensation at sudden temperature change. Condensation makes damage to polarizer or electrical contacted parts. And after fading condensation, smear or spot will occur.
- (5) When fixed patterns are displayed for a long time, remnant image is likely to occur.
- (6) Module has high frequency circuits. Sufficient suppression to the electromagnetic interference shall be done by system manufacturers. Grounding and shielding methods may be important to minimize the interference.

9.3 ELECTROSTATIC DISCHARGE CONTROL

Since a module is composed of electronic circuits, it is not strong to electrostatic discharge. Make certain that treatment persons are connected to ground through wrist band etc . And don't touch interface pin directly.

9.4 PRECAUTIONS FOR STRONG LIGHT EXPOSURE

Strong light exposure causes degradation of polarizer and color filter.

9.5 STORAGE

When storing modules as spares for a long time, the following precautions are necessary.

- (1) Store them in a dark place. Do not expose the module to sunlight or fluorescent light. Keep the temperature between 5°C and 35°C at normal humidity.
- (2) The polarizer surface should not come in contact with any other object.
It is recommended that they be stored in the container in which they were shipped.

9.6 HANDLING PRECAUTIONS FOR PROTECTION FILM

- (1) When the protection film is peeled off, static electricity is generated between the film and polarizer.
This should be peeled off slowly and carefully by people who are electrically grounded and with well ion- blown equipment or in such a condition, etc.
- (2) The protection film is attached to the polarizer with a small amount of glue. If some stress is applied to rub the protection film against the polarizer during the time you peel off the film, the glue is apt to remain on the polarizer.
Please carefully peel off the protection film without rubbing it against the polarizer.
- (3) When the module with protection film attached is stored for a long time, sometimes there remains a very small amount of glue still on the polarizer after the protection film is peeled off.
- (4) You can remove the glue easily. When the glue remains on the polarizer surface or its vestige is recognized, please wipe them off with absorbent cotton waste or other soft material like chamois soaked with normal-hexane .