

SPECIFICATION FOR APPROVAL

- (?) Preliminary Specification
() Final Specification

Title	37.0" WXGA TFT LCD
--------------	---------------------------

BUYER	-
MODEL	-

SUPPLIER	LG.Philips LCD Co., Ltd.
*MODEL	LC370W01
MODEL	A5

*When you obtain standard approval,
please use the above model name without suffix

APPROVED BY	SIGNATURE DATE
/	_____
/	_____
/	_____

Please return 1 copy for your confirmation with your signature and comments.

APPROVED BY	SIGNATURE DATE
M.H Park / G.Manager	_____
REVIEWED BY	
J.H Yoon / Manager	_____
PREPARED BY	
S.S Kim / Engineer	_____

**MNT/TV Products Engineering Dept.
LG. Philips LCD Co., Ltd**

Product Specification

Contents

No	ITEM	Page
	COVER	1
	CONTENTS	2
	RECORD OF REVISIONS	3
1	GENERAL DESCRIPTION	4
2	ABSOLUTE MAXIMUM RATINGS	5
3	ELECTRICAL SPECIFICATIONS	6
3-1	ELECTRICAL CHARACTREISTICS	6
3-2	INTERFACE CONNECTIONS	8
3-3	SIGNAL TIMING SPECIFICATIONS	12
3-4	SIGNAL TIMING WAVEFORMS	13
3-5	COLOR INPUT DATA REFERNECE	14
3-6	POWER SEQUENCE	15
4	OPTICAL SFECIFICATIONS	16
5	MECHANICAL CHARACTERISTICS	20
6	RELIABILITY	23
7	INTERNATIONAL STANDARDS	24
7-1	SAFETY	24
7-2	EMC	24
8	PACKING	25
8-1	DESIGNATION OF LOT MARK	25
8-2	PACKING FORM	25
9	PRECAUTIONS	26

Product Specification

1. General Description

LC370W01 is a Color Active Matrix Liquid Crystal Display with an integral Cold Cathode Fluorescent Lamp(CCFL) backlight system. The matrix employs a-Si Thin Film Transistor as the active element. It is a transmissive type display operating in the normally black mode. It has a 37.02 inch diagonally measured active display area with WXGA resolution (768 vertical by 1366 horizontal pixel array) Each pixel is divided into Red, Green and Blue sub-pixels or dots which are arranged in vertical stripes. Gray scale or the luminance of the sub-pixel color is determined with a 8-bit gray scale signal for each dot, thus, presenting a palette of more than 16,7M(True) colors.

It has been designed to apply the 8Bit 1 port LVDS interface.

It is intended to support LCD TV, PCTV where high brightness, super wide viewing angle, high color gamut, high color depth, and fast response time are important.

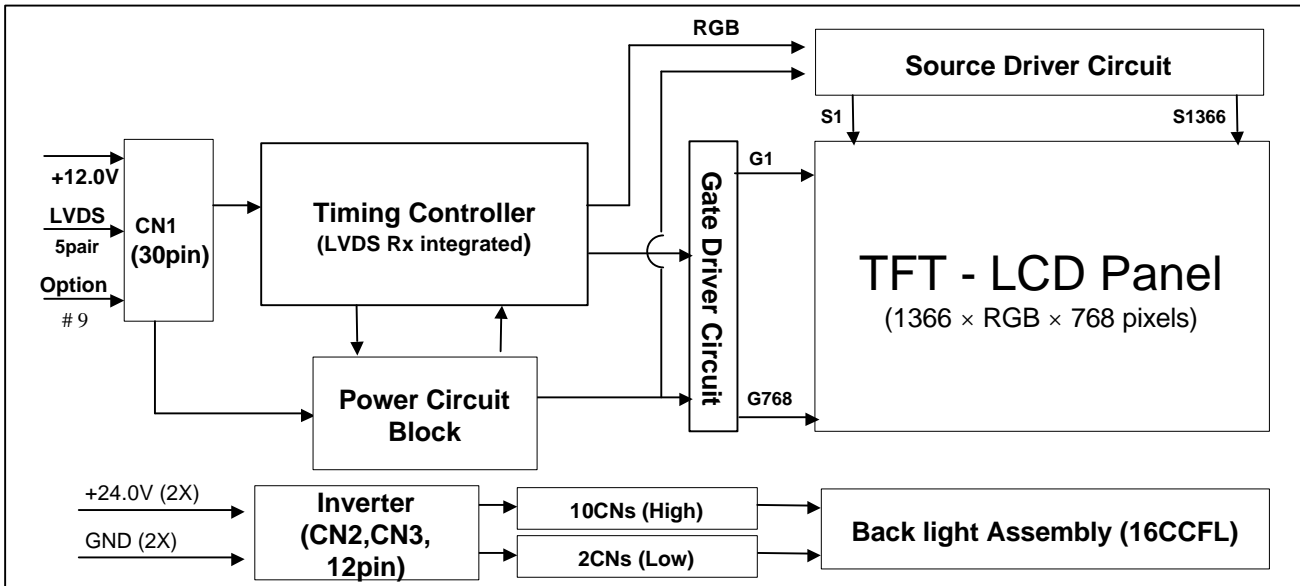

General Features

Active Screen Size	37.02 inches(940.3mm) diagonal
Outline Dimension	877.0/878.0(H) x 516.8(V) x 55.5(D) mm(Typ.)
Pixel Pitch	0.200mm x 0.600mm x RGB
Pixel Format	1366 horiz. By 768 vert. Pixels RGB strip arrangement
Color Depth	8bit, 16,7 M colors
Luminance, White	500 cd/m ² (Center 1 points Typ.)
Viewing Angle (CR>10)	Viewing Angle Free (R/L 176(Typ.), U/D 176(Typ))
Power Consumption	Total 136Watt (Typ.) (Logic=5.4W, Lamp=130W [I _{BL} =6.0mA]) –Not Fixed
Weight	11,500 (Typ.)
Display Operating Mode	Transmissive mode, normally black
Surface Treatment	Hard coating(3H), Anti-glare treatment of the front polarizer,

Product Specification

2. Absolute Maximum Ratings

The following are maximum values which, if exceeded, may cause faulty operation or damage to the unit.

Table 1. ABSOLUTE MAXIMUM RATINGS

Parameter		Symbol	Values		Units	Notes
			Min	Max		
Power Input Voltage	LCM	V _{LCD}	-0.3	+14.0	Vdc	at 25 ± 2 °C
	Backlight inverter	V _{BL}	21.6	+27.0	Vdc	
ON/OFF Control Voltage		V _{ON/OFF}	-0.3	+5.25	Vdc	
Brightness Control Voltage		V _{Br}	0	+3.3	Vdc	
Operating Temperature		T _{OP}	0	+40	°C	1
Storage Temperature		T _{ST}	-20	+50	°C	
Operating Ambient Humidity		H _{OP}	10	90	%RH	
Storage Humidity		H _{ST}	10	90	%RH	

Note : 1. Temperature and relative humidity range are shown in the figure below.
Wet bulb temperature should be 39 °C Max, and no condensation of water.

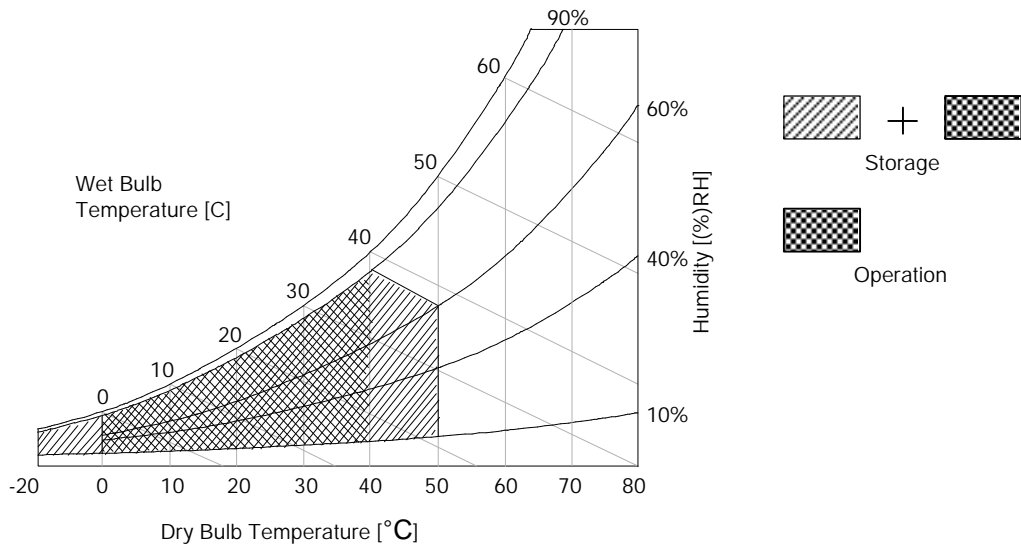

Product Specification

3. Electrical Specifications

3-1. Electrical Characteristics

It requires two power inputs. One is employed to power the LCD electronics and to drive the TFT array and liquid crystal. The second input power for the CCFL/Backlight, is to power inverter.

Table 2_1. ELECTRICAL CHARACTERISTICS

Parameter	Symbol	Values			Unit	Notes
		Min	Typ	Max		
MODULE :						
Power Supply Input Voltage	V _{LCD}	11.4	12.0	12.6	Vdc	
Power Supply Input Current	I _{LCD}	-	450	518	mA	1
		-	600	780	mA	2
Power Consumption	P _{LCD}		5.4	6.2	Watt	1
Rush current	I _{RUSH}	-	-	3.0	A	3

Note :

1. The specified current and power consumption are under the $V_{LCD}=12.0V$, $25 \pm 2^{\circ}C$, $f_V=60Hz$ condition whereas mosaic pattern(8 x 6) is displayed and f_V is the frame frequency.
2. The current is specified at the maximum current pattern.
3. The duration of rush current is about 2ms and rising time of power Input is 1ms(min.).

White : 255Gray
Black : 0Gray

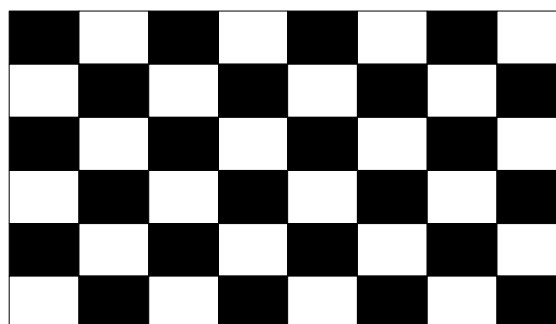

Mosaic Pattern(8 x 6)

Product Specification

Table 2_2. ELECTRICAL CHARACTERISTICS

Parameter	Symbol	Values			Unit	Notes		
		Min	Typ	Max				
Inverter :								
Power Supply Input Voltage	VBL	22.8	24.0	25.2	Vdc	1		
Power Supply Input Current	IBL	-	5.4	TBD	A	1		
Power Consumption	PBL	-	130	TBD	W	1		
Input Voltage for Control System Signals	Brightness Adjust	VBR	0		3.3	Vdc	2	
	On/Off	On	V on	4.0	5.0	5.25	Vdc	
		Off	V off	-0.3	0	0.5	Vdc	
Lamp :								
Life Time		50,000			Hrs	3		

Notes :

- Electrical characteristics are determined after the unit has been 'ON' and stable for approximately 120Min at 25±2°C

The specified current and power consumption are under the typical supply Input voltage, 24.0V. it is total power consumption.

The ripple voltage of the power supply input voltage is under 0.5 Vp-p.

Inrush current of the power supply input current is under +10% of the typical current.

- Brightness Control.

This VBR Voltage control brightness.

VBR Voltage	Function
3.3V	Maximum Brightness (100%)
0V	Minimum Brightness.(20~30%, but not fixed)

- The life is determined as the time at which luminance of the lamp is 50% compared to that of initial value at the typical lamp current on condition of continuous operating at 25 ± 2°C.

Product Specification

3-2. Interface Connections

This LCD employs Two interface connections, a 30 pin connector is used for the module electronics and a 12Pin Connector is used for the integral backlight system.

3-2-1. LCD Module

- LCD Connector(CN1) : FI-X30SSL-HF (Manufactured by JAE) or Equivalent
- Mating Connector : FI-X30C2L (Manufactured by JAE) or Equivalent

Table 3. MODULE CONNECTOR(CN1) PIN CONFIGURATION

Pin No	Symbol	Description	Output Pin # (LVDS Tx)
1	VLCD	Power Supply +12.0V	
2	VLCD	Power Supply +12.0V	
3	VLCD	Power Supply +12.0V	
4	VLCD	Power Supply +12.0V	
5	GND	Ground	
6	GND	Ground	
7	GND	Ground	
8	GND	Ground	
9	Select	Select LVDS Data format	Note 1
10	NC	NC	
11	GND	Ground	
12	RA-	LVDS Receiver Signal(-)	
13	RA+	LVDS Receiver Signal(+)	
14	GND	Ground	
15	RB-	LVDS Receiver Signal(-)	
16	RB+	LVDS Receiver Signal(+)	
17	GND	Ground	
18	RC-	LVDS Receiver Signal(-)	
19	RC+	LVDS Receiver Signal(+)	
20	GND	Ground	
21	RCLK-	LVDS Receiver Clock Signal(-)	
22	RCLK+	LVDS Receiver Clock Signal(+)	
23	GND	Ground	
24	RD-	LVDS Receiver Signal(-)	
25	RD+	LVDS Receiver Signal(+)	
26	GND	Ground	
27	NC	NC	
28	NC	NC	
29	GND	Ground	
30	GND	Ground	

- Note: 1. If Pin9 is Ground, Interface format is "LG", and if Pin9 is Vcc(3.3V), Interface format is "DISM"
See page 9 and 10.
2. Pin30 should be ground, this pin is necessary for LCD test.
 3. All GND(ground) pins should be connected together, which should be also connected to the LCD's metal frame.
 4. All VLCD (power input) pins should be connected together.
 5. Input Level of LVDS signal is based on the IEA 664 Standard.

Product Specification

Table 4. REQUIRED SIGNAL ASSIGNMENT FOR LVDS TRANSMITTER (Pin9="L" or "Open")

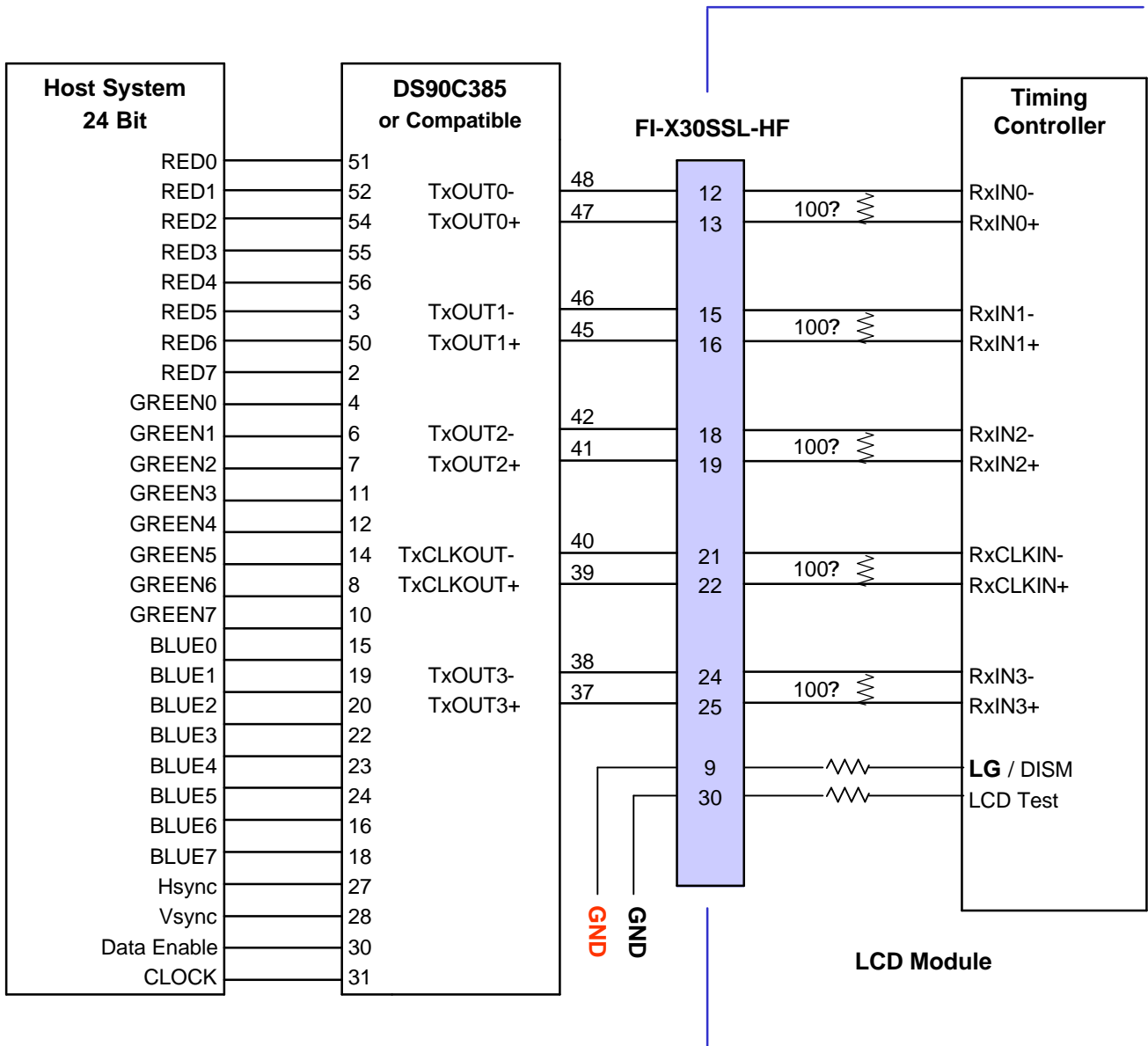

- Note: 1. The LCD Module uses a 100 Ohm resistor between positive and negative lines of each receiver input.
 2. Refer to LVDS Transmitter Data Sheet for detail descriptions. (DS90C385 or Compatible)
 3. '7' means MSB and '0' means LSB at R,G,B pixel data.

Table 5. REQUIRED SIGNAL ASSIGNMENT FOR LVDS TRANSMITTER (Pin9="H")

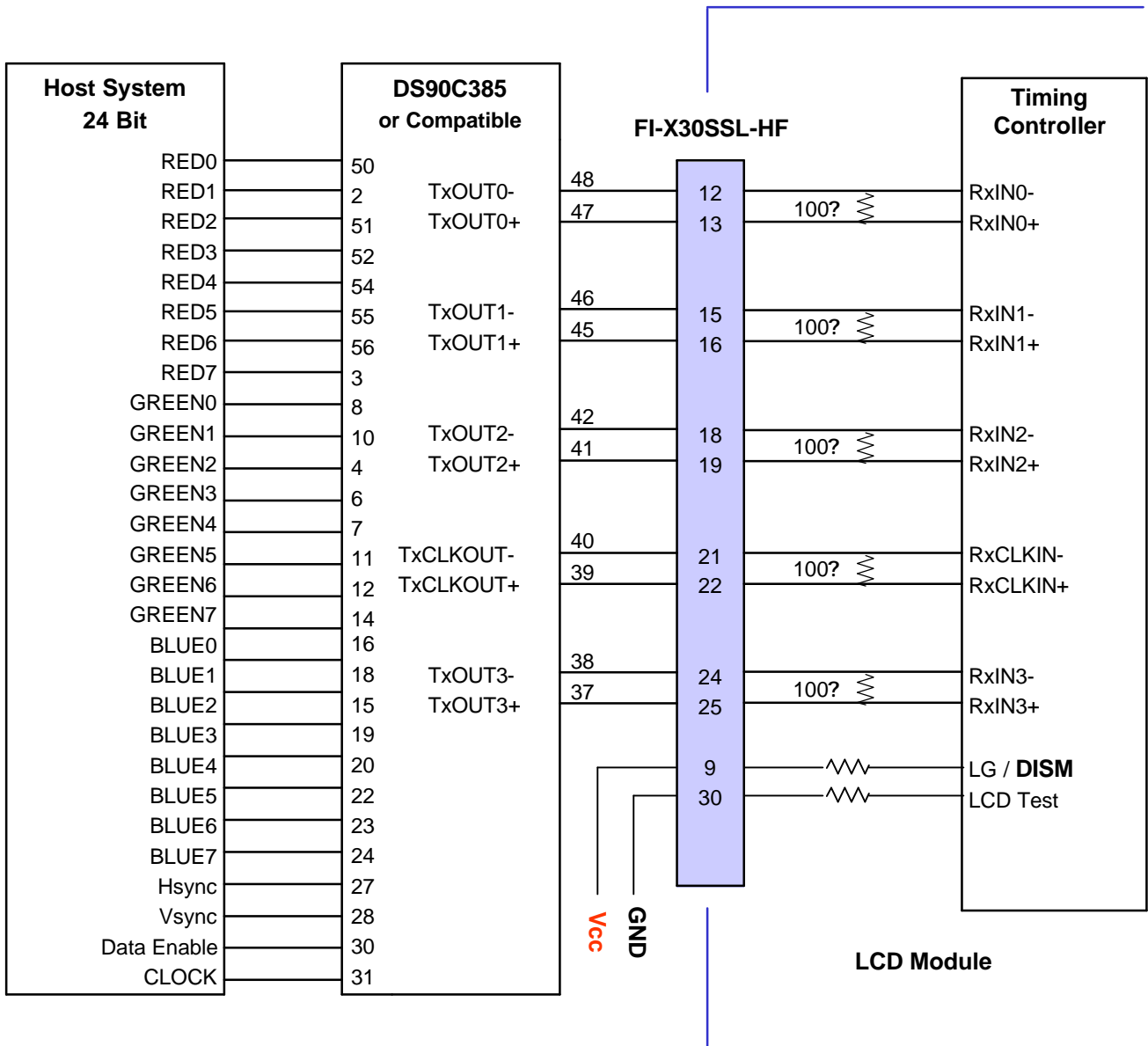

- Note: 1. The LCD Module uses a 100 Ohm resistor between positive and negative lines of each receiver input.
 2. Refer to LVDS Transmitter Data Sheet for detail descriptions. (DS90C385 or Compatible)
 3. '7' means MSB and '0' means LSB at R,G,B pixel data.

Product Specification

3-2-2. Backlight Inverter

- Inverter Connector : S12B-PH-SM3(manufactured by JST) or Equivalent
- Mating Connector : PHR-12 or Equivalent

Table 6. INVERTER CONNECTOR PIN CONFIGURATION

Pin No	Symbol	Description	Remarks
1	VBL	Power Supply +24.0V	
2	VBL	Power Supply +24.0V	
3	VBL	Power Supply +24.0V	
4	VBL	Power Supply +24.0V	
5	VBL	Power Supply +24.0V	
6	GND	POWER GND	Note 1
7	GND	POWER GND	
8	GND	POWER GND	
9	GND	POWER GND	
10	GND	POWER GND	
11	VBR	0V ~ 3.3V	Note 2
12	On/Off	0V ~ 5.0V	Note 3

Notes : 1. GND is connected to the LCD's metal frame.

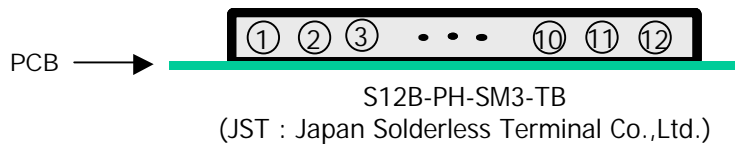

- 2. 0V : Minimum Brightness.
3.3V : Maximum Brightness.
- 3. On : 4.0 ~ 5.25V
Off : -0.3 ~ 0.5V

Product Specification

3-3. Signal Timing Specifications

This is the signal timing required at the input of the LVDS Transmitter. All of the interface signal timing should be satisfied with the following specifications for it's proper operation.

Table 7. Timing Table

ITEM	Symbol		Min	Typ	Max	Unit	Note
DCLK	Period	tCLK	12.2	13.8	14.7	ns	
	Frequency	-	68	72	80	MHz	
Hsync	Period	tHP	1416	1528	1776	tCLK	
	Frequency	fH	45	47.4	50	KHz	
	Width	tWH	8	32	-	tCLK	
Vsync	Period	tVP	775	790	1063	tHP	
	Frequency	fV	47	60	63	Hz	Note 1) PAL : 47~53Hz NTSC : 57~63Hz
	Width	tWV	2	5	-	tHP	
DE (Data Enable)	Horizontal Valid	tHV	1366	1366	1366	tCLK	
	Horizontal Back Porch	tHBP	16	80	-		
	Horizontal Front Porch	tHFP	24	48	-		
	Horizontal Blank	-	48	160	tHP- tHV		
	Vertical Valid	tVv	768	768	768	tHP	
	Vertical Back Porch	tVBP	4	15	-		
	Vertical Front Porch	tVFP	1	2	-		
	Vertical Blank	-	7	22	tVP- tVv		

Note: Hsync period and Hsync width-active should be even number times of tCLK. If the value is odd number times of tCLK, display control signal can be asynchronous. In order to operate this LCM a Hsync, Vsync, and DE(data enable) signals should be used.

1. : The performance of the electro-optical characteristics may be influenced by variance of the vertical refresh rates.
2. Vsync and Hsync should be keep the above specification.
3. Hsync Period, Hsync Width, and Horizontal Back Porch should be any times of character number(8).

3-4. Signal Timing Waveforms

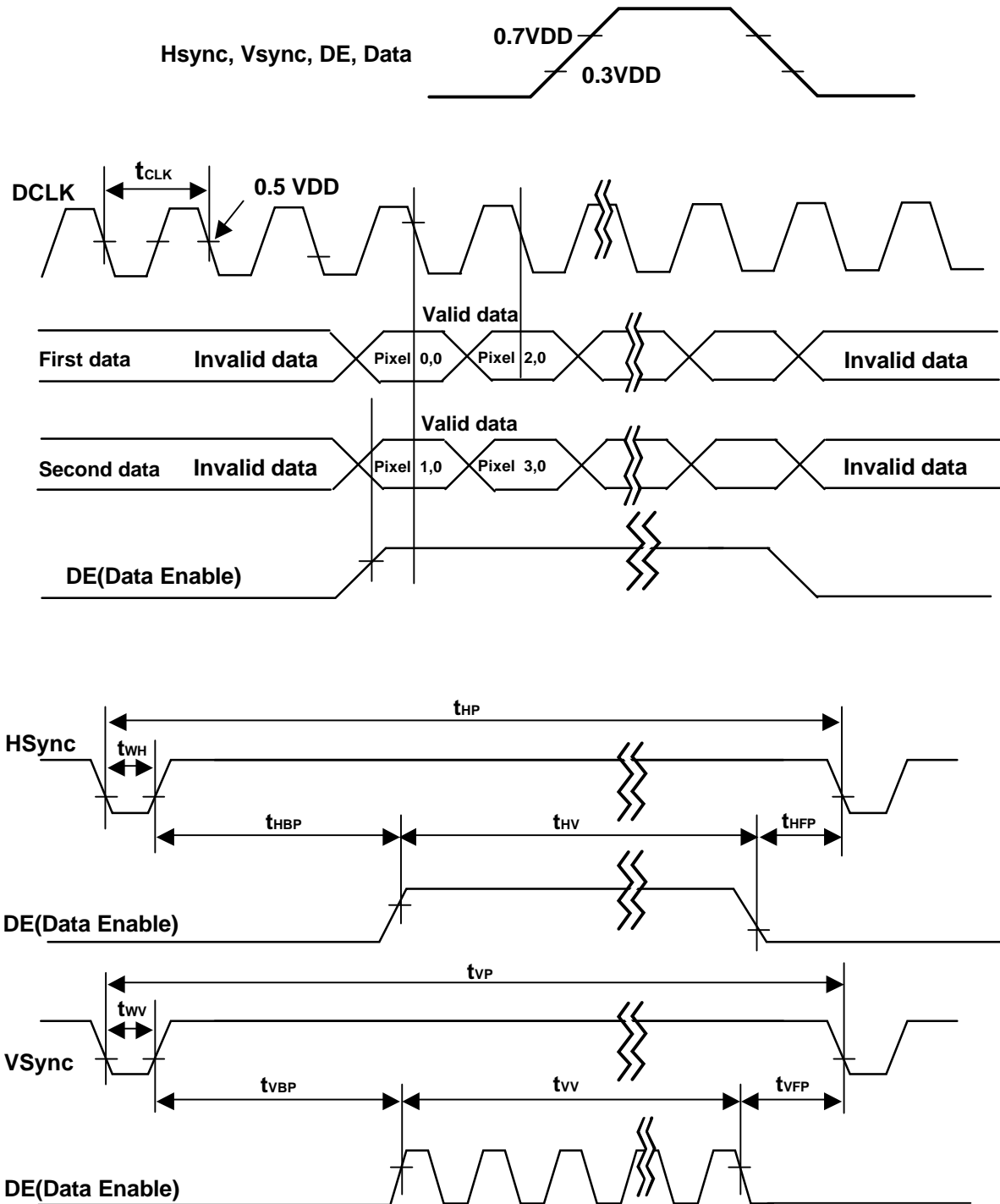

Product Specification

3-5. Color Data Reference

The Brightness of each primary color(red,green,blue) is based on the 8-bit gray scale data input for the color; the higher the binary input, the brighter the color. The table below provides a reference for color versus data input.

Table 8. COLOR DATA REFERENCE

Color		Input Color Data																							
		RED								GREEN								BLUE							
		MSB							LSB	MSB							LSB	MSB							LSB
		R7	R6	R5	R4	R3	R2	R1	R0	G7	G6	G5	G4	G3	G2	G1	G0	B7	B6	B5	B4	B3	B2	B1	B0
Basic Color	Black	0	0	0	0	0	0	0	0	0	0	0	0	0	0	0	0	0	0	0	0	0	0	0	0
	Red (255)	1	1	1	1	1	1	1	1	0	0	0	0	0	0	0	0	0	0	0	0	0	0	0	0
	Green (255)	0	0	0	0	0	0	0	0	1	1	1	1	1	1	1	1	0	0	0	0	0	0	0	0
	Blue (255)	0	0	0	0	0	0	0	0	0	0	0	0	0	0	0	0	1	1	1	1	1	1	1	1
	Cyan	0	0	0	0	0	0	0	0	1	1	1	1	1	1	1	1	1	1	1	1	1	1	1	1
	Magenta	1	1	1	1	1	1	1	1	0	0	0	0	0	0	0	0	1	1	1	1	1	1	1	1
	Yellow	1	1	1	1	1	1	1	1	1	1	1	1	1	1	1	1	0	0	0	0	0	0	0	0
	White	1	1	1	1	1	1	1	1	1	1	1	1	1	1	1	1	1	1	1	1	1	1	1	1
RED	RED (000) Dark	0	0	0	0	0	0	0	0	0	0	0	0	0	0	0	0	0	0	0	0	0	0	0	0
	RED (001)	0	0	0	0	0	0	0	1	0	0	0	0	0	0	0	0	0	0	0	0	0	0	0	0
							
	RED (254)	1	1	1	1	1	1	1	0	0	0	0	0	0	0	0	0	0	0	0	0	0	0	0	0
	RED (255)	1	1	1	1	1	1	1	1	0	0	0	0	0	0	0	0	0	0	0	0	0	0	0	0
GREEN	GREEN (000) Dark	0	0	0	0	0	0	0	0	0	0	0	0	0	0	0	0	0	0	0	0	0	0	0	0
	GREEN (001)	0	0	0	0	0	0	0	0	0	0	0	0	0	0	0	1	0	0	0	0	0	0	0	0
							
	GREEN (254)	0	0	0	0	0	0	0	0	1	1	1	1	1	1	1	0	0	0	0	0	0	0	0	0
	GREEN (255)	0	0	0	0	0	0	0	0	1	1	1	1	1	1	1	1	0	0	0	0	0	0	0	0
BLUE	BLUE (000) Dark	0	0	0	0	0	0	0	0	0	0	0	0	0	0	0	0	0	0	0	0	0	0	0	0
	BLUE (001)	0	0	0	0	0	0	0	0	0	0	0	0	0	0	0	0	0	0	0	0	0	0	0	1
							
	BLUE (254)	0	0	0	0	0	0	0	0	0	0	0	0	0	0	0	0	1	1	1	1	1	1	1	0
	BLUE (255)	0	0	0	0	0	0	0	0	0	0	0	0	0	0	0	0	1	1	1	1	1	1	1	1

Note : Users should be input true 8 Bit data streams via LVDS transmitter.

3-6. Power Sequence

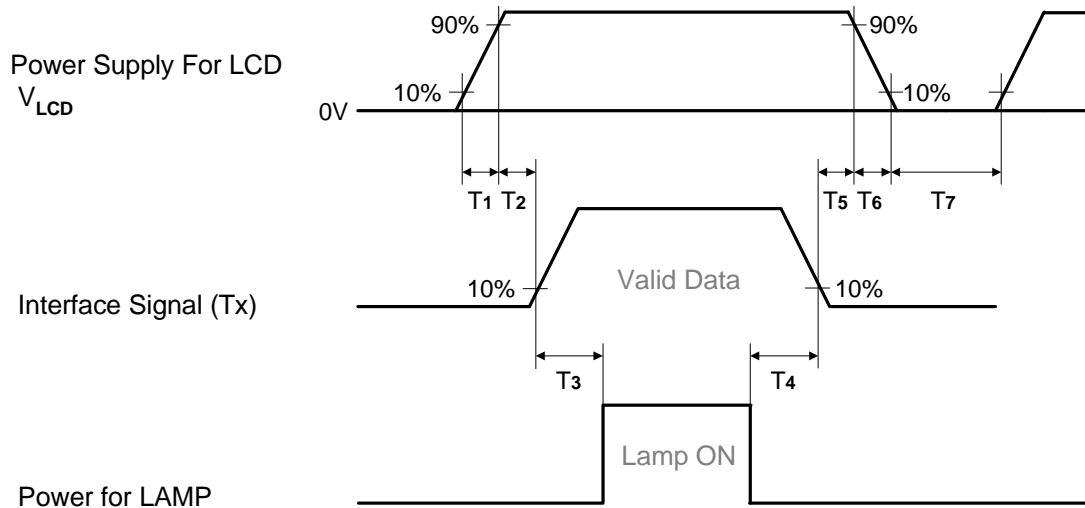

Table 9. POWER SEQUENCE

Parameter	Values			Units
	Min	Typ	Max	
T1	0.5	-	10	ms
T2	0.5	-	50	ms
T3	200	-	-	ms
T4	200	-	-	ms
T5	0.5	-	50	ms
T6	-	-	100	ms
T7	2.0	-	-	s

- Notes :
1. Please avoid floating state of interface signal at invalid period.
 2. When the interface signal is invalid, be sure to pull down the power supply for LCD V_{LCD} to 0V.
 3. Lamp power must be turn on after power supply for LCD an interface signal are valid.

Product Specification

4. Optical Specification

Optical characteristics are determined after the unit has been 'ON' and stable for approximately 120Min in a dark environment at $25\pm 2^{\circ}\text{C}$. The values specified are at an approximate distance 50cm from the LCD surface at a viewing angle of Φ and θ equal to 0° .

FIG. 1 presents additional information concerning the measurement equipment and method.

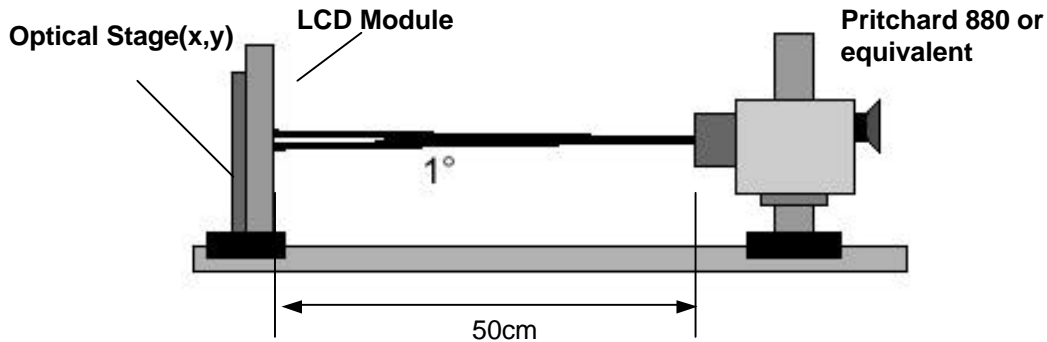

FIG. 1 Optical Characteristic Measurement Equipment and Method

Table 10. OPTICAL CHARACTERISTICS

$T_a = 25\pm 2^{\circ}\text{C}$, $V_{LCD} = 12.0\text{V}$, $f_v = 60\text{Hz}$, $D_{clk} = 72\text{MHz}$, $DL = 1.0$

Parameter	Symbol	Values			Units	Notes	
		Min	Typ	Max			
Contrast Ratio	CR	350	500			1	
Surface Luminance, white	L_{WH}	400	500		cd/m^2	2	
Luminance Variation	δ_{WHITE} 5P			1.3		3	
Response Time (Gray-to-Gray)	Rise Time	Tr_R	12	-	ms	4	
	Decay Time	Tr_D	12	-	ms	4	
Color Coordinates [CIE1931]	RED	R_x	0.640	Typ +0.03	Not fixed		
		R_y	0.341				
	GREEN	G_x	0.287				
		G_y	0.610				
	BLUE	B_x	0.146				
		B_y	0.069				
	WHITE	W_x	0.285				
	W_y	0.293					
Viewing Angle (CR>10)							
	x axis, right($\phi=0^{\circ}$)	θ_r	85	88	-	degree	5
	x axis, left ($\phi=180^{\circ}$)	θ_l	85	88	-		
	y axis, up ($\phi=90^{\circ}$)	θ_u	85	88	-		
	y axis, down ($\phi=270^{\circ}$)	θ_d	85	88	-		
Gray Scale						6	

Product Specification

Notes 1. Contrast Ratio(CR) is defined mathematically as :

$$\text{Contrast Ratio} = \frac{\text{Surface Luminance with all white pixels}}{\text{Surface Luminance with all black pixels}}$$

It is measured at center point(1)

2. Surface luminance is luminance value at center point (1) across the LCD surface 50cm from the surface with all pixels displaying white. For more information see FIG 2.
3. The variation in surface luminance , δ WHITE is defined as :

$$\delta \text{ WHITE}(5P) = \text{Maximum}(L_{on1}, L_{on2}, L_{on3}, \dots, L_{on5}) / \text{Minimum}(L_{on1}, L_{on2}, L_{on3}, \dots, L_{on5})$$
 Where L_{on1} to L_{on5} are the luminance with all pixels displaying white at 5 locations .
 For more information see FIG 2.
4. Response time is the time required for the display to transition from black to white (Rise Time, Tr_R) and from white to black (Decay Time, Tr_D). For additional information see FIG 3.
5. Viewing angle is the angle at which the contrast ratio is greater than 10. The angles are determined for the horizontal or x axis and the vertical or y axis with respect to the z axis which is normal to the LCD surface. For more information see FIG 4.
6. Gray scale specification
 Gamma Value is approximately 2.2. For more information see Table 11.

Table 11. Gray Scale Specification

Gray Level	Luminance [%] (Typ)
L0	0.20
L15	0.32
L31	0.95
L47	2.30
L63	4.48
L79	7.43
L95	11.20
L111	15.54
L127	20.14
L143	25.88
L159	32.90
L175	41.02
L191	49.91
L207	60.45
L223	72.24
L239	86.9
L255	100

Product Specification

Measuring point for surface luminance & measuring point for luminance variation

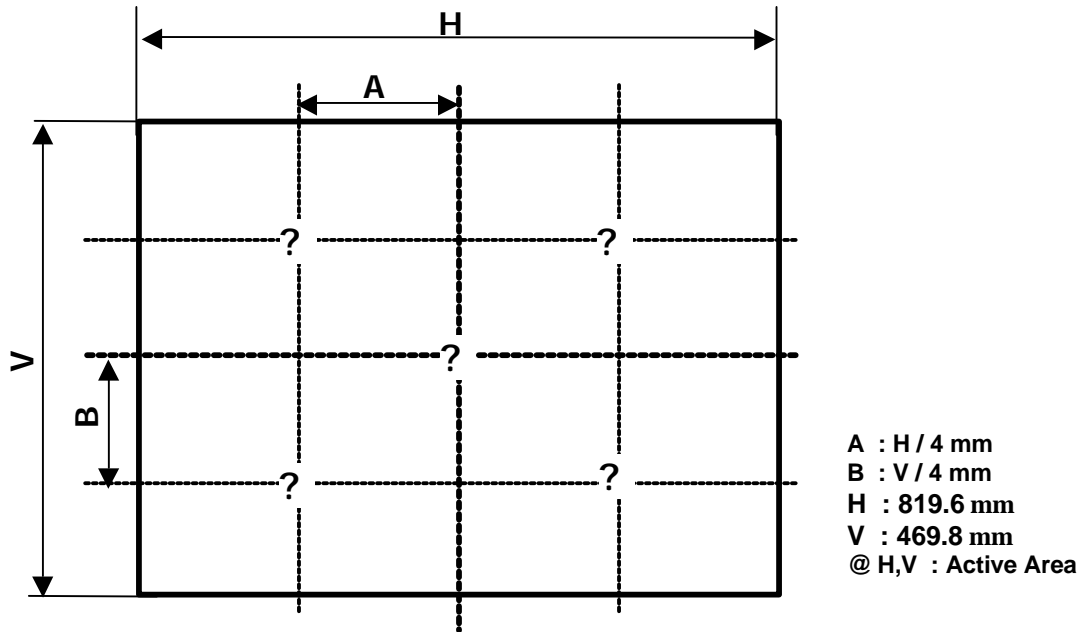

FIG. 2 Measure Point for Luminance

The response time is defined as the following figure and shall be measured by switching the input signal for "Gray(N)" and "Gray(N+1)".

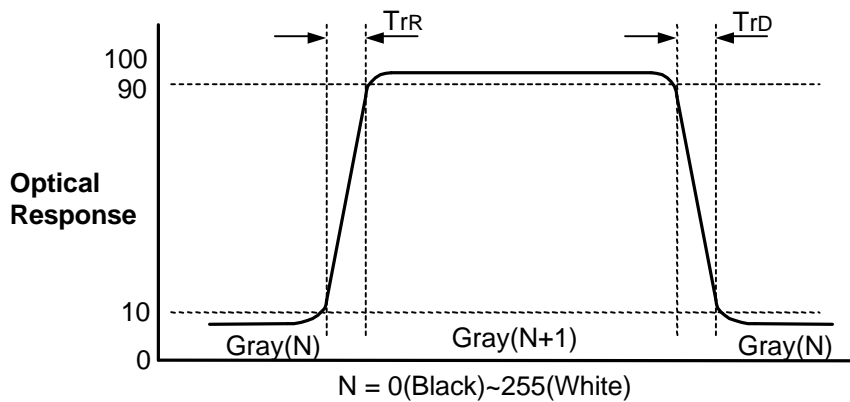

FIG. 3 Response Time

Product Specification

Dimension of viewing angle range

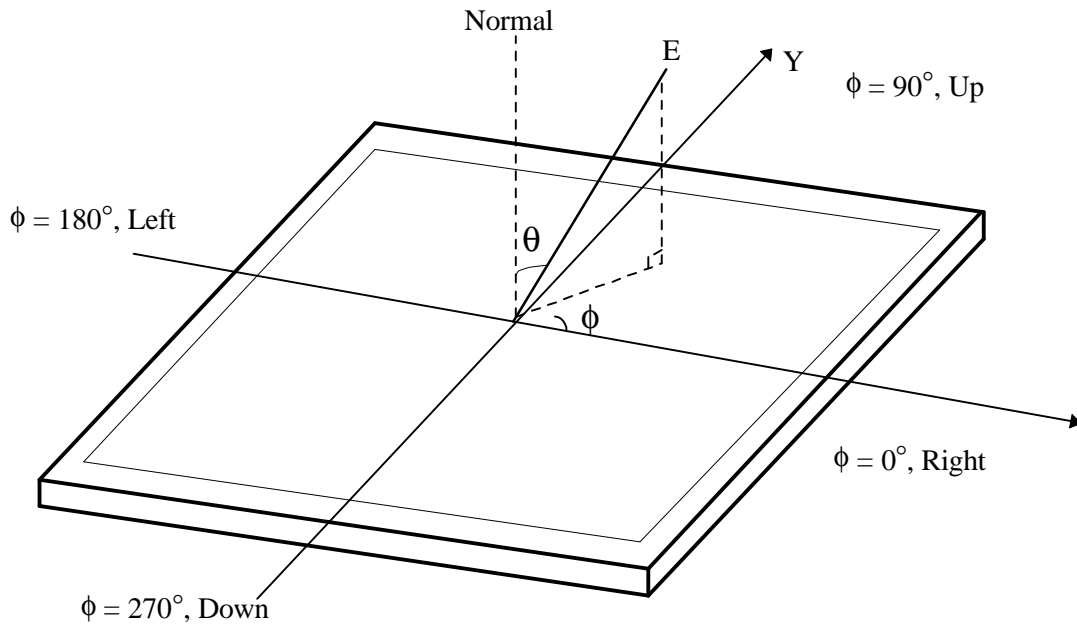

FIG. 4 Viewing angle

Product Specification

5. Mechanical Characteristics

The contents provide general mechanical characteristics. In addition the figures in the next page are detailed mechanical drawing of the LCD.

Outline Dimension	Horizontal	877.0 mm / 878.0mm(Inverter)
	Vertical	516.8 mm
	Depth	55.5 mm
Bezel Area	Horizontal	826.6mm
	Vertical	469.8mm
Active Display Area	Horizontal	819.6mm
	Vertical	460.8mm
Weight	11,500 (Typ.)/12,000(Max)	
Surface Treatment	Hard coating(3H) Anti-glare treatment of the front polarizer	

Notes : Please refer to a mechanic drawing in terms of tolerance at the next page.

Product Specification

<REAR VIEW>

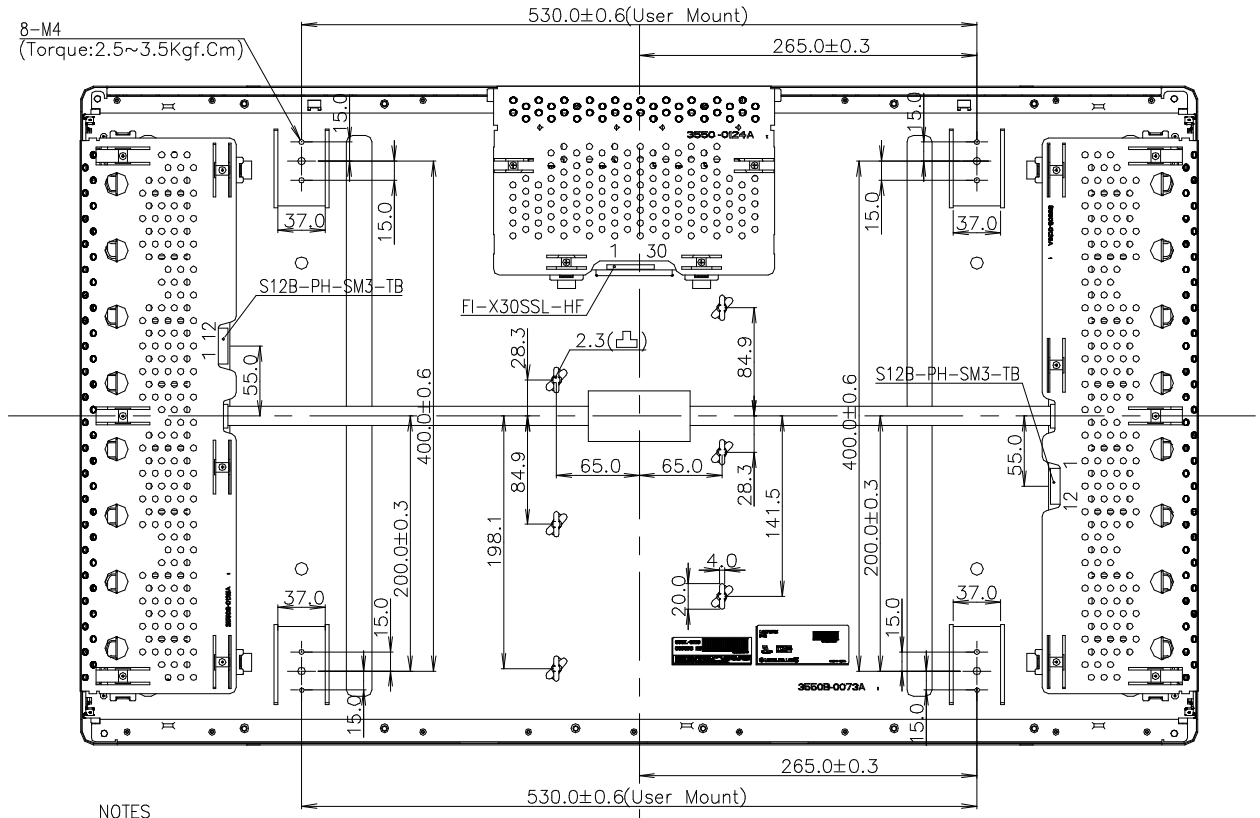

NOTES

1. Unspecified tolerances to be ± 0.5 .
2. This drawing is only preliminary data and can be changed without previous notice.
3. Tilt and partial disposition tolerance of display area as follow.
 - 1) Y-Direction : $|A-B| \leq 1.0$
 - 2) X-Direction : $|C-D| \leq 1.0$

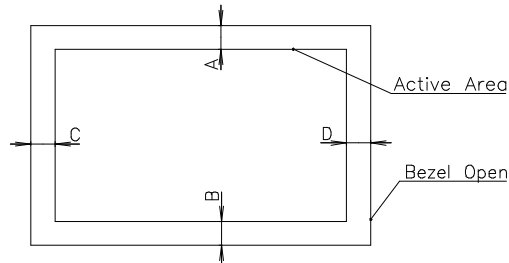

4. The same shape is same dimension.

Product Specification

6. Reliability

Environment test condition

No	Test Item	Condition
1	High temperature storage test	Ta= 50°C 240h
2	Low temperature storage test	Ta= -20°C 240h
3	High temperature operation test	Ta= 40°C 50%RH 240h
4	Low temperature operation test	Ta= 0°C 240h
5	Vibration test (non-operating)	TBD
6	Shock test (non-operating)	TBD
7	Humidity condition Operation	Ta= 40 °C ,90%RH
8	Altitude operating storage / shipment	0 - 14,000 feet(4267.2m) 0 - 40,000 feet(12192m)

7. International standards

7-1. Safety

- a) UL 60950, Third Edition, Underwriters Laboratories, Inc., Dated Dec. 11, 2000.
Standard for Safety of Information Technology Equipment, Including Electrical Business Equipment.
- b) CAN/CSA C22.2, No. 60950, Third Edition, Canadian Standards Association, Dec. 1, 2000.
Standard for Safety of Information Technology Equipment, Including Electrical Business Equipment.
- c) EN 60950 : 2000, Third Edition
IEC 60950 : 1999, Third Edition
European Committee for Electrotechnical Standardization(CENELEC)
EUROPEAN STANDARD for Safety of Information Technology Equipment Including Electrical Business Equipment.

7-2. EMC

- a) ANSI C63.4 "Methods of Measurement of Radio-Noise Emissions from Low-Voltage Electrical and Electrical Equipment in the Range of 9kHz to 40GHz. "American National Standards Institute(ANSI), 1992
- b) C.I.S.P.R "Limits and Methods of Measurement of Radio Interface Characteristics of Information Technology Equipment." International Special Committee on Radio Interference.
- c) EN 55022 "Limits and Methods of Measurement of Radio Interface Characteristics of Information Technology Equipment." European Committee for Electrotechnical Standardization.(CENELEC), 1998
(Including A1: 2000)

Product Specification

8. Packing

8-1. Designation of Lot Mark

a) Lot Mark

A	B	C	D	E	F	G	H	I	J	K	L	M
---	---	---	---	---	---	---	---	---	---	---	---	---

A,B,C : SIZE(INCH)

D : YEAR

F : PANEL CODE

H : ASSEMBLY CODE

E : MONTH

G : FACTORY CODE

I,J,K,L,M : SERIAL NO.

Note

1. YEAR

Year	97	98	99	2000	2001	2002	2003	2004	2005	2006	2007
Mark	7	8	9	0	1	2	3	4	5	6	7

2. MONTH

Month	Jan	Feb	Mar	Apr	May	Jun	Jul	Aug	Sep	Oct	Nov	Dec
Mark	1	2	4	4	5	6	7	8	9	A	B	C

3. PANEL CODE

Panel Code	P1 Factory	P2 Factory	P3 Factory	P4 Factory	P5 Factory	Hydis Panel
Mark	1	2	3	4	5	H

4. FACTORY CODE

Factory Code	LPL Gumi	LPL Nanjing
Mark	K	C

5. SERIAL NO.

Year	1 ~ 99999	100000 ~
Mark	00001 ~ 99999	A0001 ~ A9999, , Z9999

b) Location of Lot Mark

Serial NO. is printed on the label. The label is attached to the backside of the LCD module.
This is subject to change without prior notice.

8-2. Packing Form

a) Package quantity in one box : 3 pcs

b) Box Size : 1040mm X 442mm X 645mm

9. PRECAUTIONS

Please pay attention to the followings when you use this TFT LCD module.

9-1. MOUNTING PRECAUTIONS

- (1) You must mount a module using holes arranged in four corners or four sides.
- (2) You should consider the mounting structure so that uneven force (ex. Twisted stress) is not applied to the module. And the case on which a module is mounted should have sufficient strength so that external force is not transmitted directly to the module.
- (3) Please attach the surface transparent protective plate to the surface in order to protect the polarizer. Transparent protective plate should have sufficient strength in order to resist external force.
- (4) You should adopt radiation structure to satisfy the temperature specification.
- (5) Acetic acid type and chlorine type materials for the cover case are not desirable because the former generates corrosive gas of attacking the polarizer at high temperature and the latter causes circuit break by electro-chemical reaction.
- (6) Do not touch, push or rub the exposed polarizers with glass, tweezers or anything harder than HB pencil lead. And please do not rub with dust clothes with chemical treatment. Do not touch the surface of polarizer for bare hand or greasy cloth. (Some cosmetics are detrimental to the polarizer.)
- (7) When the surface becomes dusty, please wipe gently with absorbent cotton or other soft materials like chamois soaks with petroleum benzene. Normal-hexane is recommended for cleaning the adhesives used to attach front / rear polarizers. Do not use acetone, toluene and alcohol because they cause chemical damage to the polarizer.
- (8) Wipe off saliva or water drops as soon as possible. Their long time contact with polarizer causes deformations and color fading.
- (9) Do not open the case because inside circuits do not have sufficient strength.

9-2. OPERATING PRECAUTIONS

- (1) The spike noise causes the mis-operation of circuits. It should be lower than following voltage :
 $V = \pm 200\text{mV}$ (Over and under shoot voltage)
- (2) Response time depends on the temperature. (In lower temperature, it becomes longer.)
- (3) Brightness depends on the temperature. (In lower temperature, it becomes lower.)
And in lower temperature, response time (required time that brightness is stable after turned on) becomes longer.
- (4) Be careful for condensation at sudden temperature change. Condensation makes damage to polarizer or electrical contacted parts. And after fading condensation, smear or spot will occur.
- (5) When fixed patterns are displayed for a long time, remnant image is likely to occur.
- (6) Module has high frequency circuits. Sufficient suppression to the electromagnetic interference shall be done by system manufacturers. Grounding and shielding methods may be important to minimize the interference.
- (7) Please do not give any mechanical and/or acoustical impact to LCM. Otherwise, LCM can't be operated its full characteristics perfectly.
- (8) A screw which is fastened up the steels should be a machine screw.
(if not, it causes metallic foreign material and deal LCM a fatal blow)
- (9) Please do not set LCD on its edge.

9-3. ELECTROSTATIC DISCHARGE CONTROL

Since a module is composed of electronic circuits, it is not strong to electrostatic discharge. Make certain that treatment persons are connected to ground through wrist band etc. And don't touch interface pin directly.

9-4. PRECAUTIONS FOR STRONG LIGHT EXPOSURE

Strong light exposure causes degradation of polarizer and color filter.

9-5. STORAGE

When storing modules as spares for a long time, the following precautions are necessary.

- (1) Store them in a dark place. Do not expose the module to sunlight or fluorescent light. Keep the temperature between 5°C and 35°C at normal humidity.
- (2) The polarizer surface should not come in contact with any other object.
It is recommended that they be stored in the container in which they were shipped.

9-6. HANDLING PRECAUTIONS FOR PROTECTION FILM

- (1) The protection film is attached to the bezel with a small masking tape.
When the protection film is peeled off, static electricity is generated between the film and polarizer.
This should be peeled off slowly and carefully by people who are electrically grounded and with well ion-blown equipment or in such a condition, etc.
- (2) When the module with protection film attached is stored for a long time, sometimes there remains a very small amount of glue still on the bezel after the protection film is peeled off.
- (3) You can remove the glue easily. When the glue remains on the bezel surface or its vestige is recognized, please wipe them off with absorbent cotton waste or other soft material like chamois soaked with normal-hexane.