



Document Version: 6
Date: 2004/7/5

Product Functional Specification

17 inch WXGA+ Color TFT LCD Module
Model Name: B170PW02 V.0

(◆) Preliminary Specification
() Final Specification

Note: This Specification is subject to change without notice.

Contents

1.0 Handling Precautions	4
2.0 General Description	5
2.1 Display Characteristics	5
2.2 Functional Block Diagram.....	6
3.0 Absolute Maximum Ratings.....	7
4.0 Optical Characteristics.....	8
5.0 Signal Interface	12
5.1 Connectors	12
5.2 Signal Pin.....	12
5.3 Signal Description	14
5.4 Signal Electrical Characteristics	15
5.5 Signal for Lamp connector	15
6.0 Pixel Format Image.....	16
7.0 Parameter guide line for CCFL Inverter.....	16
8.0 Interface Timings	17
8.1 Timing Characteristics.....	17
8.2 Timing Definition	18
9.0 Power Consumption.....	19
10. Power ON/OFF Sequence.....	20
11.0 Reliability /Safety Requirement.....	21
11.1 Reliability Test Conditions	21
11.2 Safety	21
12.0 Packing dimension	22
13.0 Mechanical Characteristics.....	23
13.1 LCM Outline dimension (Front View)	23
13.2 LCM Outline Dimension (Rear View)	24
13.3 Screw Hole Depth and Center Position	25
14. Shipping Label Format.....	26

II Record of Revision

Version and Date	Page	Old description	New Description	Remark
V1. 2004/3/3	All	First Release	NA	
V2. 2004/3/10	17	NA	Add note 6	Update
V3. 2004/3/23	17	Clock frequency and Horizontal Section	Clock frequency and Horizontal Section	Update
V4. 2004/5/13	16	CCFL DP-1	CCFL DP-1	Update
	17	Timing Characteristics	Timing Characteristics	Update
	18	Timing Definition	Timing Definition	Update
	19	Power Consumption	Power Consumption	Update
	24	LCM drawing (Rear View)	LCM drawing (Rear View)	Update
V5. 2004/6/29	23	LCM drawing (Front View)	LCM drawing (Front View)	Update
V.6 2004/7/5	8	N/A	Add viewing angle min value	Add

1.0 Handling Precautions

- 1) Do not press or scratch the surface harder than a HB pencil lead because the polarizers are very fragile and could be easily damaged.
- 2) Be sure to turn off power supply when inserting or disconnecting from input connector.
- 3) Wipe off water droplets or oil immediately. Long contact with the droplets may cause discoloration or spots.
- 4) When the panel surface is soiled, wipe it with absorbent cotton or other soft cloth.
- 5) Since the panel is made of glass, it may break or crack if dropped or bumped on hard surface.
- 6) Protect the module from static electricity and insure proper grounding when handling. Static electricity may cause damage to the CMOS Gate Array IC.
- 7) Do not disassemble the module.
- 8) Do not press the reflector sheet at the back of the module.
- 9) Avoid damaging the TFT module. Do not press the center of the CCFL Reflector when it was taken out from the packing container. Instead, press at the edge of the CCFL Reflector softly.
- 10) Do not rotate or tilt the signal interface connector of the TFT module when you insert or remove other connector into the signal interface connector.
- 11) Do not twist or bend the TFT module when installation of the TFT module into an enclosure (Notebook PC Bezel, for example). It should be taken into consideration that no bending/twisting forces are applied to the TFT module from outside when designing the enclosure. Otherwise the TFT module may be damaged.
- 12) Cold cathode fluorescent lamp in LCD contains a small amount of mercury. Please follow local regulations for disposal.
- 13) The LCD module contains a small amount of material that has no flammability grade, so it should be supplied by power complied with requirements of limited power source (2.11, IEC60950 or UL1950).
- 14) The CCFL in the LCD module is supplied with Limited Current Circuit (2.4, IEC60950 or UL 60950). Do not connect the CCFL in Hazardous Voltage Circuit.

2.0 General Description

This specification applies to the 17 inch Color TFT/LCD Module B170PW02

This module is designed for a display unit of notebook style personal computer.

The screen format is intended to support the WXGA +(1440(H) x 900(V)) screen and 262k colors (RGB 6-bits data driver).

All input signals are LVDS interface compatible.

This module does not contain an inverter card for backlight.

2.1 Display Characteristics

The following items are characteristics summary on the table under 25 condition:

ITEMS	Unit	SPECIFICATIONS
Screen Diagonal	[mm]	17.0"
Active Area	[mm]	367.20(H) x 229.50(V)
Pixels H x V		1440 (x3) x 900
Pixel Pitch	[mm]	0..255(per one triad) x 0.255
Pixel Arrangement		R.G.B. Vertical Stripe
Display Mode		Normally White
Typical White Luminance(CCFL=6.0mA)	[cd/m ²]	385 Typ.(5 points average)
Contrast Ratio		350 : 1 Min ,400:1 Typ
Response Time	[msec]	16 Typ.
Nominal Input Voltage VDD	[Volt]	+3.3 Typ.
Typical Power Consumption (VDD line + VCFL line)	[Watt]	13 Watt (w/o Inverter, All black pattern)@LCM circuit 3.3 Watt(typ.),B/L input 9.8 Watt (typ.)
Weight	[Grams]	1100g max. (w/o Inverter)
Physical Size	[mm]	382.2(W) x 246.8(H) x 10.0(upper) max. /8.6(lower) max
Electrical Interface		2 channel LVDS (4pair/1 channel)
Surface treatment		Glare, low reflection
Support Color		Native 262K colors (RGB 6-bit data driver)
Temperature Range		
Operating	[°C]	0 to +50
Storage (Shipping)	[°C]	-20 to +60

2.2 Functional Block Diagram

The following diagram shows the functional block of the 17 inches Color TFT/LCD Module:

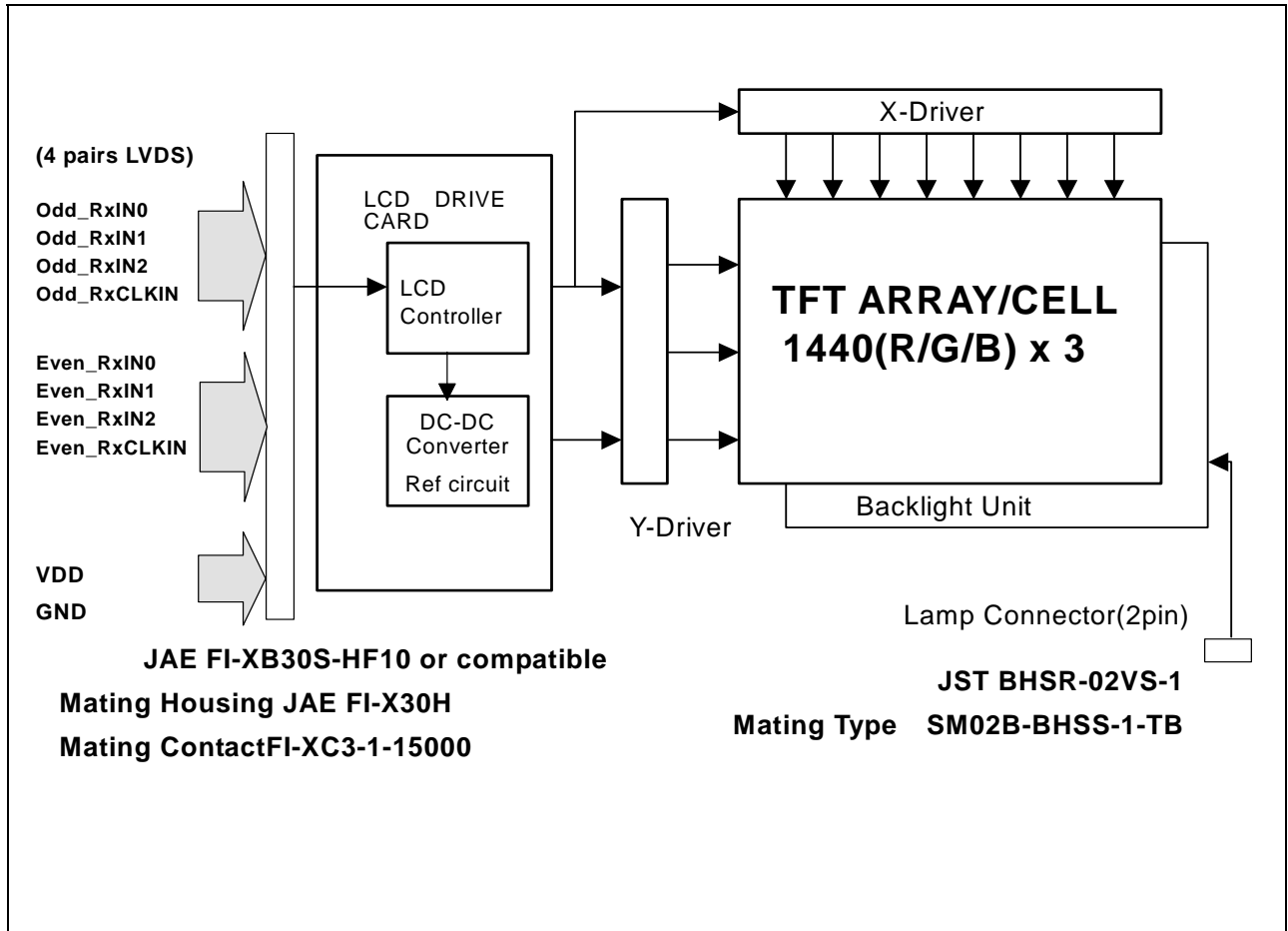

3.0 Absolute Maximum Ratings

Absolute maximum ratings of the module is as following:

Item	Symbol	Min	Max	Unit	Conditions
Logic/LCD Drive Voltage	VDD	-0.3	+4.0	[Volt]	
Input Voltage of Signal	Vin	-0.3	VDD+0.3	[Volt]	
CCFL Current	ICFL	-	7	[mA] rms	
CCFL Ignition Voltage	Vs	-	1160(25°C)	Vrms	Note 1
Operating Temperature	TOP	0	+50	[°C]	Note 2
Operating Humidity	HOP	5	95	[%RH]	Note 2
Storage Temperature	TST	-20	+60	[°C]	Note 2
Storage Humidity	HST	5	95	[%RH]	Note 2
Vibration			1.5 10-500	[G Hz]	
Shock			180 , 2	[G ms]	Half sine wave

Note 1 : Duration = 50msec

Note 2 : Maximum Wet-Bulb should be 39 and No condensation.

Wet bulb temperature chart

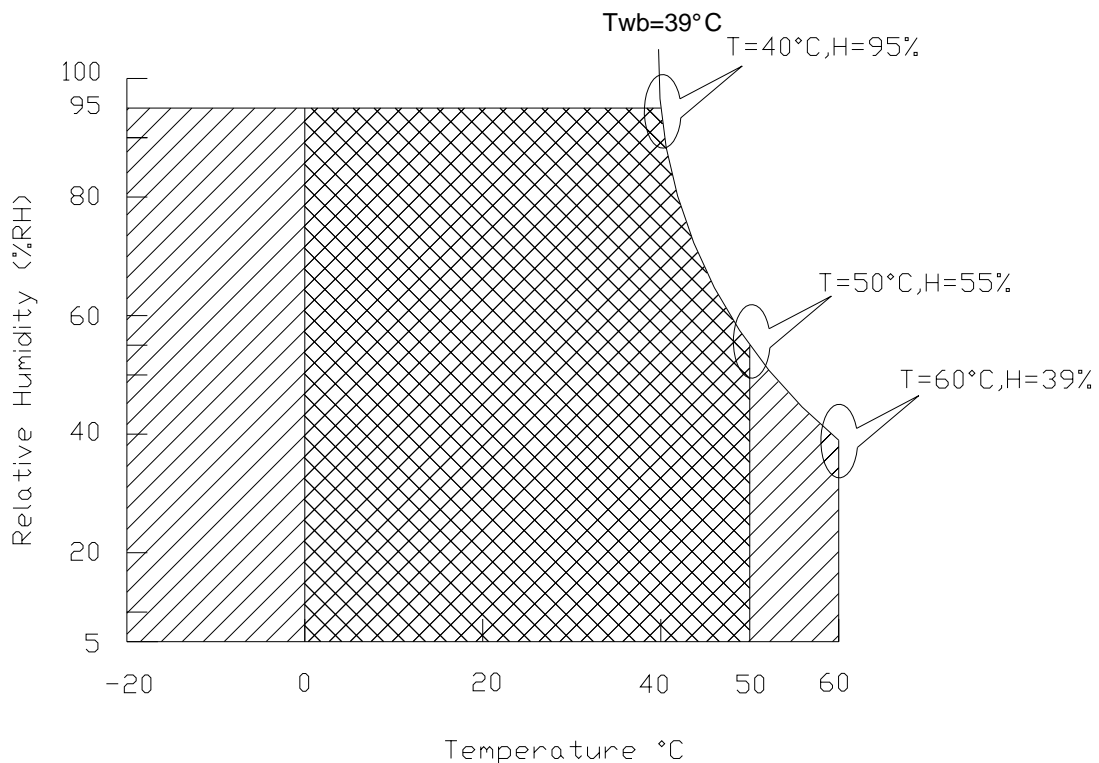

Operating Range

Storage Range +

(C) Copyright AU Optronics

Sep., 2003 All Rights Reserved.

B170PW02 V0 Spec Ver.6

No Reproduction and Redistribution Allowed.

4.0 Optical Characteristics

The optical characteristics are measured under stable conditions as follows under 25 condition:

Item	Unit	Conditions	Min.	Typ.	Max.	Note
White Luminance CCFL 6.0mA	[cd/m ²]	5 points average	355	385	-	1,2,3
Viewing Angle	[degree]	Horizontal (Right)	60	70	-	2,7
	[degree]	CR = 10 (Left)	60	70	-	
	[degree]	Vertical (Upper)	50	60	-	
	[degree]	CR = 10 (Lower)	50	60	-	
Uniformity		5 Points			1.2	1
Uniformity		13 Points			1.5	
CR: Contrast Ratio			350	400	-	6
Cross talk	%				4	4
Response Time	[msec]	Rising	-	12	17	5
	[msec]	Falling	-	4	8	
	[msec]	Raising + Falling		16	25	
Color / Chromaticity Coordinates (CIE 1931)		Red x	0.580	0.610	0.640	2,7
		Red y	0.310	0.340	0.370	
		Green x	0.285	0.315	0.345	
		Green y	0.520	0.550	0.580	
		Blue x	0.115	0.145	0.175	
		Blue y	0.085	0.115	0.145	
		White x	0.290	0.320	0.350	
		White y	0.300	0.330	0.360	

Note 1: Definition of 5 ,13 points position & white uniformity:

White uniformity is defined as the following with five/thirteen measurements (1~13).

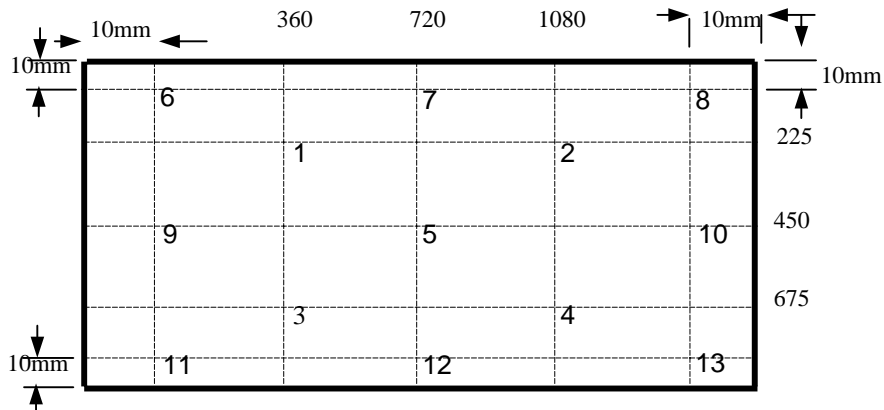

Maximum Brightness of five (1,2,3,4,5) points

$w_5 = \frac{\text{Maximum Brightness of five (1,2,3,4,5) points}}{\text{Minimum Brightness of five (1,2,3,4,5) points}}$

Maximum Brightness of thirteen points

$w_{13} = \frac{\text{Maximum Brightness of thirteen points}}{\text{Minimum Brightness of thirteen points}}$

Note 2: Measurement method

The LCD module should be stabilized at given temperature for 30 minutes to avoid abrupt temperature change during measuring. In order to stabilize the luminance, the measurement should be executed after lighting Backlight for 30 minutes in a stable, windless and dark room.

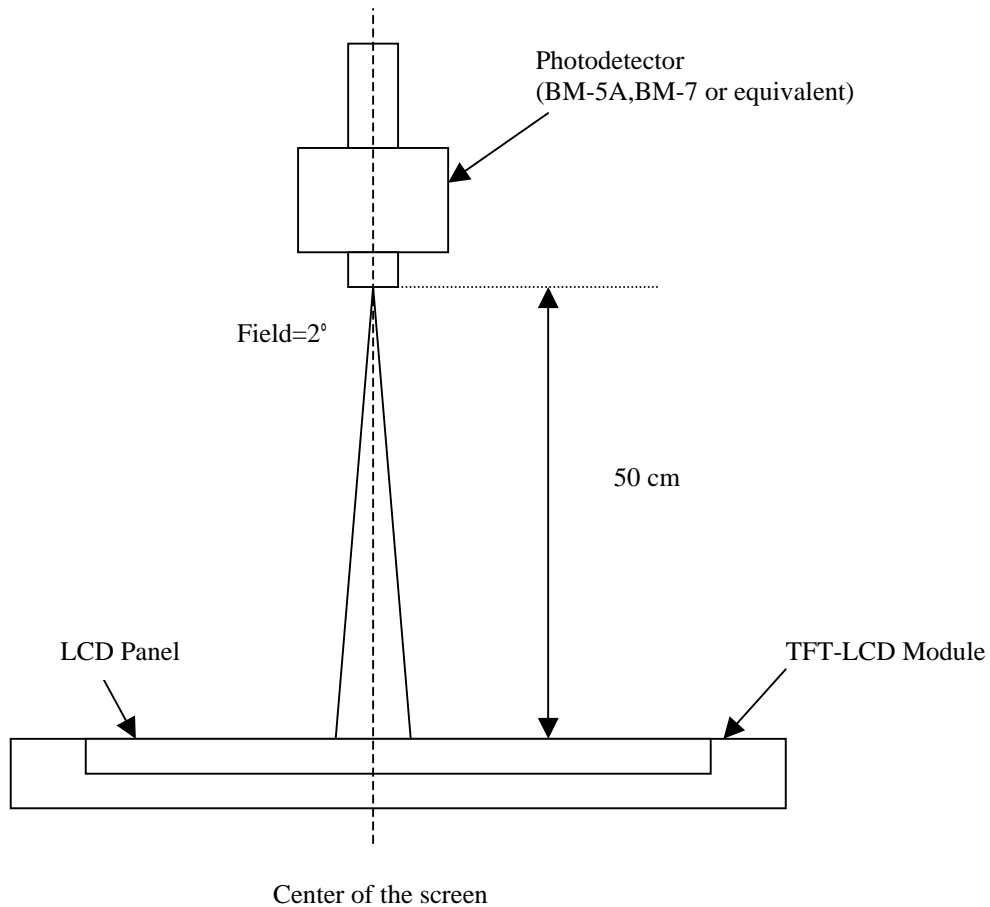

Note 3: Definition of Average Luminance of White (Y_L):

Measure the luminance of gray level 63 at 5 points , $Y_L = [L (1)+ L (2)+ L (3)+ L (4)+ L (5)] / 5$
 $L (x)$ is corresponding to the luminance of the point X at Figure in Note (1).

Note 4 : Definition of Cross Talk (CT)

$$CT = | Y_B - Y_A | / Y_A \times 100 (\%)$$

Where

Y_A = Luminance of measured location without gray level 0 pattern (cd/m²)

Y_B = Luminance of measured location with gray level 0 pattern (cd/m²)

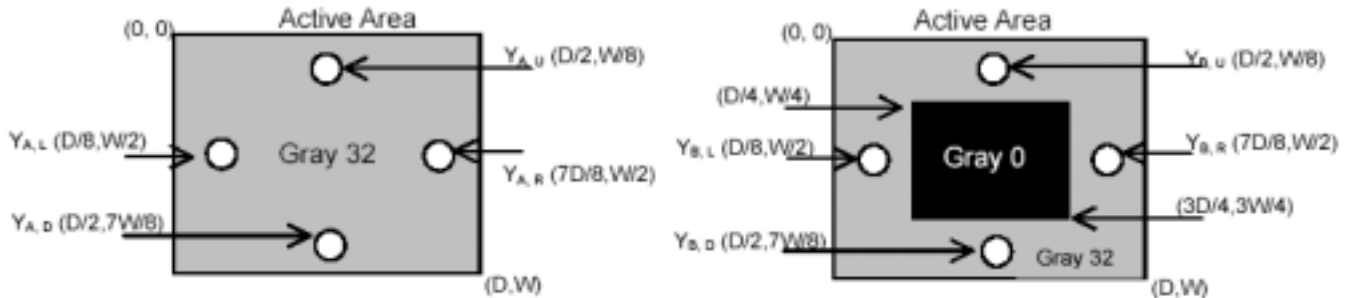

Note 5: Definition of response time:

The output signals of BM-7 or equivalent are measured when the input signals are changed from "Black" to "White" (falling time) and from "White" to "Black" (rising time), respectively. The response time interval between the 10% and 90% of amplitudes. Refer to figure as below.

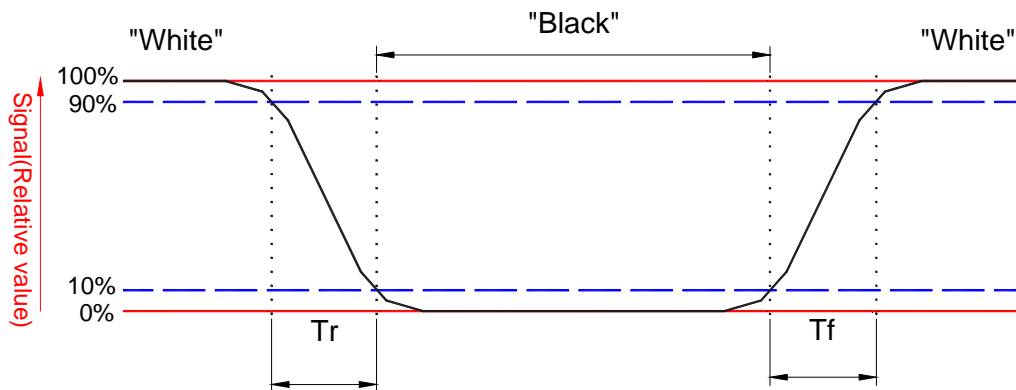

Note 6. Definition of contrast ratio:

Contrast ratio is calculated with the following formula.

$$\text{Contrast ratio (CR)} = \frac{\text{Brightness on the "White" state}}{\text{Brightness on the "Black" state}}$$

Note 7. Definition of viewing angle

Viewing angle is the measurement of contrast ratio ≥ 10 , at the screen center, over a 180° horizontal and 180° vertical range (off-normal viewing angles). The 180° viewing angle range is broken down as follows; 90° () horizontal left and right and 90° () vertical, high (up) and low (down). The measurement direction is typically perpendicular to the display surface with the screen rotated about its center to develop the desired measurement viewing angle.

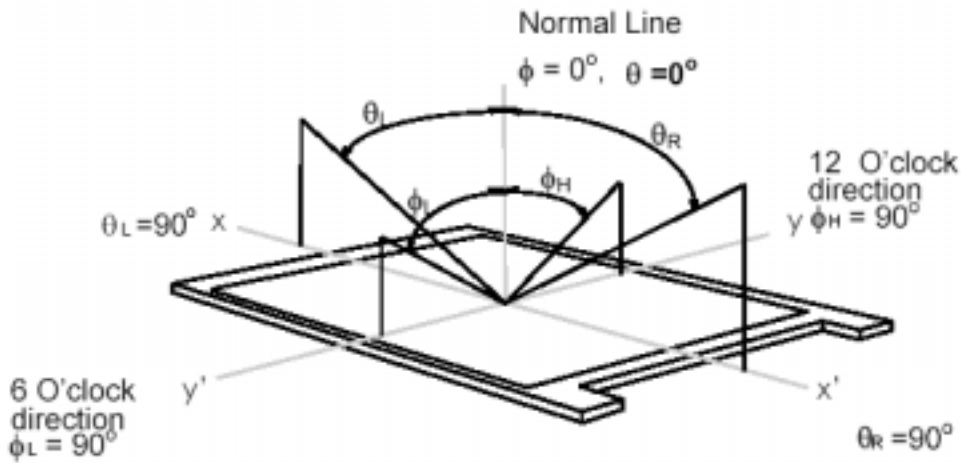

5.0 Signal Interface

5.1 Connectors

Physical interface is described as for the connector on module.

These connectors are capable of accommodating the following signals and will be following components.

Connector Name / Designation	For Signal Connector
Manufacturer	JAE or compatible
Type / Part Number	FI-XB30S-HF10 or compatible
Mating Housing/Part Number	FI-X30H
Mating Contact/Part Number	FI-XC3-1-15000

Connector Name / Designation	For Lamp Connector
Manufacturer	JST
Type / Part Number	BHSR-02VS-1
Mating Type / Part Number	SM02B-BHSS-1-TB

5.2 Signal Pin

(1).Input signal interface

Pin no	Symbol	Function	Etc.
1	GND	Ground	
2	VDD	Power supply ,3.3 V (typical)	
3	VDD	Power supply ,3.3 V (typical)	
4	V _{EDID}	DDC 3.3V power	
5	NC	Reserved for supplier test	
6	CLK _{EDID}	DDC Clock	
7	Data _{EDID}	DDC data	
8	Odd_RxIN0-	-LVDS differential data input	
9	Odd_RxIN0+	+LVDS differential data input	
10	GND	Ground	
11	Odd_RxIN1-	-LVDS differential data input	
12	Odd_RxIN1+	+LVDS differential data input	
13	GND	Ground	
14	Odd_RxIN2-	-LVDS differential data input	
15	Odd_RxIN2+	+LVDS differential data input	

(C) Copyright AU Optronics

Sep., 2003 All Rights Reserved.

B170PW02 V0 Spec Ver.6

No Reproduction and Redistribution Allowed.

12/12

16	GND	Ground	
17	Odd_RxCLKIN-	-LVDS differential clock input	
18	Odd_RxCLKIN+	+LVDS differential clock input	
19	GND	Ground	
20	Even_RxIN0-	-LVDS differential data input	
21	Even_RxIN0+	+LVDS differential data input	
22	GND	Ground	
23	Even_RxIN1-	-LVDS differential data input	
24	Even_RxIN1+	+LVDS differential data input	
25	GND	Ground	
26	Even_RxIN2-	-LVDS differential data input	
27	Even_RxIN2+	+LVDS differential data input	
28	GND	Ground	
29	Even_RxCLKIN-	-LVDS differential clock input	
30	Even_RxCLKIN+	+LVDS differential clock input	

(2) LVDS channel interface data mapping diagram

ODD pair(1st pixel input)

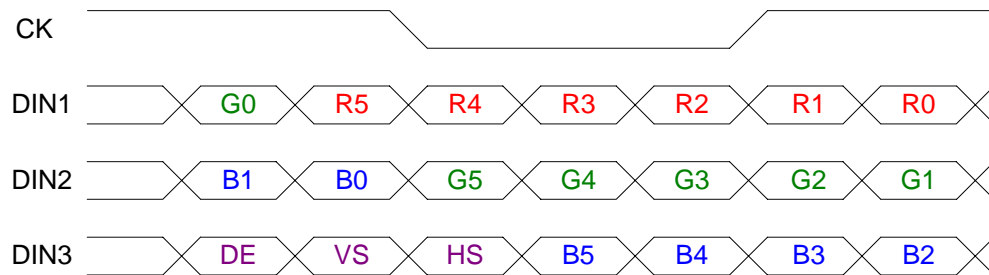

Even pair(2nd pixel input)

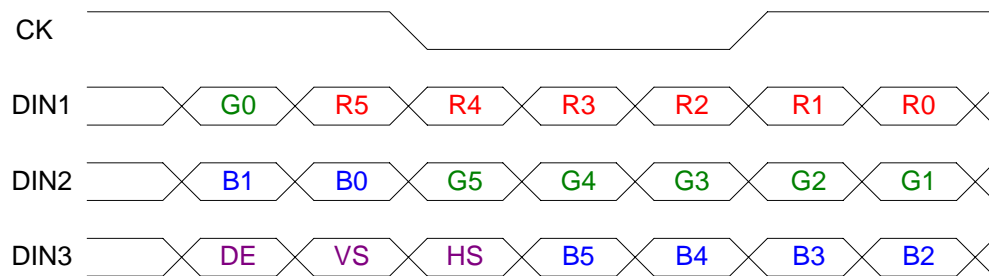

5.3 Signal Description

The module uses a LVDS receiver embedded in AUO's ASIC. LVDS is a differential signal technology for LCD interface and high-speed data transfer device.

Signal Name	Description
V _{EDID}	+3.3V EDID Power
CLK _{EDID}	EDID Clock Input
DATA _{EDID}	EDID Data Input
Odd_RxIN0-, Odd_RxIN0+ Even_RxIN0-, Even_RxIN0+	LVDS differential data input (Red0-Red5, Green0)
Odd_RxIN1-, Odd_RxIN1+ Even_RxIN1-, Even_RxIN1+	LVDS differential data input (Green1-Green5, Blue0-Blue1)
Odd_RxIN2-, Odd_RxIN2+ Even_RxIN2-, Even_RxIN2+	LVDS differential data input (Blue2-Blue5, Hsync, Vsync, DSPTMG)
Odd_RxCLKIN, Odd_RxCLKIN0+ Even_RxCLKIN-, Even_RxCLKIN0+	LVDS differential clock input
VDD	+3.3V Power Supply
GND	Ground

Note: Input signals shall be in low status when VDD is off.

Internal circuit of LVDS inputs are as following.

Signal Name	Description	
+RED5 +RED4 +RED3 +RED2 +RED1 +RED0	Red Data 5 (MSB) Red Data 4 Red Data 3 Red Data 2 Red Data 1 Red Data 0 (LSB) Red-pixel Data	Red-pixel Data Each red pixel's brightness data consists of these 6 bits pixel data.
+GREEN 5 +GREEN 4 +GREEN 3 +GREEN 2 +GREEN 1 +GREEN 0	Green Data 5 (MSB) Green Data 4 Green Data 3 Green Data 2 Green Data 1 Green Data 0 (LSB) Green-pixel Data	Green-pixel Data Each green pixel's brightness data consists of these 6 bits pixel data.
+BLUE 5 +BLUE 4 +BLUE 3 +BLUE 2 +BLUE 1 +BLUE 0	Blue Data 5 (MSB) Blue Data 4 Blue Data 3 Blue Data 2 Blue Data 1 Blue Data 0 (LSB) Blue-pixel Data	Blue-pixel Data Each blue pixel's brightness data consists of these 6 bits pixel data.
-DTCLK	Data Clock	The typical frequency is 48.2 MHz. The signal is used to strobe the pixel data and DSPTMG signals. All pixel data shall be valid at the falling edge when the DSPTMG signal is high.
DSPTMG	Display Timing	This signal is strobed at the falling edge of -DTCLK. When the signal is high, the pixel data shall be valid to be displayed.
VSYNC	Vertical Sync	The signal is synchronized to -DTCLK .
HSYNC	Horizontal Sync	The signal is synchronized to -DTCLK .

Note: Output signals from any system shall be low or Hi-Z state when VDD is off.

5.4 Signal Electrical Characteristics

Input signals shall be in low status when VDD is off.

It is recommended to refer the specifications of SN75LVDS86DGG (Texas Instruments) in detail.

Signal electrical characteristics are as follows;

Parameter	Condition	Min	Max	Unit
Vth	Differential Input High Voltage(Vcm=+1.2V)		100	[mV]
Vtl	Differential Input Low Voltage(Vcm=+1.2V)	-100		[mV]

5.5 Signal for Lamp connector

Pin #	Signal Name
1	Lamp High Voltage
2	Lamp Low Voltage

6.0 Pixel Format Image

Following figure shows the relationship of the input signals and LCD pixel format.

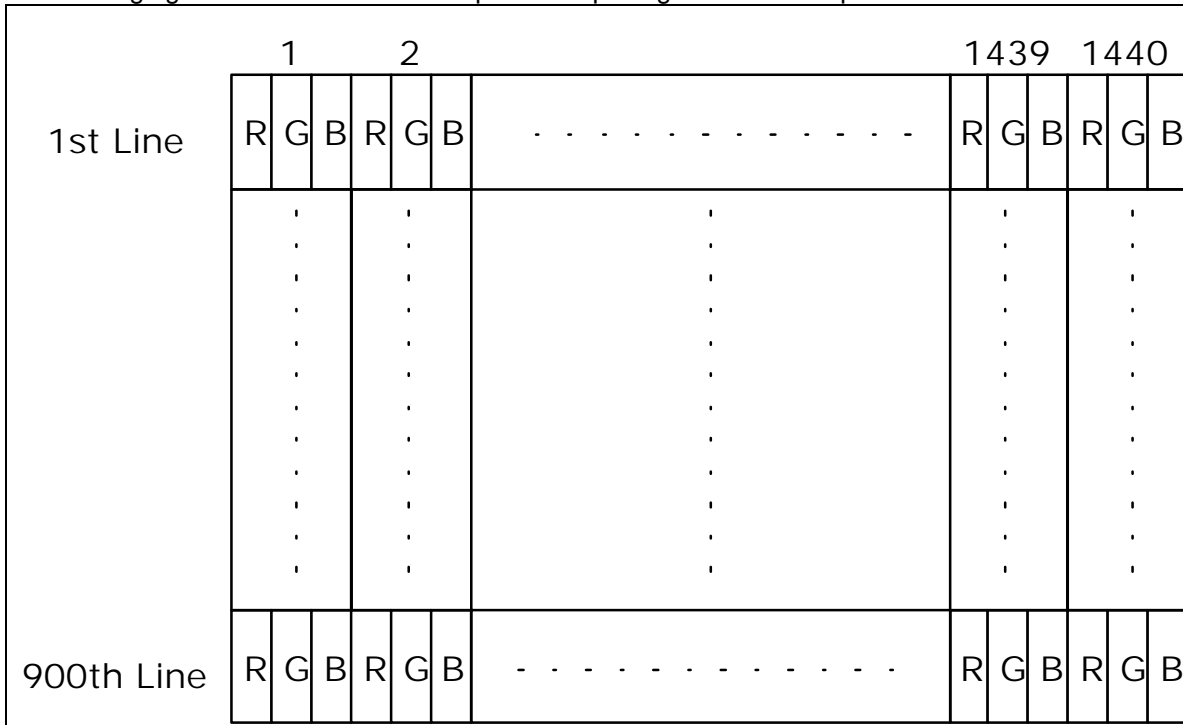

7.0 Parameter guide line for CCFL Inverter

Parameter	Min	DP-1	Max	Units	Condition
White Luminance 5 points average	350	385	—	[cd/m ²]	(Ta=25)
CCFL current(ICFL)		6.0	7.0	[mA] rms	(Ta=25) Note 2
CCFL Frequency(FCFL)	45	50	80	[KHz]	(Ta=25) Note 3
CCFL Ignition Voltage(Vs)		—	1500	[Volt] rms	(Ta= 0) Note 4
CCFL Voltage (Reference) (VCFL)	775	815	940	[Volt] rms	(Ta=25) Note 5
CCFL Power consumption (PCFL)	—	9.8	—	[Watt]	(Ta=25) Note 5, 6

Note 1: DP-1 are AUO recommended Design Points.

*1 All of characteristics listed are measured under the condition using the AUO Test inverter.

*2 In case of using an inverter other than listed, it is recommended to check the inverter carefully. Sometimes, interfering noise stripes appear on the screen, and substandard luminance or flicker at low power may happen.

*3 In designing an inverter, it is suggested to check safety circuit ver carefully. Impedance of CCFL, for instance, becomes more than 1 [M ohm] when CCFL is damaged.

*4 Generally, CCFL has some amount of delay time after applying start-up voltage. It is recommended to keep on applying start-up voltage for 1 [Sec] until discharge.

*5 The CCFL inverter operating frequency must be carefully chosen so that no interfering noise stripes on the screen were induced.

*6 Reducing CCFL current increases CCFL discharge voltage and generally increases CCFL discharge frequency. So all the parameters of an inverter should be carefully designed so as not to produce too much leakage current from high-voltage output of the inverter.

Note 2: It should be employed the inverter, which has "Duty Dimming", if ICCFL is less than 4mA.

Note 3: The CCFL inverter operating frequency should be carefully determined to avoid interference between inverter and TFT LCD.

Note 4: The inverter open voltage should be designed larger than the lamp starting voltage at T=0°C, otherwise backlight may be blinking for a moment after turning on or not be able to turn on. The open voltage should be measured after ballast capacitor. If an inverter has shutdown function it should keep its open voltage. for longer than 1 second even if lamp connector is open.

Note 5: Calculator value for reference (ICFL×VCFL=PCFL)

Note 6: This model has 2 CCFL lamps.

8.0 Interface Timings

8.1 Timing Characteristics

Parameter		Symbol	Min.	Typ.	Max.	Unit	Condition
Clock frequency		$1/T_{\text{CLOCK}}$	20	48.2	85	MHz	LVDS 2 channel input
Horizontal Section	Period	T_H	-	880	-	T_{CLOCK}	
	Active	T_{HD}	720	720	720		
	Blanking	T_{HB}	-	160	-		
	Hsync Width	T_{HSW}	-	16	-		
	Back Porch	T_{HSB}	-	112	-		
	Front Porch	T_{HSF}	-	32	-		
Vertical Section	Period	T_V	-	912	-	T_{HD}	
	Active	T_{VD}	900	900	900		
	Blanking	T_{VB}	-	12	-		
	Vsync Width	T_{VSW}	-	3	-		
	Back Porch	T_{VSB}	-	6	-		
	Front Porch	T_{VSF}	-	3	-		

8.2 Timing Definition

Input Timing Definition

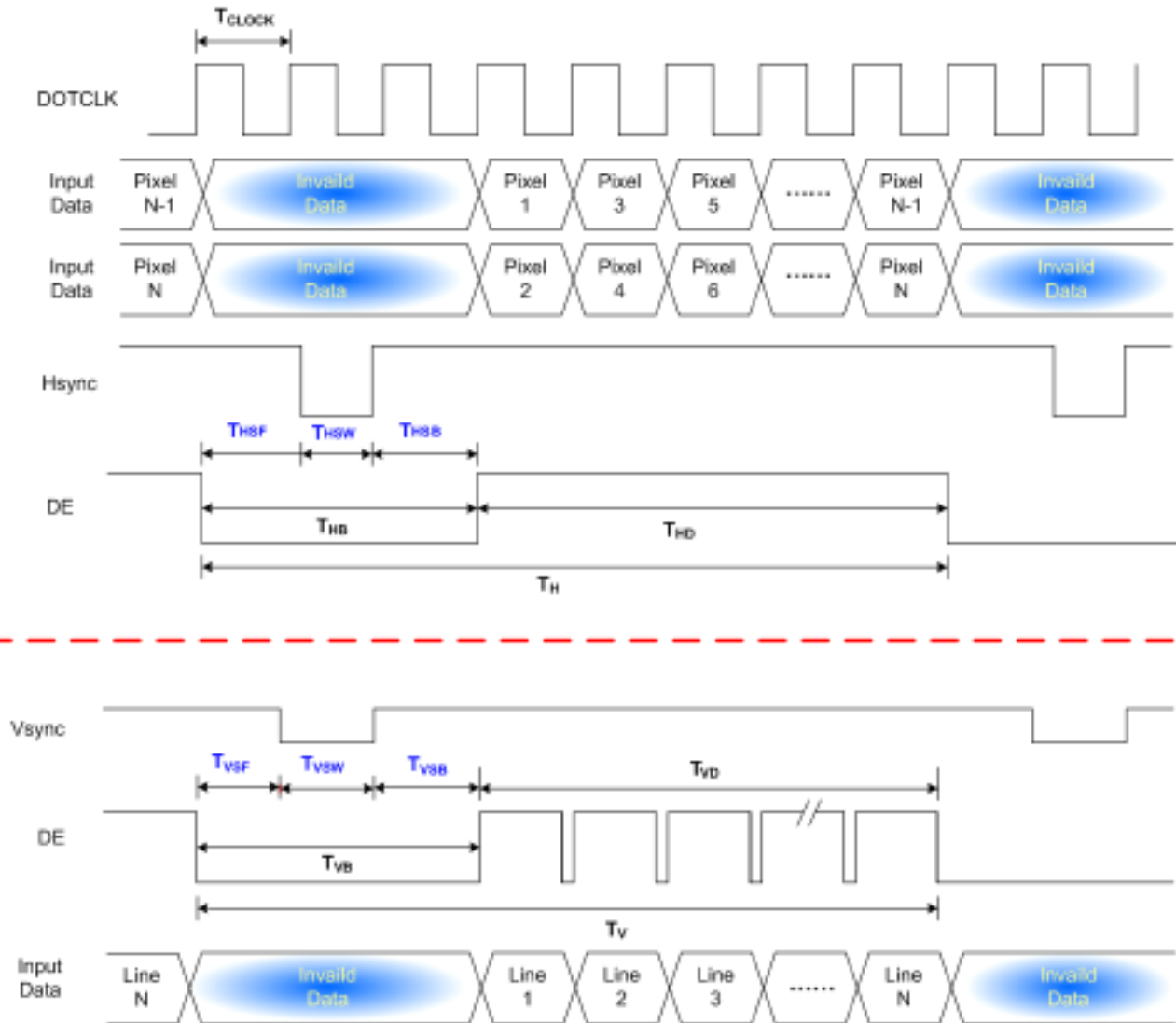

9.0 Power Consumption

Input power specifications are as follows;

Symbol	Parameter	Min	Typ	Max	Units	Condition
Module						
VDD	Logic/LCD Drive Voltage	3.0	3.3	3.6	[Volt]	Load Capacitance 20uF
PDD	VDD Power		2.15		[Watt]	All White pattern
PDD Max	VDD Power max			3.3	[Watt]	All BLACK pattern
IDD	IDD Current		630		mA	All White pattern
IDD Max	IDD Current max			1000	mA	All BLACK pattern
VDDrp	Allowable Logic/LCD Drive Ripple Voltage			100	[mV] p-p	
VDDns	Allowable Logic/LCD Drive Ripple Noise			100	[mV] p-p	
Lamp						
ICFL	CCFL current	3.0	6.0	7.0	[mA] rms	(Ta=25)
VCFL	CCFL Voltage (Reference)	—	785	—	[Volt] rms	(Ta=25)
PCFL	CCFL Power consumption	—	9.8	—	[Watt]	(Ta=25)
Total Power Consumption	13.1 Watt typ (w/o Inverter, All black pattern)@LCM circuit 3.3 Watt(typ.),B/L input 9.8 Watt(typ.)					

Note : VDD=3.3V

10. Power ON/OFF Sequence

VDD power and lamp on/off sequence is as follows. Interface signals are also shown in the chart. Signals from any system shall be Hi-Z state or low level when VDD is off.

Sequence of Power-on/off and signal-on/off

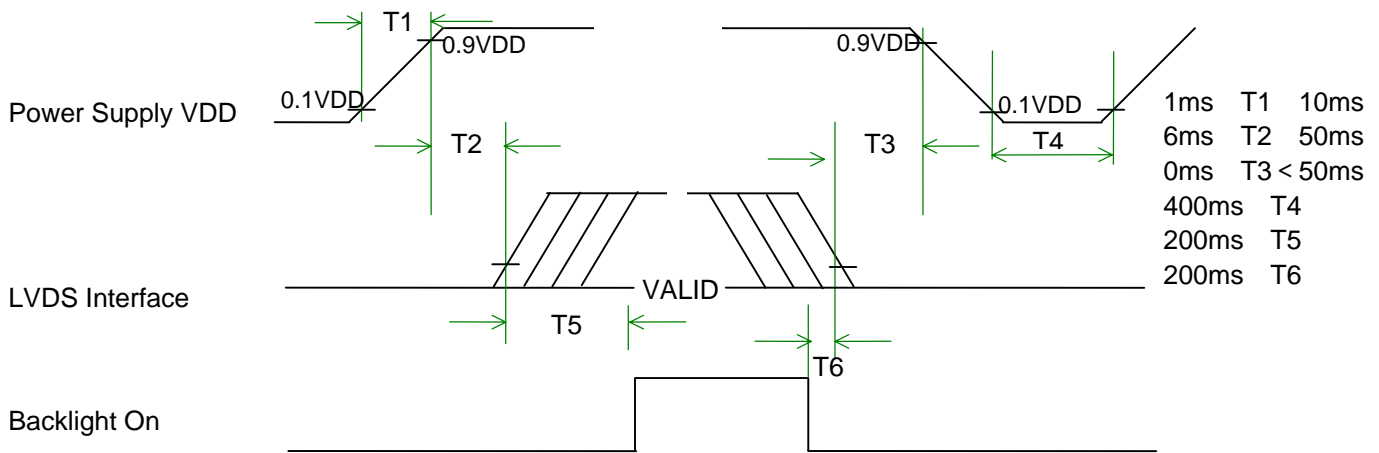

Apply the lamp voltage within the LCD operating range. When the backlight turns on before the LCD operation or the LCD turns off before the backlight turns off, the display may momentarily become abnormal.

11.0 Reliability /Safety Requirement

11.1 Reliability Test Conditions

Items	Required Condition
Temperature Humidity Bias	40 /90%,300Hr
High Temperature Operation	50 /Dry,300Hr
Low Temperature Operation	0 ,500Hr
Continuous Life	25 ,2000 hours
On/Off Test	ON/30 sec. OFF/30sec., 30,000 cycles
Hot Storage	60 /40% RH ,240 hours
Cold Storage	-20 /50% RH ,240 hours
Thermal Shock Test	-20 /30 min ,60 /30 min 100cycles
Hot Start Test	50 /1 Hr min. power on/off per 5 minutes, 5 times
Cold Start Test	0 /1 Hr min. power on/off per 5 minutes, 5 times
Shock Test (Non-Operating)	180G, 2ms, Half-sine wave
Vibration Test (Non-Operating)	Sinusoidal vibration, 1.5G zero-to-peak, 10 to 500 Hz, 0.5 octave/minute; 0.5hr in each of three mutually perpendicular axes.
ESD	Contact : operation ±8KV / non-operation ±10KV Air : operation ±15KV / non-operation ±20KV
Altitude Test	10000 ft / operation / 8Hr 30000ft / non-operation / 24r
Maximum Side Mount Torque	2.5kgf.cm .

CCFL Life : 10,000 hours minimum

MTBF(Excluding the CCFL) : 30,000 hours with a confidence level 90%

11.2 Safety

UL 60950

12.0 Packing dimension

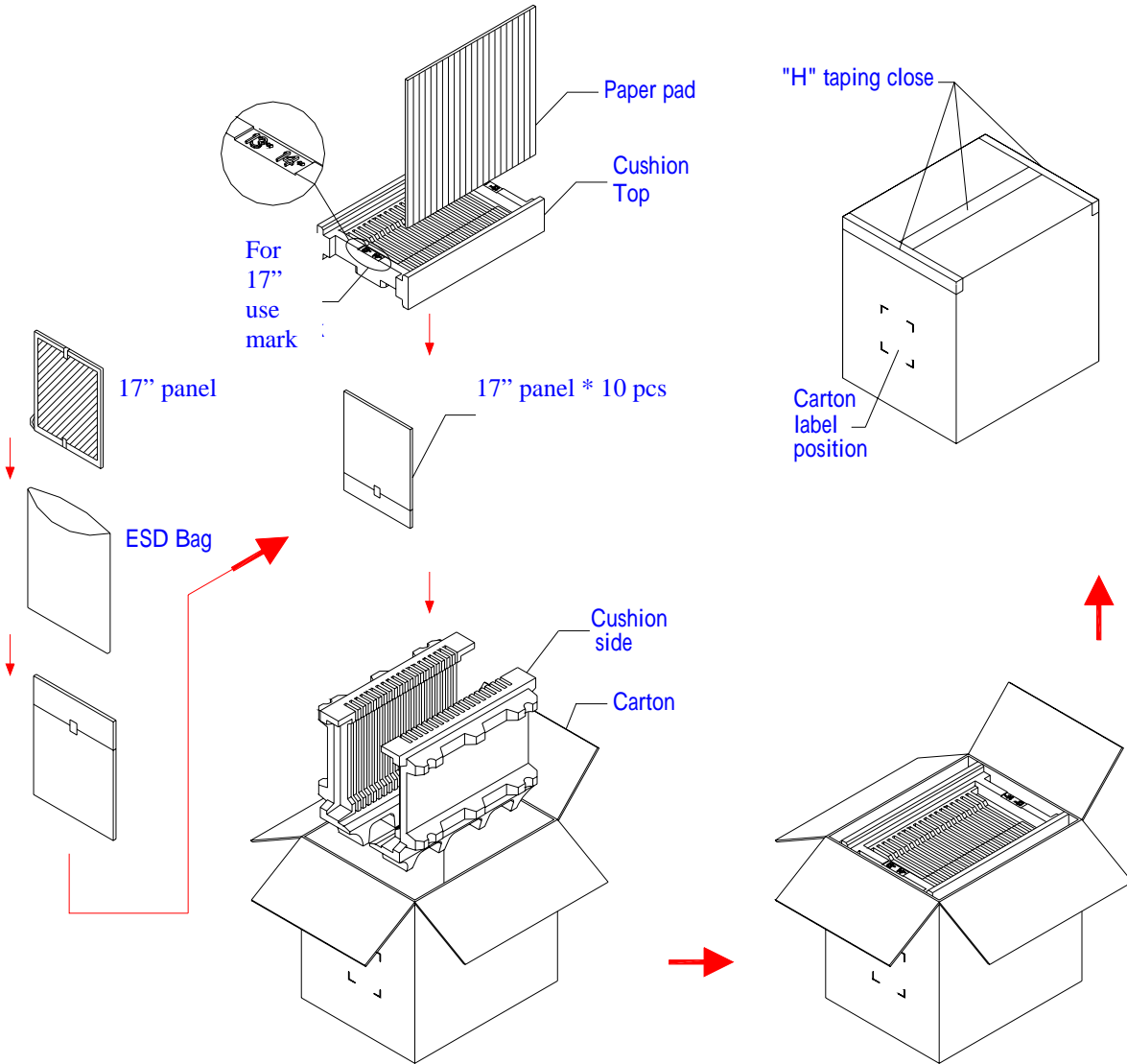

13.2 LCM Outline Dimension (Rear View)

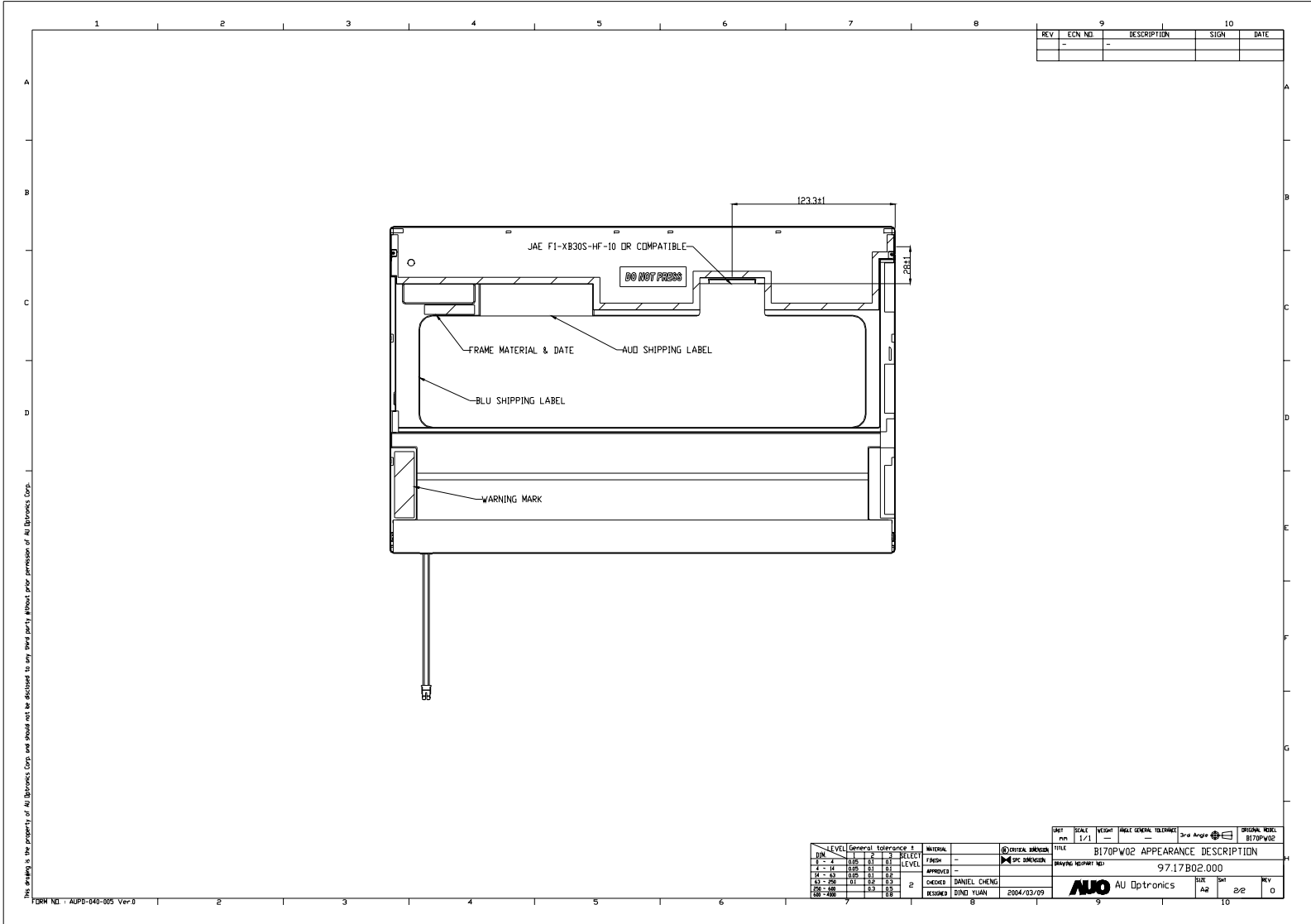

(C) Copyright AU Optonics
 Sep., 2003 All Rights Reserved.

B170PW02 V0 Spec Ver.6

No Reproduction and Redistribution Allowed.

13.3 Screw Hole Depth and Center Position

- Screw hole minimum depth, from side surface = 2.5 mm (See drawing)
- Screw hole center location, from front surface = 4.2 ± 0.3 mm (See drawing)
- Screw maximum length = 2.3 mm (See drawing)
- Screw Torque: Maximum 2.5 kgf-cm

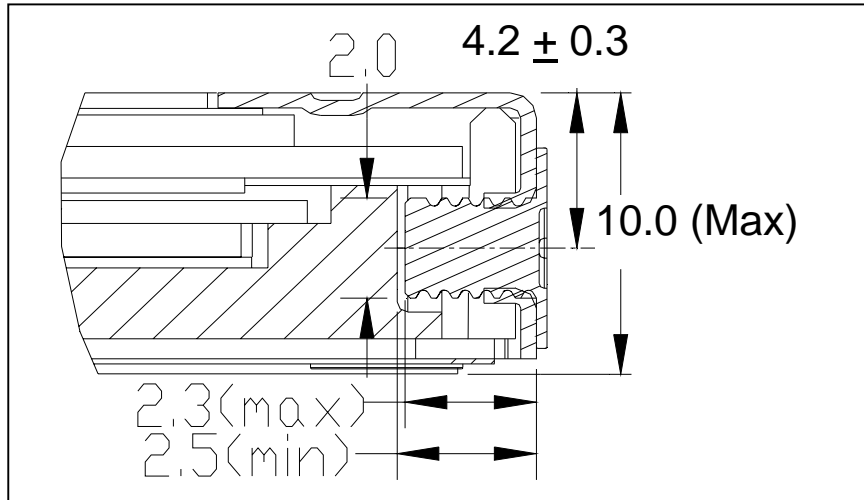

14. Shipping Label Format

