



TFT COLOR LCD MODULE

NL10276BC30-10

38cm (15.0 Type)

XGA

LVDS Interface (1port)

PRELIMINARY DATA SHEET 

(3rd edition)

**All information is subject to change without notice.
Please confirm the delivery specification before starting
to design your system.**

INTRODUCTION

No part of this document shall be copied in any form or by any means without the prior written consent of NEC Corporation.

NEC Corporation does not assume any liability for infringement of patents, copyrights or other intellectual property rights of third parties by or arising from use of a product described herein or any other liability arising from use of such application. No license, express, implied or otherwise, is granted under any patents, copyrights or other intellectual property rights of NEC Corporation or of others.

While NEC Corporation has been making continuous effort to enhance the reliability of its products, the possibility of failures cannot be eliminated entirely. To minimize risks of damage to property or injury to person arising from a failure in an NEC product, customers must incorporate sufficient safety measures in their design, such as redundancy, fire-containment and anti-failure features.

NEC products are classified into the following three quality grades:

"Standard", "Special", "Specific"

The *"Specific"* quality grade applies only to applications developed based on a customer designated "quality assurance program" for a specific application. The recommended applications of a product depend on its quality grade, as indicated below. Customers must check the quality grade of each application before using it in a particular application.

Standard: Computers, office equipment, communications equipment, test and measurement equipment, audio and visual equipment, home electronic appliances, machine tools, personal electronic equipment and industrial robots

Special: Transportation equipment (automobiles, trains, ships, etc.), traffic control systems, anti-disaster systems, anti-crime systems, safety equipment and medical equipment (not specifically designed for life support)

Specific: Military systems, aircraft, aerospace equipment, submersible repeaters, nuclear reactor control systems, life support systems (medical equipment, etc.) and any other equipment

The quality grade of this product is *"Standard"* unless otherwise specified in this document. If customers intend to use this product for applications other than those specified for *"Standard"* quality grade, they should contact NEC Corporation sales representative in advance.

Anti-radioactive design is not implemented in this product.

CONTENTS

INTRODUCTION..... 2

1. OUTLINE 4

 1.1 STRUCTURE AND PRINCIPLE 4

 1.2 APPLICATIONS 4

 1.3 FEATURES 4

2. GENERAL SPECIFICATIONS..... 5

3. BLOCK DIAGRAM 6

4. DETAILED SPECIFICATIONS..... 7

 4.1 MECHANICAL SPECIFICATIONS 7

 4.2 ABSOLUTE MAXIMUM RATINGS 7

 4.3 ELECTRICAL CHARACTERISTICS 8

 4.3.1 Driving for LCD panel signal processing board 8

 4.3.2 Driving for backlight lamp 9

 4.3.3 Power supply voltage ripple 10

 4.3.4 Fuse 10

 4.4 POWER SUPPLY VOLTAGE SEQUENCE..... 11

 4.4.1 Sequence for LCD panel signal processing board..... 11

 4.5 CONNECTIONS AND FUNCTIONS FOR INTERFACE PINS 12

 4.5.1 LCD panel signal processing board 12

 4.5.2 Backlight lamp 13

 4.5.3 Positions of a plug and a socket 13

 4.5.4 Connection between receiver and transmitter for LVDS..... 14

 4.6 DISPLAY COLORS AND INPUT DATA SIGNALS 16

 4.7 DISPLAY POSITIONS 17

 4.8 SCANNING DIRECTIONS 17

 4.9 INPUT SIGNAL TIMINGS FOR LCD PANEL SIGNAL PROCESSING BOARD 18

 4.9.1 Outline of input signal timings 18

 4.9.2 Timing characteristics 19

 4.9.3 Input signal timing chart 20

 4.10 OPTICS 21

 4.10.1 Optical characteristics 21

 4.10.2 Definition of contrast ratio 22

 4.10.3 Definition of luminance uniformity..... 22

 4.10.4 Definition of response times..... 22

 4.10.5 Definition of viewing angles 22

5. RELIABILITY TESTS 23

6. PRECAUTIONS..... 24

 6.1 MEANING OF CAUTION SIGNS 24

 6.2 CAUTIONS 24

 6.3 ATTENTIONS..... 24

 6.3.1 Handling of the product..... 24

 6.3.2 Environment 25

 6.3.3 Characteristics 25

 6.3.4 Other..... 25

7. OUTLINE DRAWINGS 26

 7.1 FRONT VIEW 26

 7.2 REAR VIEW 27

REVISION HISTORY 28

1. OUTLINE

1.1 STRUCTURE AND PRINCIPLE

NL10276BC30-10 module is composed of the amorphous silicon thin film transistor liquid crystal display (a-Si TFT LCD) panel structure with driver LSIs for driving the TFT (Thin Film Transistor) array and a backlight.

The a-Si TFT LCD panel structure is injected liquid crystal material into a narrow gap between the TFT array glass substrate and a color-filter glass substrate.

Color (Red, Green, Blue) data signals from a host system (e.g. PC, signal generator, etc.) are modulated into best form for active matrix system by a signal processing board, and sent to the driver LSIs which drive the individual TFT arrays.

The TFT array as an electro-optical switch regulates the amount of transmitted light from the backlight assembly, when it is controlled by data signals. Color images are created by regulating the amount of transmitted light through the TFT array of red, green and blue dots.

1.2 APPLICATIONS

- Monitor for PC

1.3 FEATURES

- LVDS interface
- Selectable LVDS input map
- Wide color gamut
- High contrast
- Edge light type
- Replaceable lamp for backlight (Inverter less)

2. GENERAL SPECIFICATIONS

Display area	304.128 (W) × 228.096 (H) mm (typ.)	
Diagonal size of display	38.0 cm (15.0 inches)	
Drive system	a-Si TFT active matrix	
Display color	16,777,216 colors (6bit+FRC)	
Pixel	1,024 (H) × 768 (V) pixels	
Pixel arrangement	RGB (Red dot, Green dot, Blue dot) vertical stripe	
Dot pitch	0.099 (W) × 0.297 (H) mm	
Pixel pitch	0.297 (W) × 0.297 (H) mm	
Module size	328.0 (W) × 252.0 (H) × 11.0 (D) mm (typ.)	
Weight	970 g (typ.)	3
Contrast ratio	450:1 (typ.)	3
Viewing angle	At the contrast ratio 10:1 <ul style="list-style-type: none"> • Horizontal: Right side 60° (typ.), Left side 60° (typ.) • Vertical: Up side 40° (typ.), Down side 60° (typ.) 	
Designed viewing direction	<ul style="list-style-type: none"> • Viewing direction without image reversal: up side (12 o'clock) • Viewing direction with contrast peak: normal axis • Viewing angle with optimum grayscale ($\gamma=2.2$): normal axis 	3
Polarizer surface	Antiglare	
Polarizer pencil-hardness	3H (min.) [by JIS K5400]	
Color gamut	At LCD panel center 60 % (typ.) [against NTSC color space]	
Response time	Ton (white 90% → black 10%) 8 ms (typ.)	3
Luminance	At IBL=7.5mArms / lamp 250 cd/m ² (typ.)	3
Signal system	LVDS 1port (Receiver: THC63LVDF84A, THine Electronics Inc.) [8-bit digital signals for data of RGB colors, Dot clock (CLK), Data enable (DE)]	
Power supply voltage	LCD panel signal processing board: 3.3V	
Backlight	Edge light type: 2 cold cathode fluorescent lamps (Replaceable part <ul style="list-style-type: none"> • Lamp holder set: Type No. TBD)	
Power consumption	At IBL=7.5mArms / lamp and checkered flag pattern 9.4W (typ.)	3

3. BLOCK DIAGRAM

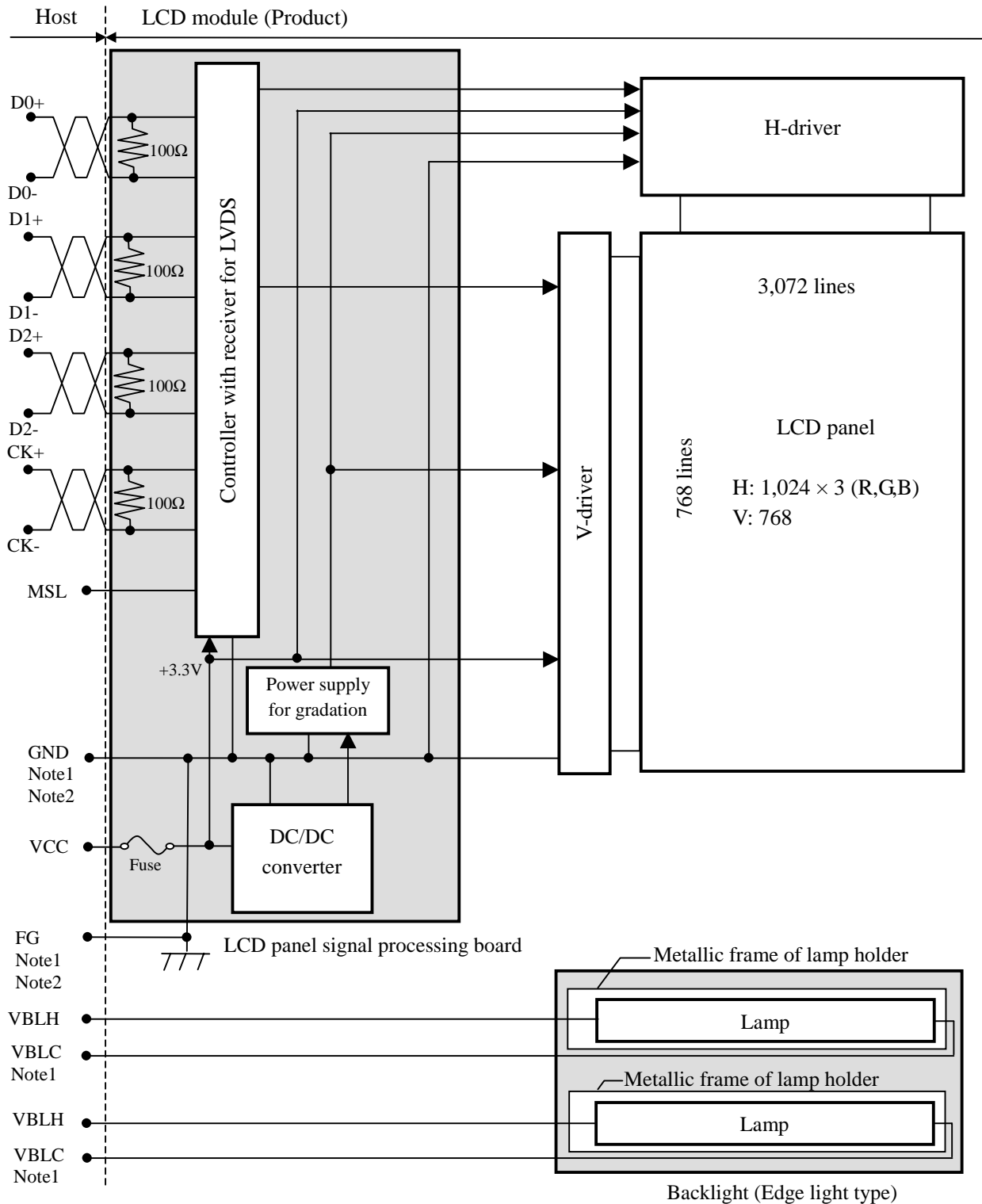

Note1: Connections between GND (Signal ground), FG (Frame ground) and VBLC (Lamp low voltage terminal) in the product

GND - FG	Connected
GND - VBLC	Not connected
FG - VBLC	Not connected

Note2: These grounds should be connected together in customer equipment.

4. DETAILED SPECIFICATIONS

4.1 MECHANICAL SPECIFICATIONS

Parameter	Specification	Unit
Module size	328.0 ± 0.5 (W) × 252.0 ± 0.5 (H) × 11.0 ± 0.5 (D) Note1	mm
Display area	304.128 (W) × 228.096 (H) Note1	mm
Weight	970 (typ.), 1050 (max.)	g

3

Note1: See "7. OUTLINE DRAWINGS".

4.2 ABSOLUTE MAXIMUM RATINGS

Parameter	Symbol	Rating	Unit	Remarks	
Power supply voltage	LCD panel signal board	VCC	-0.3 to +3.6	V	Ta = 25°C
	Lamp voltage Note1	VBLH	TBD	Vrms	
Input voltage for signals	Display signals Note2	VD	-0.3 to +3.6	V	Ta = 25°C
	Function signals Note3	VFD	-0.3 to VCC	V	
Storage temperature		Tst	-20 to +60	°C	-
Operating temperature	Front surface	TopF	0 to +50	°C	Note3
	Rear surface	TopR	0 to TBD	°C	Note4
Relative humidity Note5	RH	≤ 95	%	Ta ≤ 40°C	
		≤ 85	%	40 < Ta ≤ 50°C	
Absolute humidity Note5	AH	≤ 70 Note6	g/m ³	Ta > 50°C	
Operating altitude	-	≤ 4,850	m	0°C ≤ Ta ≤ 50°C	
Storage altitude	-	≤ 13,600	m	-20°C ≤ Ta ≤ 60°C	

3

Note1: "VBLH" is the voltage value between low voltage terminal (Cold) and high voltage terminal (Hot).

Note2: Display signals are D0+/-, D1+/-, D2+/- and CK+/-.

Note3: Function signal is MSL.

Note4: Measured at center of LCD panel surface (including self-heat)

Note5: Measured at center of LCD module's rear shield surface (including self-heat)

Note6: No condensation

Note7: Ta = 50°C, RH = 85%

3

4.3 ELECTRICAL CHARACTERISTICS

4.3.1 Driving for LCD panel signal processing board

(Ta = 25°C)

Parameter	Symbol	Min.	Typ.	Max.	Unit	Remarks	
Power supply voltage	VCC	3.0	3.3	3.6	V	-	
Power supply current	ICC	-	290 Note1	600 Note2	mA	at VCC = 3.3V	
Permissible ripple voltage	VRP	-	-	100	mV	for VCC	
Differential input threshold voltage for LVDS receiver	Low	VTL	-100	-	mV	at VCM=1.2V Note3	
	High	VTH	-	-	+100		mV
Input voltage width for LVDS receiver	Vi	0	-	2.4	V	-	
Terminating resistor	RT	-	100	-	Ω	-	
Input voltage for MSL signal	Low	VFL	0	-	0.8	V	-
	High	VFH	2.0	-	VCC	V	

Note1: Checkered flag pattern (by EIAJ ED-2522)

Note2: Pattern for maximum current

Note3: Common mode voltage for LVDS receiver

4.3.2 Driving for backlight lamp

(Ta=25°C Note1)

Parameter	Symbol	Min.	Typ.	Max.	Unit	Remarks	
Lamp current	IBL	3.5	7.5	8.0	mArms	at IBL=7.5mArms: L=250cd/m ² (Typ.) Note3	3
Lamp voltage	VBLH	-	560	-	Vrms	Note2,Note3	3
Lamp starting voltage	VS	1500	-	-	Vrms	Ta = 0°C Note2, Note3	
		1300	-	-	Vrms	Ta = 25°C Note2, Note3	
Oscillation frequency	FO	45	54	65	kHz	Note4	3

Note1: This product consists of 2 backlight lamps, and these specifications are for each lamp.

Note2: The lamp voltage cycle between lamps should be kept on a same phase. "VS" and "VBLH" are the voltage value between low voltage side (Cold) and high voltage side (Hot).

Note3: The asymmetric ratio of working waveform for lamps (Lamp voltage peak ratio, Lamp current peak ratio and waveform space ratio) should be less than 5 % (See the following figure.). If the waveform is asymmetric, DC (Direct current) element apply into the lamp. In this case, a lamp lifetime may be shortened, because a distribution of a lamp enclosure substance inclines toward one side between low voltage terminal (Cold terminal) and high voltage terminal (Hot terminal).

When design the backlight inverter, evaluate asymmetric of lamp working waveform sufficiently.

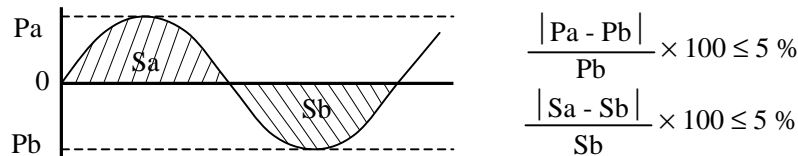

Pa: Supply voltage/current peak for positive, Pb: Supply voltage/current peak for negative
Sa: Waveform space for positive part, Sb: Waveform space for negative part

Note4: In case "FO" is not the recommended value, beat noise may display on the screen, because of interference between "FO" and "1/th". Recommended value of "FO" is as following.

$$FO = \frac{1}{4} \times \frac{1}{th} \times (2n-1)$$

th: Horizontal cycle period (See "4.9.2 Timing characteristics".)

n: Natural number (1, 2, 3)

Note5: Method of lamp cable installation may invite fluctuation of lamp current and voltage or asymmetric of lamp working waveform. When design the backlight inverter, evaluate the fluctuation of lamp current and voltage or asymmetric of lamp working waveform sufficiently.

4.3.3 Power supply voltage ripple

This product works, even if the ripple voltage levels are beyond the permissible values as following the table, but there might be noise on the display image.

Parameter	Power supply voltage	Ripple voltage (Measure at input terminal of power supply)	Note1 (Measure at input terminal of power supply)	Unit
VCC	3.3 V	≤ 100		mVp-p

Note1: The permissible ripple voltage includes spike noise.

4.3.4 Fuse

Parameter	Fuse		Rating	Fusing current	Remarks
	Type	Supplier			
VCC	TF16SN2.50	KOA Corporation	2.5 A	5.0 A	Note1
			32 V		

Note1: The power supply capacity should be more than the fusing current. If the power supply capacity is less than the fusing current, the fuse may not blow for a short time, and then nasty smell, smoking and so on may occur.

4.4 POWER SUPPLY VOLTAGE SEQUENCE

4.4.1 Sequence for LCD panel signal processing board

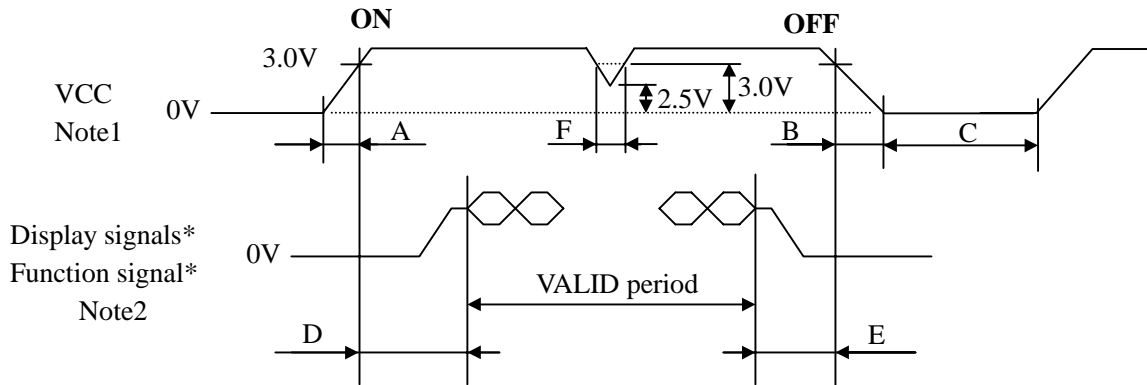

* These signals should be measured at the terminal of 100Ω resistor.

Parameter	Symbol	Min.	Typ.	Max.	Unit	Remarks
Input voltage sequence	A	-	-	10	ms	-
	B	0.01	-	10	ms	-
	C	500	-	-	ms	-
	D	0.01	-	50	ms	-
	E	0.01	-	50	ms	-
VCC dip condition	F	-	-	20	ms	Note3

Note1: In terms of voltage variation (voltage drop) while VCC rising edge is below 3.0V, a protection circuit may work, and then this product may not work.

Note2: Display signals (D0+/-, D1+/-, D2+/- and CK+/-) and function signal (MSL) must be "0" voltage, exclude the VALID period (See above sequence diagram). If these signals are higher than 0.3V, the internal circuit is damaged.

If some of display and function signals of this product are cut while this product is working, even if the signal input to it once again, it might not work normally. If customer stops the display and function signals, they should be cut VCC.

Note3: VCC should be 2.5V or more while VCC ON period.

Note4: The backlight power supply voltage should be inputted within the valid period of display and function signals, in order to avoid unstable data display.

4.5 CONNECTIONS AND FUNCTIONS FOR INTERFACE PINS

4.5.1 LCD panel signal processing board

CN1 socket (Module side): DF-14H-20P-1.25H (Hirose Electric Co., Ltd.)

Adaptable plug: DF14-20S-1.25C (Hirose Electric Co., Ltd.)

Pin No.	Symbol	Signal	Remarks
1	VCC	Power supply	-
2	VCC		
3	GND	Ground	-
4	GND		
5	D0-	Pixel data	Note2
6	D0+		
7	GND	Ground	-
8	D1-	Pixel data	Note2
9	D1+		
10	GND	Ground	-
11	D2-	Pixel data	Note2
12	D2+		
13	GND	Ground	-
14	CLK-	Pixel clock	Note2
15	CLK+		
16	GND	Ground	-
17	D3-	Pixel data	Note2
18	D3+		
19	GND	Ground	-
20	MSL	Selection of LVDS input map Note1	High: Input map A mode Low or open: Input map B mode

Note1: See "4.5.4 Connection between receiver and transmitter for LVDS".

Note2: Twist pair wires with 100Ω (Characteristic impedance) should be connected between LCD panel signal processing board and LVDS transmitter.

4.5.2 Backlight lamp

Attention: VBLH and VBLC must be connected correctly. If customer connects wrongly, customer will be hurt and the product will be broken.

CN201 plug: BHR-03VS-1 (J.S.T Mfg. Co., Ltd.)

Adaptable socket: SM02(8.0)B-BHS-1-TB (J.S.T Mfg. Co., Ltd.)

3

Pin No.	Symbol	Signal	Remarks
1	VBLH	High voltage terminal (Hot)	Cable color: Pink
2	N.C.	-	-
3	VBLC	Low voltage terminal (Cold)	Cable color: White

CN201 plug: BHR-03VS-1 (J.S.T Mfg. Co., Ltd.)

Adaptable socket: SM02(8.0)B-BHS-1-TB (J.S.T Mfg. Co., Ltd.)

3

Pin No.	Symbol	Signal	Remarks
1	VBLH	High voltage terminal (Hot)	Cable color: Pink
2	N.C.	-	-
3	VBLC	Low voltage terminal (Cold)	Cable color: White

4.5.3 Positions of a plug and a socket

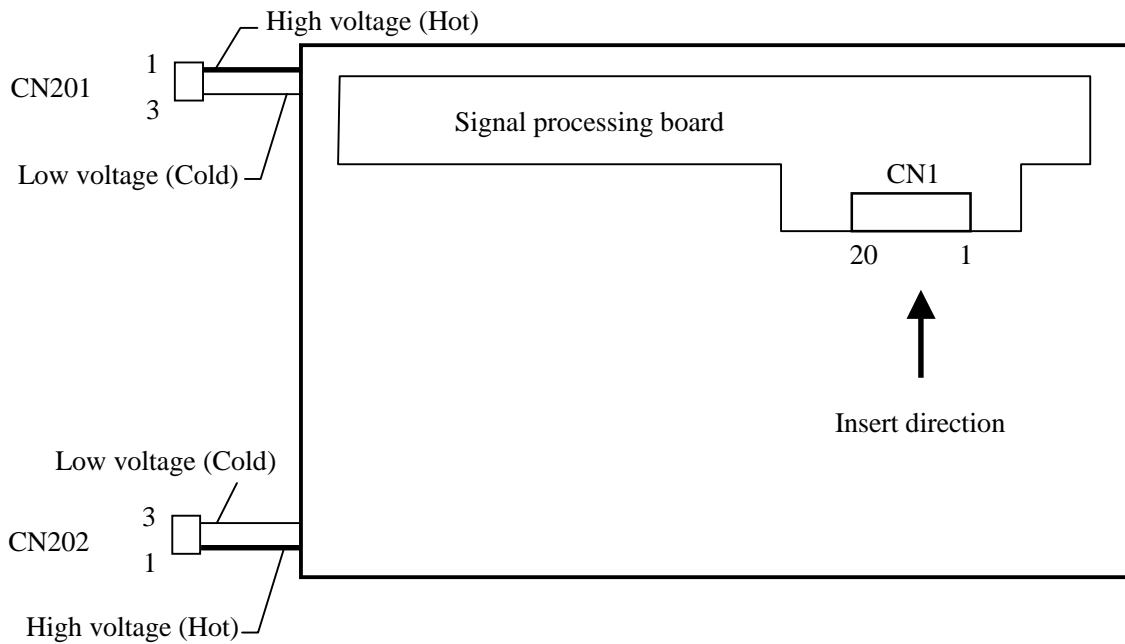

4.5.4 Connection between receiver and transmitter for LVDS

(1) Input LVDS map A (MSL: "High")

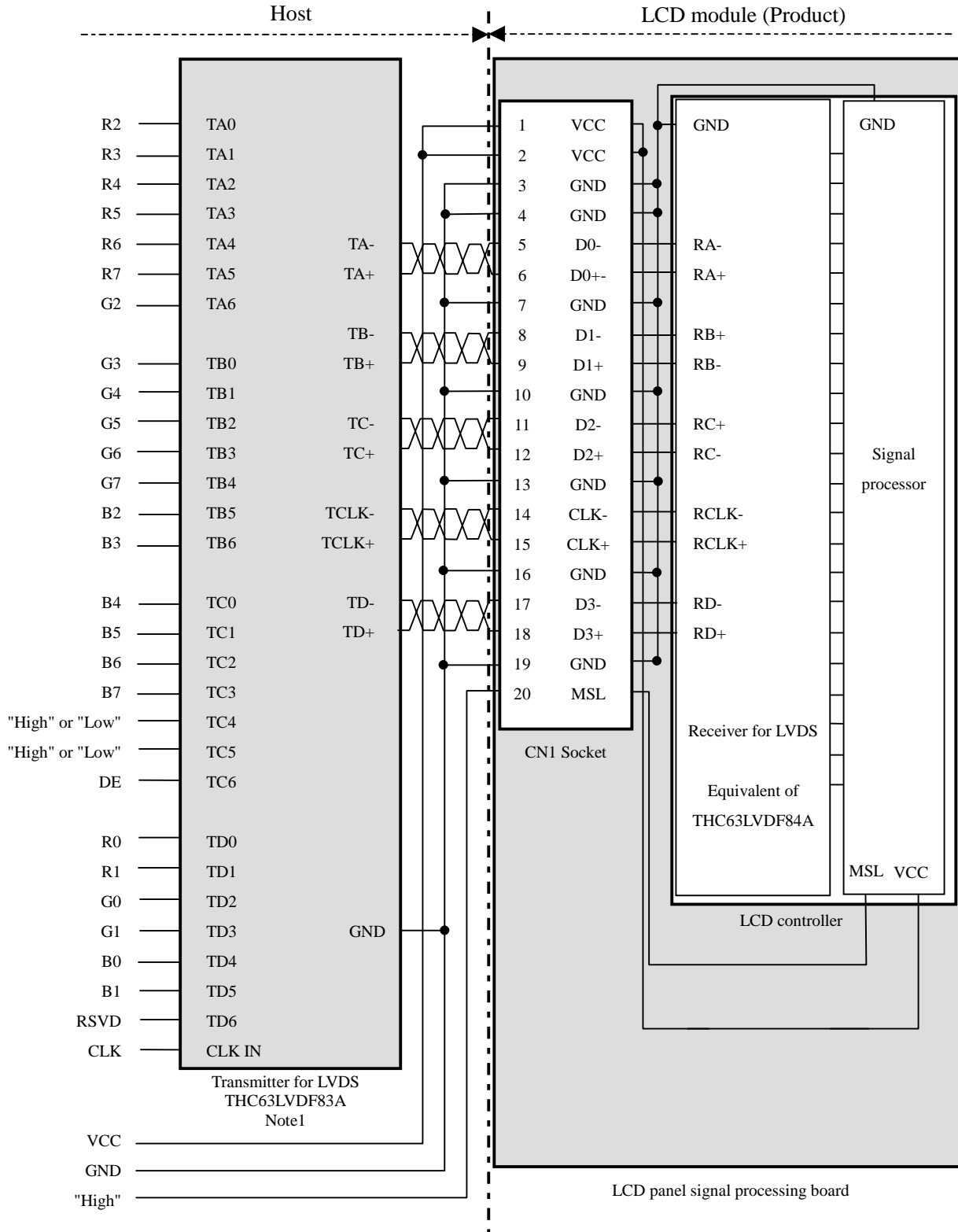

Note1: Recommended transmitter

See the data sheet for THC63LVDM63A (THine Electronics Inc.).

Note2: LSB (Least Significant Bit) – R0, G0, B0 MSB (Most Significant Bit) – R7, G7, B7

(2) Input LVDS map B (MSL: "Low" or "open")

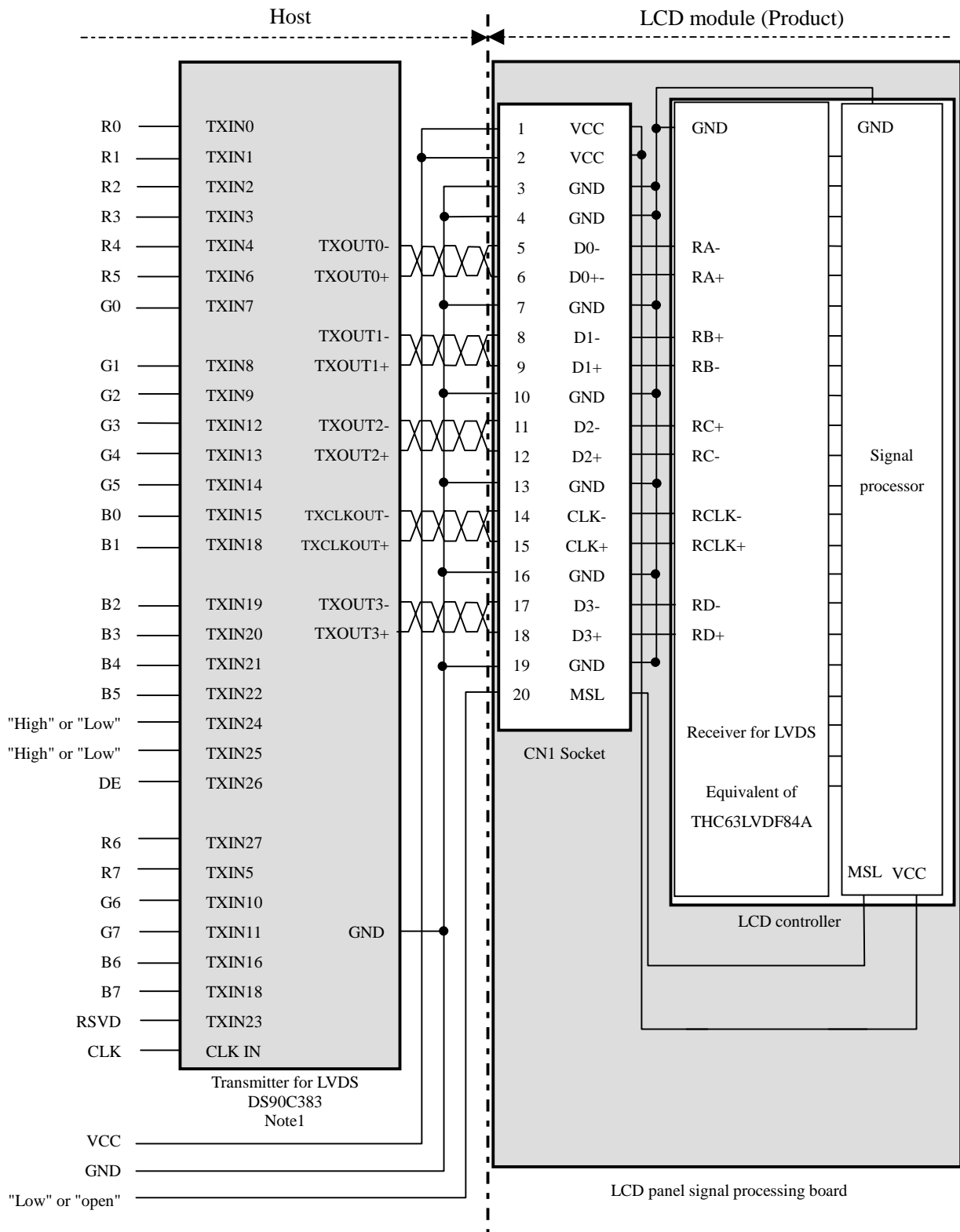

Note1: Recommended transmitter

See the data sheet for DS90C383 (National Semiconductor).

Note2: LSB (Least Significant Bit) – R0, G0, B0 MSB (Most Significant Bit) – R7, G7, B7

4.6 DISPLAY COLORS AND INPUT DATA SIGNALS

This product can display in equivalent to 16,777,216 colors in 256 scale. Also the relation between display colors and input data signals is as the following table.

Display colors		Data signal (0: Low level, 1: High level)																							
		R 7	R 6	R 5	R 4	R 3	R 2	R 1	R 0	G 7	G 6	G 5	G 4	G 3	G 2	G 1	G 0	B 7	B 6	B 5	B 4	B 3	B 2	B 1	B 0
Basic Colors	Black	0	0	0	0	0	0	0	0	0	0	0	0	0	0	0	0	0	0	0	0	0	0	0	0
	Blue	0	0	0	0	0	0	0	0	0	0	0	0	0	0	0	0	1	1	1	1	1	1	1	1
	Red	1	1	1	1	1	1	1	1	0	0	0	0	0	0	0	0	0	0	0	0	0	0	0	0
	Magenta	1	1	1	1	1	1	1	1	0	0	0	0	0	0	0	0	1	1	1	1	1	1	1	1
	Green	0	0	0	0	0	0	0	0	1	1	1	1	1	1	1	1	0	0	0	0	0	0	0	0
	Cyan	0	0	0	0	0	0	0	0	1	1	1	1	1	1	1	1	1	1	1	1	1	1	1	1
	Yellow	1	1	1	1	1	1	1	1	1	1	1	1	1	1	1	1	0	0	0	0	0	0	0	0
	White	1	1	1	1	1	1	1	1	1	1	1	1	1	1	1	1	1	1	1	1	1	1	1	1
Red grayscale	Black	0	0	0	0	0	0	0	0	0	0	0	0	0	0	0	0	0	0	0	0	0	0	0	0
		0	0	0	0	0	0	0	1	0	0	0	0	0	0	0	0	0	0	0	0	0	0	0	0
	dark	0	0	0	0	0	0	1	0	0	0	0	0	0	0	0	0	0	0	0	0	0	0	0	0
	↑																								
	↓																								
	bright	1	1	1	1	1	1	0	1	0	0	0	0	0	0	0	0	0	0	0	0	0	0	0	0
Red	1	1	1	1	1	1	1	0	0	0	0	0	0	0	0	0	0	0	0	0	0	0	0	0	
Red	1	1	1	1	1	1	1	1	0	0	0	0	0	0	0	0	0	0	0	0	0	0	0	0	
Green grayscale	Black	0	0	0	0	0	0	0	0	0	0	0	0	0	0	0	0	0	0	0	0	0	0	0	0
		0	0	0	0	0	0	0	0	0	0	0	0	0	0	0	1	0	0	0	0	0	0	0	0
	dark	0	0	0	0	0	0	0	0	0	0	0	0	0	0	1	0	0	0	0	0	0	0	0	0
	↑																								
	↓																								
	bright	0	0	0	0	0	0	0	0	1	1	1	1	1	1	0	1	0	0	0	0	0	0	0	0
Green	0	0	0	0	0	0	0	0	1	1	1	1	1	1	1	0	0	0	0	0	0	0	0	0	
Green	0	0	0	0	0	0	0	0	1	1	1	1	1	1	1	1	0	0	0	0	0	0	0	0	
Blue grayscale	Black	0	0	0	0	0	0	0	0	0	0	0	0	0	0	0	0	0	0	0	0	0	0	0	0
		0	0	0	0	0	0	0	0	0	0	0	0	0	0	0	0	0	0	0	0	0	0	0	1
	dark	0	0	0	0	0	0	0	0	0	0	0	0	0	0	0	0	0	0	0	0	0	0	1	0
	↑																								
	↓																								
	bright	0	0	0	0	0	0	0	0	0	0	0	0	0	0	0	0	1	1	1	1	1	1	0	1
Blue	0	0	0	0	0	0	0	0	0	0	0	0	0	0	0	0	1	1	1	1	1	1	1	0	
Blue	0	0	0	0	0	0	0	0	0	0	0	0	0	0	0	0	1	1	1	1	1	1	1	1	

4.7 DISPLAY POSITIONS

The following table is the coordinates per pixel (See figure of "4.8 SCANNING DIRECTIONS".).

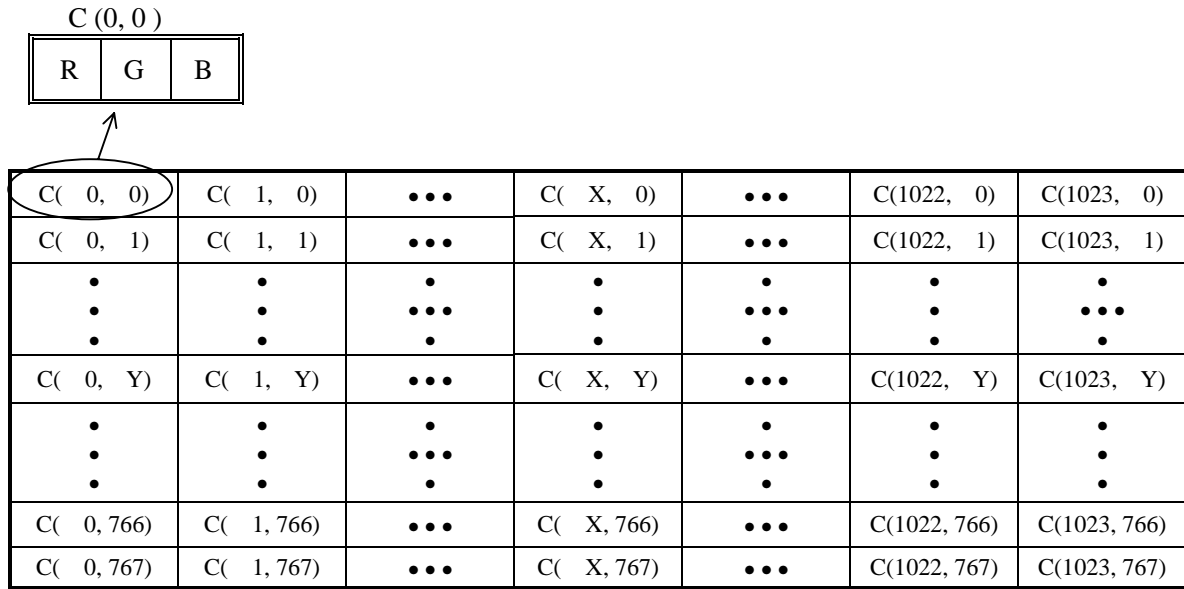

4.8 SCANNING DIRECTIONS

The following figures are seen from a front view. Also the arrow shows the direction of scan.

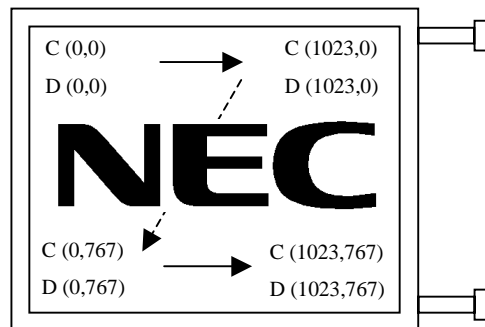

Note1: Meaning of C (X, Y) and D (X, Y)

C (X, Y): The coordinates of the display position (See "4.7 DISPLAY POSITIONS".)

D (X, Y): The data number of input signal for LCD panel signal processing board

4.9 INPUT SIGNAL TIMINGS FOR LCD PANEL SIGNAL PROCESSING BOARD

4.9.1 Outline of input signal timings

• Horizontal signal

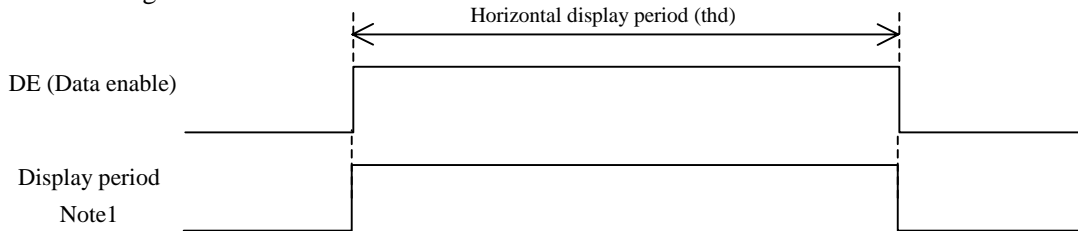

Note1: This diagram indicates virtual signal for set up to timing.

• Vertical signal

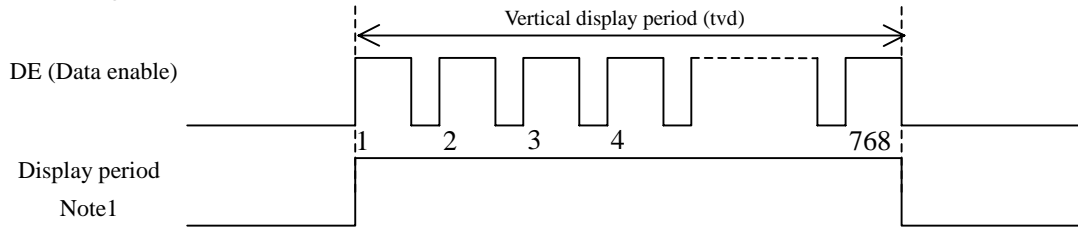

Note1: This diagram indicates virtual signal for set up to timing.

4.9.2 Timing characteristics

Parameter		Symbol	Min.	Typ.	Max.	Unit	Remarks	
CLK	Frequency	1/tc	60.0	65.0	70.0	MHz	15.384 ns (typ.)	
	Duty	-	-			ns	Note2	
	Rise time, Fall time	-				ns		
DATA	CLK-DATA	Setup time	-	-			ns	Note2
		Hold time	-				ns	
	Rise time, Fall time	-	ns					
DE	Horizontal	Cycle	th	12.3	20.676	-	μ s	48.363 kHz (typ.) Note1 Note2 Note3 Note4
				1050	1344	1800	CLK	
	Display period	thd	1024			CLK	Note1	
	Vertical (One frame)	Cycle	tv	15.5	16.666	20.0	ms	
				770	806	-	H	
	Display period	tvd	768			H		
CLK-DE	Setup time	-	-			ns	Note2	
	Hold time	-				ns		
Rise time, Fall time	-	ns						

3

3

Note1: Definition of parameters is as follows.

$$t_c = 1\text{CLK}, t_h = 1\text{H}$$

Note2: See the data sheet of LVDS transmitter.

Note3: Both of "time" and "CLK number" of the "th" must keep the Minimum value of specification.

Note4: "th" must keep the fluctuation within ± 1 CLK, because of avoidance of image sticking.

4.9.3 Input signal timing chart

Horizontal timing

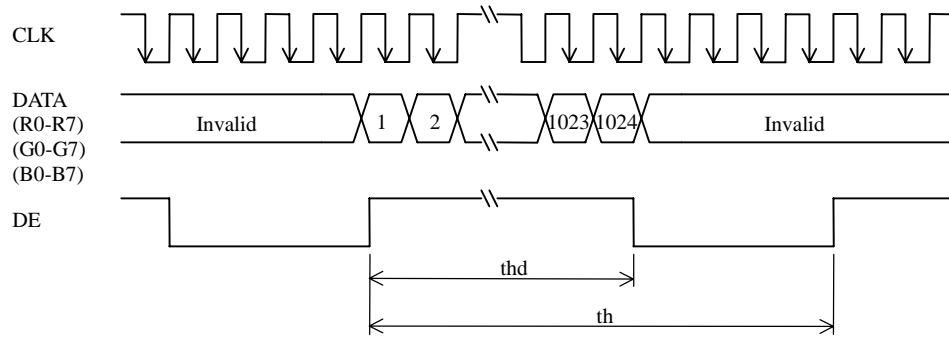

Vertical timing

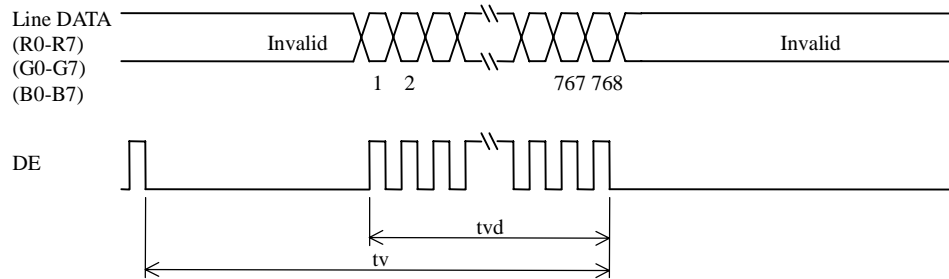

4.10 OPTICS

4.10.1 Optical characteristics

Parameter	Note1	Condition	Symbol	Min.	Typ.	Max.	Unit	Remarks
Luminance		White at center $\theta R = 0^\circ, \theta L = 0^\circ, \theta U = 0^\circ, \theta D = 0^\circ$	L	200	250	-	cd/m ²	-
Contrast ratio		White/Black at center $\theta R = 0^\circ, \theta L = 0^\circ, \theta U = 0^\circ, \theta D = 0^\circ$	CR	350	450	-	-	Note2
Luminance uniformity		-	LU	-	1.1	1.3	-	Note3
Chromaticity	White	x coordinate	Wx	-	0.313	-	-	Note4
		y coordinate	Wy	-	0.329	-	-	
	Red	x coordinate	Rx	-	0.624	-	-	
		y coordinate	Ry	-	0.351	-	-	
	Green	x coordinate	Gx	-	0.325	-	-	
		y coordinate	Gy	-	0.571	-	-	
Blue	x coordinate	Bx	-	0.144	-	-		
	y coordinate	By	-	0.010	-	-		
Color gamut		$\theta R = 0^\circ, \theta L = 0^\circ, \theta U = 0^\circ, \theta D = 0^\circ$ at center, against NTSC color space	C	50	60	-	%	
Response time		White to black	Ton	-	8	15	ms	Note5
		Black to white	Toff	-	17	25	ms	Note6
Viewing angle	Right	$\theta U = 0^\circ, \theta D = 0^\circ, CR = 10$	θR	50	60	-	°	Note7
	Left	$\theta U = 0^\circ, \theta D = 0^\circ, CR = 10$	θL	50	60	-	°	
	Up	$\theta R = 0^\circ, \theta L = 0^\circ, CR = 10$	θU	30	40	-	°	
	Down	$\theta R = 0^\circ, \theta L = 0^\circ, CR = 10$	θD	35	60	-	°	

Note1: Measurement conditions are as follows.

Ta = 25°C, VCC = 3.3V, IBL = 7.5mArms/lamp, Display mode: XGA, Horizontal cycle = 48.363kHz, Vertical cycle = 60.000Hz

Optical characteristics are measured at luminance saturation after 20minutes from working the product, in the dark room. Also measurement method for luminance is as follows.

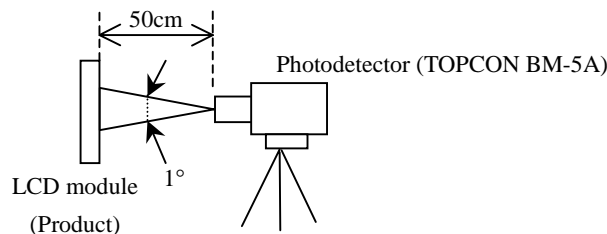

Note2: See "4.10.2 Definition of contrast ratio".

Note3: See "4.10.3 Definition of luminance uniformity".

Note4: These coordinates are found on CIE 1931 chromaticity diagram.

Note5: Product surface temperature: TopF = TBD°C

Note6: See "4.10.4 Definition of response times".

Note7: See "4.10.5 Definition of viewing angles".

4.10.2 Definition of contrast ratio

The contrast ratio is calculated by using the following formula.

$$\text{Contrast ratio (CR)} = \frac{\text{Luminance of white screen}}{\text{Luminance of black screen}}$$

4.10.3 Definition of luminance uniformity

The luminance uniformity is calculated by using following formula.

$$\text{Luminance uniformity (LU)} = \frac{\text{Maximum luminance from ① to ⑤}}{\text{Minimum luminance from ① to ⑤}}$$

The luminance is measured at near the 5 points shown below.

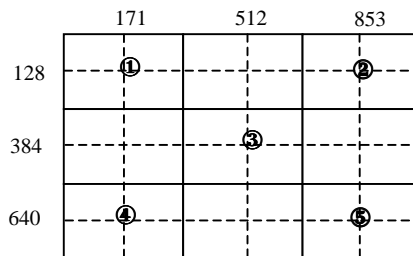

4.10.4 Definition of response times

Response time is measured, the luminance changes from "white" to "black", or "black" to "white" on the same screen point, by photo-detector. Ton is the time it takes the luminance change from 90% down to 10%. Also Toff is the time it takes the luminance change from 10% up to 90% (See the following diagram.).

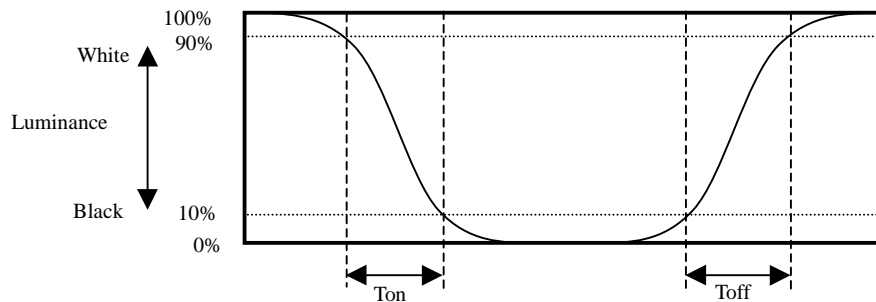

4.10.5 Definition of viewing angles

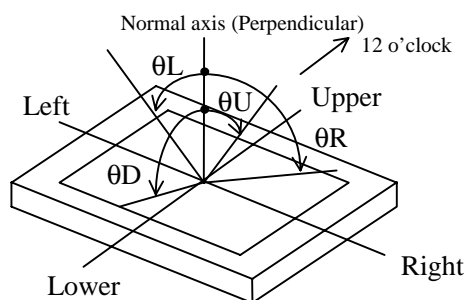

5. RELIABILITY TESTS

Test item		Condition	Judgement
High temperature and humidity (Operation)		① 50 ± 2°C, RH = 85%, 240hours ② Display data is black.	No display malfunctions Note1
Heat cycle (Operation)		① 0 ± 3°C...1hour 55 ± 3°C...1hour ② 50cycles, 4hours/cycle ③ Display data is black.	
Thermal shock (Non operation)		① -20 ± 3°C...30minutes 60 ± 3°C...30minutes ② 100cycles, 1hour/cycle ③ Temperature transition time is within 5 minutes.	
ESD (Operation)		① 150pF, 150Ω, ±10kV ② 9 places on a panel surface Note2 ③ 10 times each places at 1 sec interval	
Dust (Operation)		① Sample dust: No. 15 (by JIS-Z8901) ② 15 seconds stir ③ 8 times repeat at 1 hour interval	
Vibration (Non operation)		① 5 to 100Hz, 11.76m/s ² ② 1 minute/cycle ③ X, Y, Z direction ④ 10 times each directions	
Mechanical shock (Non operation)		① 294m/ s ² , 11ms ② ±X, ±Y, ±Z direction ③ 3 times each directions	
Low pressure	operation	① 53.3 kPa ② 0°C±3°C...24 hours ③ 50°C±3°C...24 hours	No display malfunctions Note1
	non-operation	① 15 kPa ② -20°C±3°C...24 hours ③ -60°C±3°C...24 hours	

Note1: Display functions are checked under the same conditions as product inspection.

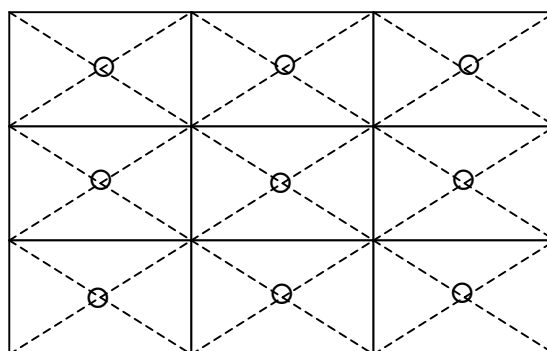

Note2: See the following figure for discharge points.



6. PRECAUTIONS

6.1 MEANING OF CAUTION SIGNS

The following caution signs have very important meaning. **Be sure to read "6.2 CAUTIONS", after understanding this contents!**

	This sign has the meaning that customer will get an electrical shock, if customer has wrong operations.
	This sign has the meaning that customer will be injured by himself, if customer has wrong operations.

6.2 CAUTIONS

	* Do not touch the lamp cables while turn on. Customer will be in danger of an electric shock.
---	---

	<p>* Pay attention to burn injury for the working IC!</p> <p>* Do not shock and press the LCD panel and the backlight lamp! There is a danger of breaking, because they are made of glass. (Shock: To be not greater 1176m/s² and to be not greater 2ms, Pressure: To be not greater 19.6N)</p>
--	--

6.3 ATTENTIONS

6.3.1 Handling of the product

- ① Take hold of both ends without touch the circuit board when customer pulls out products (LCD modules) from inner packing box. If customer touches it, products may be broken down or out of adjustment, because of stress to mounting parts.
- ② Do not hook cables nor pull connection cables such as flexible cable and so on, for fear of damage.
- ③ If customer puts down the product temporarily, the product puts on flat subsoil as a display side turns down.
- ④ Take the measures of electrostatic discharge such as earth band, ionic shower and so on, when customer deals with the product, because products may be damaged by electrostatic.
- ⑤ The torque for mounting screws must never exceed 0.34N·m. Higher torque values might result in distortion of the bezel.
- ⑥ Do not press or rub on the sensitive display surface. If customer clean on the panel surface, NEC Corporation recommends using the cloth with ethanolic liquid such as screen cleaner for LCD.
- ⑦ Do not push-pull the interface connectors while the product is working, because wrong power sequence may break down the product.
- ⑧ Do not bend lamp cables from the foundation of the lamp holder, cables may break and the lamp may not light. Operation abnormality of the high-voltage circuit may occur by breaking.

6.3.2 Environment

- ① Do not operate or store in high temperature, high humidity, dewdrop atmosphere or corrosive gases. Keep the product in antistatic pouch in room temperature, because of avoidance for dusts and sunlight, if customer stores the product.
- ② Do not operate in high magnetic field. Circuit boards may be broken down by it.
- ③ Use an original protection sheet on the product surface (polarizer). Adhesive type protection sheet should be avoided, because it may change color or properties of the polarizer.

6.3.3 Characteristics

The following items are neither defects nor failures.

- ① Response time, luminance and color may be changed by ambient temperature.
- ② The LCD may be seemed luminance non-uniformity, flicker, vertical seam or small spot by display patterns.
- ③ Optical characteristics (e.g. luminance, display uniformity, etc.) gradually is going to change depending on operating time, and especially low temperature, because the LCD has cold cathode fluorescent lamps.
- ④ Do not display the fixed pattern for a long time because it may cause image sticking. Use a screen saver, if the fixed pattern is displayed on the screen.
- ⑤ The display color may be changed by viewing angle because of the use of condenser sheet in the backlight.
- ⑥ Optical characteristics may be changed by input signal timings.
- ⑦ The interference noise of input signal frequency for this product's signal processing board and luminance control frequency of customer's backlight inverter may appear on a display. Set up luminance control frequency of backlight inverter so that the interference noise does not appear.

6.3.4 Other

- ① All GND and VCC terminals should be used without a non-connected line.
- ② Do not disassemble a product or adjust volume without permission of NEC Corporation.
- ③ See "**REPLACEMENT MANUAL FOR LAMPHOLDER SET**", if customer would like to replace backlight lamps.
- ④ Pay attention not to insert waste materials inside of products, if customer uses screwdrivers.

7. OUTLINE DRAWINGS

7.1 FRONT VIEW

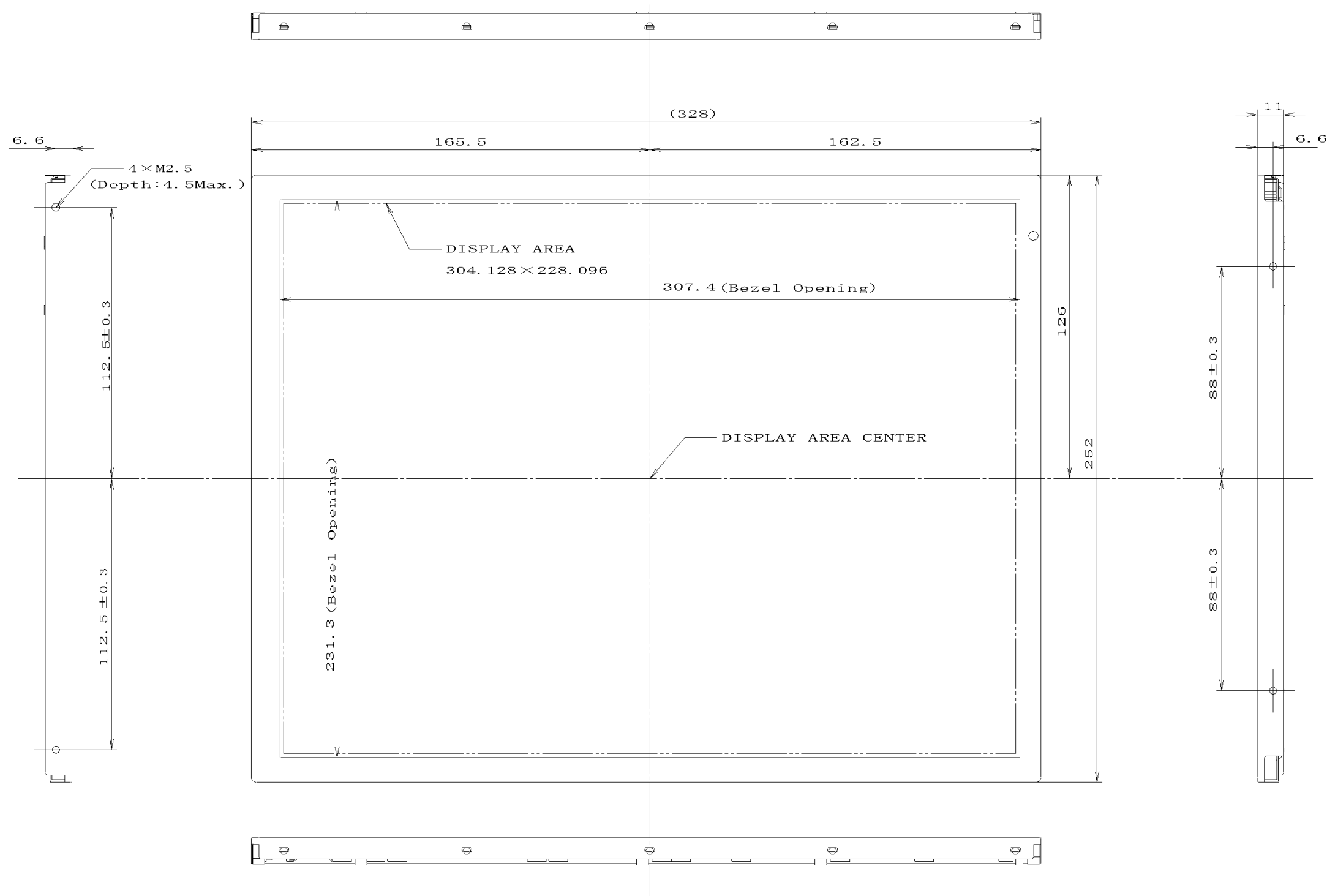

Note1: Not shown tolerances of the dimensions are $\pm 0.5\text{mm}$.
 Note2: The values in parentheses are for reference.
 Note3: The torque for mounting screw should never exceed $0.34\text{N}\cdot\text{m}$.

Unit: mm

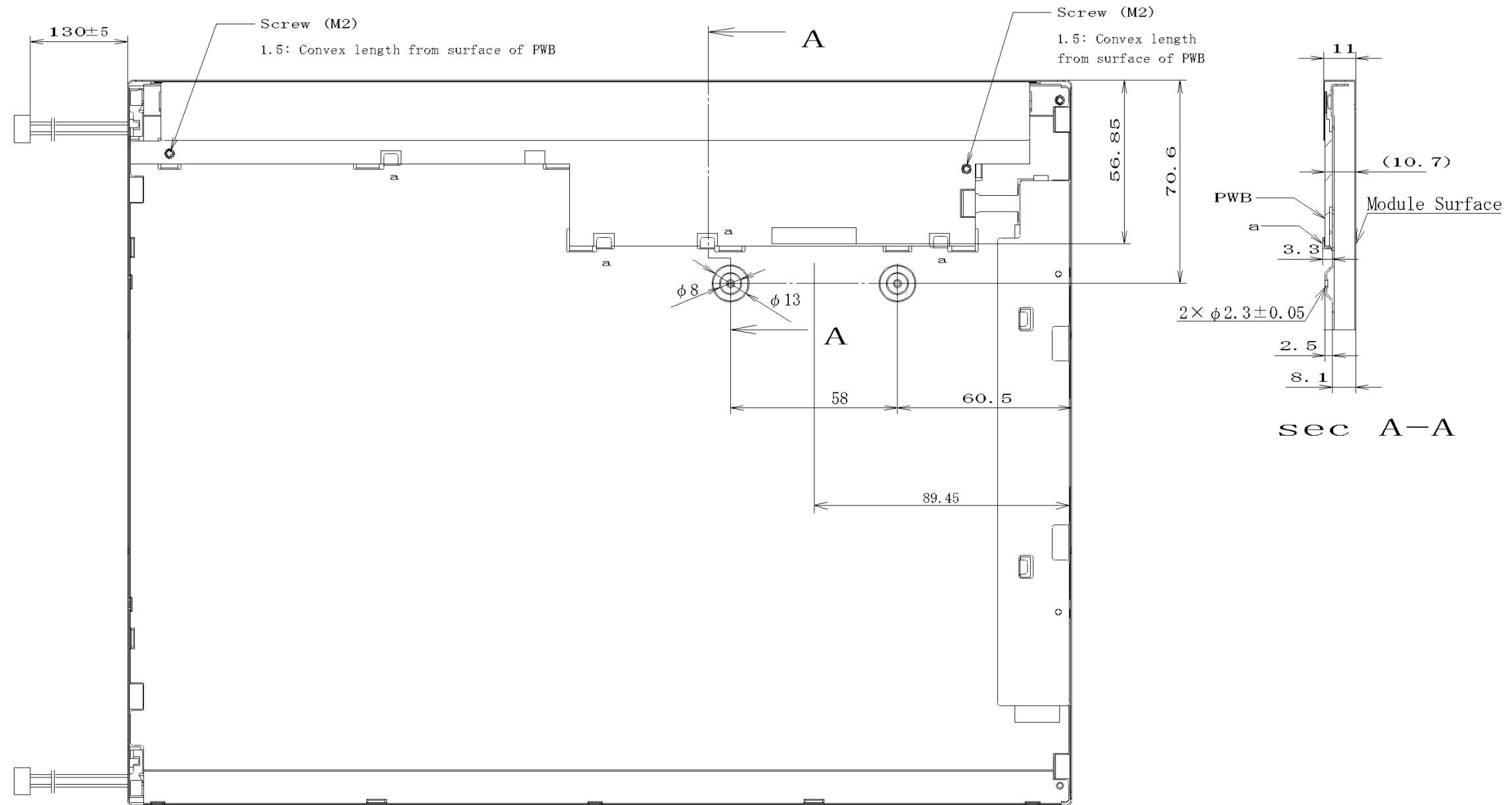









Note1: Not shown tolerances of the dimensions are ± 0.5 mm.
 Note2: The values in parentheses are for reference.
 Note3: The torque for mounting screw should never exceed 0.34 N-m.

Unit: mm

REVISION HISTORY

Edition	Document number	Prepared date	Revision contents and signature
1st edition	DOD-M-1087	July 17, 2002	<p>Revision contents</p> <p>New issue</p> <p>Signature of writer <i>Approved by</i> _____ <i>Checked by</i> _____ <i>Prepared by</i> _____ T. ITO _____ R. KAWASHIMA _____</p>
2nd edition	DOD-M-1154	Aug. 29, 2002	<p>Revision contents</p> <p>P8 Driving for LCD panel signal processing board</p> <ul style="list-style-type: none"> • Permissible ripple voltage - Permissible ripple voltage (VRP) – Remarks: at VCC = 3.3V → for VCC • Differential input threshold voltage for LVDS receive – Remarks: at VOC = 1.2V → at VCM = 1.2V • Input voltage for MSL signal – Low: VF DL → VFL • Input voltage for MSL signal – High: VF DH → VFH <p>P9 Driving for backlight lamp</p> <ul style="list-style-type: none"> • Lamp starting voltage (VS) – 0°C – Min: 1100 → 1500 • Lamp starting voltage (VS) – 25°C – Min: 850 → 1300 <p>Signature of writer <i>Approved by</i> _____ <i>Checked by</i> _____ <i>Prepared by</i> _____ T. ITO _____ N. KANO _____</p>
3rd edition	DOD-M-1260	Dec. 3, 2002	<p>Revision contents</p> <p>P5, P7 Weight: 1050g (typ.), 1100g (max.) → 970g (typ.), 1050g (max.) (changed)</p> <p>P5, P21 • Contrast: TBD (min.), 350 (typ.) → 350 (min.), 450 (typ.) (changed)</p> <ul style="list-style-type: none"> • Response time: → Ton 8ms (typ.), 15ms (max.) (decided) → Toff 17ms (typ.), 25ms (max.) (decided) <p>P5, P9 Lamp current: TBD mA (min.), 6.5mA (typ.), TBD mA (max.)</p> <ul style="list-style-type: none"> → 3.5mA (min.), 7.5mA (typ.), 8.0mA (max.) (decided) <p>P5 • Designed viewing direction: At DPSR: normal scan (deleted)</p> <ul style="list-style-type: none"> • Power consumption: 8.8W → 9.4W <p>P6 Notes (revised)</p> <p>P7 Absolute maximum ratings</p> <ul style="list-style-type: none"> • Lamp-VBLC: Deleted (correction) • Note2: Deleted (correction) <p>P8 Electrical characteristics- Driving for LCD panel signal processing board</p> <ul style="list-style-type: none"> • ICC (mA): 300 Typ., TBD Max. → 290 Typ., 600 Max. (decided) <p>P9 Electrical characteristics- Driving for backlight lamp</p> <ul style="list-style-type: none"> • IBL: Remarks (added) • VBLH: 600Vrms Typ. → 560Vrms Typ. (changed) • Oscillation frequency: → 45kHz Min., 65kHz Max. (decided) <p>P10 Fuse (decided)</p> <p>P13 Connections and functions for interface pins-Backlight lamp</p> <ul style="list-style-type: none"> • Adaptable socket: SM03B-BHS-1 → SM02(8.0)B-BHS-1-TB (correction) <p>P19 Timing characteristics</p> <ul style="list-style-type: none"> • th: → 12.3μs Min. (decided) 1050CLK Min., 1800CLK Max. (decided) • tv: → 15.5ms Min., 20.0ms Max. (decided) 770CLK Min. (decided)

Edition	Document number	Prepared date	Revision contents and signature			
3rd edition	DOD-M-1260	Dec. 3, 2002	<p>P21 Optical characteristics</p> <ul style="list-style-type: none"> • Luminance: → 200cd/m² (Min.) (decided) • Chromaticity-Red, Green, Blue (decided) • Viewing angles : → $\theta_R=50^\circ$ (Min.), $\theta_L=50^\circ$ (Min.), $\theta_U=30^\circ$ (Min.), $\theta_D=35^\circ$ (Min.) (decided) • Note1 (changed) <p>P26, P27 Outline drawings (revised)</p> <p>Signature of writer</p> <table style="width: 100%; border: none;"> <tr> <td style="text-align: center; vertical-align: top;"> <i>Approved by</i>  <hr style="width: 100%;"/> TOSHIHIDE ITO </td> <td style="text-align: center; vertical-align: top;"> <i>Checked by</i>  <hr style="width: 100%;"/> R. KAWASHIMA </td> <td style="text-align: center; vertical-align: top;"> <i>Prepared by</i>  <hr style="width: 100%;"/> N. KANO </td> </tr> </table>	<i>Approved by</i>  <hr style="width: 100%;"/> TOSHIHIDE ITO	<i>Checked by</i>  <hr style="width: 100%;"/> R. KAWASHIMA	<i>Prepared by</i>  <hr style="width: 100%;"/> N. KANO
<i>Approved by</i>  <hr style="width: 100%;"/> TOSHIHIDE ITO	<i>Checked by</i>  <hr style="width: 100%;"/> R. KAWASHIMA	<i>Prepared by</i>  <hr style="width: 100%;"/> N. KANO				