

**TFT COLOR LCD MODULE
NL8060BC31-17**

**31 cm (12.1 type), 800 600 pixels, 262144 colors,
incorporated two lamps/edge-light type backlight**

DESCRIPTION

NL8060BC31-17 is a TFT (thin film transistor) active matrix color liquid crystal display (LCD) module comprising amorphous silicon TFT attached to each signal electrode, a driving circuit, and a backlight.

The 31cm diagonal display area contains 800 600 pixels and can display 262144 color simultaneously.

FEATURES

- High luminance (350 cd/m², typ.)
- Wide viewing angle (Retardation Film) and low reflection
- Smooth polarizer surface (No anti glare treatment)
- Reverse scan function (with DPS signal)
- 6-bit digital RGB signals
- Data enable function (auto recognition)
- Backlight with long-life-time lamps
- Lamp holder replaceable (Type number: TBD)

APPLICATIONS

- Personal computer (PC) for factory automation
- Display terminals for control system
- Monitors for process controller



STRUCTURE AND FUNCTIONS

A color TFT (thin film transistor) LCD module is comprised of a TFT liquid crystal panel structure, LSIs for driving the TFT array, and a backlight assembly. The TFT panel structure is created by sandwiching liquid crystal material in the narrow gap between a TFT array glass substrate and a color filter glass substrate. After the driver LSIs are connected to the panel, the backlight assembly is attached to the backside of the panel.

RGB (red, green, blue) data signals from a source system is modulated into a form suitable for active matrix addressing by the onboard signal processor and sent to the driver LSIs which in turn addresses the individual TFT cells.

Acting as an electro-optical switch, each TFT cell regulates light transmission from the backlight assembly when activated by the data source. By regulating the amount of light passing through the array of red, green, and blue dots, color images are created with clarity.

BLOCK DIAGRAM

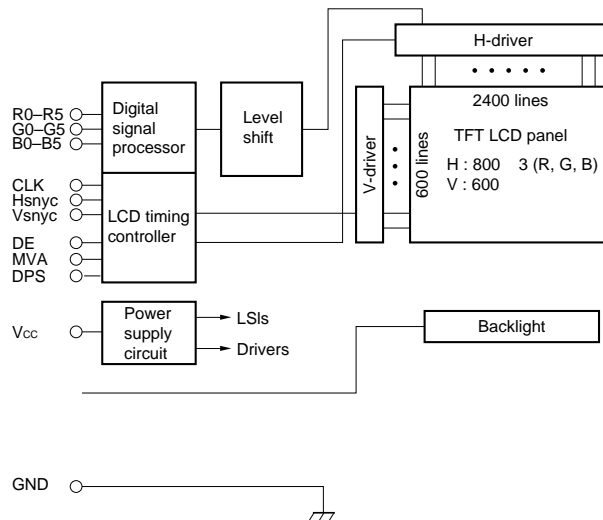

OUTLINE OF CHARACTERISTICS (at room temperature)

Display area	246.0 (H) 184.5 (V) mm
Drive system	a-Si TFT active matrix
Display colors	262144 colors
Number of pixels	800 600 pixels
Pixel arrangement	RGB vertical stripe
Pixel pitch	0.3075 (H) 0.3075 (V) mm
Module size	280.0 (H) 210.0 (V) 13.5 typ. (D) mm
Weight	700 g (typ.)
Contrast ratio	350:1 (typ.)
Viewing angle (more than the contrast ratio of 10:1)	Horizontal : 55° (typ. left side, right side) Vertical : 40° (typ. up side), 50° (typ. down side)
Designed viewing direction	<ul style="list-style-type: none"> • Wider viewing angle with contrast ratio : down side (6 o'clock) • Wider viewing angle without image reversal: up side (12 o'clock)
Color gamut	43 % (typ. center, to NTSC)
Response time	40 ms (max.), "white" to "black"
Luminance	350 cd/m ² (typ.)
Signal system	6-bit digital signals for each of RGB primary colors, synchronous signals (Hsync, Vsync), dot clock (CLK)
Supply voltage	3.3 V [5.0 V] (Logic, LCD driving)
Backlight	Edge light type, two cold cathode fluorescent lamps
Power consumption	TBD W (typ. at 3.3 V)

GENERAL SPECIFICATIONS

Item	Specification	Unit
Module size	280.0 ± 0.5 (H) 210.0 ± 0.5 (V) 13.7 max. (D)	mm
Inverter size	26.0 ± 0.5 (H) 125.0 $\begin{smallmatrix} +0.7 \\ -0.3 \end{smallmatrix}$ (V) 12.0 max. (D)	mm
Display area	246.0 (H) 184.5 (V)	mm
Number of pixels	800 (H) 600 (V)	pixel
Dot pitch	0.1025 (H) 0.3075 (V)	mm
Pixel pitch	0.3075 (H) 0.3075 (V)	mm
Pixel arrangement	RGB (Red, Green, Blue) vertical stripe	-
Display colors	262144	color
Weight	730 (max.)	g

ABSOLUTE MAXIMUM RATINGS

Parameter	Symbol	Rating	Unit	Remarks
Supply voltage	V _{CC}	3 to 6.5	V	V _I - V _{CC} < 3.0 T _a = 25°C
Input voltage	V _I	3 to 6.5	V	
Storage temp.	T _{ST}	0 to 60	°C	
Operating temp.	T _{OP}	0 to 50	°C	Module surface*
Humidity (No condensation)		≤ 95 % relative humidity		T _a ≤ 40°C
		≤ 85 % relative humidity		40 < T _a ≤ 50°C
		Absolute humidity shall not exceed T _a = 50°C, 85 % relative humidity level		T _a > 50°C

* Measured at the display area

ELECTRICAL CHARACTERISTICS

(1) Logic, LCD driving

T_a = 25°C

Parameter	Symbol	Min.	Typ.	Max.	Unit	Remarks
Supply voltage	V _{CC}	3.0 (4.75)	3.3 (5.0)	3.6 (5.25)	V	V _{CC} = 3.3 V (V _{CC} = 5.0 V)
Logic input "L" voltage	V _{IL}	0	-	V _{CC} 0.3	V	
Logic input "H" voltage	V _{IH}	V _{CC} 0.7	-	5.25	V	
Supply current	I _{CC}	-	*1 320 *1 (250)	² 600 ² (500)	mA	V _{CC} = 3.3 V (V _{CC} = 5.0 V)

*1. Checker flag pattern (in EIAJ ED-2522)

(2) Backlight

T_a = 25°C

Parameter	Symbol	Min.	Typ.	Max.	Unit	Remarks
Supply current	I _{DDb}	-	600	700	mA	350 cd/m ²
Supply voltage	V _{DDb}	11.4	12.0	12.6	Vrms	-

SUPPLY VOLTAGE SEQUENCE

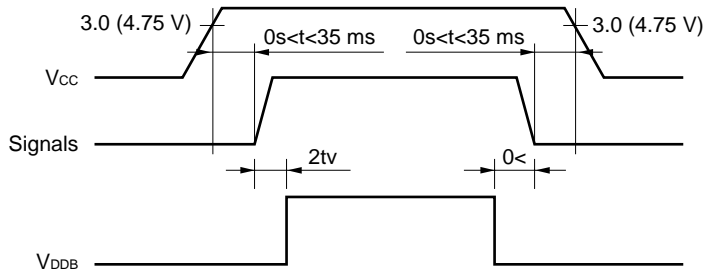

- *1 The supply voltage for input signals should be the same as V_{CC}.
- *2 Apply V_{DDb} within the LCD operation period. When the backlight turns on before LCD operation or the LCD operation turns off before the backlight turns off, the display may momentarily become white.
- *3 When the power is off, please keep whole signals (Hsync, Vsync, CLK, DE, data) low level or high impedance.

INTERFACE PIN CONNECTION

(1) Interface signals, power supply

Module side connector

CN1 ... DF9C-41P-1V (No. 1 to 41)

Supplier: HIROSE ELECTRIC CO., LTD.

or

Mating connector

DF9X-41S-1V (X: A,B or C) or DF9M-41S-1R

IL-310-T41S-VF

Supplier: Japan Aviation Electronics Industry limited (JAE)

note: Mating connectors are possible to use all parts.

Pin No.	Symbol	Function
1	GND	Ground
2	DCLK	Dot clock
3	GND	Ground
4	Hsync	Horizontal sync.
5	Vsync	Vertical sync.
6	GND	Ground
7	GND	Ground
8	GND	Ground
9	R0	Red data (LSB)
10	R1	Red data
11	R2	Red data
12	GND	Ground
13	R3	Red data
14	R4	Red data
15	R5	Red data (MSB)
16	GND	Ground
17	GND	Ground
18	GND	Ground
19	G0	Green data (LSB)
20	G1	Green data
21	G2	Green data

Pin No.	Symbol	Function
22	GND	Ground
23	G3	Green data
24	G4	Green data
25	G5	Green data (MSB)
26	GND	Ground
27	GND	Ground
28	GND	Ground
29	B0	Blue data (LSB)
30	B1	Blue data
31	B2	Blue data
32	GND	Ground
33	B3	Blue data
34	B4	Blue data
35	B5	Blue data (MSB)
36	GND	Ground
37	DE	Data enable Note 2
38	N.C.	Non-connection
39	Vcc	Power supply Note 1
40	Vcc	Power supply Note 1
41	DPS	Scan direction select Note 3

LSB : Least Significant Bit

MSB : Most Significant Bit

- Notes**
1. Vcc: All Vcc terminals should be connected to 3.3 V [5.0 V].
 2. DE: This function recognizes either Fixed or DE mode when Vsync rises.
 High or open = Fixed mode
 Low = DE mode
 3. DPS: DPS can change its scan direction.
 High = Reverse scan
 Low or open = Normal scan
 Refer to DISPLAY POSITION regarding to the scan direction.

(2) Backlight

Lamp side connector Mating connector
 CN2: BHR-03VS-1 SM03 (4.0) B-BHS-TB
 Supplier: J.S.T TRADING COMPANY, LTD.

Pin No.	Symbol	Function
1	VL	Backlight ground
2	VH	High voltage terminal
3	VH	High voltage terminal

Inverter side connector 1 Mating connector 1
 CN1: LZ-5P-SL-SMT LZ-5S-SC3
 Supplier: Japan Aviation Electronics Industry Limited (JAE)

Pin No.	Symbol	Function	Pin No.	Symbol	Function
1	V _{DD} B	Power supply	4	GNDB	Backlight ground
2	V _{DD} B	Power supply	5	BRTHL	Luminance select *1
3	GNDB	Backlight ground			

*1: High luminance (100 %): BRTHL = +5 V or open
 Low luminance (20 %): BRTHL = GND

Inverter side connector 2 Mating connector 2
 CN3: IL-Z-3PL-SMTY IL-Z-3S-S125C3
 Supplier: Japan Aviation Electronics Industry Limited (JAE)

Pin No.	Symbol	Function
1	BRTC	Backlight ON/OFF signal *1
2	BRTH	Luminance control input *2
3	BRTL	Luminance control input *2

*1: TTL level
 Backlight ON: BRTC = H (+5V) or Open
 Backlight OFF: BRTC = L (GNDB level)

*2: <1> A way of luminance control by a variable resistor
 This way works when BRTHL (No.5 pin) of CN1 is opened.

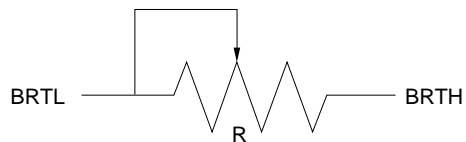

Mating variable resistor : 10 K ±5 %
 Minimum luminance (20 %) : R = 0
 Maximum luminance (100 %) : R = 10 K

<2> A way of luminance control by a voltage

This way works when BRTHL and BRTL are opened. The range of input voltage between BRTH and GNDB is as follows.

- Minimum luminance (20 %) : 3.4 V
- Maximum luminance (100 %) : ≤ 1.0 V

(3) Connector location

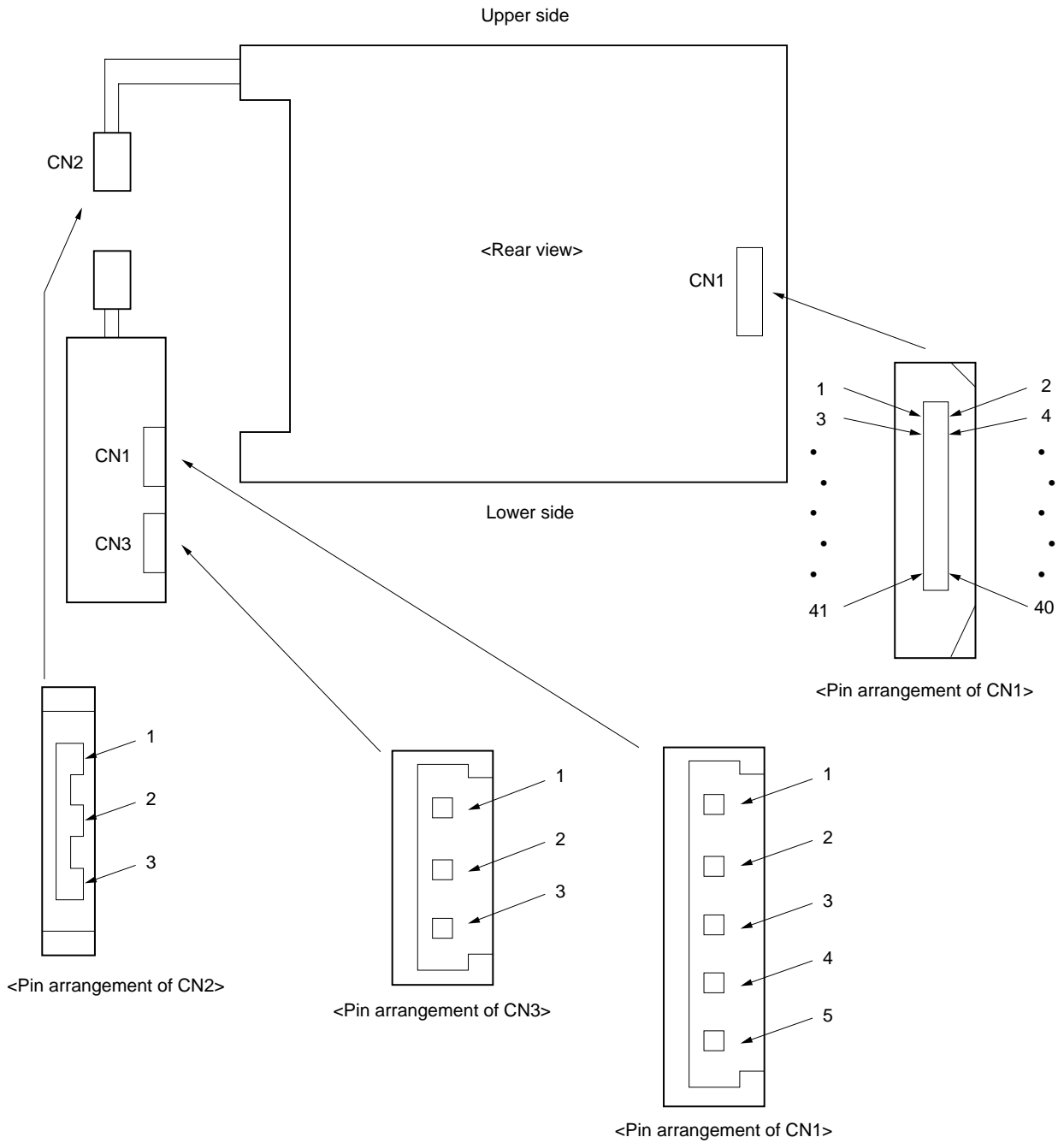

DISPLAY COLORS vs. INPUT DATA SIGNALS

Display colors		Data signal (0: Low level, 1: High level)																	
		R5	R4	R3	R2	R1	R0	G5	G4	G3	G2	G1	G0	B5	B4	B3	B2	B1	B0
Basic colors	Black	0	0	0	0	0	0	0	0	0	0	0	0	0	0	0	0	0	0
	Blue	0	0	0	0	0	0	0	0	0	0	0	0	1	1	1	1	1	1
	Red	1	1	1	1	1	1	0	0	0	0	0	0	0	0	0	0	0	0
	Magenta	1	1	1	1	1	1	0	0	0	0	0	0	1	1	1	1	1	1
	Green	0	0	0	0	0	0	1	1	1	1	1	1	0	0	0	0	0	0
	Cyan	0	0	0	0	0	0	1	1	1	1	1	1	1	1	1	1	1	1
	Yellow	1	1	1	1	1	1	1	1	1	1	1	1	0	0	0	0	0	0
	White	1	1	1	1	1	1	1	1	1	1	1	1	1	1	1	1	1	1
Red grayscale	Black	0	0	0	0	0	0	0	0	0	0	0	0	0	0	0	0	0	0
	Dark	0	0	0	0	0	1	0	0	0	0	0	0	0	0	0	0	0	0
	↑																		
	↓																		
	Bright	1	1	1	1	0	1	0	0	0	0	0	0	0	0	0	0	0	0
Red	1	1	1	1	1	1	0	0	0	0	0	0	0	0	0	0	0	0	
Green grayscale	Black	0	0	0	0	0	0	0	0	0	0	0	0	0	0	0	0	0	0
	Dark	0	0	0	0	0	0	0	0	0	0	0	1	0	0	0	0	0	0
	↑																		
	↓																		
	Bright	0	0	0	0	0	0	1	1	1	1	0	1	0	0	0	0	0	0
Green	0	0	0	0	0	0	1	1	1	1	1	0	0	0	0	0	0	0	
Blue grayscale	Black	0	0	0	0	0	0	0	0	0	0	0	0	0	0	0	0	0	0
	Dark	0	0	0	0	0	0	0	0	0	0	0	0	0	0	0	0	1	0
	↑																		
	↓																		
	Bright	0	0	0	0	0	0	0	0	0	0	0	0	1	1	1	1	0	1
Blue	0	0	0	0	0	0	0	0	0	0	0	0	1	1	1	1	1	0	
Blue	0	0	0	0	0	0	0	0	0	0	0	0	1	1	1	1	1	1	

Note Colors are developed in combination with 6-bit signals (64 steps in grayscale) of each primary red, green, and blue color.

This process can result in up to 262144 (64 × 64 × 64) colors.

INPUT SIGNAL TIMING

(1) Input signal specifications

Parameter		Symbol	Min.	Typ.	Max.	Unit	Remarks
CLK	Frequency	1/tc	34.0	38.362	40.0	MHz	26.067 ns (TYP.)
	Duty	tch/tc	0.4	0.5	0.6	-	
	Rise, fall	tcrf	-	-	10	ns	
Hsync	Period	th	24.3	26.693	-	s	37.463 kHz (TYP.)
			829	1024	-	CLK	
	Display period	thd	800			CLK	
	Front-porch	thf	24			CLK	fixed timing mode
			4	24	-	CLK	DE mode
	Pulse width	thp*	1	72	127	CLK	fixed timing mode
			1	72	-	CLK	DE mode
	Back-porch	thb*	73	128	198	CLK	fixed timing mode
			13	128	509	CLK	DE mode
	thp + thb*		200			CLK	fixed timing mode
			25	200	511	CLK	DE mode
	CLK-Hsync timing	thch	10	-	-	ns	
	Hsync-CLK timing	thcs	8	-	-	ns	
	Hsync-Vsync timing	tvhh	1	-	-	CLK	
	Vsync-Hsync timing	tvhs	15	-	-	ns	
Rise, fall	thrf	-	-	10	ns		
Vsync	Period	tv	16.1	16.683	17.2	ms	59.94 Hz (TYP.)
			603	625	-	H	
	Display period	tvd	600			H	
	Front-porch	tvf	1			H	fixed timing mode
			1	1	-	H	DE mode
	Pulse width	tvp*	1	2	23	H	fixed timing mode
			1	2	-	H	DE mode
	Back-porch	tvb*	1	22	23	H	fixed timing mode
			1	22	-	H	DE mode
	tvp + tvb*		24			H	fixed timing mode
		2	24	254	H	DE mode	
Rise, fall	tvrf	-	-	10	ns		
DATA R0 - R5 G0 - G5 B0 - B5	CLK-DATA timing	tds	8	-	-	ns	
	DATA-CLK timing	tdh	10	-	-	ns	
	Rise, fall	tdrf	-	-	10	ns	
DE	DE-CLK timing	tes	8	-	-	ns	DE mode
	CLK-DE timing	teh	10	-	-	ns	
	Rise, fall	terf	-	-	10	ns	

All of parameters should be kept in the specified range.

(2) Definition of input signal timing

<Vertical>

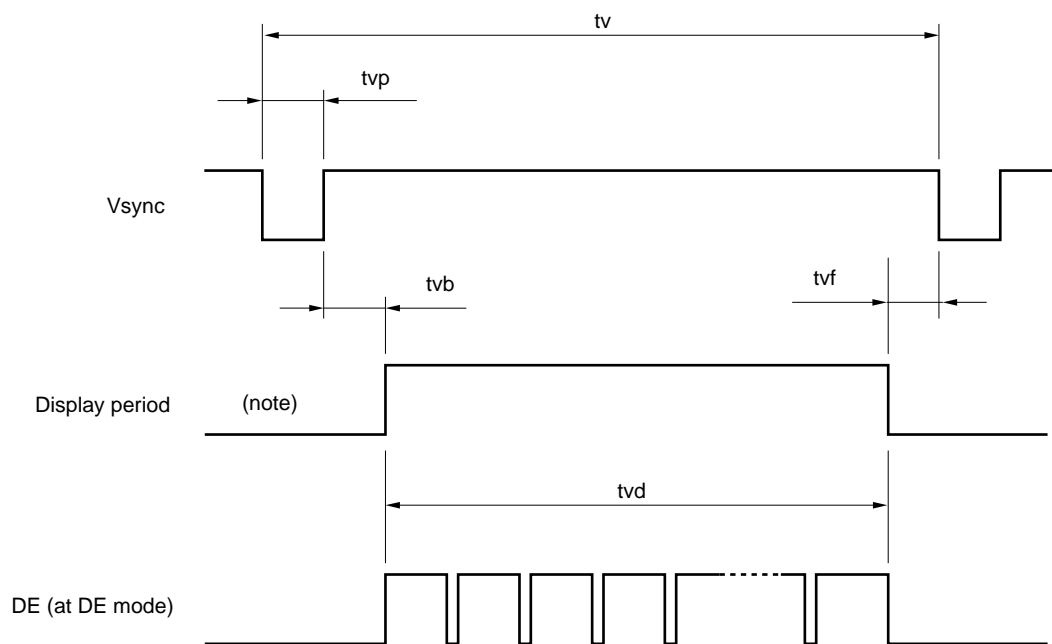

<Horizontal>

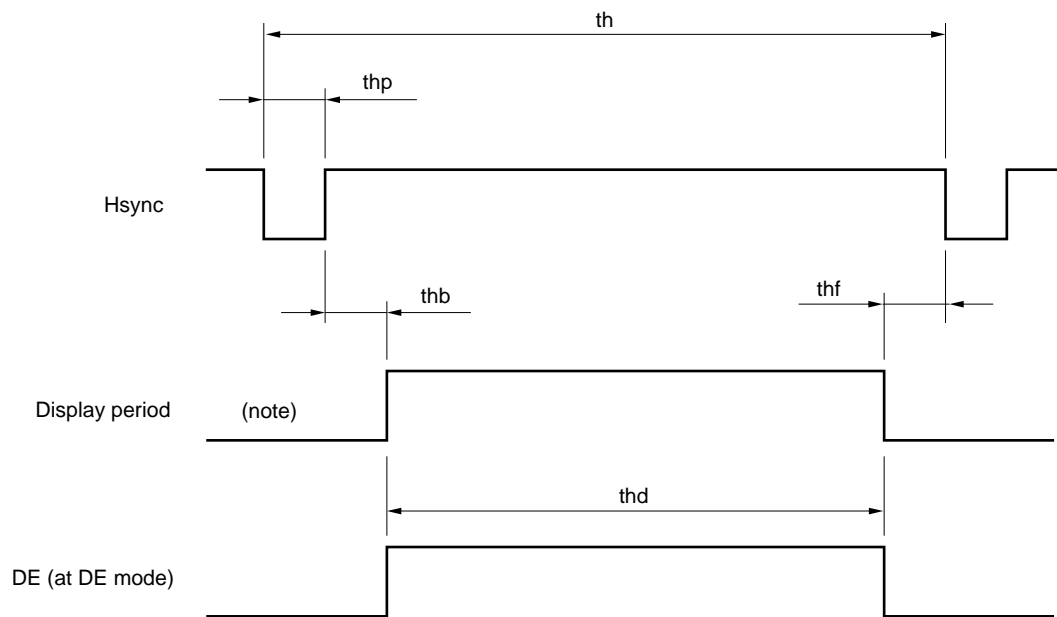

Note These do not exist as signals.

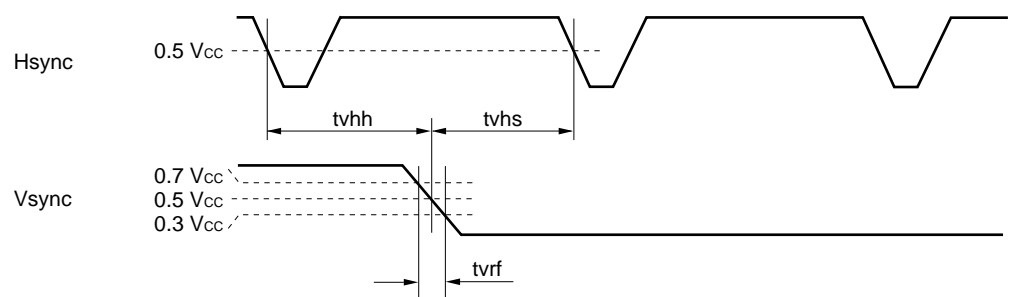
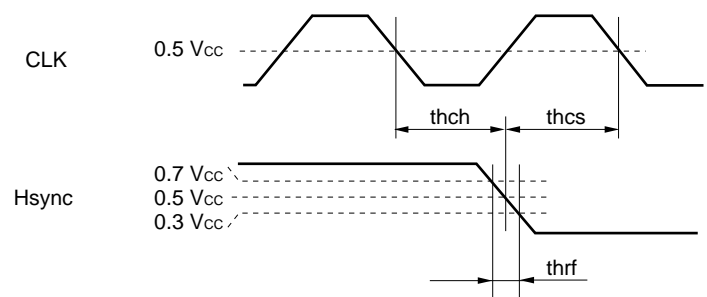
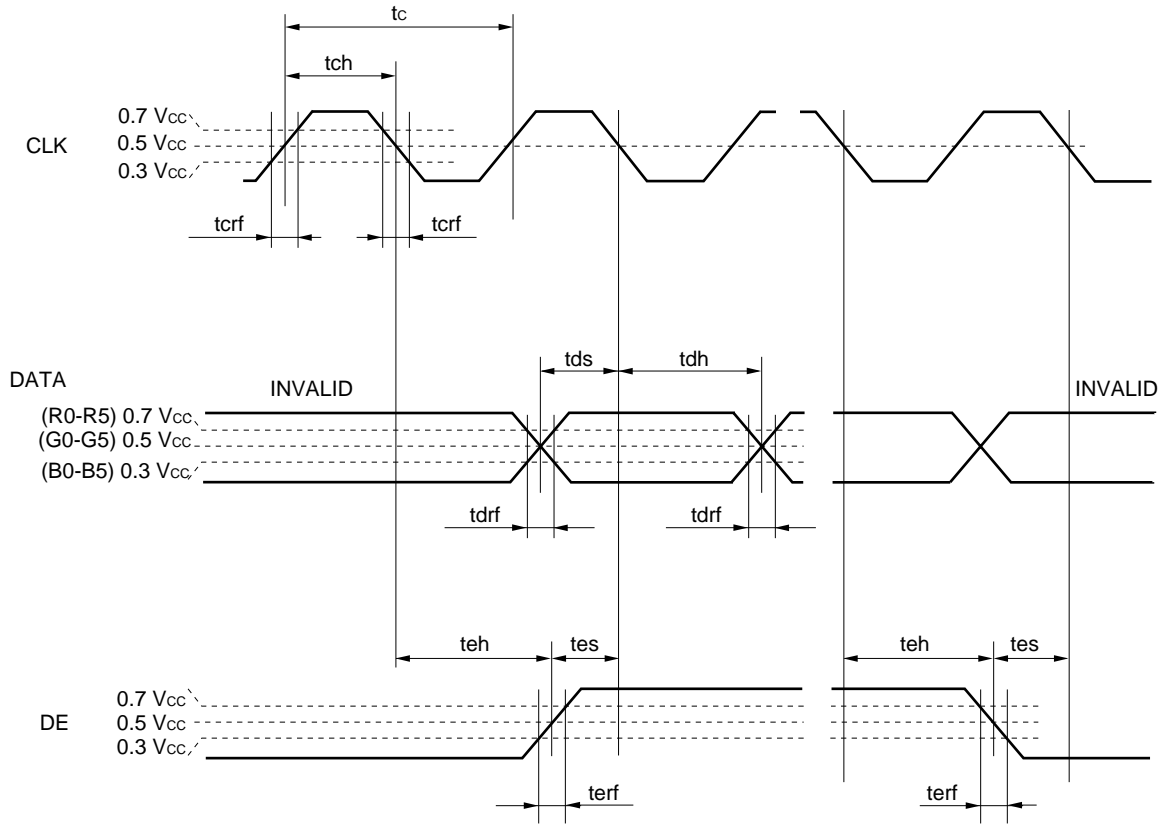

(3) Input signal timing chart

a) Fixed timing mode

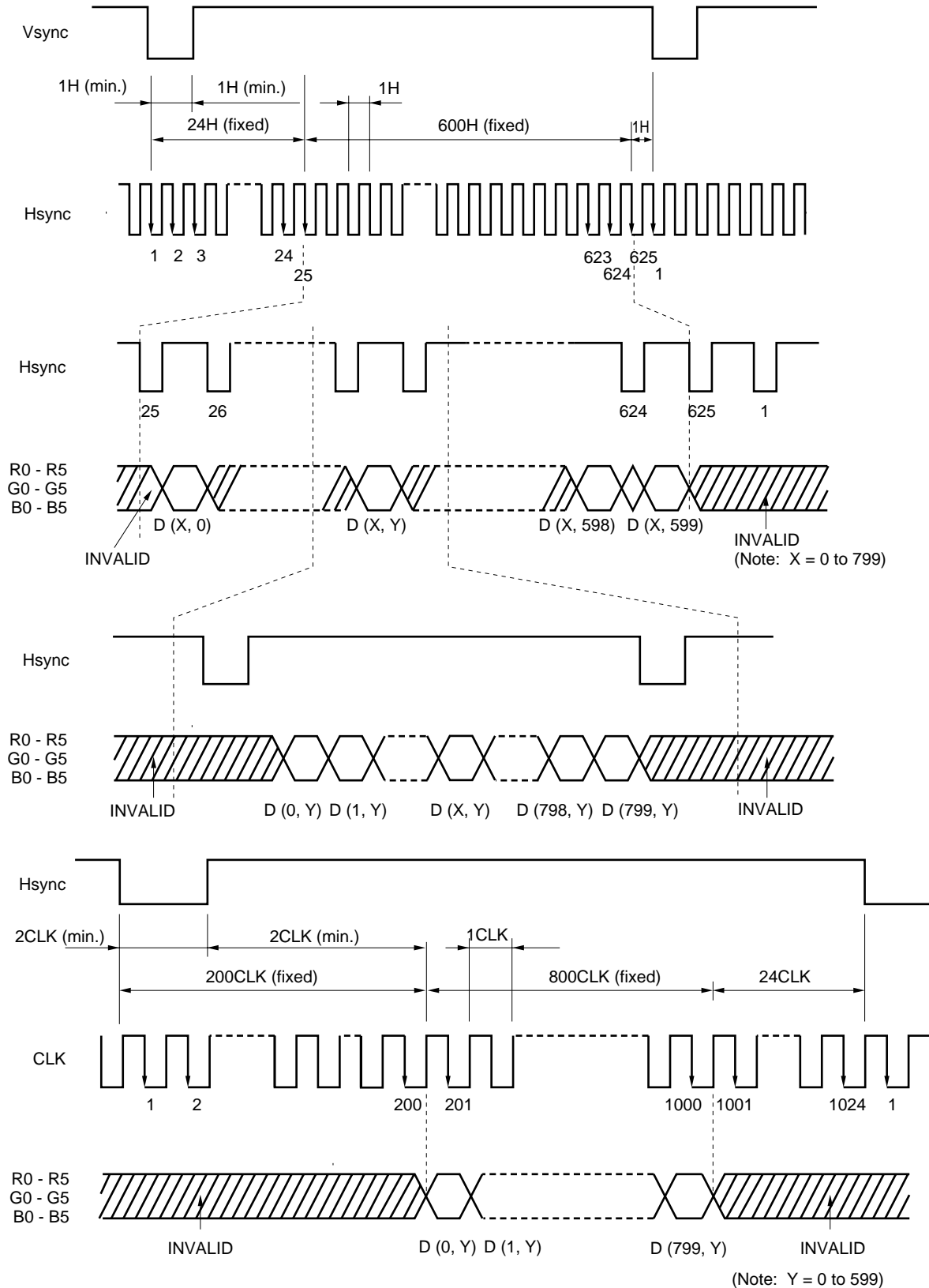

b) DE mode

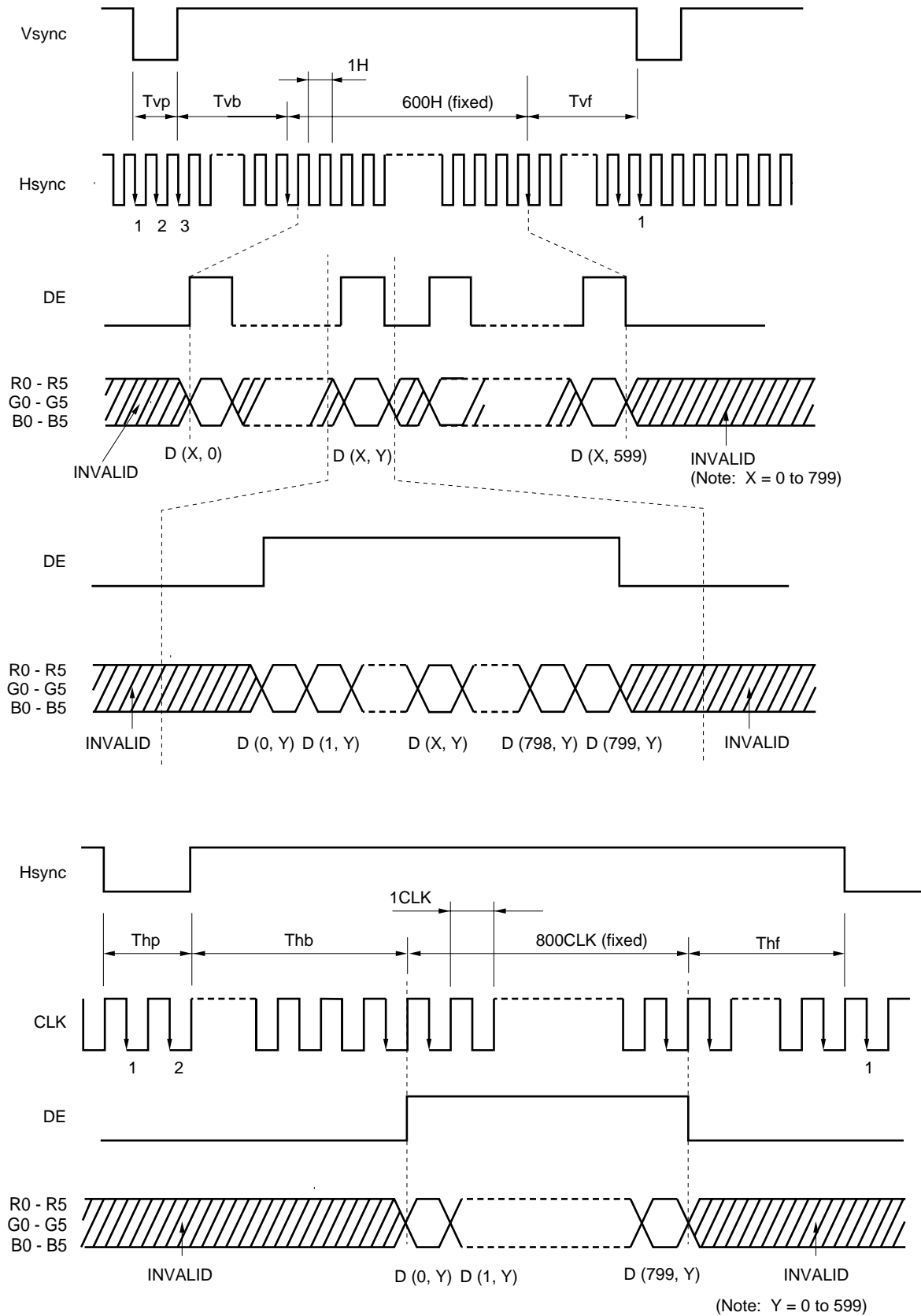

(4) Display position

Normal scan (DPS = Low or Open)

D (0, 0)	D (1, 0)	-----	D (X, 0)	-----	D (798, 0)	D (799, 0)
D (0, 1)	D (1, 1)	-----	D (X, 1)	-----	D (798, 1)	D (799, 1)
⋮	⋮	-----	⋮	-----	⋮	⋮
D (0, Y)	D (1, Y)	-----	D (X, Y)	-----	D (798, Y)	D (799, Y)
⋮	⋮	-----	⋮	-----	⋮	⋮
D (0, 598)	D (1, 598)	-----	D (X, 598)	-----	D (798, 598)	D (799, 598)
D (0, 599)	D (1, 599)	-----	D (X, 599)	-----	D (798, 599)	D (799, 599)

Reverse scan (DPS = High "Vcc")

D (799, 599)	D (798, 599)	---	D (X, 599)	---	D (1, 599)	D (0, 599)
D (799, 598)	D (798, 598)	---	D (X, 598)	---	D (1, 598)	D (0, 598)
⋮	⋮	---	⋮	---	⋮	⋮
D (799, Y)	D (798, Y)	---	D (X, Y)	---	D (1, Y)	D (0, Y)
⋮	⋮	---	⋮	---	⋮	⋮
D (799, 1)	D (798, 1)	---	D (X, 1)	---	D (1, 1)	D (0, 1)
D (799, 0)	D (798, 0)	---	D (X, 0)	---	D (1, 0)	D (0, 0)

Note 1. Below drawings shows relation between the scan direction and viewing direction.

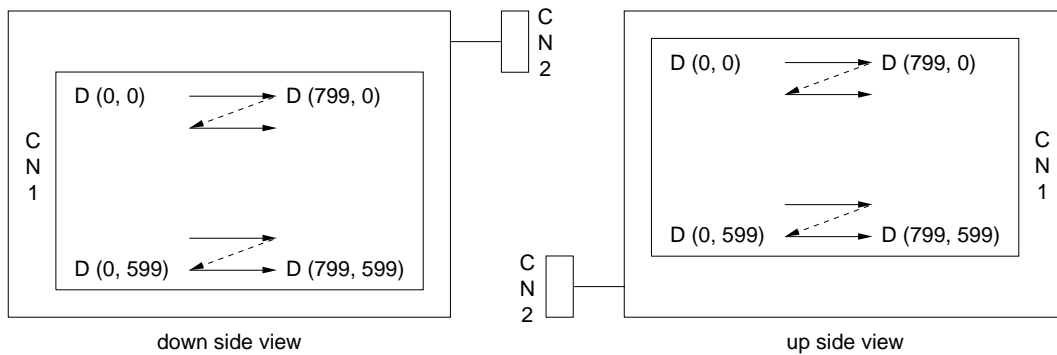

OPTICAL CHARACTERISTICS

T_a = 25 ± 5°C, V_{CC} = 3.3V, V_{DB} = 12V, MVA = V_{CC} or open, at normal scan

Parameter	Symbol	Condition	MIN.	TYP.	MAX.	Unit	
Luminance	LVMAX	X = ±0°, Y = ±0°, at center	280	350	–	cd/m ²	
Contrast ratio	CR	X = ±0°, Y = ±0°, at center	200	350	–	–	
Viewing angle range	Horizontal	X+	CR > 10, Y = ±0°	45	55	–	deg.
		X–	CR > 10, Y = ±0°	45	55	–	deg.
	Vertical	Y+	CR > 10, X = ±0°	30	40	–	deg.
		Y–	CR > 10, X = ±0°	40	50	–	deg.
Color gamut	C	at center, to NTSC	35	43	–	%	
Response time	ton	White to black	–	–	40	ms	
	toff	Black to white	–	60	80		
Brightness uniformity	–	Maximum luminance	–	–	1.40	–	
		Minimum luminance					

Remarks 1. The contrast ratio is calculated by using the following formula.

$$\text{Contrast ratio (CR)} = \frac{\text{Luminance with all pixels in white}}{\text{Luminance with all pixels in black}}$$

The Luminance is measured in darkroom.

2. Definitions of viewing angle are as follows.

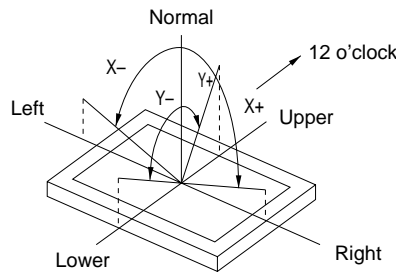

3. The luminance is measured after 20 minutes from the module works, with all pixels in white. Typical value is measured after luminance saturation.

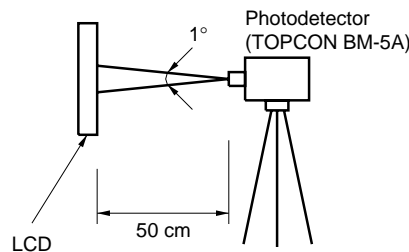

4. Definition of response time is as follows.

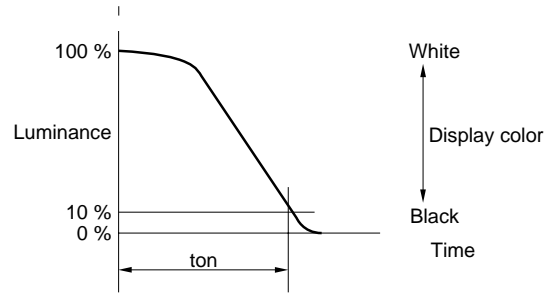

5. The luminance is measured at near the five points shown below.

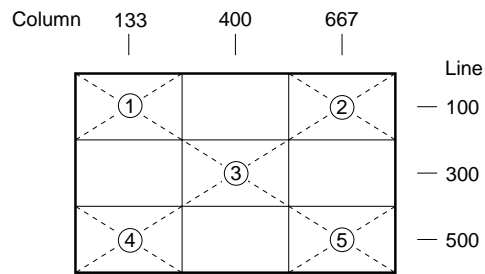

OUTLINE DRAWING

REAR SIDE (Unit in mm)

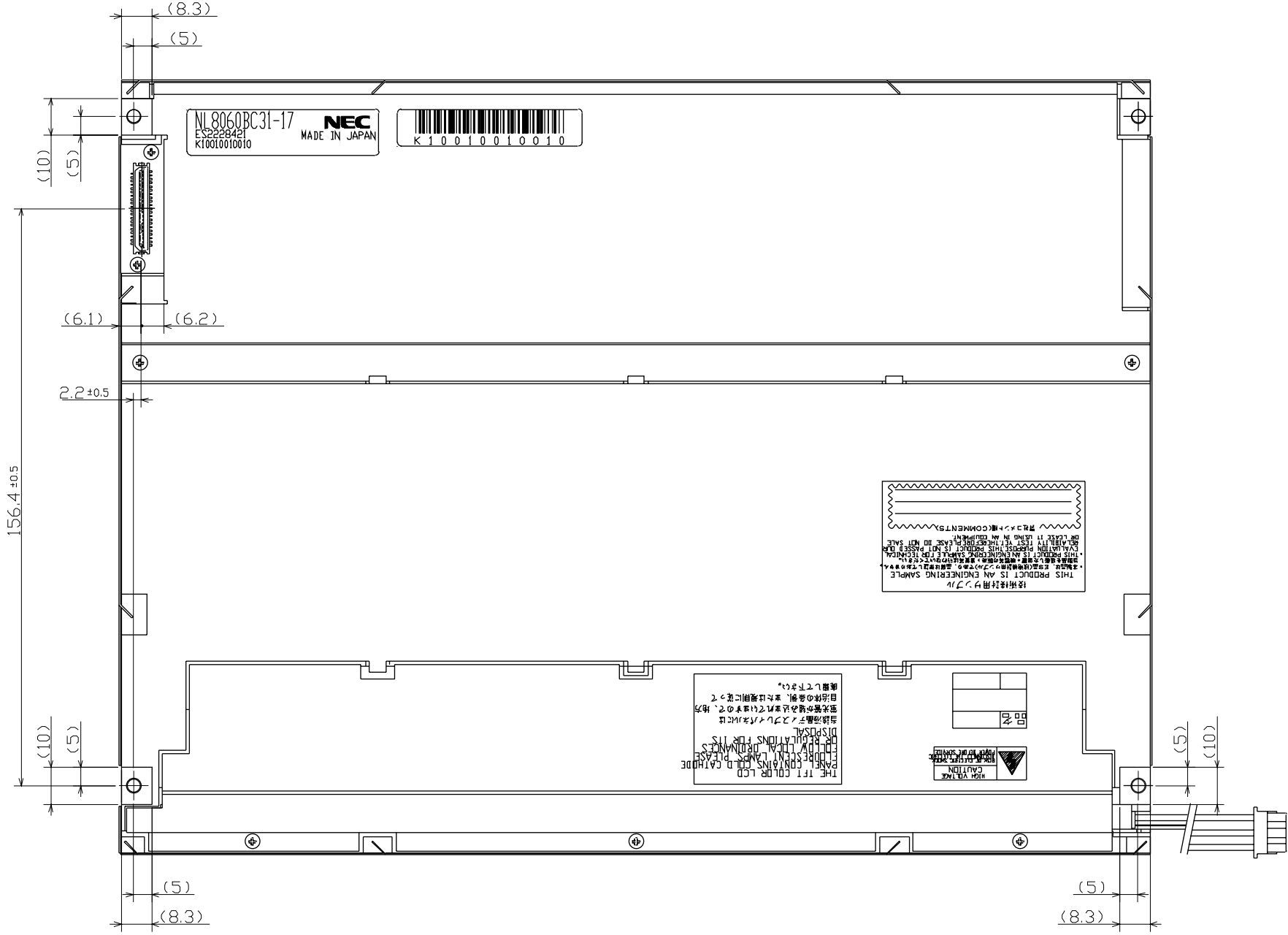

GENERAL CAUTIONS

Next figures and sentence are very important. Please understand these contents as follows.

	CAUTION	This figure is a mark that you will get hurt and/or the module will have damages when you make a mistake to operate.
---	----------------	--

		This figure is a mark that you will get an electric shock when you make a mistake to operate.
---	--	---

		This figure is a mark that you will get hurt when you make a mistake to operate
---	--	---

 **CAUTION**

	Do not touch an inverter, on which is stuck a caution label, while the LCD module is under the operation, because of dangerous high voltage.
---	--

- (1) Caution when taking out the module
 - a) Pick the pouch only, in taking out module from a carrier box.

- (2) Cautions for handling the module
 - a) As the electrostatic discharges may break the LCD module, handle the LCD module with care against electrostatic discharges.
 - b)  As the LCD panel and backlight element are made from fragile glass material, impulse and pressure to the LCD module should be avoided.
 - c) As the surface of polarizer is very soft and easily scratched, use a soft dry cloth without chemicals for cleaning.
 - d) Do not pull the interface connectors in or out while the LCD module is operating.
 - e) Put the module display side down on a horizontal plane.
 - f) Handle connectors and cables with care.
 - g) When the module is operating, do not lose CLK, Hsync or Vsync signal. If any one of these signals is lost, the LCD panel would be damaged.
 - h) The torque to mounting screw should never exceed 0.294 N·m (3 kgf·cm).

- (3) Cautions for the atmosphere
 - a) Dew drop atmosphere should be avoided.
 - b) Do not store and/or operate the LCD module in a high temperature and/or high humidity atmosphere. Storage in an electro-conductive polymer packing pouch and under relatively low temperature atmosphere is recommended.
 - c) This module uses cold cathod fluorescent lamp. Therefore, the life time of lamp becomes short conspicuously at low temperature.
 - d) Do not operate the LCD module in a high magnetic field.

- (4) Caution for the module characteristics
 - a) Do not apply fixed pattern data signal for a long time to the LCD module. It may cause image sticking. Please use screen savers if the display pattern is fixed more than one hour.

(5) Other cautions

- a) Do not disassemble and/or reassemble LCD module.
- b) Do not readjust variable resistors etc.
- c) When returning the module for repair or etc, please pack the module not to be broken. We recommend to the original shipping packages.

Liquid Crystal Display has the following specific characteristics. There are not defects or malfunctions.

- The display condition of LCD module may be affected by the ambient temperature.
- The LCD module uses cold cathode tube for backlighting. Optical characteristics, like luminance or uniformity, will change during time.
- Uneven brightness and/or small spots may be noticed depending on different display patterns.

No part of this document may be copied or reproduced in any form or by any means without the prior written consent of NEC Corporation. NEC Corporation assumes no responsibility for any errors which may appear in this document.

NEC Corporation does not assume any liability for infringement of patents. Copyrights or other intellectual property rights of third parties by or arising from use of a device described herein or any other liability arising from use of such device. No license, either express, implied or otherwise, is granted under any patents, copyrights or other intellectual property rights of NEC Corporation or others.

While NEC Corporation has been making continuous effort to enhance the reliability of its Electronic Components, the possibility of defects cannot be eliminated entirely. To minimize risks of damage or injury to persons or property arising from a defect in an NEC Electronic Components, customers must incorporate sufficient safety measures in its design, such as redundancy, fire-containment, and anti-failure features.

NEC devices are classified into the following three quality grades:

“Standard”, “Special”, and “Specific”. The Specific quality grade applies only to devices developed based on a customer designated “quality assurance program” for a specific application. The recommended applications of a device depend on its quality grade, as indicated below. Customers must check the quality grade of each device before using it in a particular application.

Standard: Computers, office equipment, communications equipment, test and measurement equipment, audio and visual equipment, home electronic appliances, machine tools, personal electronic equipment and industrial robots

Special: Transportation equipment (automobiles, trains, ships, etc.), traffic control systems, anti-disaster systems, anti-crime systems, safety equipment and medical equipment (not specifically designed for life support)

Specific: Aircrafts, aerospace equipment, submersible repeaters, nuclear reactor control systems, life support systems or medical equipment for life support, etc.

The quality grade of NEC devices is “Standard” unless otherwise specified in NEC’s Data Sheets or Data Books.

If customers intend to use NEC devices for applications other than those specified for Standard quality grade, they should contact an NEC sales representative in advance.

Anti-radioactive design is not implemented in this product.