

201U1LW28

The device listed in these specification sheets was designed and manufactured for use in OA equipment.

In case of using the device for applications such as control and safety equipment for transportation (aircraft, trains, automobiles, etc.), rescue and security equipment and various safety related equipment which require higher reliability and safety, take into consideration that appropriate measures such as fail-safe functions and redundant system design should be taken.

In case of using the device for equipment that requires an extreme level of reliability, such as aerospace applications, telecommunication equipment (trunk lines), nuclear power control equipment and medical or other equipment for life support, contact and consult with a SHARP sales representative.

SHARP assumes no responsibility for any damage resulting from the use of the device which does not comply with the instructions and the precautions specified in these specification sheets.

Contact and consult with a SHARP sales representative for any questions about this device.

2. Overview

This module is a color active matrix LCD module incorporating amorphous silicon TFT (Thin Film Transistor). It is composed of a color TFT-LCD panel, driver ICs, control circuit, power supply circuit and a back light unit. Graphics and texts can be displayed on a 1600 × 3 × 1200 dots panel with about 16 million colors by supplying 48 bit data signals (8bit × 2pixel × RGB), two display enable signals, two dot clock signals, +12V DC supply voltages for TFT-LCD panel driving and supply voltage for back light.

It is a wide viewing-angle-module (Vertical viewing angle: 176 ° Horizontal viewing angle: 176 °, CR 10). This module performance achieve 20ms response time (full; black to white, or white to black) done by improving Liquid crystal material.

3. Mechanical Specifications

Parameter	Specifications	Unit
Display size	51 (Diagonal)	cm
	20.1 (Diagonal)	Inch
Active area	408.0 (H) × 306.0 (V)	mm
Pixel format	1600 (H) × 1200 (V)	Pixel
	(1 pixel = R + G + B dots)	
Pixel pitch	0.255(H) × 0.255 (V)	mm
Pixel configuration	R,G,B vertical stripe	
Display mode	Normally black	
Unit outline dimensions	432(W) × 331.5 (H) × 25 (D)	mm
Mass	3.2 (Typ)	kg
Surface treatment	Anti-glare And hard-coating 3H	

Outline dimensions are shown in Fig.1.

4. Input Terminals and Function

4-1. TFT-LCD panel driving

LVDS interface with 2 input signal, and +12VDC power supply, control signal

Connectors : (MDF76LARW-30S-1H(HIROSE))

Corresponding connectors : FI-X30M(JAE)

LVDS receiver : Contained in a control IC

Corresponding LVDS transmitter : THC63LVDM83R(Thine) or compatible

Pin No.	Symbol	Function	Remark
1	Vcc	+12V power supply	
2	Vcc	+12V power supply	
3	Vcc	+12V power supply	
4	Vcc	+12V power supply	
5	Vss	Gnd	
6	Vss	Gnd	
7	RBIN3+	Positive (+) LVDS differential data input (B port)	LVDS
8	RBIN3-	Negative (-) LVDS differential data input (B port)	LVDS
9	CKBIN+	Positive (+) LVDS differential clock input (B port)	LVDS
10	CKBIN-	Negative (-) LVDS differential clock input (B port)	LVDS
11	RBIN2+	Positive (+) LVDS differential data input (B port)	LVDS
12	RBIN2-	Negative (-) LVDS differential data input (B port)	LVDS
13	RBIN1+	Positive (+) LVDS differential data input (B port)	LVDS
14	RBIN1-	Negative (-) LVDS differential data input (B port)	LVDS
15	RBIN0+	Positive (+) LVDS differential data input (B port)	LVDS
16	RBIN0-	Negative (-) LVDS differential data input (B port)	LVDS
17	Vss	Gnd	
18	Vss	Gnd	
19	RAIN3+	Positive (+) LVDS differential data input (A port)	LVDS
20	RAIN3-	Negative (-) LVDS differential data input (A port)	LVDS
21	CKAIN+	Positive (+) LVDS differential clock input (A port)	LVDS
22	CKAIN-	Negative (-) LVDS differential clock input (A port)	LVDS
23	RAIN2+	Positive (+) LVDS differential data input (A port)	LVDS
24	RAIN2-	Negative (-) LVDS differential data input (A port)	LVDS
25	RAIN1+	Positive (+) LVDS differential data input (A port)	LVDS
26	RAIN1-	Negative (-) LVDS differential data input (A port)	LVDS
27	RAIN0+	Positive (+) LVDS differential data input (A port)	LVDS
28	RAIN0-	Negative (-) LVDS differential data input (A port)	LVDS
29	Vss	Gnd	
30	Vss	Gnd	

【Note1】 This module has dual pixel port to receive dual pixel data at the same time . A port receives first pixel data and B port receives second pixel data in dual pixel data.

【Note2】 Thine:THC63LVDM83R

Transmitter		Data arrangement
Pin No	Data	
51	TA0	R0(LSB)
52	TA1	R1
54	TA2	R2
55	TA3	R3
56	TA4	R4
3	TA5	R5
4	TA6	G0(LSB)
6	TB0	G1
7	TB1	G2
11	TB2	G3
12	TB3	G4
14	TB4	G5
15	TB5	B0(LSB)
19	TB6	B1
20	TC0	B2
22	TC1	B3
23	TC2	B4
24	TC3	B5
27	TC4	(NA)
28	TC5	(RSV1)
30	TC6	DE
50	TD0	R6
2	TD1	R7(MSB)
8	TD2	G6
10	TD3	G7(MSB)
16	TD4	B6
18	TD5	B7(MSB)
25	TD6	(NA)

4-2 Interface block diagram

LVDS receiver : Contained in a control IC.

Applied Transmitter : THC63LVDM83R(THine electronics), or equivalent: DS90C383,DS90C383A(National semiconductor)

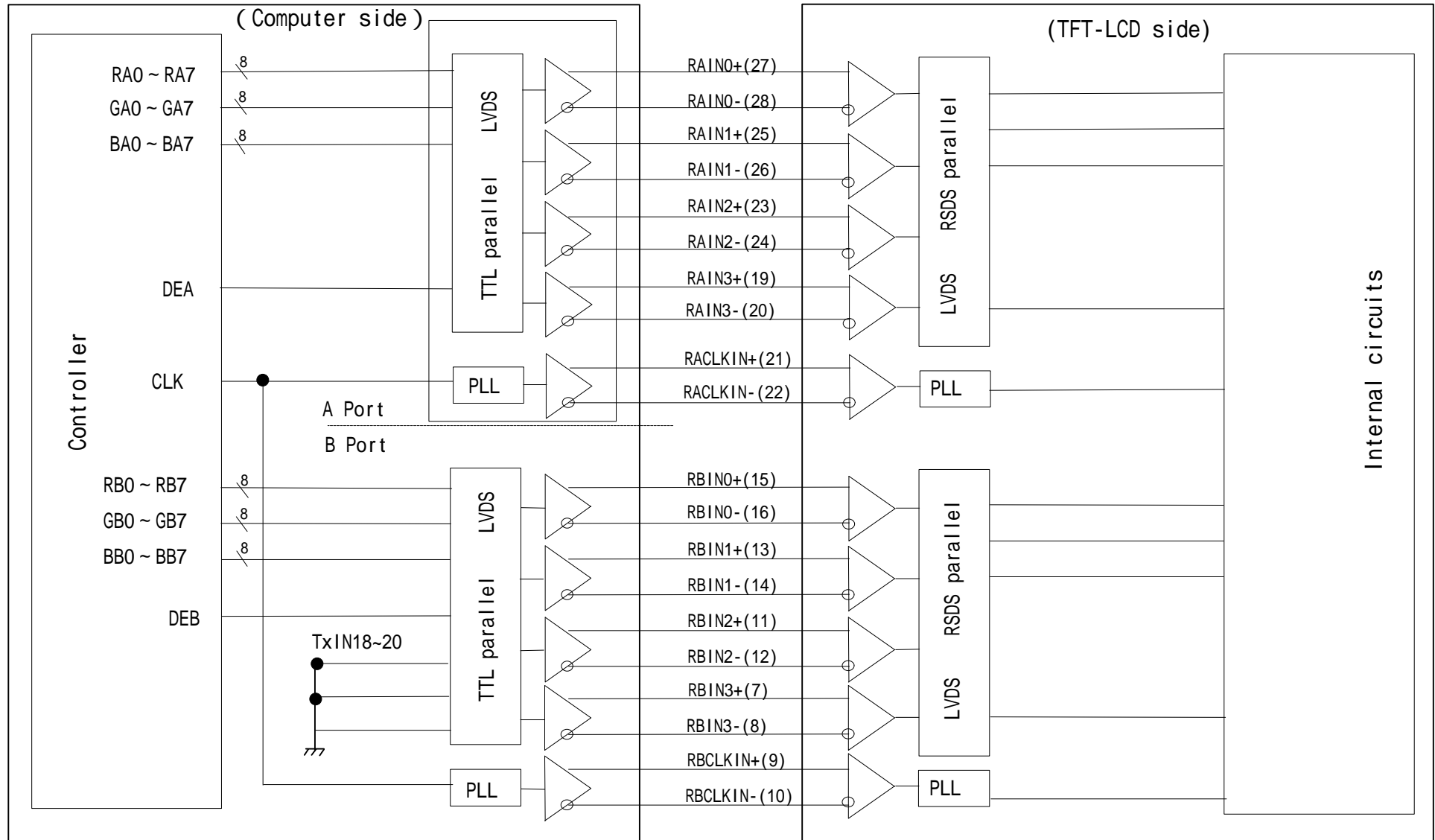

4-2. Back light driving

CN1, 3 (High voltage side)

The module-side connector : XHP - 7 (JST)
 The user-side connector : S7B - XH - A (JST)
 Cable : UL Style No. : 10267
 rated voltage : 2kV (AC)
 AWG : 26

Pin no.	symbol	Function	Cable color
1	V _{H-1}	Power supply for lamp 1 (High voltage side)	Pink
2	NC	This is electrically opened.	
3	NC	This is electrically opened.	
4	V _{H-2}	Power supply for lamp 2 (High voltage side)	Blue
5	NC	This is electrically opened.	
6	NC	This is electrically opened.	
7	V _{H-3}	Power supply for lamp 3 (High voltage side)	Orange

CN 2,4(Low voltage side)

The module-side connector : BHR - 03VS - 1 (JST)
 The user-side connector : SM03(4.0)B - BHS - 1 - TB (JST)
 Cable : UL Style No. : 10368
 rated voltage : 300V (AC)
 AWG : 26

Pin no.	symbol	Function	Cable color
1	V _{L-1}	Power supply for lamp 1 (Low voltage side)	White
2	V _{L-2}	Power supply for lamp 2 (Low voltage side)	Gray
3	V _{L-3}	Power supply for lamp 3 (Low voltage side)	Brown

The pair of CN1 and CN2 is for the same CCFT lamps. The pair of CN3 and CN4 is in the same way.

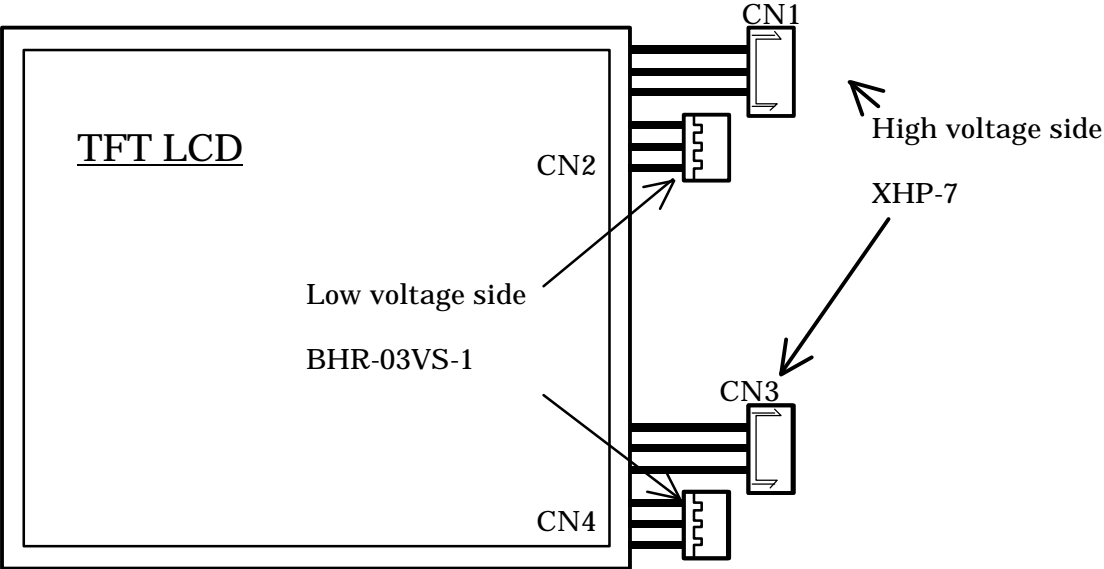

5. Absolute Maximum Ratings

Parameter	Symbol	Condition	Ratings	Unit	Remark
+12.0V supply voltage	Vcc	Ta=25	0 ~ +14.0	V	
Storage temperature	Tstg	-	-25 ~ +60		【Note1】
Operating temperature (Ambient)	Topa	-	0 ~ +50		

【Note1】 Humidity : 95%RH Max. (Ta 40)
 Maximum wet-bulb temperature at 39 or less. (Ta>40)
 No condensation.

6. Electrical Characteristics

6-1. TFT-LCD panel driving

Ta = 25

Parameter	Symbol	Min.	Typ.	Max.	Unit	Remark
Vcc	Supply voltage	+10.8	+12.0	+13.2	V	【Note1】
	Current dissipation	Icc	420	600	mA	【Note2】
	Rush Current			3	A	【Note3】
Permissive input ripple voltage	V _{RF}	-	-	100	mVp-p	

【Note1】

1) On-off sequences of Vcc and data

- 0 < t1 60ms
- 0 < t2 10ms
- 0 < t3 1s
- t4 100ms

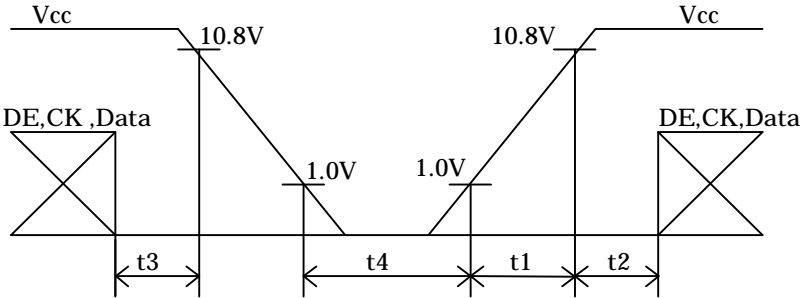

2) Dip conditions for supply voltage

- V_{min}, V_{th} = 10.8V, 9.6V
- 1) V_{th} < Vcc < V_{min}
t_d 20ms
- 2) Vcc < V_{th}
The LCD module shuts down.

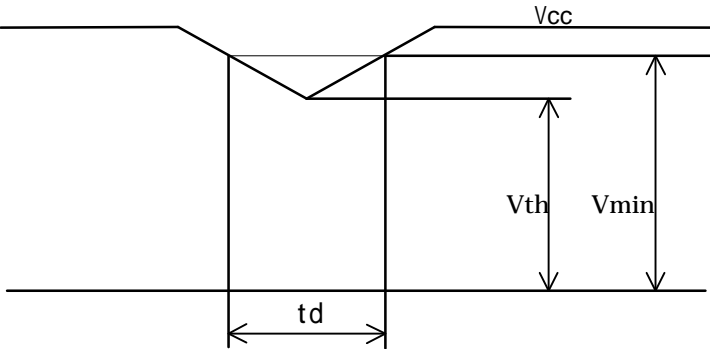

【Note2】 Typical current situation : 256-gray-bar pattern

Vcc = +12.0V
 The explanation of each gray scale ,GS,
 is described below section 8.

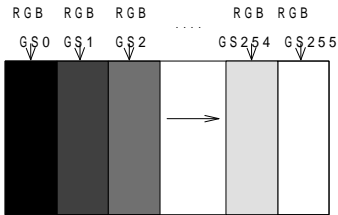

【Note3】 The duration of rush current is about 1ms.

6-2. Back light driving

The back light system is an edge-lighting type with 6 CCFTs (Cold Cathode Fluorescent Tube).

The characteristics of the lamp are shown in the following table.

The value mentioned below is at the case of one CCFT.

CCFT Model Name : KTBE222MSTF-421MA77-Z (STANLEY.ELECTRIC.CO.,LTD)

Parameter	Symbol	Min.	Typ.	Max.	Unit	Remark
Lamp current range	I_L	3	6	7	mArms	【Note1】
Lamp voltage	V_L		800	900	Vrms	$T_a=25$ $I_L=6.0mA_{rms}$ $F_L=60kHz$
Lamp power consumption	P_L		4.8	5.4	W	【Note2】 $I_L=6.0mA_{rms}$ $F_L=60kHz$
Lamp frequency	F_L	35	60	70	KHz	【Note3】
Kick-off voltage	V_s			1800	Vrms	$T_a=25$ 【Note4】
				2000	Vrms	$T_a=0$ 【Note4】
Lamp life time	T_L	50,000			Hour	【Note5】

【Note1】 A lamp can be light in the range of lamp current shown above.

Maximum rating for current is measured by high frequency current measurement equipment connected to V_{LOW} at circuit showed below.

(Note : To keep enough kick-off voltage and necessary steady voltage for CCFT.)

Lamp frequency : 35 ~ 70kHz

Ambient temperature : 0 ~ 50

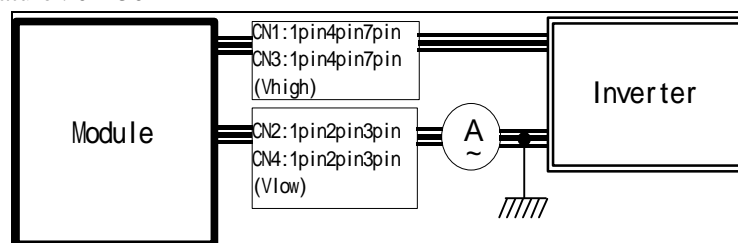

【Note2】 Referential data per one CCFT by calculation ($I_L \times V_L$).

The data doesn't include loss at inverter .

【Note3】 Lamp frequency of inverter may produce interference with horizontal synchronous frequency, and this may cause horizontal beat on the display. Therefore, adjust lamp frequency, and keep inverter as far as from module or use electronic shielding between inverter and module to avoid interference.

【Note4】 It is defined at 27pF for the ballast capacitor of a DC-AC inveter.

The Kick-off voltage may rise up in the user set, please decide the open output voltage by checking not to occur lighting failure under operating state.

The open output voltage should be applied to the lamp for more than 1 second to startup. Or when the ambient luminance around the lamp is more than 1lux, it should be applied to the lamp for more than 100ms. Otherwise the lamp may not be turned on..

【Note5】 Lamp life time is defined as the time when either or occurs in the continuous operation under the condition of $T_a=25$ and $I_L=6.0$ mArms .

Brightness becomes 50% of the original value under standard condition.

Kick-off voltage at $T_a=0$ exceeds maximum value, 2000Vrms .

《Note》

The performance of the backlight, for example lifetime or brightness, is much influenced by the characteristics of the DC-AC inverter for the lamp. When you design or order the inverter, please make sure that a poor lighting caused by the mismatch of the backlight and the inverter (miss-lighting, flicker, etc.) never occurs. When you confirm it, the module should be operated in the same condition as it is installed in your instrument.

Use the lamp inverter power source incorporating such safeguard as overvoltage / overcurrent protective circuit or lamp voltage waveform detection circuit, which should have individual control of each lamp.

In case one circuit without such individual control is connected to more than two lamps, excessive current may flow into one lamp when the other one is not in operation.

Synchronize frequency and phase of CCFT in the same connector. Otherwise it may exceed rated voltage of connector.

7. Timing characteristics of input signals

7-1-1. Timing characteristics

	Parameter	Symbol	Min.	Typ.	Max.	Unit	Remark
Clock	Frequency	1/Tc	60.0	81.0	85.0	MHz	
	Skew	Tcsq	-4	0	4	ns	【Note1】
Data enable signal	Horizontal period	TH	830	1080	1317	clock	
			10.0	13.3	15.5	μs	
	Horizontal period (High)	THd	800	800	800	clock	
	Vertical period	TV	1205	1250	2000	line	【Note2】
			12.1	16.7	-	ms	
Vertical period (High)	TVd	1200	1200	1200	line		

【Note1】 Lvds (A port)– Lvds (B port) phase difference

【Note2】 In case of using the long vertical period, the deterioration of display quality, flicker etc. may occur.

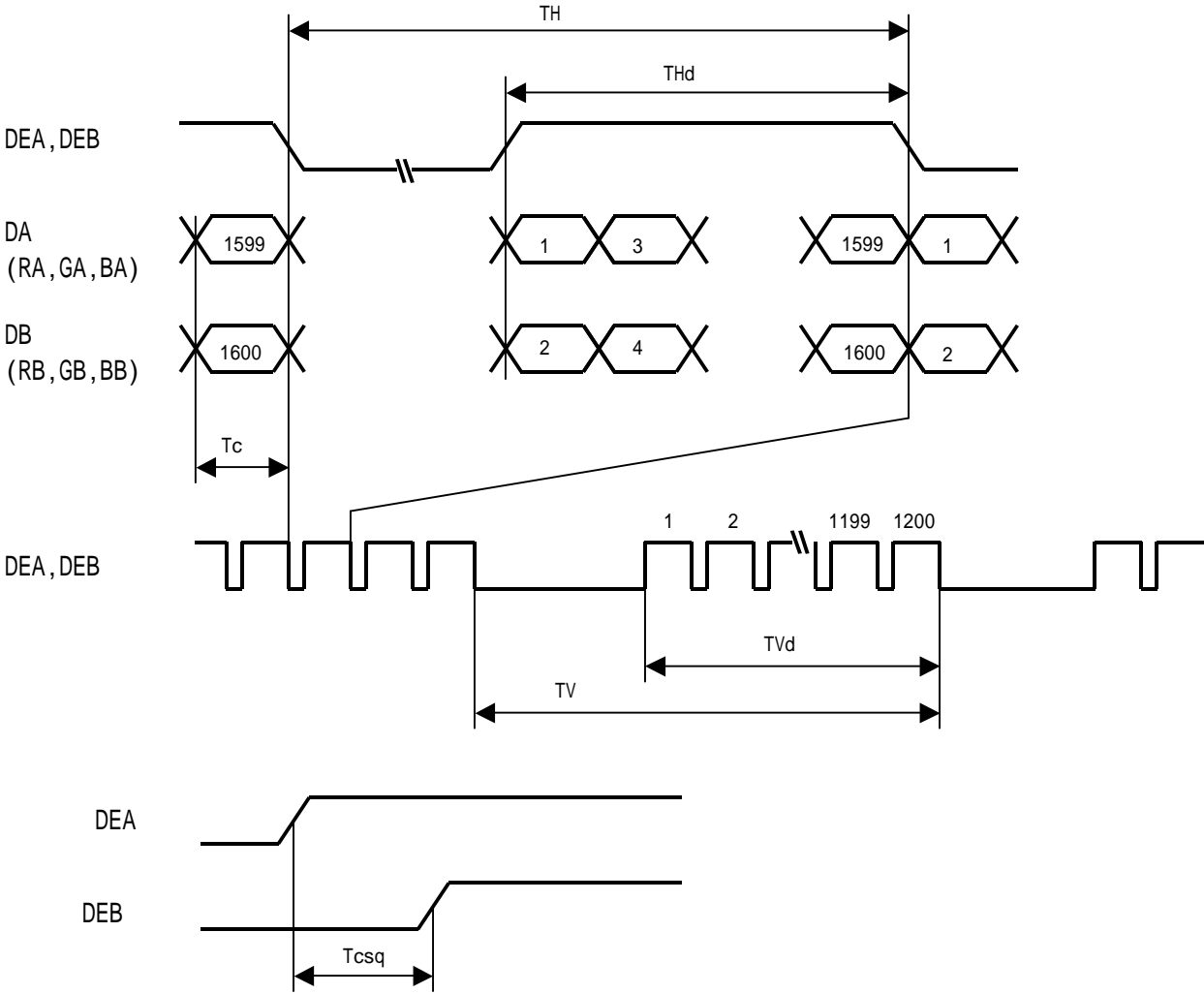

7-2 Input Data Signals and Display Position on the screen

Graphics and texts can be displayed on a 1600 × 3 × 1200 dots panel with 16M colors by supplying 48 bit data signal (8bit/color [256 gray scales] × 3 × 2 pixels).

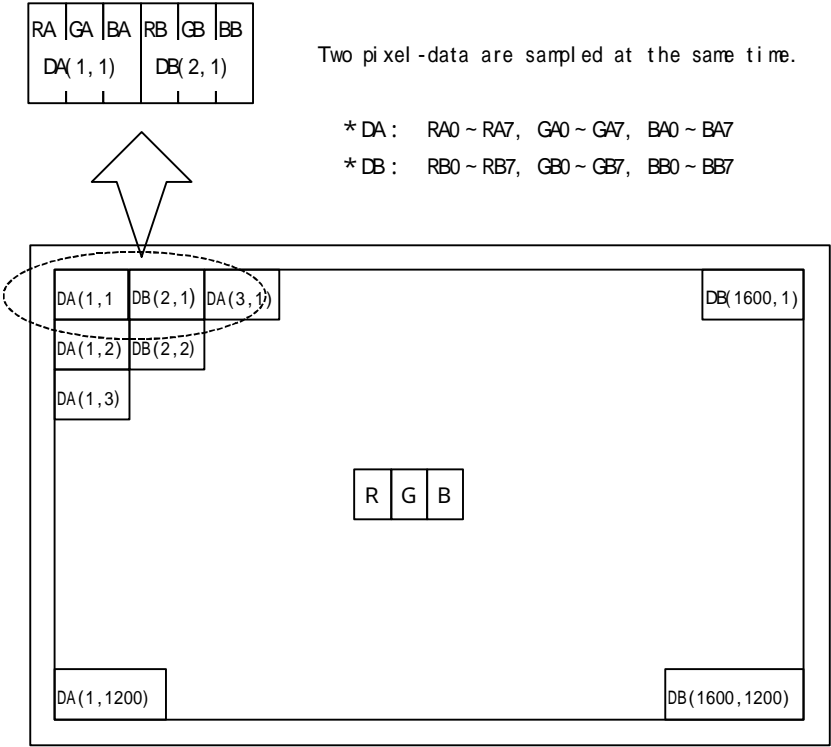

Display position of input data (H V)

8. Input Signals, Basic Display Colors and Gray Scale of Each Color

	Colors & Gray scale	Data signal																											
		Gray	RA0 RA1 RA2 RA3 RA4 RA5 RA6 RA7	GA0 GA1 GA2 GA3 GA4 GA5 GA6 GA7	BA0 BA1 BA2 BA3 BA4 BA5 BA6 BA7																								
		Scale	RB0 RB1 RB2 RB3 RB4 RB5 RB6 RB7	GB0 GB1 GB2 GB3 GB4 GB5 GB6 GB7	BB0 BB1 BB2 BB3 BB4 BB5 BB6 BB7																								
Basic Color	Black	-	0 0 0 0 0 0 0 0	0 0 0 0 0 0 0 0	0 0 0 0 0 0 0 0	0 0 0 0 0 0 0 0																							
	Blue	-	0 0 0 0 0 0 0 0	0 0 0 0 0 0 0 0	1 1 1 1 1 1 1 1	1 1 1 1 1 1 1 1																							
	Green	-	0 0 0 0 0 0 0 0	1 1 1 1 1 1 1 1	0 0 0 0 0 0 0 0	0 0 0 0 0 0 0 0																							
	Cyan	-	0 0 0 0 0 0 0 0	1 1 1 1 1 1 1 1	1 1 1 1 1 1 1 1	1 1 1 1 1 1 1 1																							
	Red	-	1 1 1 1 1 1 1 1	0 0 0 0 0 0 0 0	0 0 0 0 0 0 0 0	0 0 0 0 0 0 0 0																							
	Magenta	-	1 1 1 1 1 1 1 1	0 0 0 0 0 0 0 0	0 0 0 0 0 0 0 0	1 1 1 1 1 1 1 1																							
	Yellow	-	1 1 1 1 1 1 1 1	1 1 1 1 1 1 1 1	0 0 0 0 0 0 0 0	0 0 0 0 0 0 0 0																							
	White	-	1 1 1 1 1 1 1 1	1 1 1 1 1 1 1 1	1 1 1 1 1 1 1 1	1 1 1 1 1 1 1 1																							
Gray Scale of Red	Black	GS0	0 0 0 0 0 0 0 0	0 0 0 0 0 0 0 0	0 0 0 0 0 0 0 0	0 0 0 0 0 0 0 0																							
	↑	GS1	1 0 0 0 0 0 0 0	0 0 0 0 0 0 0 0	0 0 0 0 0 0 0 0	0 0 0 0 0 0 0 0																							
	Darker	GS2	0 1 0 0 0 0 0 0	0 0 0 0 0 0 0 0	0 0 0 0 0 0 0 0	0 0 0 0 0 0 0 0																							
	↑	↓		↓		↓		↓																					
	↓	↓		↓		↓		↓																					
	Brighter	GS253	1 0 1 1 1 1 1 1	0 0 0 0 0 0 0 0	0 0 0 0 0 0 0 0	0 0 0 0 0 0 0 0																							
	↓	GS254	0 1 1 1 1 1 1 1	0 0 0 0 0 0 0 0	0 0 0 0 0 0 0 0	0 0 0 0 0 0 0 0																							
	Red	GS255	1 1 1 1 1 1 1 1	0 0 0 0 0 0 0 0	0 0 0 0 0 0 0 0	0 0 0 0 0 0 0 0																							
Gray Scale of Green	Black	GS0	0 0 0 0 0 0 0 0	0 0 0 0 0 0 0 0	0 0 0 0 0 0 0 0	0 0 0 0 0 0 0 0																							
	↑	GS1	0 0 0 0 0 0 0 0	1 0 0 0 0 0 0 0	0 0 0 0 0 0 0 0	0 0 0 0 0 0 0 0																							
	Darker	GS2	0 0 0 0 0 0 0 0	0 1 0 0 0 0 0 0	0 0 0 0 0 0 0 0	0 0 0 0 0 0 0 0																							
	↑	↓		↓		↓		↓																					
	↓	↓		↓		↓		↓																					
	Brighter	GS253	0 0 0 0 0 0 0 0	1 0 1 1 1 1 1 1	0 0 0 0 0 0 0 0	0 0 0 0 0 0 0 0																							
	↓	GS254	0 0 0 0 0 0 0 0	0 1 1 1 1 1 1 1	0 0 0 0 0 0 0 0	0 0 0 0 0 0 0 0																							
	Green	GS255	0 0 0 0 0 0 0 0	1 1 1 1 1 1 1 1	0 0 0 0 0 0 0 0	0 0 0 0 0 0 0 0																							
Gray Scale of Blue	Black	GS0	0 0 0 0 0 0 0 0	0 0 0 0 0 0 0 0	0 0 0 0 0 0 0 0	0 0 0 0 0 0 0 0																							
	↑	GS1	0 0 0 0 0 0 0 0	0 0 0 0 0 0 0 0	1 0 0 0 0 0 0 0	0 0 0 0 0 0 0 0																							
	Darker	GS2	0 0 0 0 0 0 0 0	0 0 0 0 0 0 0 0	0 1 0 0 0 0 0 0	0 0 0 0 0 0 0 0																							
	↑	↓		↓		↓		↓																					
	↓	↓		↓		↓		↓																					
	Brighter	GS253	0 0 0 0 0 0 0 0	0 0 0 0 0 0 0 0	1 0 1 1 1 1 1 1	0 0 0 0 0 0 0 0																							
	↓	GS254	0 0 0 0 0 0 0 0	0 0 0 0 0 0 0 0	0 1 1 1 1 1 1 1	0 0 0 0 0 0 0 0																							
	Blue	GS255	0 0 0 0 0 0 0 0	0 0 0 0 0 0 0 0	1 1 1 1 1 1 1 1	0 0 0 0 0 0 0 0																							

0 : Low level voltage, 1 : High level voltage.

Each basic color can be displayed in 256 gray scales from 8 bit data signals. According to the combination of total 48 bit data signals, the 16-million-color display can be achieved on the screen.

9. Optical Characteristics

Ta=25 , Vcc =+12V

Parameter		Symbol	Condition	Min.	Typ.	Max.	Unit	Remark
Viewing Angle range	Vertical	11	CR 10	80	88	-	Deg.	【Note1,4】
		12		80	88	-	Deg.	
	Horizontal	21, 22		80	88	-	Deg.	
Contrast ratio		C R	=0 °	350	500	-		【Note2,4】
Response Time	Rise +Decay	r + d		-	20	55	ms	【Note3,4】
Chromaticity of white		Wx		0.283	0.313	0.343	-	【Note4】
		Wy		0.299	0.329	0.359	-	
Chromaticity of red		Rx		0.614	0.644	0.674	-	
		Ry		0.307	0.337	0.367	-	
Chromaticity of green		Gx		0.264	0.294	0.324	-	
		Gy		0.574	0.604	0.634	-	
Chromaticity of blue		Bx		0.114	0.144	0.174	-	
		By		0.063	0.093	0.123	-	
Luminance of white		YL		200	250	-	cd/m ²	IL=6.0mA rms FL=60kHz 【Note4】
White Uniformity		w		-	-	1.25	-	【Note5】

The measurement shall be executed 30 minutes after lighting at rating.

The optical characteristics shall be measured in a dark room or equivalent state with the method shown in Fig.2 below.

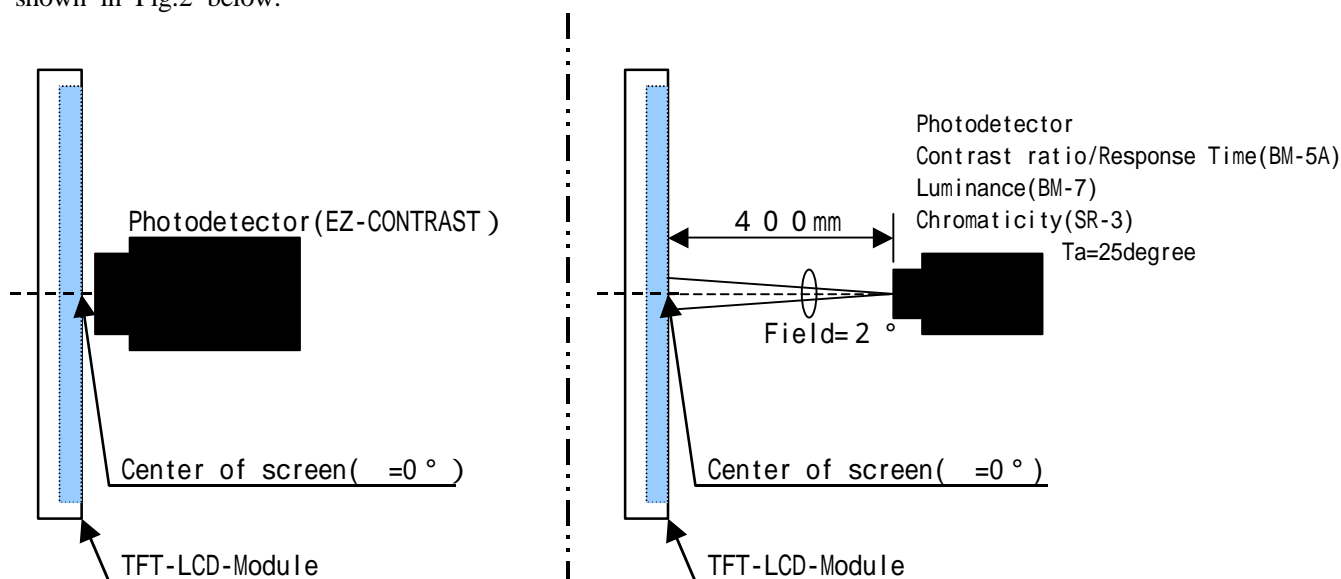
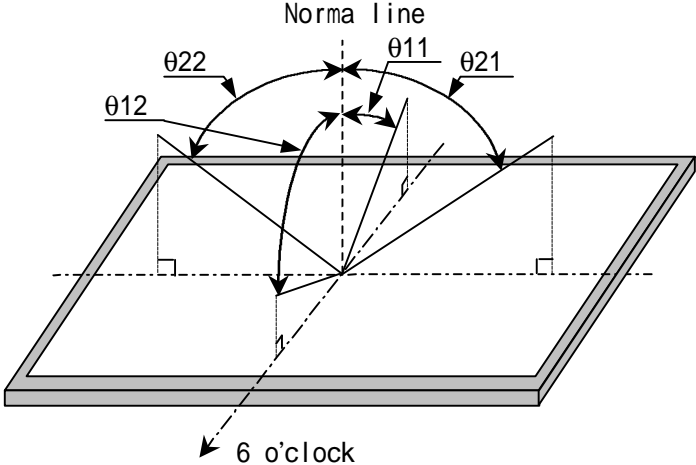

Fig2 Optical characteristics measurement method

【Note1】 Definitions of viewing angle range:



【Note2】 Definition of contrast ratio:

The contrast ratio is defined as the following.

$$\text{Contrast Ratio (CR)} = \frac{\text{Luminance (brightness) with all pixels white}}{\text{Luminance (brightness) with all pixels black}}$$

【Note3】 Definition of response time:

The response time is defined as the following figure and shall be measured by switching the input signal for "black" and "white".

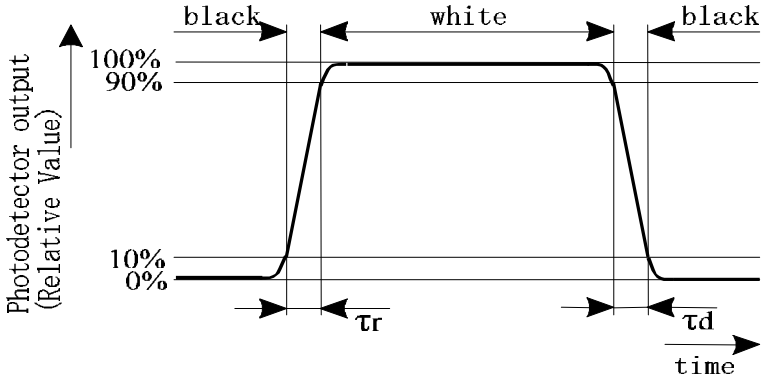

【Note4】 This shall be measured at center of the screen.

【Note5】 Definition of white uniformity:

White uniformity is defined as the following with nine measurements.

(A ~ I).

$$\ddot{a} w = \frac{\text{Maximum Luminance of nine points (brightness)}}{\text{Minimum Luminance of nine points (brightness)}}$$

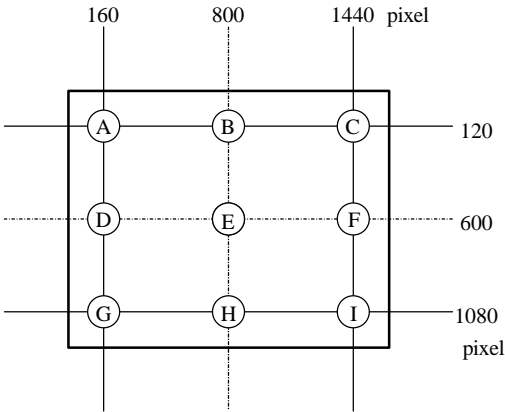

10. Handling Precautions

- a) Be sure to turn off the power supply when inserting or disconnecting the cable.
- b) Be sure to design the cabinet so that the module can be installed without any extra stress such as warp or twist.
- c) Since the front polarize is easily damaged, pay attention not to scratch it.
- d) Since long contact with water may cause discoloration or spots, wipe off water drop immediately.
- e) When the panel surface is soiled, wipe it with absorbent cotton or other soft cloth.
- f) Since the panel is made of glass, it may break or crack if dropped or bumped on hard surface. Handle with care.
- g) Since CMOS LSI is used in this module, take care of static electricity and take the human earth into consideration when handling.
- h) Make sure the mounting holes of the module are grounded sufficiently. Take electro-magnetic interference (EMI) into consideration.
- i) The module has some printed circuit boards (PCBs) on the back side. Take care to keep them from any stress or pressure when handling or installing the module; otherwise some of electronic parts on the PCBs may be damaged.
- j) Observe all other precautionary requirements in handling components.
- k) When some pressure is added onto the module from rear side constantly, it causes display non-uniformity issue, functional defect, etc. So, please avoid such design.
- l) If the stress is applied onto the panel under operating conditions, display defects such as black dots may occur. So, do not press the display with fingers.

To recover this defect, turn off the power supply and restart after several seconds.

11. Packing form

- a) Piling number of cartons : maximum 8 cartons
- b) Packing quantity in one carton : 2 modules
- c) Carton size : 583mm(W) × 478mm(H) × 215mm(D)
- d) Total mass of one carton filled with full modules : 8.9kg

14 . Carton storage condition

Temperature	0 to 40
Humidity	95%RH or less
Reference condition :	20 to 35 , 85%RH or less (summer) : 5 to 15 , 85%RH or less (winter) • the total storage time (40 ,95%RH) : 240H or less
Sunlight	Be sure to shelter a product from the direct sunlight.
Atmosphere	Harmful gas, such as acid and alkali which bites electronic components and/or wires, must not be detected.
Notes	Be sure to put cartons on palette or base, don't put it on floor, and store them with removing from wall. Please take care of ventilation in storehouse and around cartons, and control changing temperature is within limits of natural environment.
Storage period	1 year

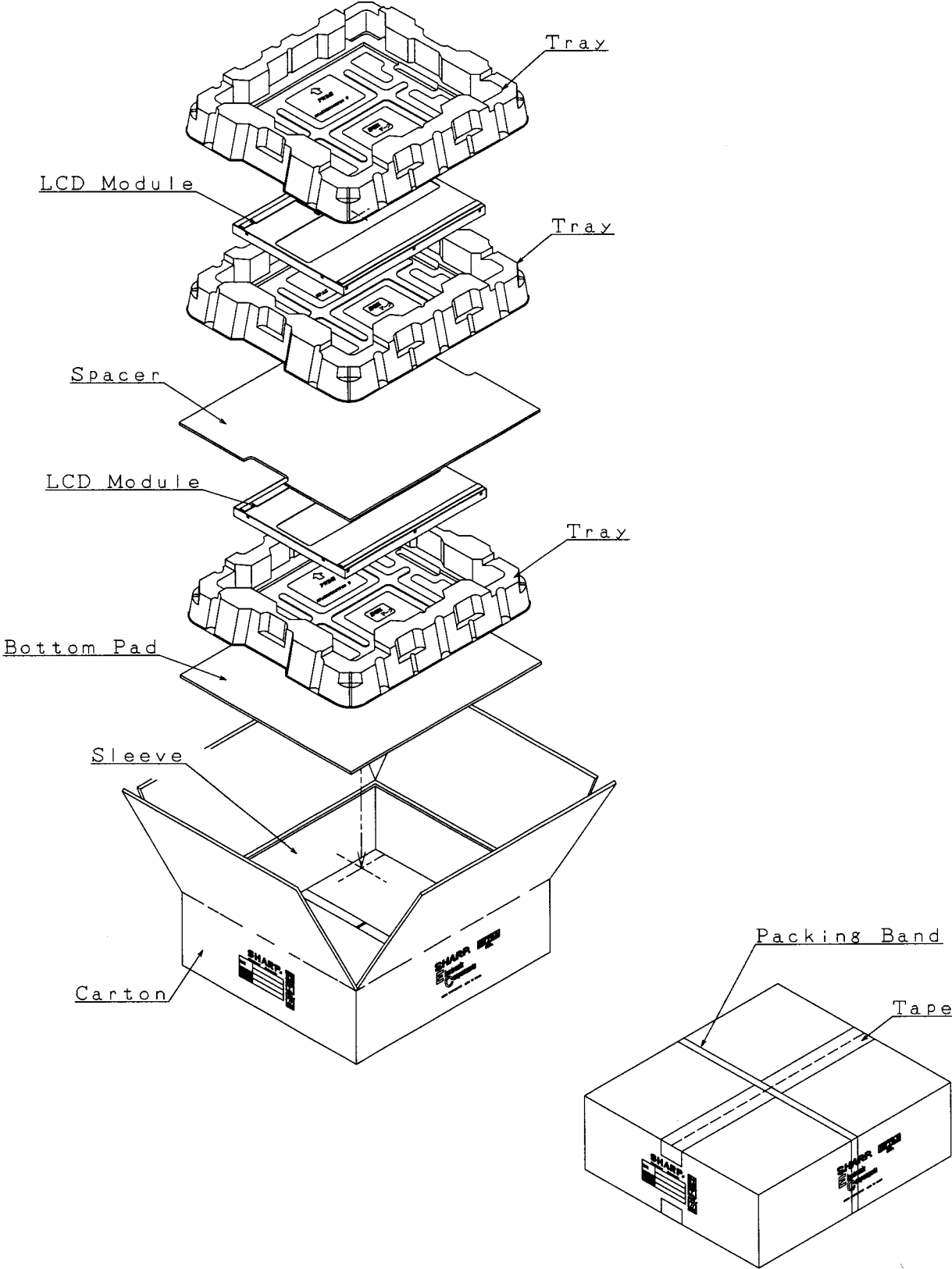

Packing Form

M3 P=0.5 INSERT NUT
(FOR USER USE)
TORQUE:
max 0.588 N·m
(max 6kgf·cm)

M3 P=0.5 INSERT NUT
(FOR USER USE)
TORQUE:
max 0.588 N·m
(max 6kgf·cm)

M3 P=0.5 INSERT NUT
(FOR USER USE)
TORQUE:
max 0.588 N·m
(max 6kgf·cm)

CCFT CONNECTOR
CN1/3: XHP-7 (JST)
PIN LAYOUT

1	High	PINK
2	NC	
3	NC	
4	High	BLUE
5	NC	
6	NC	
7	High	ORANGE

CCFT CONNECTOR
CN2/4: BHR-03VS-1 (JST)
PIN LAYOUT

1	Low	WHITE
2	Low	GRAY
3	Low	BROWN

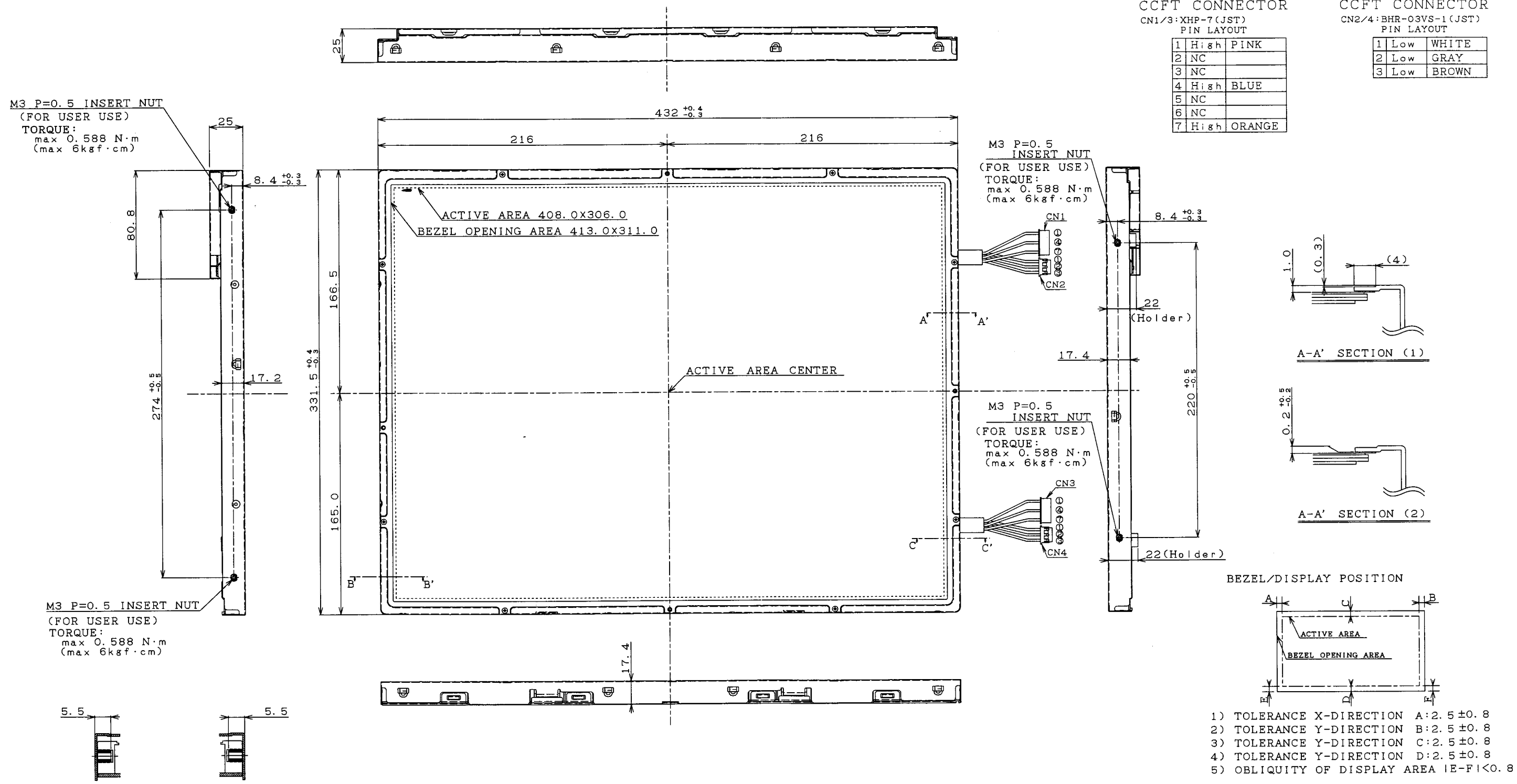

B-B' SECTION

C-C' SECTION

LQ201U1LW28 UXGA TFT MODULE OUTLINE DIMENSIONS

- BEZEL/DISPLAY POSITION
-
- 1) TOLERANCE X-DIRECTION A: 2.5 ± 0.8
 - 2) TOLERANCE Y-DIRECTION B: 2.5 ± 0.8
 - 3) TOLERANCE Y-DIRECTION C: 2.5 ± 0.8
 - 4) TOLERANCE Y-DIRECTION D: 2.5 ± 0.8
 - 5) OBLIQUITY OF DISPLAY AREA |E-F| < 0.8

*UNSPECIFIED TOLERANCE TO BE ± 0.5
UNIT: mm

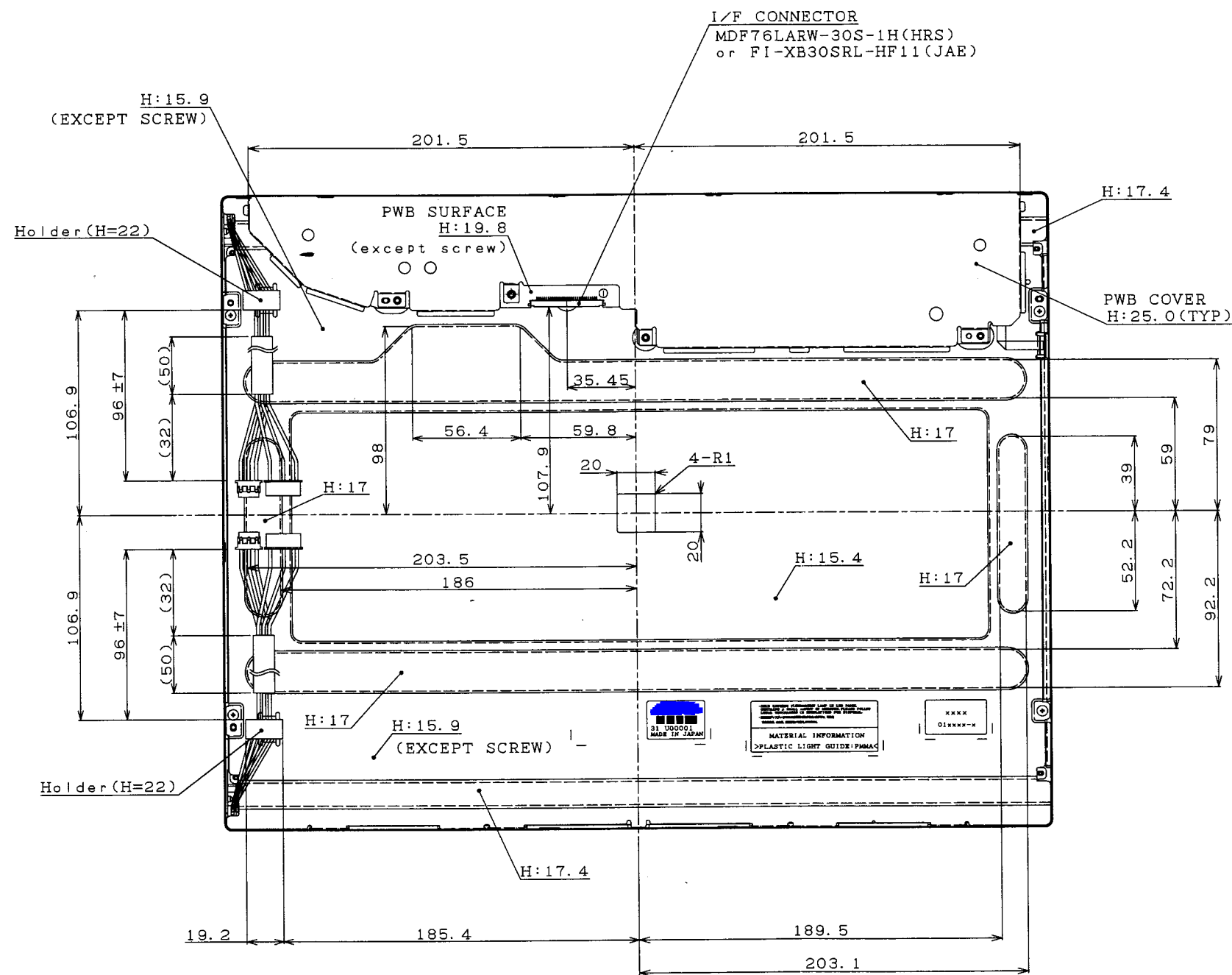

LQ201U1LW28 UXGA TFT MODULE OUTLINE DIMENSIONS